

С.Е. Калабина, В.О. Кулешова

MAGIC WORLD OF OPTICS

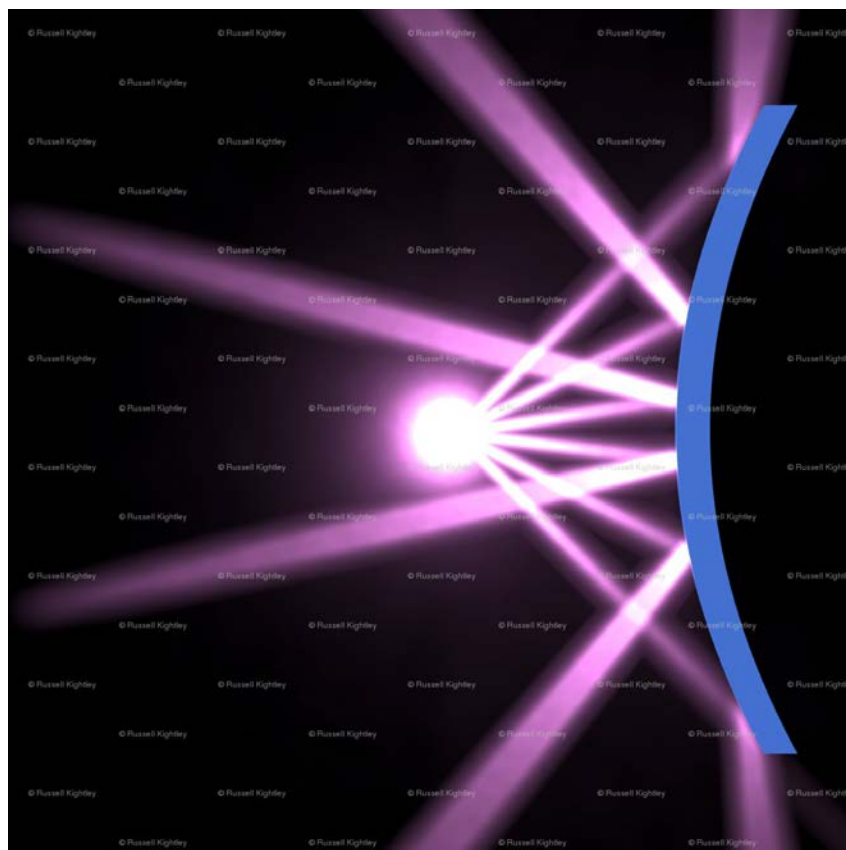

**Санкт-Петербург
2016**

МИНИСТЕРСТВО ОБРАЗОВАНИЯ И НАУКИ РОССИЙСКОЙ ФЕДЕРАЦИИ
УНИВЕРСИТЕТ ИТМО

С.Е. Калабина, В.О. Кулешова

MAGIC WORLD OF OPTICS

 **УНИВЕРСИТЕТ ИТМО**

Санкт-Петербург

2016

Калабина С.Е., Кулешова В.О. Magic world of optics, – СПб: Университет ИТМО, 2016. – 68 с.

Целью предлагаемого учебно-методического пособия является развитие навыков чтения и понимания оригинальных текстов, расширение словарного запаса у студентов по теме выбранной специальности, а так же развитие коммуникативных умений различных видов речевой деятельности. Пособие содержит справочный материал, обучающий составлению и оформлению презентаций, список математических символов и формул, а так же разговорные стратегии.

Учебно-методическое пособие построено на текстах из англоязычных учебников по оптике. К текстам добавлены упражнения, направленные на запоминание лексического материала и упражнения, направленные на развитие коммуникативных умений.

Учебно-методическое пособие по английскому языку «Magic world of optics» предназначено для студентов, обучающихся в магистратуре по специальностям 12.04.02 - оплотехника, 12.04.03 - фотоника и оптоинформатика.

Рекомендовано к печати Ученым советом ИМРиП 25 января 2016, протокол № 3.

Университет ИТМО – ведущий вуз России в области информационных и фотонных технологий, один из немногих российских вузов, получивших в 2009 году статус национального исследовательского университета. С 2013 года Университет ИТМО – участник программы повышения конкурентоспособности российских университетов среди ведущих мировых научно-образовательных центров, известной как проект «5 в 100». Цель Университета ИТМО – становление исследовательского университета мирового уровня, предпринимательского по типу, ориентированного на интернационализацию всех направлений деятельности.

© Университет ИТМО, 2016

© Калабина С.Е., Кулешова В.О., 2016

MAGIC WORLD OF OPTICS



Unit 1

Vision

1. Describing the structure of a human eye
2. Explaining how it works
3. Emphasising technical terms
4. Simplifying and illustrating technical explanations

Magic World of Optics

VISION

1. A. In pairs, discuss the following questions.

- What sciences deal with vision?
- How does a photocamera work?
- Compare an eye to a camera.
- Do you know any discoveries and breakthroughs inside optics?

1. B. Read the following article and compare it to your answers in Exercise 1a.

The human eye is a marvelous and intricate organ. If we leave the biological details to biologists and focus on the eye's optical properties, we find that it functions very much like a camera. Like a camera, the eye has refracting surfaces that focus incoming light rays, an adjustable iris to control the light intensity, and a light-sensitive detector.

Figure 1.1 shows the basic structure of the eye. It is roughly spherical, about 2.4 cm in diameter. The transparent **cornea**, which is somewhat more sharply curved, and the *lens* are the eye's refractive elements. The eye is filled with a clear, jellylike fluid called the *aqueous humor* (in front of the lens) and the *vitreous humor* (behind the lens. The indices of refraction of the aqueous and vitreous humors are 1.34, only slightly different from water).

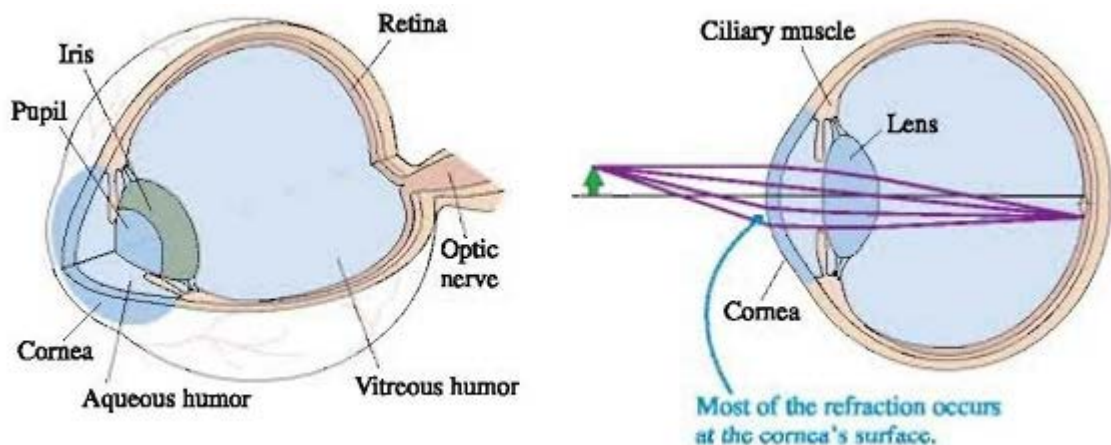

Figure 1.1 The human eye

The lens, although not uniform, has an average index of 1.44. The **pupil**, a variable-diameter aperture in the **iris**, automatically opens and closes to control the

light intensity. A fully dark-adapted eye can open to ≈ 8 mm, and the pupil closes down to ≈ 1.5 mm in bright sun. This corresponds to f -numbers from roughly $f/3$ to $f/16$, very similar to a camera.

The eye's detector, the **retina**, consists of specialized light-sensitive cells called *rods* and *cones*. The rods, sensitive mostly to light and dark, are most important in very dim lighting. Color vision, which requires somewhat more light, is due to the cones, of which there are three types. Figure 1.2 shows the wavelength responses of the cones. They have overlapping ranges, so two or even all three cones respond to light of any particular wavelength. The relative response of the different cones is interpreted by your brain as light of a particular color. Color is a *perception*, a response of our sensory and nervous systems, not something inherent in the light itself. Other animals, with slightly different retinal cells, can see ultraviolet or infrared wavelengths that we cannot see.

Focusing and Accommodation

The eye, like a camera, focuses light rays to an inverted image on the retina. Perhaps surprisingly, most of the refractive power of the eye is due to the cornea, not the lens. The cornea is a sharply curved, spherical surface, and as you know images are formed by refraction at a spherical surface. The rather large difference between the index of refraction of air and that of the aqueous humor causes a significant refraction of light rays at the cornea. In contrast, there is much less difference between the indices of the lens and its surrounding fluid, so refraction at the lens surfaces is weak. The lens is important for fine-tuning, but the air-cornea boundary is responsible for the majority of the refraction.

You can recognize the power of the cornea if you open your eyes underwater. Everything is very blurry! When light enters the cornea through water, rather than through air, there's almost no difference in the indices of refraction at the surface. Light rays pass through the cornea with almost no refraction, so what little focusing ability you have while underwater is due to the lens alone. But you can see perfectly well underwater while wearing a swim mask. Light passes through the flat plate of the mask without being bent, then enters your eye from the air rather than from the water.

The eye focuses by changing the focal length of the lens, a feat it accomplishes by using the *ciliary muscles* to change the curvature of the lens surface. The ciliary muscles are relaxed when you look at a distant scene. Thus the lens surface is relatively flat and the lens has its longest focal length. As you shift your gaze to a nearby object, the ciliary muscles contract and cause the lens to bulge. This process, called **accommodation**, decreases the lens's radius of curvature and thus decreases its focal length. Continuously looking at nearby objects can cause eye strain because the ciliary muscles are constantly in contraction.

The farthest distance at which a relaxed eye can focus is called the eye's **far point** (FP). The far point of a normal eye is infinity; that is, the eye can focus on

objects extremely far away. The closest distance at which an eye can focus, using maximum accommodation, is the eye's **near point** (NP). (Objects can be seen closer than the near point, but they're not sharply focused on the retina.) Both situations are shown in figure 1.3

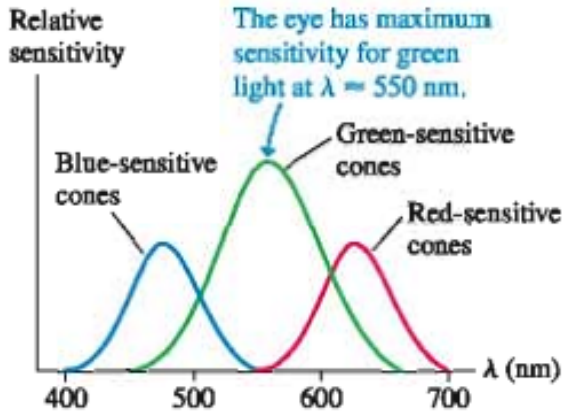

Figure 1.2 Wavelength sensitivity of the three types of cones in the human retina

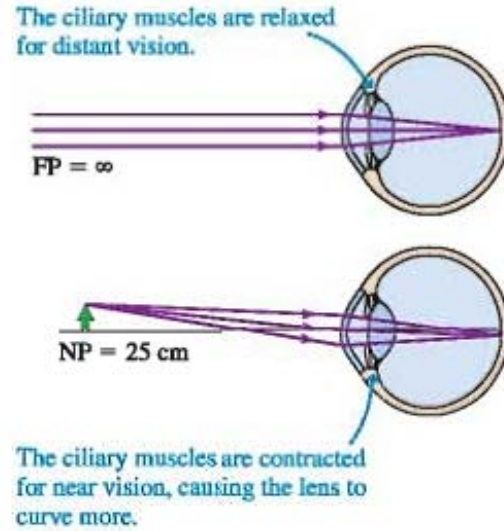

Figure 1.3 Normal vision of far and near objects

Randall D. Knight, PHYSICS for scientists and engineers A STRATEGIC APPROACH

2. A. New Vocabulary.

Match the terms to their definitions.

1. optical properties	a) An image in which up and down, as well as left and right, are interchanged; that is, an image that results from rotating the object 180° about a line from the object to the observer; such images are formed by most astronomical telescopes.
2. light ray	b) The property of an ellipse whereby rays of light emanating from one focus and reflected from a strip of polished metal at the ellipse come together at the other focus.
3. light intensity	c) A device that senses light. It uses the principle of photoconductivity, which is exhibited in certain materials that change their electrical conductivity when exposed to light.

4. refraction	d) the anterior transparent part of the outer tunic of the eye that is part of the eye's light-refracting apparatus and protects the eye from injury and dust.
5. iris	e) a column of light (as from a beacon).
6. light-sensitive detector	f) luminous intensity measured in candelas.
7. cornea	g) The diameter of the unobscured portion of the objective lens in a refracting telescope or of the primary mirror in a reflector.
8. index of refraction	h) perception by means of the eyes.
9. aperture	i) The pigmented, round, contractile membrane of the eye, suspended between the cornea and lens and perforated by the pupil. It regulates the amount of light entering the eye.
10. inverted image	j) The deflection of a wave, such as a light or sound wave, when it passes obliquely from one medium into another having a different index of refraction.
11. visual perception	k) a number indicating the speed of light in a given medium.

2.B. In pairs, practice explaining the terms in Exercise 2A.

2.C. Complete the following extract using the words in the box. You will need to use some words more than once.

Boundary, media, phenomenon, reflected ray, refraction, transmitted ray

The fundamental physical _____¹ at work in the eye is that when light crosses a _____² between two _____³, part of its energy is reflected, but part passes into the new medium. In the ray model of light, we describe the original ray as splitting into a _____⁴ and a transmitted one (the one that gets through the boundary). Of course the reflected ray goes in a direction that is different from that of the original one. More surprisingly - and this is the crucial point for making your eye focus light - the _____⁵ is bent somewhat as well. This bending phenomenon is called _____⁶. The origin of the word is the same as that of the word "fracture," i.e., the ray is bent or broken". _____⁷ occurs with all waves, not just light waves.

2.D. Complete the following text using the correct form of the verbs in the box.

Bent, enter, emerge, form, pass through, pass into, reach, refract

The actual anatomy of the eye, is quite complex, but in essence it is very much like every other optical device based on refraction. The rays are bent when they _____⁸ the front surface of the eye. Rays that _____⁹ farther from the central axis _____¹⁰ more, with the result that an image _____¹¹ on the retina. There is only one slightly novel aspect of the situation. In most human-built optical devices, such as a movie projector, the light is bent as it _____¹² a lens, bent again as it reemerges, and then _____¹³ a focus beyond the lens. In the eye, however, the "screen" is inside the eye, so the rays _____¹⁴ only _____¹⁴ once, on entering the jelly, and never _____¹⁵ again.

2.E. Complete the following table using the words in Exercises 2C and 2D.

Nouns	Verbs

2.F. Complete the following extract by underlining the correct word.

A _____¹ misconception is that the "lens" of the eye is what does the focusing. All the _____² parts of the eye are made of fairly similar stuff, so the dramatic change in _____³ is when a ray crosses from the air into the eye (at the outside surface of the cornea). This is where nearly all the _____⁴ takes place. The lens medium differs only slightly in its optical _____⁵ from the rest of the eye, so very little refraction _____⁶ as light enters and exits the lens. The lens, whose shape is _____⁷ by muscles attached to it, is only meant for fine-tuning the focus to form images of near or far objects.

1	a) general	b) common	c) big
2	a) transparent	b) transmission	c) clean
3	a) environment	b) matter	c) medium
4	a) refraction	b) refractivity	c) reflection
5	a) characteristics	b) features	c) properties
6	a) occurs	b) happens	c) arises
7	a) fixed	b) tuned	c) adjusted

3.A. Using New Vocabulary

You are going to give a talk on the structure of a human eye. In part of the talk, you focus on the parts of an eye. Prepare your talk using the text and the picture of an eye. Before preparing your talk, discuss the following terms and complete the picture below.

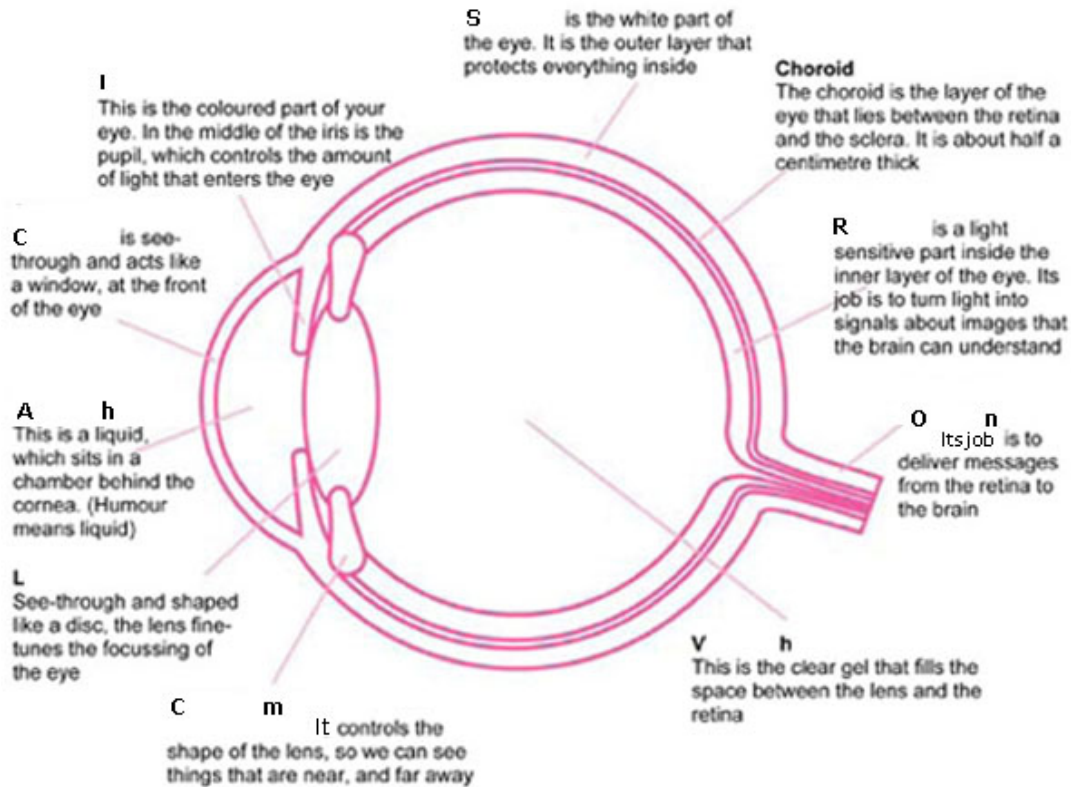

3.B. In small groups, take turns to give a talk.

4.A. Dialogue Work

Make up a dialogue of your own for one of the following situations (in pairs)
Situations:

1. **A.** Is a student who doesn't understand the structure of an eye. **B.** Is a teacher. **A.** Begins by asking for help
2. **A.** Meets his/her colleague **B.** at a library. **B.** Is preparing for his/her speech at BAKAMA's vision conference. They discuss the structure of the speech and conference's agenda.
3. **A.** Is a student making a presentation "vision". **B.** Is a teacher asking him questions

<p style="text-align: center;">Conversation Strategies Asking for help</p> <p>Could you . . . (for me) ? Would you please . . . ? Would you mind V+ing . . . ? Could you possibly . . . ? Okay, no problem. Sure, I'd be glad to. Sorry, I'm (kind of) busy now. I'm sorry. I don't have time right now. Do you have a minute? Can you spare a few minutes? Could you do me a favor? Could I ask you a favor? Can I ask you to . . . ? I need some help (if you have time). (If you're not busy) I could use your help</p>	
---	--

4.B. Questions for free conversation and discussion.

- 1) Show the rays path in a human eye.
- 2) Describe the following figures

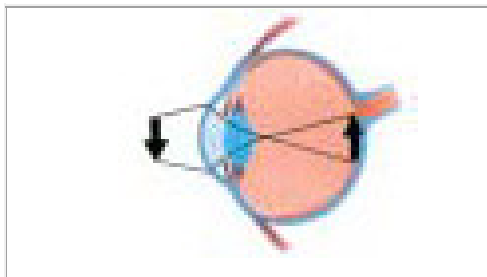
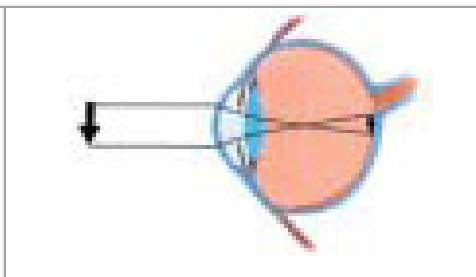
	
<p style="text-align: center;"><i>Focusing on a nearby object</i></p>	<p style="text-align: center;"><i>Focusing on a distant object</i></p>

MAGIC WORLD OF OPTICS

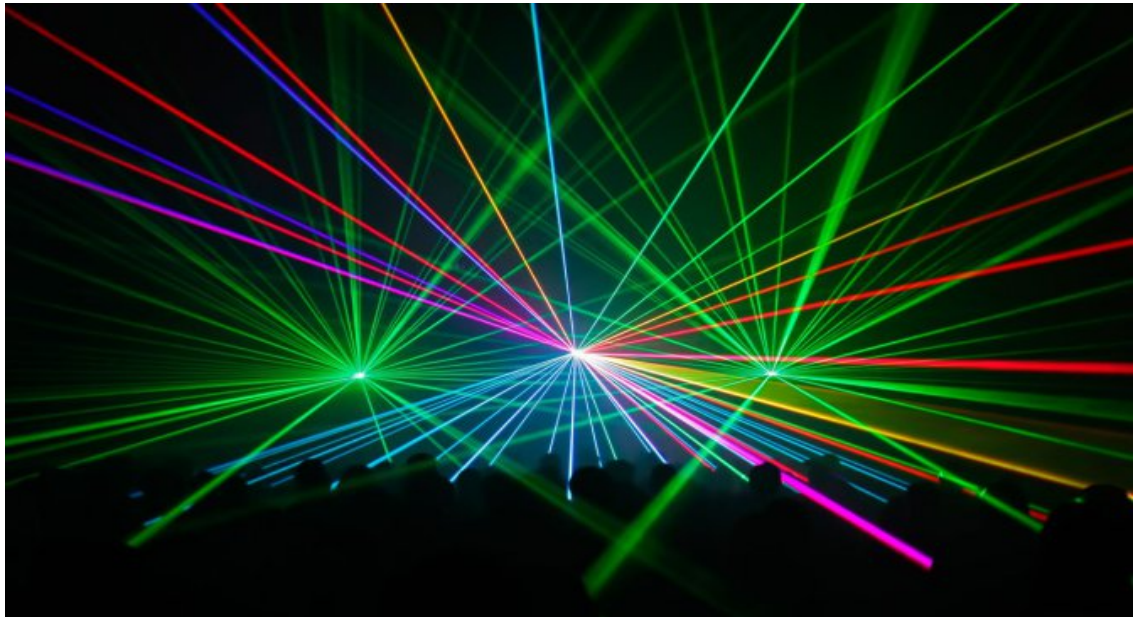

Unit 2

Models of Light

1. Describing the main models of light
2. Explaining circumstances where each model works
3. Interpreting technical terms
4. Discussing critical points

Magic World of Optics

MODELS OF LIGHT

1.A. In pairs, think about two or three models physics operates with and discuss the following questions.

- Why do physicists work with models?
- What basic physics models do you know?

1.B. Read the following article and answer the question: what types of models were described in the passage.

Light is a real physical entity, but the nature of light is elusive. Light is the chameleon of the physical world. Under some circumstances, light acts like particles traveling in straight lines. But change the circumstances, and light shows the same kinds of wave-like behavior as sound waves or water waves. Change the circumstances yet again, and light exhibits behavior that is neither wave-like nor particle-like but has characteristics of both.

Rather than an all-encompassing "theory of light", it will be better to develop several **models of light**. Each model successfully explains the behavior of light within a certain domain—that is, within a certain range of physical situations. We'll begin with a brief summary of all three models:

The wave model: The wave model of light is the most widely applicable model, responsible for the widely known "fact" that light is a wave. It is certainly true that, under many circumstances, light exhibits the same behavior as sound or water waves. Lasers and electro-optical devices, critical technologies of the 21st century, are best understood in terms of the wave model of light. The study of light as a wave is called **wave optics**.

The ray model: An equally well-known "fact" is that light travels in a straight line. These straight-line paths are called *light rays*. In Newton's view, light rays are the trajectories of particle-like corpuscles of light. The properties of prisms, mirrors, and lenses are best understood in terms of light rays. Unfortunately, it's difficult to reconcile the statement "light travels in a straight line" with the statement "light is a wave." For the most part, waves and rays are mutually exclusive models of light. The ray model of light is the basis of **ray optics or geometrical optics**.

The photon model: Modern technology is increasingly reliant on quantum physics. In the quantum world, light behaves like neither a wave nor a particle. Instead, light consists of *photons* that have both wave-like and particle-like properties.

The Wave and Ray Models of Light

There are three models of light, each useful within a certain range of circumstances. We should establish an important condition that separates the wave model of light from the ray model of light. When light passes through an opening of size a , the angle of the first diffraction minimum is

$$\theta_1 = \sin^{-1}\left(\frac{\lambda}{a}\right) \quad (2.1)$$

Equation 2.1 is for a slit, but the result is very nearly the same if a is the diameter of a circular aperture. Regardless of the shape of the opening, the factor that determines how much a wave spreads out behind an opening is the ratio λ/a , the size of the wavelength compared to the size of the opening.

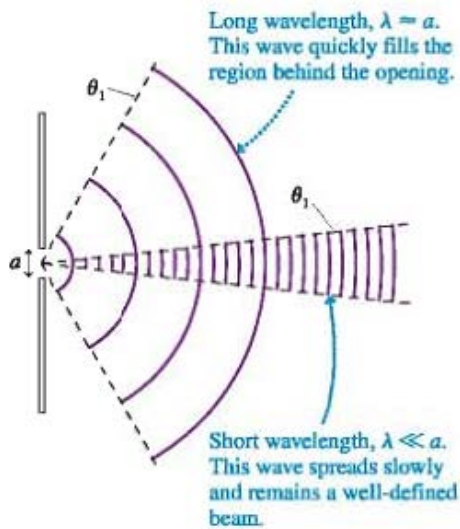

Figure 2.1 The diffraction of a long-wavelength wave and a short-wavelength wave

If light travels in straight lines, the image on the screen is the same size as the hole. Diffraction will not be noticed unless the light spreads over a diameter larger than D .

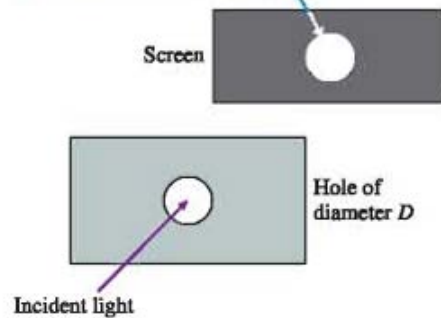

Figure 2.2 Diffraction will be noticed through the same opening only if the bright spot on the screen is wider than D

Figure 2.1 illustrates the difference between a wave whose wavelength is much smaller than the size of the opening and a second wave whose wavelength is comparable to the opening. A wave with $\lambda/a \approx 1$ quickly spreads to fill the region behind the opening. Light waves, because of their very short wavelength, almost always have $\lambda/a \ll 1$ and diffract to produce a slowly spreading "beam" of light.

Figure 2.2 shows light passing through a hole of diameter D . According to the ray model, light rays passing through the hole travel straight ahead to create a bright circular spot of diameter D on a viewing screen. This is the *geometric image* of the slit. In reality, diffraction causes the light to spread out behind the slit, but — and this is the important

point — we will not notice the spreading if it is less than the diameter D of the geometric image. That is, we will not be aware of diffraction unless the bright spot on the screen increases in diameter.

This idea provides a reasonable criterion for when to use ray optics and when to use wave optics:

- If the spreading due to diffraction is less than the size of the opening, use the ray model and think of light as traveling in straight lines.
- If the spreading due to diffraction is greater than the size of the opening, use the wave model of light.

The crossover point between these two regimes occurs when the spreading due to diffraction is equal to the size of the opening. The central-maximum width of a circular-aperture diffraction pattern is $w=2.44\lambda L/D$. If we equate this diffraction width to the diameter of the aperture itself, we have

$$\frac{2.44\lambda L}{D_c} = D_c \quad (2.2)$$

where the subscript c on D_c , indicates that this is the crossover between the ray model and the wave model. Solving for D_c , we find

$$D_c = \sqrt{2.44\lambda L} \quad (2.3)$$

This is the diameter of a circular aperture whose diffraction pattern, at distance L , has width $w = D$. We know that visible light has $\lambda \approx 500$ nm, and a typical distance in laboratory work is $L \approx 1$ m. For these values,

$$D_c \approx 1 \text{ mm} \quad (2.4)$$

This brings us to an important and very practical conclusion:

Choosing model of light

- When light passes through openings < 1 mm in size, diffraction effects are usually important. Use the wave model of light.
- When light passes through openings > 1 mm in size, diffraction effects are usually not important. Use the ray model of light

Openings ≈ 1 mm in size are a gray area. Whether one should use a ray model or a wave model will depend on the precise values of λ and L . Lenses and mirrors, in particular, are almost always > 1 mm in size.

2.A. New Vocabulary

Find the explanations of the following terms in the text.

Models of light, the wave model, wave optics, the ray model, geometrical optics, the photon model.

2.B. In pairs, practice explaining the terms in Exercise 2.A.

2.C. Complete the following extract using the words in the box. You will need to use some words more than once.

Aperture, diaphragm, divergence, effects, geometrical optics, lens rim, light ray, phenomenon

The direction in which a light beam propagates has been defined as a _____¹. A ray cannot be isolated due to the _____² of diffraction. By using a _____³, we can try to isolate a single light ray. This turns out to be impossible since when the _____⁴ approaches the light wavelength, the light beam _____⁵ increases. This effect is larger for smaller _____⁶. When an aperture or _____⁷ is large compared with the wavelength, the diffraction _____⁸ become less important and then we can approach the light ray concept with fair precision. The optics branch based on the concept of the light ray is known as _____⁹.

2.D. Complete the following text using the correct form of the verbs in the box.

V: be discernible, be seen, fill, expect, passing through, reduce, spread out

We can appreciate Newton's dilemma. With everyday-sized openings, sound and water waves have $\lambda/a = 1$ and diffract to _____¹ the space behind the opening. Consequently, this is what we come to _____² for the behavior of waves. Newton saw no evidence of this for light _____³ openings. We see now that light really _____⁴ behind an opening, but the very small λ/a ratio usually makes the diffraction pattern too small to see. Diffraction begins to _____⁵ only when the size of the opening is a fraction of a millimeter or less. If we wanted the diffracted light wave *to fill* the space behind the opening ($\theta_1 \approx 90^\circ$), as a sound wave does, we would need to _____⁶ the size of the opening to $a \approx 0.001$ mm! Although holes this small can be made today, with the processes used to make

integrated circuits, the light passing through such a small opening is too weak to _____⁷ by the eye.

2.E. Complete the following extract using the words in the box.

Visible, creation, diffraction, applicability, correspondence, comparable, observation

THE CORRESPONDENCE PRINCIPLE

The only reason we don't usually notice _____ of light in everyday life is that we don't normally deal with objects that are _____ in size to a wavelength of _____ light, which is about a millionth of a meter. Does this mean that wave optics contradicts ray optics, or that wave optics sometimes gives wrong results? No. Wave optics is a more general theory than ray optics, so in any case where ray optics is valid, the two theories will agree. This is an example of a general idea enunciated by the physicist Niels Bohr, called the _____ principle: when flaws in a physical theory lead to _____ of a new and more general theory, the new theory must still agree with the old theory within its more restricted area of _____. After all, a theory is only created as a way of describing experimental _____. If the original theory had not worked in any cases at all, it would never have become accepted.

2.F. Complete the following table using the words in Exercises 2.E.

What suffixes are used for nouns and for adjectives?

Nouns	Adjectives

Compare your answers with the pictures below. Try to deduce the rule.

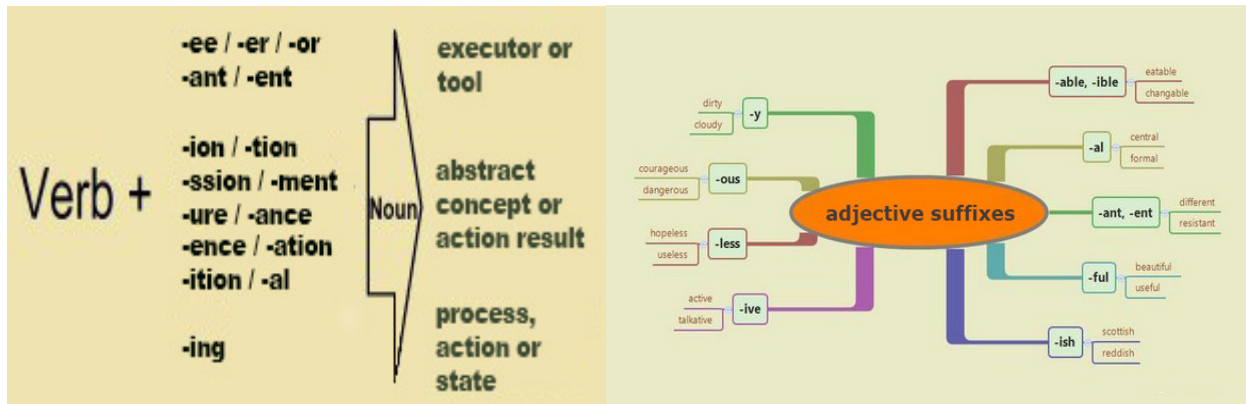

3.A. Using New Vocabulary

You are going to give a talk on the models of light. In part of the talk, you focus on these pictures. Prepare you talk using the text and the pictures. Try to answer the question: what models do pictures illustrate?

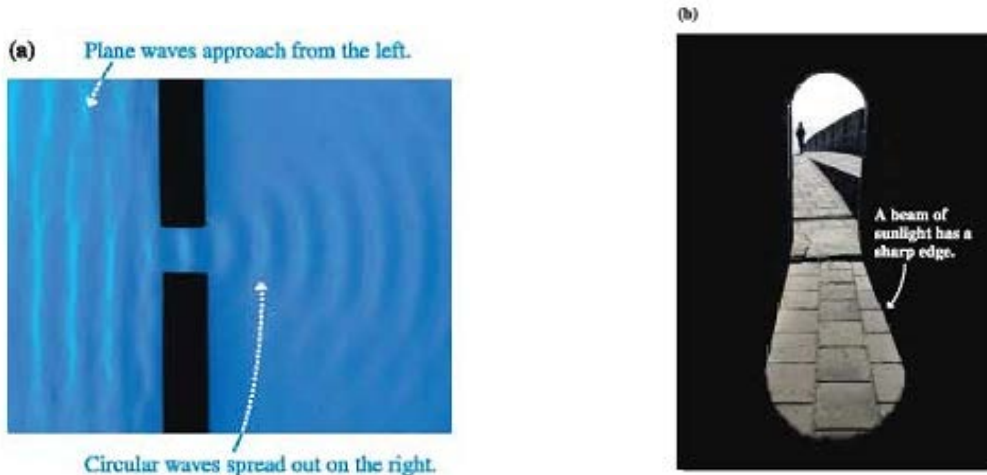

Figure 2.3 Water waves spread out behind a small hole in a barrier, but light passing through a doorway makes a sharp-edged shadow

3.B. In small groups, take turns to give a talk.

4.A. Dialogue Work

Make up a dialogue of your own for one of the following situations (in pairs)

Situations:

1. **A.** and **B.** are two group mates. They talk about the new seminar "Models of Light". **A.** starts with a question. **B.** asks to repeat.
2. **A.** meets his/her colleague **B.** at a library. **B.** is preparing for his/her speech at a conference. **A.** advises **B.** a book on the topic. **B.** asks to repeat.
3. **A.** is a student making a presentation "Models of Light". **B.** is his/her group mate. **B.** ask to repeat.

Asking for Repetition

- Here are some phrases and expressions asking for repetition or clarification in English.
- Excuse me?
- Could you repeat that?
- Could you say that again?
- What did you say?
- What was that (again)?
- Did you say . . . ?
- I'm sorry. I didn't catch that.

- What did you say your name was? **It's Cathy Henderson.**
- Did you say *Andersen* or *Henderson*? **Henderson, with an H.**
- Is "Cathy" spelled with a C or a K? **It's C as in Cadillac.**
- And what was your address again? **72 West Sunshine Blvd., Suite 501.**
- Sorry, I didn't catch the last part. **Do you want me to repeat it?**
- I can't hear you very well. **Maybe you should turn down the radio?**



<http://anna-english-teacher.webs.com/>



4.B. Questions for free conversation and discussion.

- 1) Why was the light called chameleon?
- 2) Tell about the wave model and when we should choose it.
- 3) Tell about the ray model and when we should choose it.
- 4) Tell about the photon model and when we should choose it.
- 5) What principles should we base of to choose the model?
- 6) Explain why opening diameter ≈ 1 mm is critical point.
- 7) If you hold three fingers out in the sunlight and cast a shadow with them, what theory can be used to predict the straightforward result? Why?

MAGIC WORLD OF OPTICS

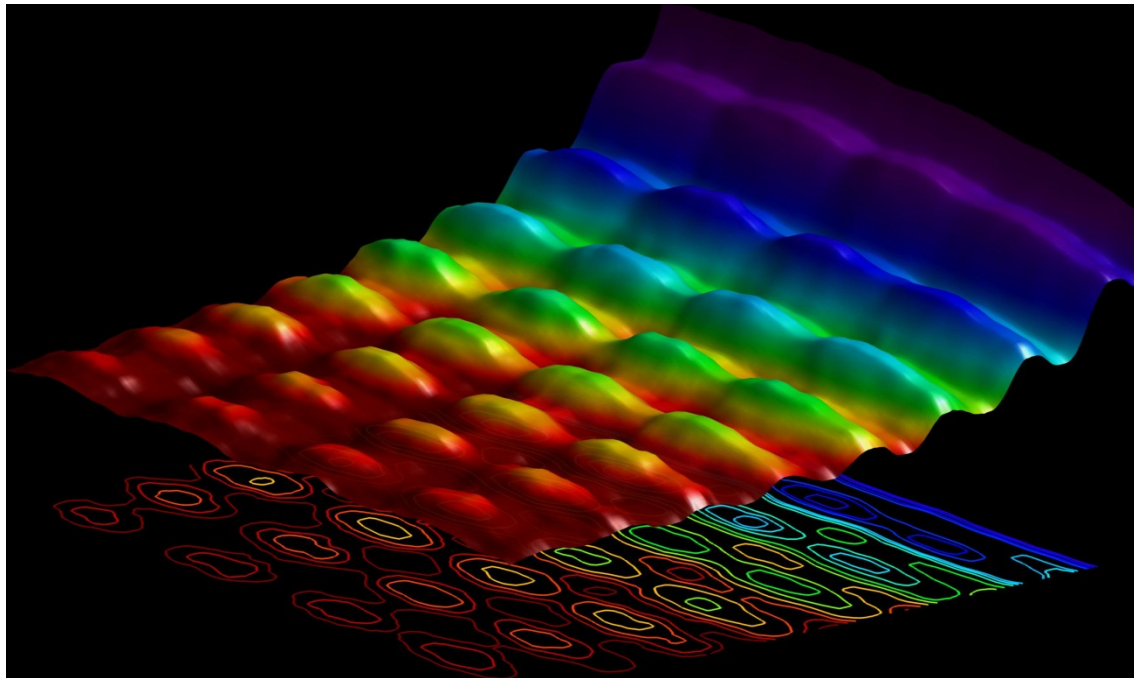

Unit 3

WAVE NATURE OF LIGHT

1. Explaining the nature of light
2. Describing polarization states
3. Interpreting new terms
4. Discussing technical innovations

Magic World of Optics

WAVE NATURE OF LIGHT

1.A. in pairs, think about two or three products based on waves work and discuss the following questions.

- What types of waves do they produce?
- How do they work?
- What kind of waves can be generated and/or perceived by a human being?

1.B. Read the following article and answer the question: what is the nature of light?

The nature of light is one of the most difficult concepts in modern physics. Due to its quantum nature, light has to be considered in some experiments as an electromagnetic wave, and in some others it has to be considered as a particle. However, in ordinary optical instruments we may just think of the light as an electromagnetic wave with an electric field and a magnetic field, mutually perpendicular, and both perpendicular to the path of propagation. If the light beam is plane (linearly) polarized, the electric and the magnetic fields have a constant fixed orientation, changing only in magnitude and sign as the wave propagates. The electric and magnetic fields are in phase with each other, as shown in Figure 3.1.

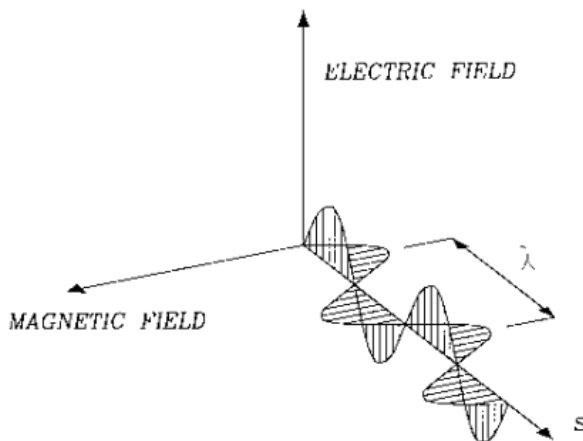

Figure 3.1 Electric and magnetic fields in an electromagnetic wave

This is the simplest type of wave, but we may find more complicated light beams, where the electric and magnetic fields do not oscillate in a fixed plane. The different manners in which the fields change direction along the light trajectory are called

polarization states. It is shown in any physical optics textbook that any polarization state may be considered as a superposition of two mutually perpendicular plane-polarized light beams. The type of polarization depends on the phase difference between the two components and on their relative amplitudes as explained in any physical optics textbook. The frequency ν and the wavelength λ of this wave are related by the speed of propagation v as follows:

$$\lambda \nu = v \quad (3.1)$$

Light waves with different frequencies have different colors, corresponding to certain wave lengths s in the vacuum.

Along the path of propagation of a light beam, the magnitude E of the electric field may be written as

$$E = A \exp i(ks - \omega t) = A \exp i(\phi - \omega t) \quad (3.2)$$

where A is the amplitude of the wave, k is the wave number, defined by $k = 2\pi/\lambda$, and ω is the angular frequency, defined by $\omega = 2\pi\nu$.

The wavelength is represented by λ and the frequency by ν . In this expression, s is the distance traveled along the light path, ϕ is the phase difference between the point being considered and the origin, and $\phi = \omega t$ is the instantaneous phase, assuming that it is zero at the origin for $t = 0$. A wavefront in a light beam is a surface in space for which all points have the same instantaneous phase ϕ . Another equivalent definition given by Kidger (2001) is that a wave front is a surface of constant optical path length, along the light path from a luminous point in the object. So, we may imagine on a light wave a family of surfaces in which the disturbance becomes a maximum at a certain time; i.e., the crests for the light waves. These surfaces are wave fronts and the distance between two consecutive wavefronts is the wavelength as illustrated in Figure 3.2.

The speed of light in a vacuum is about 300,000 km/sec and it is represented by c . In any other transparent medium, the speed v is less than c (except in extremely rare conditions known as anomalous dispersion). The refractive index n for a material is defined as

$$n = \frac{c}{v} \quad (3.3)$$

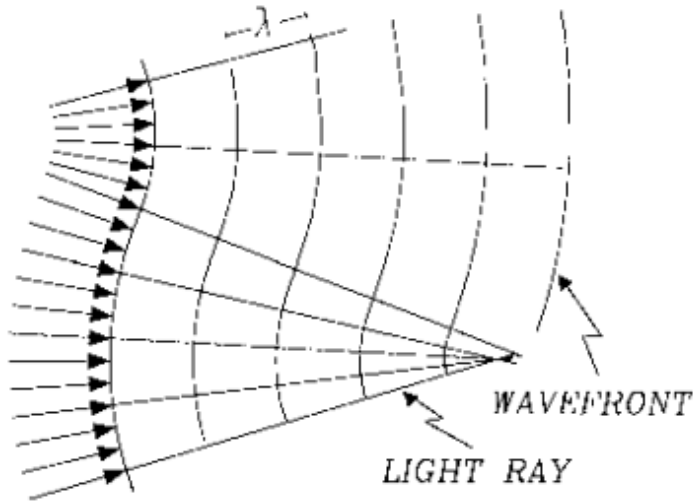

Figure 3.2 Light rays and wavefronts in an isotropic medium

For a given material, the refractive index n is a function of the light color (wavelength in the vacuum). As a general rule, this index decreases with increasing wavelength, as shown in Figure 3.3 for two typical glasses. The index of refraction increases with the wavelength only in certain small spectral regions outside of the visible spectrum.

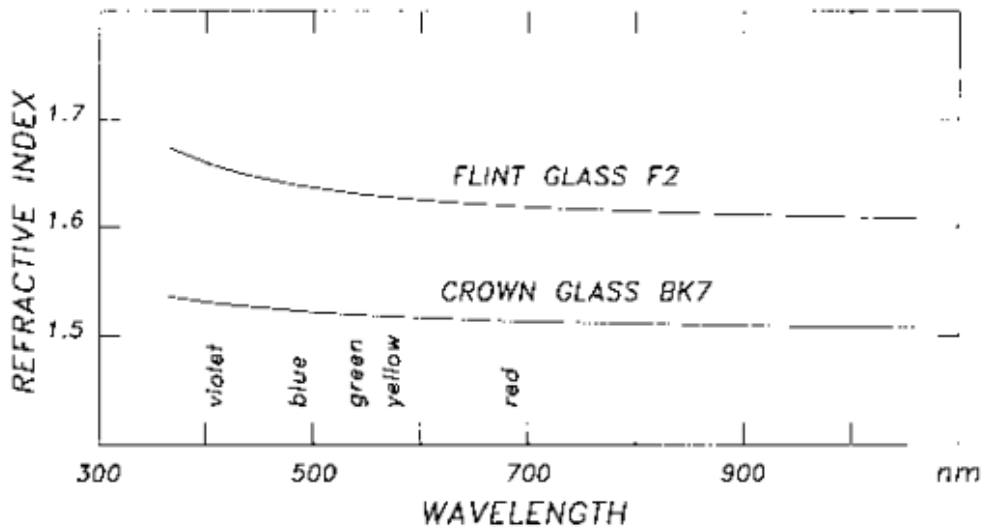

Figure 3.3 Refractive indices of a crown and a flint glass as a function of the wavelength

Using the definition for refractive index, the time t for light to go from a point P_1 to another point P_2 in an isotropic, homogeneous, or inhomogeneous medium is given by

$$t = \frac{1}{c} \int_{P_1}^{P_2} n \, ds \quad (3.4)$$

where $ds^2 = dx^2 + dy^2 + dz^2$. It is convenient to define the optical path OP as

$$OP = \int_{P_1}^{P_2} n \, ds \quad (3.5)$$

An optically transparent medium is said to be homogeneous and isotropic if the light travels at the same speed in every direction inside the medium, independently of the orientation of the electric field (polarization), as shown in Figure 3.4(a). A transparent medium is anisotropic (like in crystals) if the traveling velocity of the light is different for different orientations of the electric field (polarization state) of the wave, even if the traveling direction is the same, Figure 3.4(b). Many crystals, like quartz or calcite, are anisotropic. In these materials, even if they are homogeneous (same refractive index for all points in the medium), depending on the polarization orientation, either a spherical or ellipsoidal wave front is produced with a point light source. The medium is isotropic and inhomogeneous if the light speed depends on the direction of propagation, but not on the orientation of the electric field, Figure 3.4(c).

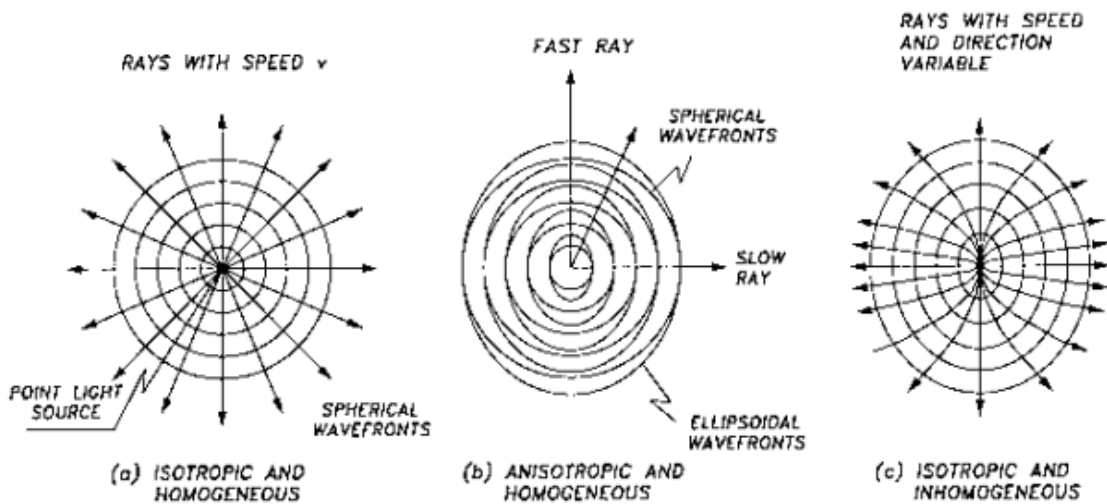

Figure 3.4 Wavefronts in different types of media: (a) isotropic and homogeneous; (b) anisotropic and homogeneous; (c) isotropic and inhomogeneous

2.A. New Vocabulary.

Match the terms to their definitions

1. Wavefront	a) The graph of the oscillating variations making up a wave, relative to time.
2. Wave number	b) An undulation or vibration; a form of movement by which all radiant energy of the electromagnetic spectrum is estimated to travel.
3. Wave	c) In considering a field of electromagnetic energy emanating from a source, it is a surface connecting all field points that are equidistant from the source.
4. Wavelength	d) It is the physical distance covered by one cycle of the wave; it is inversely proportional to frequency.
5. Waveform	e) The frequency of a wave divided by its velocity of propagation; the reciprocal of the wavelength.
6. Wavelet	f) It is a wave-like oscillation with an amplitude that starts out at zero, increases, and then decreases back to zero.

2.B. In pairs, practice explaining the terms in Exercise 2A.

2.C. Complete the following extract using the words in the box. You will need to use some words more than once.

N: Deformation, disturbance, initial position, matter, mixture, surface, wave

A TRAVELING DISTURBANCE

What is a wave? A wave is a traveling disturbance without any transport of _____¹. For example, when you snap a jump rope, a pattern of _____² passes from one end of the rope to the other, but the parts of the rope stay put. You can start a _____³ of falling upright dominoes in a long line by striking the end domino so that it topples against its neighbor, which then falls and strikes its neighbor, and so on. The _____⁴—falling dominoes—propagates from one end of the line to the other, yet no domino moves far from its _____⁵. Light waves are somewhat more abstract. For one thing, they can travel in a vacuum: They do not need a “medium” such as air or rope or dominoes or a water

_____ ⁶. For another, the disturbance is in the form of a _____ ⁷ of changing electric and magnetic fields.

2.D. Complete the following extract using the correct form of the verbs in the box. You will need to use some words more than once.

V: be proportional, carry, compress, effect, stretch, transport, travel, turns out, work

Nevertheless, it _____ ¹ that the description of wave properties that _____ ² well for sound waves in air or deformations traveling through solid, _____ ³ equally well for light.

Although waves do not themselves _____ ⁴ matter, they _____ ⁵ momentum and energy from one point in space to another. It is by means of such transported momentum and energy that waves can _____ ⁶. The warmth of sunshine tells you that light waves _____ ⁷ energy. The pain in your ears tells you that rock music _____ ⁸ momentum. The specific definition of “intensity” of a wave in three dimensions is the amount of energy carried across a unit area in a unit time.

It is important to know that the energy carried by any wave _____ ⁹ to the square of its amplitude. Sound waves and waves along strings all _____ ¹⁰ and _____ ¹¹ the matter through which they _____ ¹² just the way a spring can be stretched and compressed. It is not obvious that this rule should work for water waves and light waves, but it does.

2.E. Complete the following extract by underlining the correct word.

TRANSVERSE AND LONGITUDINAL WAVES

Waves are also _____ ¹ by the direction of the _____ ² of the wave relative to its direction of _____ ³. If a wave is _____ ⁴ a taut string, and each element of the string moves up and down vertically as the wave moves in the _____ ⁵x-direction. When the displacement _____ ⁶ with a wave is perpendicular to the direction of propagation the wave is said to be a “*transverse*” wave. If the displacement is parallel to the direction of propagation the wave is said to be a “*longitudinal*” wave. _____ ⁷ waves in air are longitudinal waves; light waves in a vacuum are transverse waves.

1	a) characterized	b) described	c) defined
2	a) shift	b) displacement	c) movement
3	a) distribution	b) propagation	c) spreading
4	a) moving forward	b) going along	c) traveling on
5	a) right	b) positive	c) plus
6	a) connected	b) linked	c) associated
7	a) sound	b) acoustic	c) sonic

3.A. Using New Vocabulary

You are going to give a talk on wavefronts. Prepare your talk using the text and the picture below. Before preparing your talk, look at the terms in 2.A.

3.B. In small groups, take turns to give a talk.

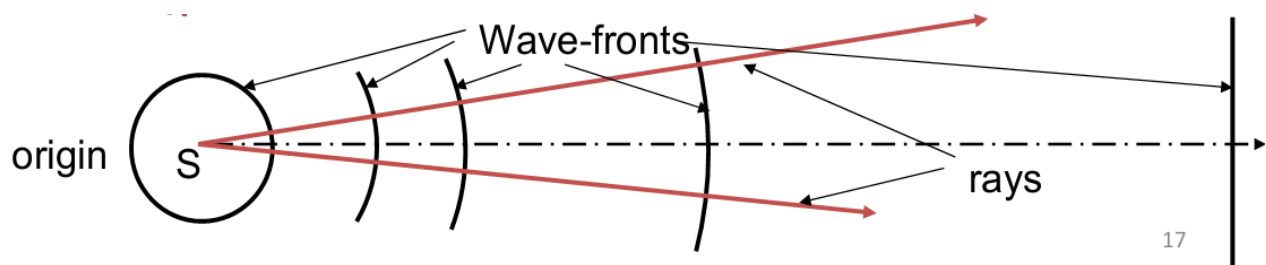

4. A. Dialogue Work

Make up a dialogue of your own for one of the following situations (in pairs)
Situations:

1. **A.** and **B.** are two friends. **A.** asks about a monograph **B.** is reading now. **A.** starts with a question. **B.** gives a short answer. **A.** asks follow-up questions.
2. **A.** wants to read a book about wave nature of light but does not know what to choose. She/he asks her/his friend **B.** (who reads a lot) what he/she can recommend.
3. **A.** says how good the ITMO University library is. **B.** (a student of Politech University) asks follow-up questions to know why **A.** likes it so much.

**NOBODY IS
EVER “JUST
WONDERING”.
THERE’S
ALWAYS A
REASON WHY
THEY ASKED.**

Spoken English:

We often use follow-up questions when we are listening, to show that we are interested or surprised. They often do not need a response. They are like response tokens such as *really*, *okay*, *yeah*. Follow-up questions are sometimes called reply questions.

Follow-up questions are formed using the auxiliary verb or modal verb contained in the statement that the question is responding to. If there is no auxiliary verb or modal verb in the statement, we use *do* in the present and *did* in the past (the verbs in the statements are underlined):

A:

I left school when I was 14.

B:

Did you? Really?

A:

It was in the 1950s. Many kids left school early then.

A:

Carla's decided to move to Spain.

B:

Has she? Good for her.

A:

I can't watch horror movies.

B:

Can't you?

A:

I just can't. They frighten me too much.

4.B. Questions for free conversation and discussion.

- 1) What parameters do we use to characterize waves?
- 2) What do you know about refractive index?
- 3) Explain the picture

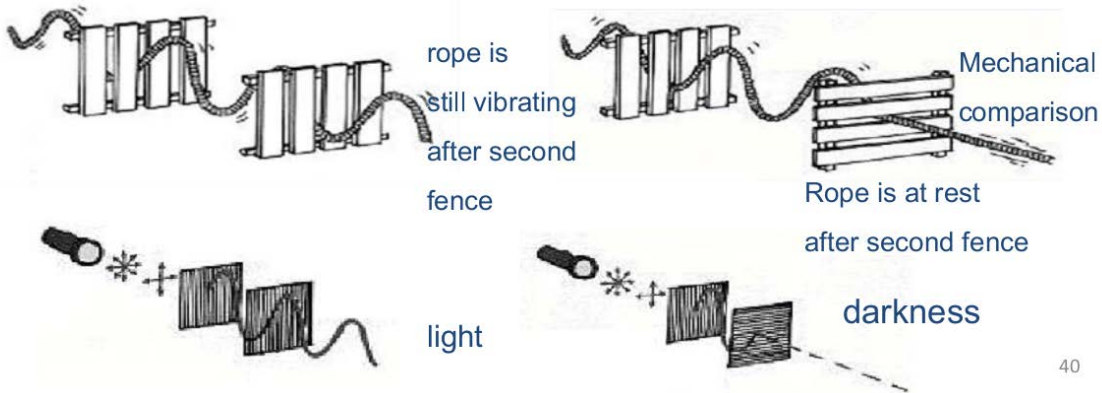

- 4) Tell about difference and similarity of sound and light waves.
- 5) Tell about optical properties of medium
- 6) Describe the electromagnetic spectrum. Use the picture to help you.

THE ELECTROMAGNETIC SPECTRUM

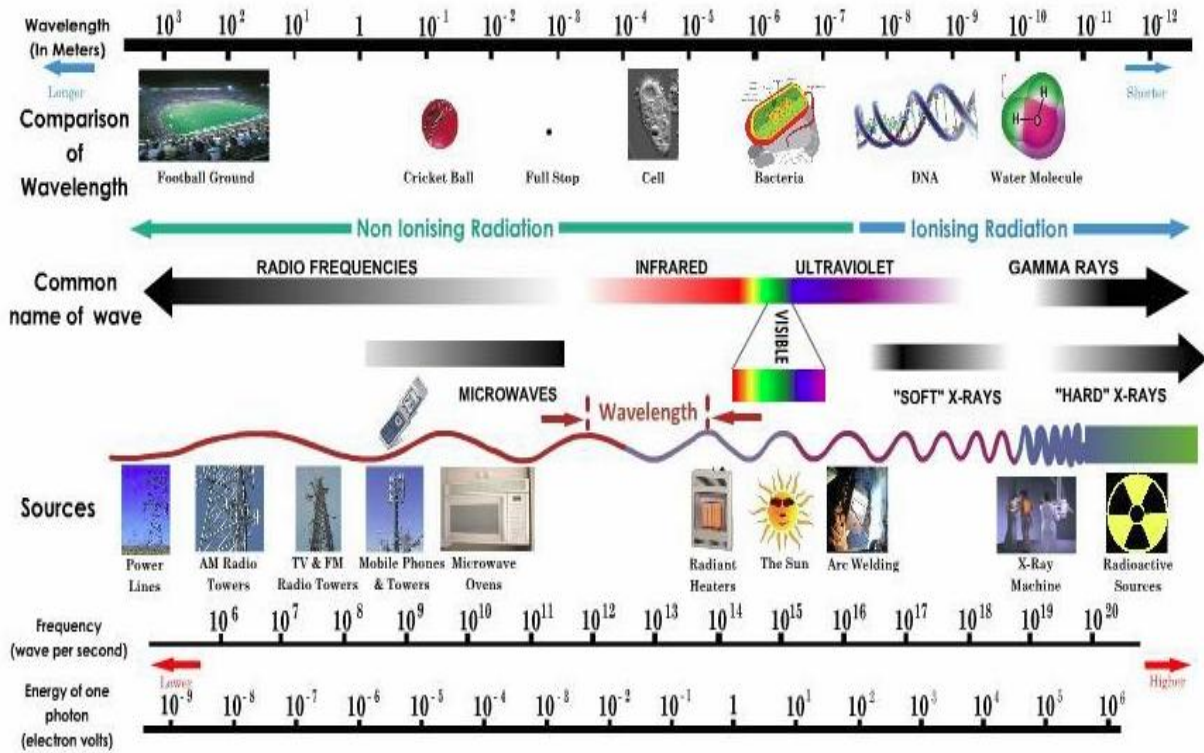

MAGIC WORLD OF OPTICS

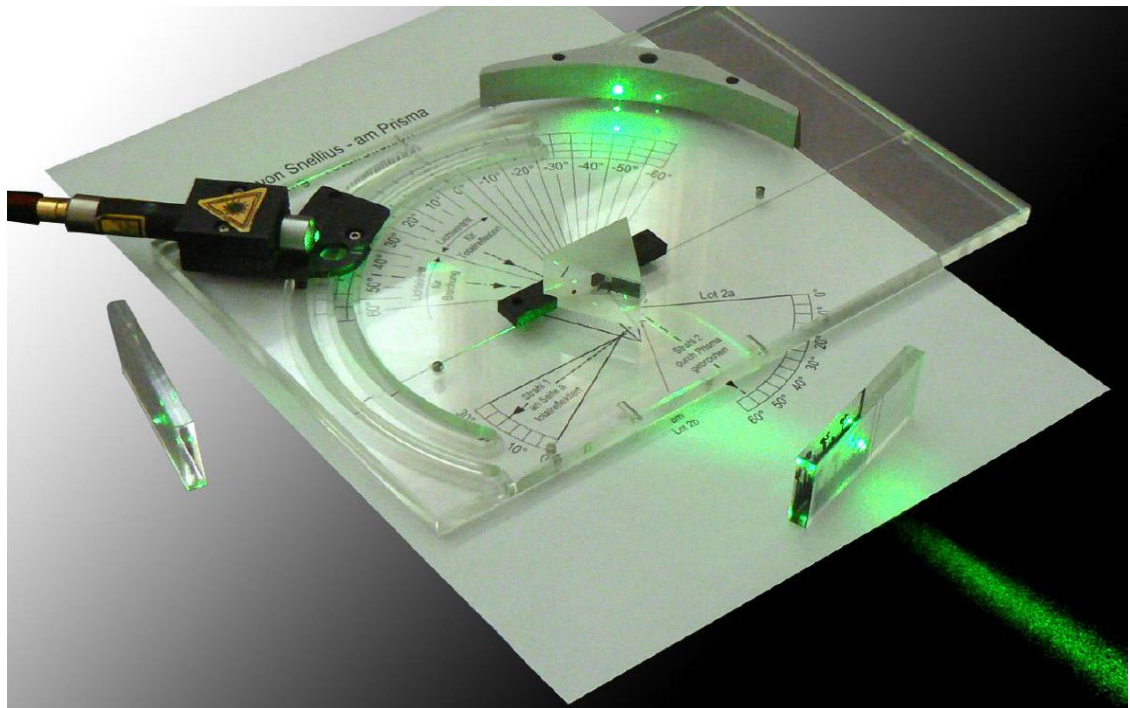

Unit 4

LAWS OF GEOMETRICAL OPTICS

1. Explaining laws of geometrical optics
2. Describing how they work
3. Emphasising technical terms
4. Simplifying and illustrating technical explanations

Magic World of Optics

LAWS OF GEOMETRICAL OPTICS

1.A. In pairs, discuss the following questions.

- What is Law for Physics?
- What are the main Physics Laws?
- What laws of geometrical optics do you know?

1.B. Read the following article and compare it to your answers in Exercise 1.A

LAWS OF GEOMETRICAL OPTICS

Malus law equation for the $OP = \int_{P_1}^{P_2} n ds$ optical path may also be written in differential form as

$$\frac{dOP}{ds} = n \quad (4.1)$$

where the OP is measured along any geometrical path ds . We define the eikonal φ as the optical path along trajectories always perpendicular to the wave fronts, related to the phase ϕ by

$$\varphi = \phi/k$$

The Malus law, as illustrated in Figure 4.1, states that in an isotropic medium, light rays are always perpendicular to the wave front. We may mathematically state this law by means of the eikonal equation, which may be written as

$$|\nabla\varphi| = n \quad (4.2)$$

The Malus law is valid in homogeneous and inhomogeneous media but not in anisotropic media, like some crystals.

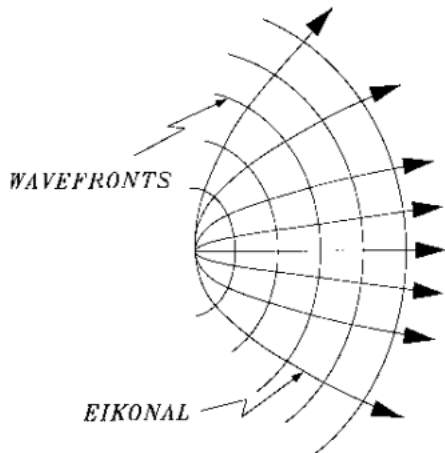

Figure 4.1 Propagation of wavefront and light rays (eikonal)

Fermat's Principle — This principle, which from the Malus law becomes a natural consequence, is the basis of all geometrical optics. It can be stated as follows: “The path traveled by a light wave from a point to another is stationary with respect to variations of this path.” This is equivalent to saying that the time for the light to travel must be either the longest or smallest time or be stationary with respect to other trajectories.

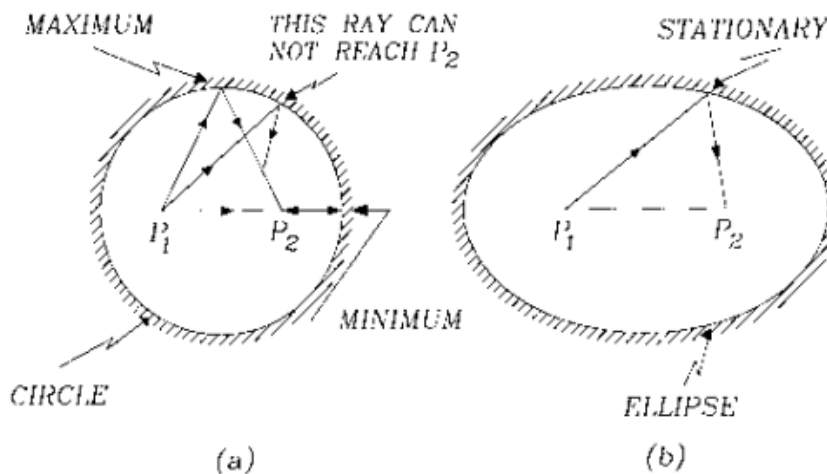

Figure 4.2 Illustration of Fermat's principle in a hollow sphere and a hollow elipsoid

Figure 4.2 shows some examples for two cases, in which the light must go from point P_1 to P_2 after being reflected in a mirror. In inhomogeneous [Figure 4.3(a)] or discontinuous [Figure 4.3(b)] media there may also be several physically possible trajectories for the light rays. In this case the point P_1 is the object and the point P_2 is its image. The optical path along all of these trajectories from the object to the image is the same. This constant optical path is called, in Hamilton's theory of geometrical optics, the

point characteristic of the system, because it depends only on the location of the initial and end points, not on the particular path.

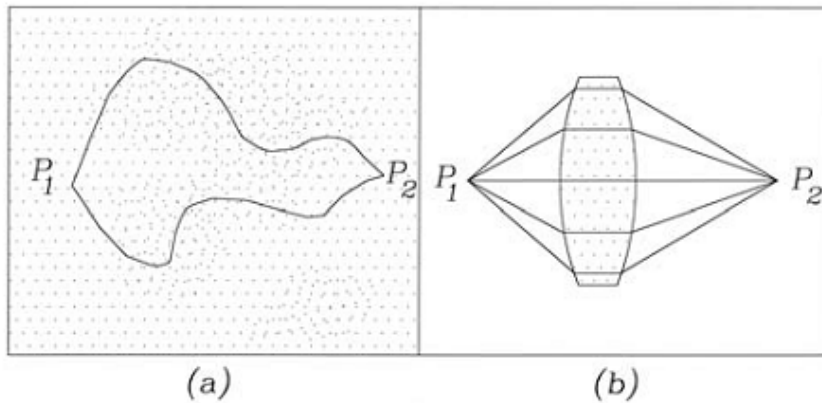

Figure 4.3 Optical path length from point P_1 to point P_2 are the same for any possible path

Reflection and refraction laws

Reflection and refraction laws can be derived in a simple way using Fermat's principle, as follows.

Reflection Laws

The first reflection law states that the incident ray, the reflected ray, and the normal to the reflecting surface lay on a common plane. This law can be explained as a consequence from Fermat's principle.

The second law states that the magnitude of the reflected angle is equal to the magnitude of the incident angle. Consider Figure 4.4, where a light ray leaves from point $P_1 (0, y_1)$ and reaches the point $P_2 (x_2, y_2)$ after a reflection on a plane mirror at the point $P(x, 0)$. If the refractive index is n , the optical path from P_1 to P_2 is

$$OP = n\sqrt{x^2 + y_1^2} + n\sqrt{(x_2 - x)^2 + y_2^2} \quad (4.3)$$

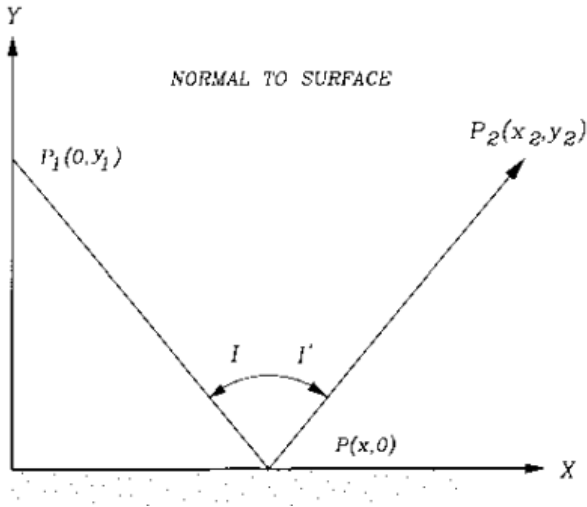

Figure 4.4 Derivation of the law of reflection

Since this optical path must be an extremum, we set the condition:

$$\frac{dOP}{dx} = \frac{nx}{\sqrt{x^2 + y_1^2}} - \frac{n(x_2 - x)}{\sqrt{(x_2 - x)^2 + y_2^2}} = 0 \quad (4.4)$$

and from this last equation, we can easily see that

$$\sin I = \sin I' \quad (4.5)$$

where the minus sign has been placed to introduce the convention that the angles I and I' have opposite signs because they are on opposite sides of the normal to the surface after reflection. Hence, we conclude that $I = I'$ which is the second reflection law.

Refraction Laws

The first refraction law states that the incident ray, the refracted ray, and the refracting surface normal lie in a common plane. This law is also an immediate consequence from Fermat's principle.

The second refraction law, called also Snell's Law, can be derived from Figure 4.5, where we can easily note that the optical path is given by

$$OP = n\sqrt{x^2 + y_1^2} + n'\sqrt{(x_2 - x)^2 + y_2^2} \quad (4.6)$$

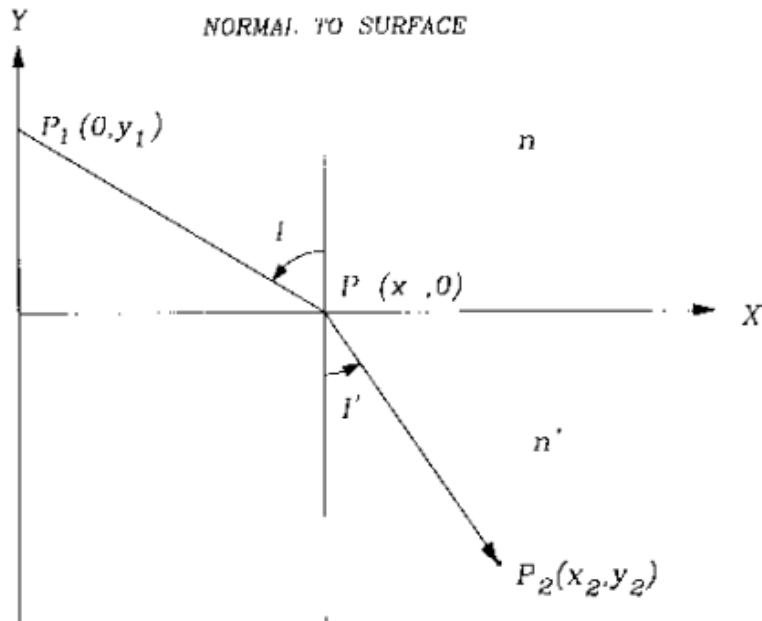

Figure 4.5 Derivation of the law of refraction.

By applying Fermat's principle, we impose the condition:

$$\frac{dOP}{dx} = \frac{nx}{\sqrt{(x^2 + y_1)^2}} - \frac{n'(x_2 - x)}{\sqrt{(x_2 - x)^2 + y_2^2}} = 0 \tag{4.7}$$

where we can see that: $n \sin l = n' \sin l'$ (4.8)

which is Snell's law. This relation becomes identical to the reflection law when the indices of refraction n and n' have the same magnitude but opposite sign. This fact is used to trace rays through optical systems with mirrors.

Daniel Malacara, ZacariasMalacara, Handbook of Optical Design

2.A. New Vocabulary

Find the explanations of the following terms in the text

Term	Defenition
geometrical path	
trajectory	
natural consequence	

reflection	
incident ray	
common plane	
reflecting surface	
reflected angle	
magnitude	
plane mirror	
refraction	
boundary	

2.B. In pairs, practice explaining the terms in Exercise 2A.

2.C. Complete the following extract using the words in the box.

N:comparison, contrast, direction, fiber, irregularity, outcome, scratch, virtue

DIFFUSE REFLECTION

Most objects are seen by _____¹ of their reflected light. For a "rough" surface, the law of reflection $\theta_r = \theta_i$, is obeyed at each point but the _____² of the surface cause the reflected rays to leave in many random _____³. It is called *diffuse reflection*. That is how you see this page, the wall, your hand, your friend, and so on. Diffuse reflection is far more prevalent than the mirror-like specular reflection.

By a "rough" surface, we mean a surface that is rough or irregular in _____⁴ to the wavelength of light. Because visible-light wavelengths are $\approx 0.5 \mu\text{m}$, any surface with texture, _____⁵, or other irregularities larger than $1 \mu\text{m}$ will cause diffuse reflection rather than specular reflection. A piece of paper may feel quite smooth to your hand, but a microscope would show that the surface consists of distinct _____⁶ much larger than $1 \mu\text{m}$. By _____⁷, the irregularities on a mirror or a piece of polished metal are much smaller than $1 \mu\text{m}$. The law of reflection is equally valid for both specular and diffuse reflection, but the nature of the surface causes the _____⁸ to be quite different.

2.D. Complete the following extract by underlining the correct word.

REVERSIBILITY OF LIGHT RAYS

The fact that _____¹ reflection displays equal angles of incidence and reflection means that there is a symmetry: if the ray had _____² from the right instead of the left, the angles would have looked exactly the same. It's a _____³ of a very deep and important fact about nature, which is that the laws of physics do not _____⁴ between past and future. Cannonballs and planets have _____⁵ that are equally natural in reverse, and so do light rays. This type of symmetry is called time-reversal symmetry. Typically, time-reversal symmetry is a characteristic of any process that does not involve heat.

The only situation where light does not _____⁶ time-reversal symmetry is absorption, which involves heat. Your skin absorbs visible light from the sun and heats up, but we never _____⁷ people's skin to glow, _____⁸ heat energy into visible light. People's skin does glow in infrared light, but that doesn't mean the situation is symmetric. Even if you absorb infrared, you don't emit visible light, because your skin isn't hot enough to glow in the visible _____⁹. These apparent heat-related asymmetries are not actual asymmetries in the laws of physics.

1	a) specular	b) mirror	c) glassy
2	a) gone	b) entered	c) come in
3	a) display	b) manifestation	c) example
4	a) discriminate	b) distinguish	c) differentiate
5	a) trajectories	b) paths	c) tracks
6	a) implement	b) conform	c) obey
7	a) observe	b) watch	c) spectate
8	a) converting	b) transforming	c) turning into
9	a) range	b) spectrum	c) band

2.E. Read the paragraphs below and put them into the correct order (the first one is A, the last one is G):

GEOMETRY OF SPECULAR REFLECTION

- A. To change the motion of a material object, we use a force. Is there any way to exert a force on a beam of light? Experiments show that electric and magnetic fields do not deflect light beams, so apparently light has no electric charge. Light also has no mass, so until the twentieth century it was believed to be immune to gravity as well.
- B. The phenomenon of reflection occurs only at the boundary between two media, just like the change in the speed of light that passes from one medium to another. This is the way all waves behave.
- C.
- The angle of the reflected ray is the same as that of the incident ray.
 - The reflected ray lies in the plane containing the incident ray and the normal (perpendicular) line. This plane is known as the plane of incidence
- D. Energy from the light beam is momentarily transformed into extra kinetic energy of the electrons, but because the electrons are accelerating they re-radiate more light, converting their kinetic energy back into light energy. We might expect this to result in a very chaotic situation, but amazingly enough, the electrons move together to produce a new, reflected beam of light, which obeys two simple rules:
- E. If we investigate how light is reflected by a mirror, we will find that the process is horrifically complex, but the final result is surprisingly simple. What actually happens is that the light is made of electric and magnetic fields, and these fields accelerate the electrons in the mirror.
- F. Einstein predicted that light beams would be very slightly deflected by strong gravitational fields, and he was proved correct by observations of rays of starlight that came close to the sun, but obviously that's not what makes mirrors and lenses work!
- G. Most people are surprised by the fact that light can be reflected back from a less dense medium. For instance, if you are diving and you look up at the surface of the water, you will see a reflection of yourself.

2.F. Read the text again and insert the connectives.

3.A. Using New Vocabulary

You are going to give a talk on the laws of geometrical optics. In part of the talk, you focus on the pictures below. Prepare your talk using the text and the pictures. Before preparing your talk, discuss the following terms and complete the pictures below.

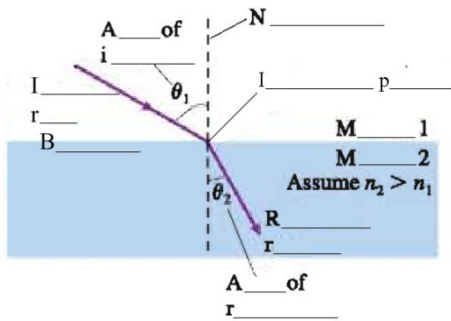
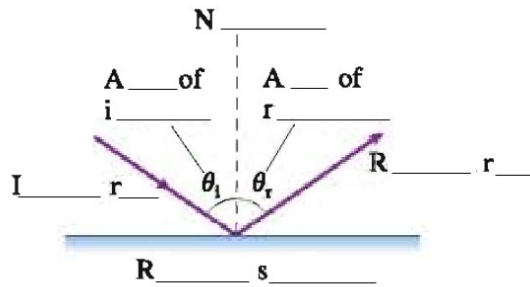

Figure 1 (a)



(b)

3.B. In small groups, take turns to give a talk.

4. A. Dialogue Work

Make up a dialogue of your own for one of the following situations (in pairs)
Situations:

1. **A.** is a student of ITMO University. **B.** is an physics teacher **A.** wants to know more about refraction and reflection laws.
2. **A.** reads an article “All Rays Lead to Geometrical Optics” **B.** wants to know more about geometrical optics.
3. **A.** is a first-year student of ITMO University, **B.** is an applicant. **B.** wants to know more about university courses.

ASKING FOR MORE INFORMATION

1. Can you tell me...?
2. Could you tell me...?
3. I'd like to know...
4. D'you know...
5. (Got / Have you) any idea...?
6. Could anyone tell me...?
7. (Do / Would) you happen to know...?
8. I don't suppose you (would) know...?
9. I wonder if you could tell me...?
10. I wonder if someone could tell me...?



4.B. Questions for free conversation and discussion.

- 1) Could you explain Fermat's Principle in your own words?
- 2) Explain the phenomena



- 3) Could you derive refraction law from the principle of least time? The figure II can help you.

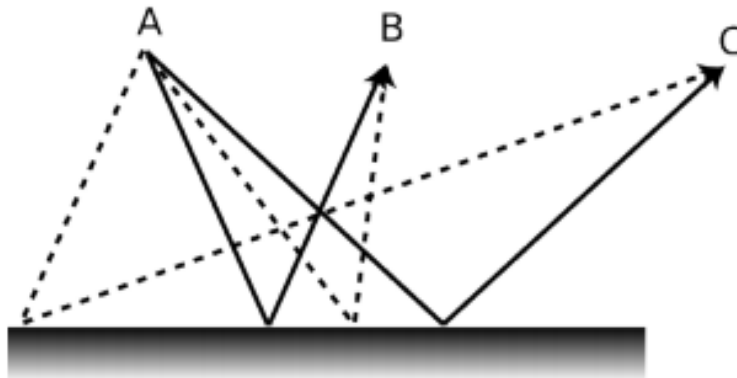

Figure II. The solid lines are physically possible paths for light rays traveling from A to B and from A to C. They obey the principle of least time. The dashed lines do not obey the principle of least time, and are not physically possible.

- 4) Could you derive reflection law from the principle of least time? The picture can help you.

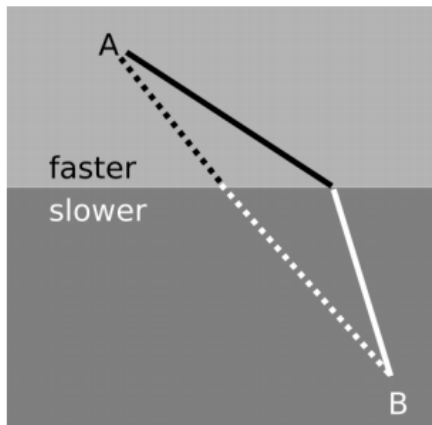
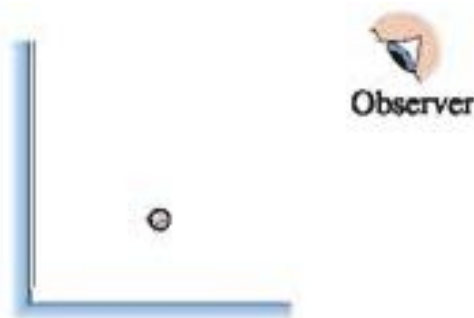

Figure III. The principle of least time applied to refraction.

- 5) Two plane mirrors form a right angle. How many images of the ball can you see in the mirrors? 1? 2? 3? 4?



6) Where is image formed by refraction? Use the figure to help you.

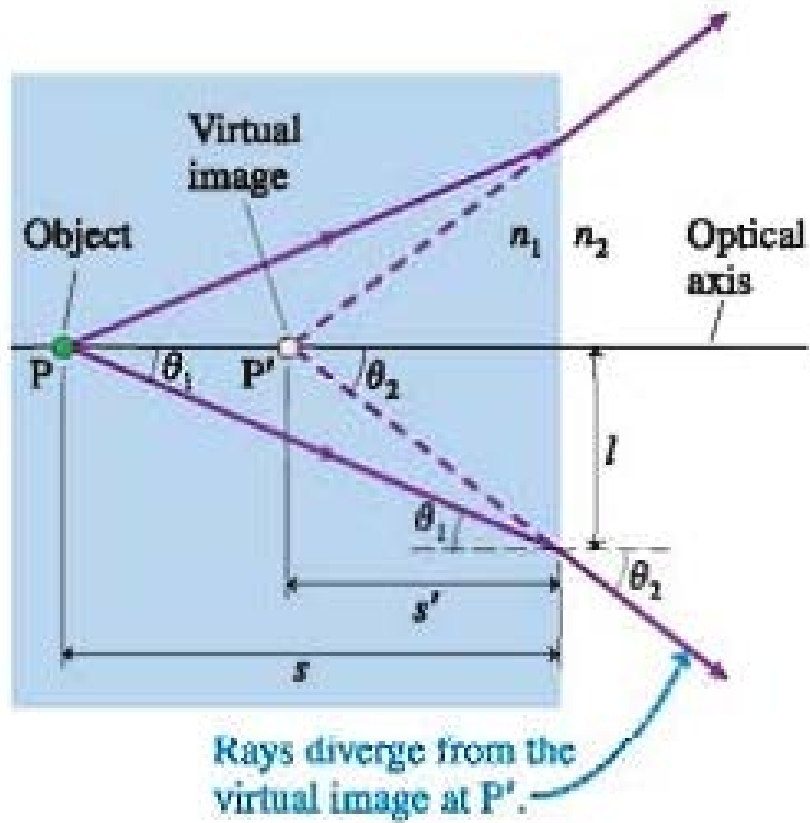
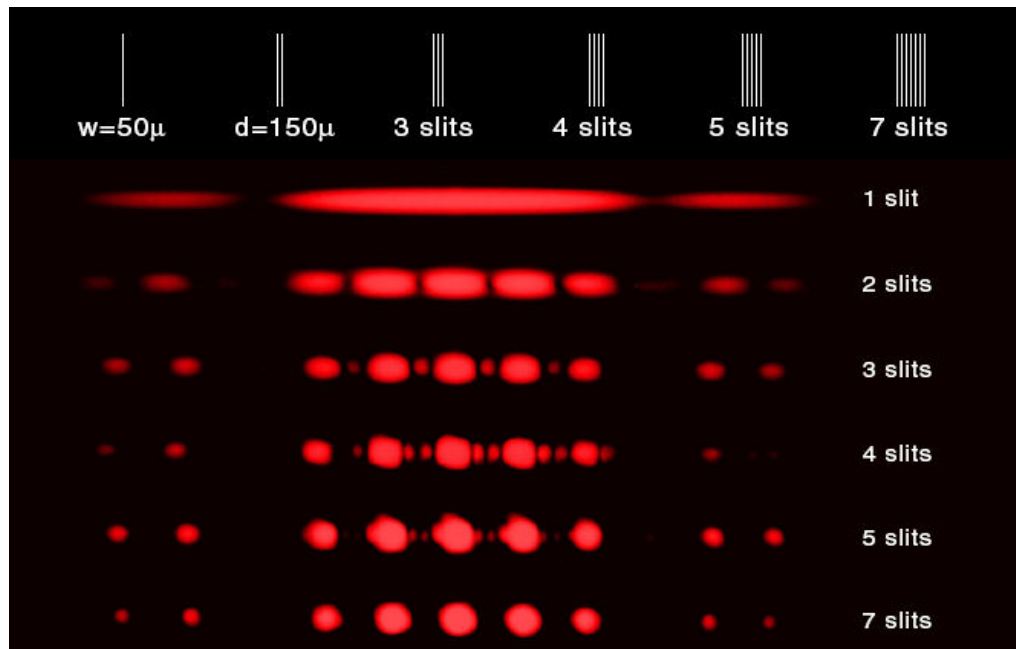

Figure IV. Finding the virtual image P' of an object at P . We've assumed $n_1 > n_2$

MAGIC WORLD OF OPTICS



Unit 5

INTERFERENCE AND DIFFRACTION

1. Explaining laws of interference and diffraction
2. Describing how they work
3. Emphasising technical terms
4. Simplifying and illustrating technical explanations

Magic World of Optics

INTERFERENCE AND DIFFRACTION

1.A. In pairs, look at the picture and discuss waves that pass through small gaps.



1.B. Read the following article and find the explanation of the phenomenon from Exercise 1.A

INTERFERENCE AND DIFFRACTION

If a stone is dropped into still water, a series of concentric ripples, or waves, is generated and spreads outward over the surface of the water. If two stones are dropped some distance apart, a careful observer will notice that where the waves from the two sources meet there are areas with waves twice as large as the original waves and also areas which are almost free of waves. This is because the waves can reinforce or cancel out the action of each other. Thus if the crests (or troughs) of two waves arrive simultaneously at the same point, the crest (or trough) generated is the sum of the two wave actions. However, if the crest of one wave arrives at the same instant as the trough of the other, the result is a cancellation.

Similar phenomena occur when light waves are made to interfere. In general, light from the same point on the source must be made to travel two separate paths and then be recombined, in order to produce optical interference. The familiar colors seen in soap bubbles or in oil films on wet pavements are produced by interference.

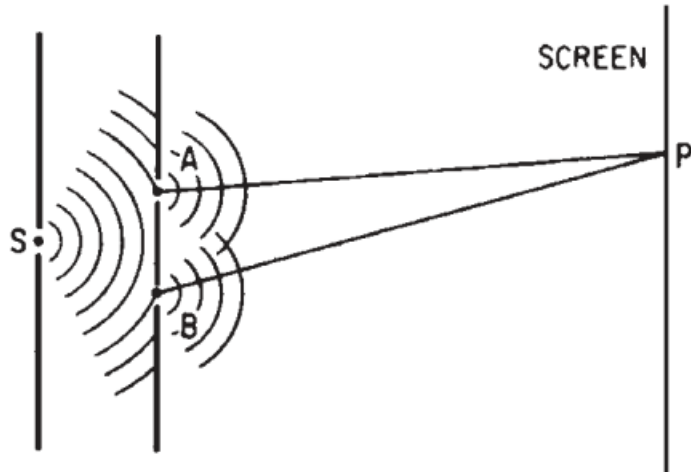

Figure 5.1 Young's diffraction experiment

Young's experiment, which is diagramed schematically in Figure 5.1, illustrates both diffraction and interference. Light from a source to the left of the figure is caused to pass through a slit or pinhole s in an opaque screen. According to Huygens' principle, the propagation of a wave front can be constructed by considering each point on the wave front as a source of new spherical wavelets; the envelope of these new wavelets indicates the new position of the wave front. Thus s may be considered as the center of a new spherical or cylindrical wave (depending on whether s is a pinhole or a slit), provided that the size of s is sufficiently small. These diffracted wave fronts from s travel to a second opaque screen which has two slits (or pinholes), A and B , from which new wave fronts originate. The wave fronts again spread out by diffraction and fall on an observing screen some distance away.

Now, considering a specific point P on the screen, if the wave fronts arrive simultaneously (or in phase), they will reinforce each other and P will be illuminated. However, if the distances AP and BP are such that the waves arrive exactly out of phase, destructive interference will occur and P will be dark.

If we assume that s , A , and B are so arranged that a wave front from s arrives simultaneously at A and B (that is, distance sA exactly equals distance sB), then new wavelets will start out simultaneously from A and B toward the screen. Now if distance AP exactly equals distance BP , or if AP differs from BP by exactly an integral number of wavelengths, the wave fronts will arrive at P in phase and will reinforce. If AP and BP differ by one-half wavelength, then the wave actions from the two sources will cancel each other.

If the illuminating source is monochromatic, i.e., emits but a single wavelength of light, the result will be a series of alternating light and dark bands of gradually changing intensity on the screen (assuming that s , A , and B are slits), and by careful

measurement of the geometry of the slits and the separation of the bands, the wavelength of the radiation may be computed. (The distance AB should be less than a millimeter and the distance from the slits to the screen should be to the order of a meter to conduct this experiment.)

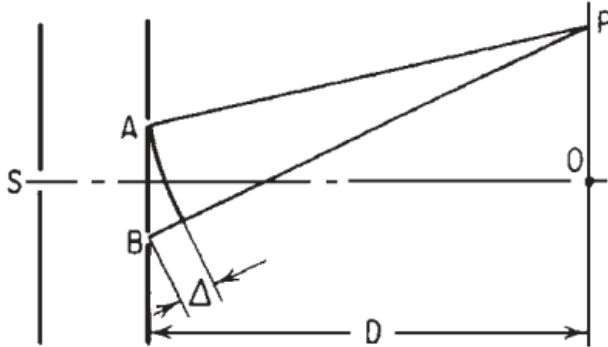

Figure 5.2 geometry of Young's experiment

With reference to Figure 5.2, it can be seen that, to a first approximation, the path difference between AP and BP, which we shall represent by Δ , is given by

$$\Delta = \frac{AB \cdot OP}{D} \quad (5.1)$$

Rearranging this expression, we get

$$OP = \frac{\Delta \cdot D}{AB} \quad (5.2)$$

Now as Figure 5.2 is drawn, it is obvious that the optical paths AO and BO are identical, so the waves will reinforce at O and produce a bright band. If we set Δ in Eq. 5.2 equal to (plus or minus) one-half wave-length, we shall then get the value of OP for the first dark band

$$OP \text{ (1st dark)} = \frac{\pm \lambda D}{2AB} \quad (5.3)$$

If the light source, instead of being monochromatic, is white and consists of all wavelengths, it can be seen that each wavelength will produce its own array of light and dark bands of its own particular spacing. Under these conditions the center of the screen will be illuminated by all wavelengths and will be white. As we proceed from the center, the first effect perceptible to the eye will be the dark band for blue light which will occur at a point where the other wavelengths are still illuminating the screen. Similarly, the

dark band for red light will occur where blue and other wavelengths are illuminating the screen. Thus a series of colored bands is produced, starting with white on axis and progressing through red, blue, green, orange, red, violet, green, and violet, as the path difference increases. Further from the axis, however, the various light and dark bands from all the visible wavelengths become so “scrambled” that the band structures blend together and disappear.

Warren J. Smith, Modern Optical Engineering, The Design of Optical Systems

2.A. New Vocabulary

Find the explanations of the following terms in the text

Term	Definition
slit	
concentric ripples	
reinforce	
cancel out	
trough	
simultaneously	
pinhole	
opaque	
wavelet	
crest	
destructive interference	
alternating band	
array of bands	
diffraction pattern	
monochromatic	

2.B. In pairs, practice explaining the terms in Exercise 2A.

2.C. Match 1-6 with a-f and complete the sentences.

1	Huygens' principle says that each point on wave front is the source of a spherical wavelet	a	two or more waves as they spread behind opening.
2	Diffraction is a spreading of	b	The wave front at later time is tangent all the wavelets
3	Constructive and destructive interference are due to the overlap of	c	one wave travels an integer number of wavelengths more or less than the other wave.
4	Interference is constructive if	d	a wave after it passes through an opening.
5	Destructive interference is the interaction of superimposed light from	e	Diffraction effects are usually important.
6	We use the wave model when passes through opening <1 mm in size	f	two separate sources that results in a combined intensity that is less than the sum of their individual intensities before they were superimposed.

2.D. Write four or five sentences about interference and diffraction. Use the highlighted terms from 2.C.

2.E. Complete the following text using the correct form of the verbs in the box.

V: appear, assume, calculate, emit, explain, interfere, postulate

There are many theories that _____¹ diffraction phenomena, but the simplest one is the Huygens–Fresnel theory, which is surprisingly accurate in most cases. This theory _____² that a wavefront may be considered to _____³ secondary wavelets as passing through an aperture.

This secondary Huygens wavelets were _____⁴ by Christian Huygens in 1678 in Holland, but this theory was not enough to explain diffraction effects quantitatively. Many years later, in 1815 in France, Augustin Arago Fresnel considered that Huygens wavelets must _____⁵ with their corresponding phase when arriving at the observing screen. This theory is sufficient to explain all diffraction effects, which _____⁶ in optical systems, with the exception of the value of the resulting phase.

However, the irradiance values for a point light source (plane wavefront) can be _____⁷ extremely accurate.

In any diffraction experiment the important elements are the light source, the diffracting aperture, and the observing screen. If any of the two distances, the distance from the light source to the diffracting aperture or the distance from the diffracting aperture to the observing screen, or both, are finite, we have the so called Fresnel diffraction theory. If both distances are infinite, then we have a Fraunhofer diffraction configuration.

2.F. Use the words in brackets to form a word that fits in each gap.

CIRCULAR-APERTURE DIFFRACTION

Diffraction occurs if a wave passes through an _____¹ (open) of any shape. Diffraction by a single slit establishes the basic ideas of diffraction, but a common situation of practical _____² (important) is diffraction of a wave by a **circular aperture**. Circular diffraction is _____³ (mathematic) more complex than diffraction from a slit, and we will present results without _____⁴ (derivate).

Consider some examples. A loudspeaker cone generates sound by the rapid _____⁵ (oscillate) of a diaphragm, but the sound wave must pass through the circular aperture defined by the _____⁶ (out) edge of the speaker cone before it travels into the room beyond. This is diffraction by a circular aperture. Telescopes and microscopes are the reverse. Light waves from outside need to enter the instrument. To do so, they must pass through a _____⁷ (circle) lens. In fact, the _____⁸ (perform) limit of optical instruments is determined by the diffraction of the circular openings through which the waves must pass.

Light waves passing through this aperture spread out to generate a *circular* diffraction pattern. The diffraction pattern has a *central maximum*, now circular, and it is surrounded by a series of _____¹⁰ (second) bright fringes. Most of the _____¹¹ (intense) is contained within the central maximum.

Angle θ_1 locates the first minimum in the intensity, where there is perfect _____¹² (destruct) interference. A _____¹³ (mathematic) analysis of circular diffraction finds $\theta_1 = 1,22\lambda/D$

where D is the *diameter* of the circular opening. This is very similar to the result for a single slit, but not quite the same. This equation has assumed the small-angle _____¹⁴ (approximate), which is almost always valid for the diffraction of light but usually is *not* valid for the diffraction of longer-wavelength sound waves.

2.G. Complete the following extract using the right terms in the box.

beam –combiners, beam-splitters, the interference of light waves, an interference pattern, phase difference, a photographic plate, a reference beam, surface profile, fringe pattern

INTERFEROMETRY

Interferometry is a technique of measurement that employs _____¹, and the devices using this technique are known as interferometers. These use an arrangement to generate two beams, one of which acts as _____² and other is a test beam. The test beam gathers information about the process to be measured or monitored. These two beams are later combined to produce _____³ that arises from the acquired _____⁴. Interferometers based on division of amplitude use _____⁵ for splitting the beam into two and later combining them for interference. Ingenuity lies in designing beam-splitters and _____⁶. The interference pattern is either recorded on _____⁷ or sensed by a photodetector or array-detector device. Currently charge-coupled device (CCD) arrays are used along with phase-shifting to display the desired information such as _____⁸, height variation, and refractive index variation. Observation of the _____⁹ is completely hidden in the process.

3.A. Using New Vocabulary

You are going to give a talk on the laws of diffraction and interference. In part of the talk, you focus on the pictures below. Prepare you talk using the texts and the pictures.

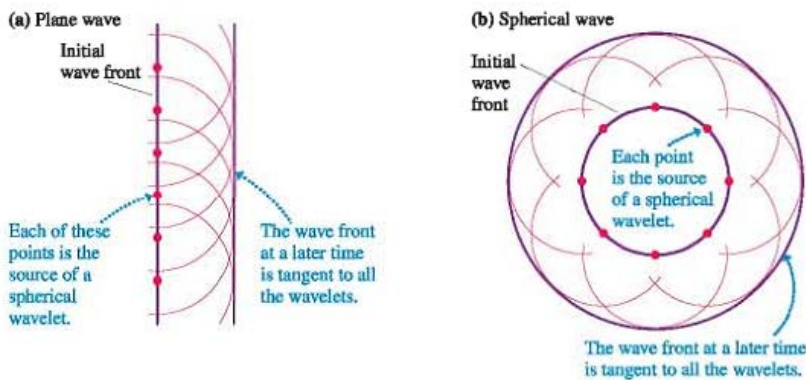

Figure 1. Huygens' principle applied to the propagation of plane and spherical waves.

3.B. In small groups, take turns to give a talk.

4.A. Dialogue Work

Make up a dialogue of your own for one of the following situations (in pairs)
Situations:

1. **A.** and **B.** are two group mates. They talk about the new seminar "Interference and Diffraction". **A.** likes the seminar. **B.** does not agree.
2. **A.** meets his/her colleague **B.** at a library. **B.** is preparing for his/her speech at a conference. **A.** helps **B.** with new arguments. **B.** agrees.
3. **A.** is a postgraduate making a research "Interference and Diffraction". **B.** is a bachelor student. **B.** does not agree with **A's** arguments.

Agreeing	Disagreeing
<ul style="list-style-type: none"> • I agree. • I agree with you 100 percent. • I couldn't agree with you more. • That's so true. • That's for sure. • That's exactly how I feel. • I feel the same way. • I think so too. • You have a good point there. • I was just going to say that. • I had that same idea. • Exactly. • You're absolutely right. • Absolutely! • I have to side with Janet on this one. • No doubt about it! • You nailed it on the head. 	<ul style="list-style-type: none"> • I disagree. • I totally disagree. (strong) • I don't think so. • I'm afraid I disagree. • I beg to differ. • Not necessarily. • That's not always true. • That's not always the case. • I'm not so sure about that. • No way. (strong and informal) • I'd say the exact opposite. (strong)

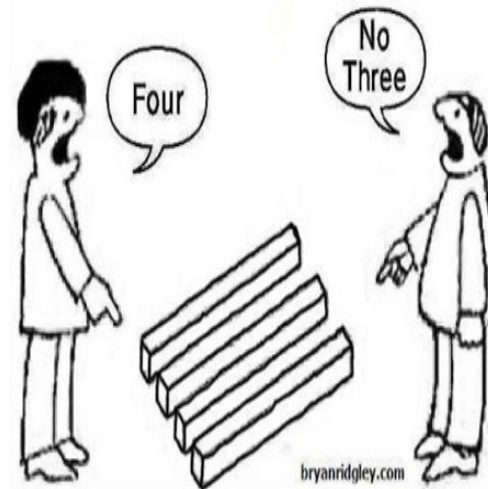

4.B. Questions for free conversation and discussion.

- 1) What is the difference between interference and diffraction?
- 2) How would you explain interference to a small kid?
- 3) Explain the pictures

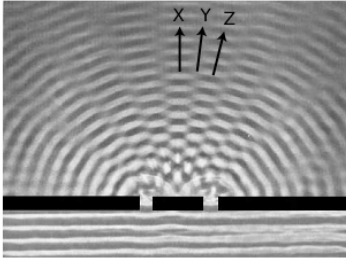
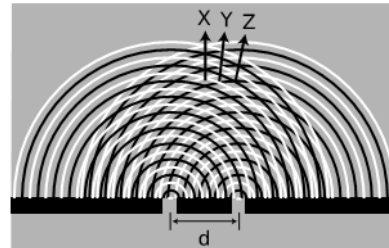

Figure II. (a) Double-slit diffraction



(b) Use of Huygens' principle

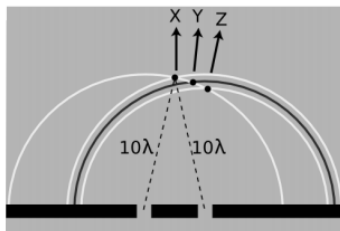
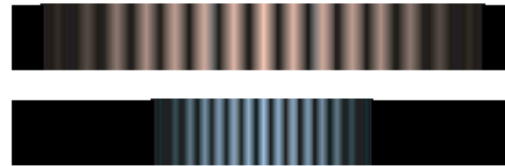

Figure III (c) Constructive interference along the central line



(d) Double-slit diffraction patterns of long-wavelength red light (top) and short-wavelength blue light (bottom)

- 4) Derive double-slit interference maxima as $d \sin \theta = n\lambda$, where n is any integer. Use figure IV for help.

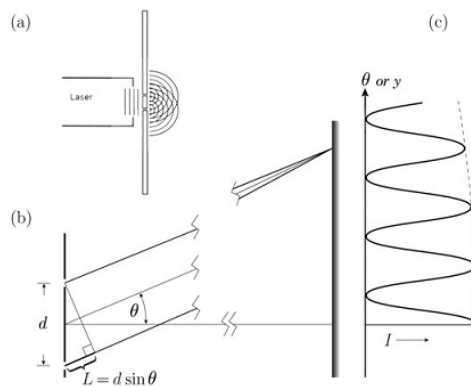

Figure IV. Geometry for double-slit interference experiment. (a) two side-by-side slits, with their long dimension perpendicular to the plane of page, serve as in-phase sources of light; variation of the path difference L with angle θ ; (c) intensity of interference pattern on a screen far from the sources.

MAGIC WORLD OF OPTICS



App. 1

PRESENTATION

Magic World of Optics

PRESENTATION

TIPS ON MAKING PRESENTATIONS

If you can't explain it simply, you don't understand it well enough
Albert Einstein

As part of an extended interview/selection centre you may be asked to give a short presentation. Usually you choose the topic from a list which may include **your hobbies, a recent holiday, a current affairs topic or one of your achievements**, or sometimes you may be asked to make a presentation on a case study you have previously done as part of the extended interview. The purpose is not to test your subject knowledge, but to see how well you can speak in public. **Typically you will be asked to talk for five minutes**, and will be given 20 or 30 minutes beforehand to prepare.



BASIC TIPS

- **Dress smartly:** don't let your appearance distract from what you are saying.
- **Smile.** Don't hunch up and shuffle your feet. Have an upright posture. Try to appear confident and enthusiastic.
- **Say hello and smile when you greet the audience:** your audience will probably look at you and smile back: an instinctive reaction.
- **Speak clearly,** firmly and confidently as this makes you sound in control. Don't speak **too quickly:** you are likely to speed up and raise the pitch of your voice when nervous. Give the audience time to absorb each point. Don't talk in a monotone the whole time. Lift your head up and address your words to someone near the back of audience. If you think people at the back can't hear, ask them.

- **Use silence** to emphasise points. Before you make a key point pause: this tells the audience that something important is coming. It's also the hallmark of a confident speaker as only these are happy with silences. Nervous speakers tend to gabble on trying to fill every little gap.
- **Keep within the allotted time** for your talk.
- **Eye contact is crucial to holding the attention of your audience.** Look at everyone in the audience from time to time, not just at your notes or at the PowerPoint slides. Try to involve everyone, not just those directly in front of you.
- **Walk around a little and gesture with your hands.** Bad presenters keep their hands on the podium or in their pockets! Don't stand in one place glued to the spot hiding behind the podium! Good presenters will walk from side to side and look at different parts of the audience.
- You could try to **involve your audience** by asking them a question.
- Don't read out your talk, as this sounds boring and stilted, but **refer to brief notes** jotted down on small (postcard sized) pieces of card. **Don't look at your notes too much** as this suggests insecurity and will prevent you making eye contact with the audience.
- It's OK to use **humour**, in moderation, but better to use anecdotes than to rattle off a string of jokes.
- Take along a **wristwatch** to help you keep track of time – the assessor may cut you off as soon as you have used the time allocated, whether or not you have finished.
- It can be very helpful to **practise at home** in front of a mirror. You can also record your presentation and play it back to yourself: don't judge yourself harshly when you replay this - we always notice our bad points and not the good when hearing or seeing a recording or ourselves! Time how long your talk takes. Run through the talk a few times with a friend.
- **It's normal to be a little nervous.** This is a good thing as it will make you more energised. Many people have a fear of speaking in public. Practising will make sure that you are not too anxious. In your mind, visualise yourself giving a confident successful performance. Take a few deep slow breaths before your talk starts and make a conscious effort to speak slowly and clearly. Research

A BBC presenter once sat next to Winston Churchill as he gave a speech in which he kept his audience hanging on every word. The presenter noticed that what appeared to be notes in his hand was in fact just a laundry slip.

Later he mentioned this to Churchill. "Yes", said Churchill *"It gave confidence to my audience."*

by T Gilovich (Cornell University) found that **people who feel embarrassed are convinced their mistakes are much more noticeable than they really are**: we focus on our own behaviour more than other people do and so overestimate it's impact. This is called the spotlight effect. If you make a mistake, don't apologise too much, just briefly acknowledge the mistake and continue on. For more details see ["59 Seconds" by Prof. Richard Wiseman](#)

- **Build variety into the talk** and break it up into sections: apparently, the average person has a three minute attention span!

<p>Structure Have a logical order: introduction, middle with your main points & a conclusion</p>	<p>Practice Practice beforehand in front of a mirror, with a recorder or in front of a friend</p>	<p>Body Language Smile, make eye contact, stand up straight & move around a bit. Don't hide behind the podium!</p>
<p>Notes & Handouts Have brief notes on postcard sized cards. Have a handout that the audience can take away afterwards</p>	<p>PRESENTATION SKILLS</p> <p>Bruce Woodcock, bw@kent.ac.uk University of Kent Careers</p>	<p>Speech Speak clearly, confidently, concisely & not too fast. Use everyday language rather than jargon</p>
<p>PowerPoint Keep slides clean & simple. Don't have lots of text on each slide. Use charts, diagrams & pictures</p>	<p>Interaction Build a rapport with your audience. Get them involved by asking & encouraging questions. Use humour if appropriate</p>	<p>Nervousness It's normal to be a bit nervous: this helps make you more energised. Preparation & practice will reduce nerves!</p>

HAVE A STRUCTURE

Have a beginning, middle and an end. Use short sentences.

Consider:

- Who are the audience?

- What points do I want to get across?
- How much time have I got?
- What visual aids are available? Powerpoint projector? Flip chart? Don't necessarily use these. Sometimes the best presentations are the most informal.

Introduction

- **Welcome** the audience.
- **Say what your presentation will be about:** the aims and objectives.
- The introduction should catch the attention. Perhaps a provocative statement or a humorous anecdote:
 - “Genetically-modified crops could save millions of people from starvation”
 - “The first day of my vacation job went with a bang, but it wasn't my fault that the microwave exploded.

The Middle should outline your argument or develop your story

- In five minutes **you will only have time for two or three main points** and allow everything else to support these. List your main headings and any key phrases you will use.
- **Don't try to say pack too much content in** or you will talk non- stop trying to get all your content and the audience will switch off with information overload long before the end.
- Use graphics or anecdotes to add variety.

Conclusion

- Briefly **summarise** your main points.
- **Answer any questions.**
- **Thank the audience** for listening. Look at the audience again, **smile** and slow down.
- **The end should be on a strong or positive note** – not tailing away to “..well that's all I've got to say so thank you very much for listening ladies and gentlemen”. You could try something along the selines:
 - “Hang-gliding is brilliant, so try it – you'll believe a man can fly!”

- “The danger is increasing – if we don't all act soon it could be too late!

The above has been neatly summarised as **"Tell them what you will tell them (introduction), tell them (development), tell them what you told them (conclusion)"**

In preparing your talk, first jot down any interesting points you want to include in your talk, put these in a logical sequence, then try to find an interesting title, and a good introduction and ending.

The ten most common mistakes in public speaking

According to Terry Gault the most common mistakes are:

- Using small scale movements and gestures
- Speaking with low energy
- Playing it safe
- Not preparing enough
- Not practicing enough
- Preparing too much material
- Rushing
- Data centric presentations
- Avoiding vulnerability
- Taking themselves way too seriously

For more about this see [10 Most Common Rookie Mistakes in Public Speaking](#)

USING POWERPOINT, OVERHEAD PROJECTOR OR FLIP CHART

You may be allowed to use an overhead projector(OHP), data projector, or flip chart as part of your talk, If you think that you might like to use one, then it's wise to try to practice on one beforehand so you know what you are doing!

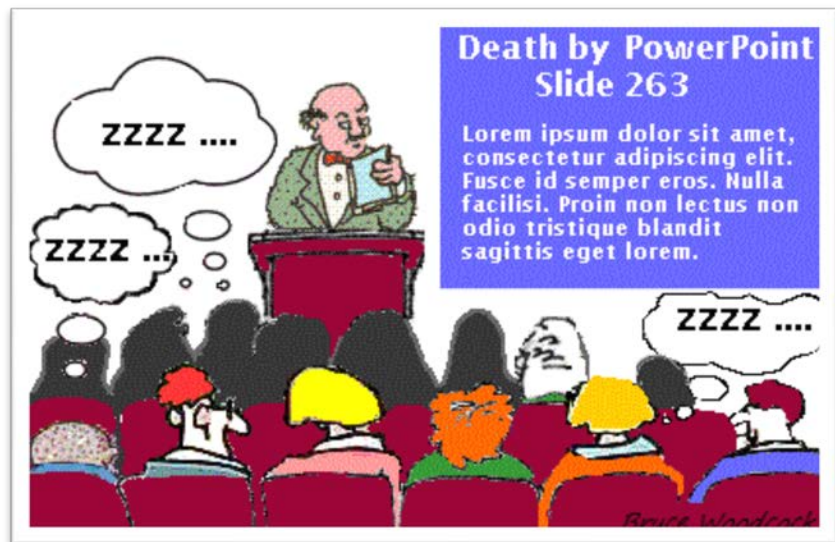

- Before you start **check the computer and the lighting:** make sure no bright lights are illuminating the screen.
- **Stand to one side** of the projector/flip chart, so the audience can see the material.
- **Face and speak to your audience, not the screen.** Inexperienced PowerPoint presenters have their backs to the audience most of the time!

- **All too often the slides are just a security blanket for the speaker**, not visual aids for the audience.
- **Don't use too many slides:** three or four should be sufficient for a short presentation. For a 15 minute session 8 would be the absolute maximum and probably less. Don't have too much text on each slide - no more than about 40 words. Each slide should last for at least 2 minutes. The more slides and the more words on each slide, the less the audience will listen- whereas the less and simpler slides you have, the better you will communicate. Plan your presentation carefully and only use slides where they will clarify points.
- **Don't try to write too much** on each slide: 30 to 40 words in a large font size is ample for one transparency. Use note form and bullets rather than full sentences. It is very hard for a member of the audience to read slides and listen simultaneously - they are unlikely to do either well. **The best slides contain just one word.**
- **Slides can contain prompts** to remind you of what you will say next.
- **Press w to blank the screen or** or b to black it out (pressing any key restores the slides) when talking about a point which does not require a slide thus reducing the distraction for the audience.
- **Use a large (about 24 point) SANS font** such as Verdana or Lucida Sans. **DON'T PUT EVERYTHING IN UPPER CASE AS THIS LOOKS CRUDE.** Check that the slides are easy to read from a distance.
- **Use colour and bold for emphasis** but don't use too much colour. Have a good contrast e.g. dark blue text on a cream background.
- **Pictures, especially tables, diagrams and charts** are good. Powerpoint is excellent for the delivery of pictures and diagrams and they will help to break up and add variety to the long streams of text seen in many (bad!) presentations.
- A little **humour** can grab the attention of the audience. For example some [performing crocodiles?](#)
- **Don't get carried away with flashy PowerPoint transition effects** as these may distract attention from the content.
- If using **PowerPoint** use the **Format|Apply design template** command. Gives you a wide range of nicely preformatted slide designs to choose from and saves you a lot of time.

Dark blue on white or cream gives a good contrast,

whereas red text on a green background is harder to read

The average PowerPoint slide contains 40 words

- **Write down your main points on a postcard sized piece of card** as a prompt and also as a backup in case the technology fails!
- **Too many bullets can machine gun your audience to sleep!** Good presentations will have a variety of slides: some with bullets, some without and many with images and charts. Twenty slides with 5 bullets on each means you are trying to get across one hundred points, whereas the average person will absorb *at most* 5 points from a presentation.

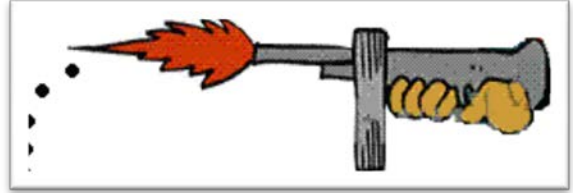

Less is more!

The best speakersgrip an audience by telling a story and showing some slides to support that.

Meinald Thielsch

I'm going to make a long speech because I've not had time to prepare a short one.

Winston Churchill

The secret of a good sermon is to have a good beginning and a good endingand to have the two as close together as possible.

Make a presentation or a short report on one of the following topics:

- 1) Vision defects and their correction.
- 2) How to improve our vision.
- 3) Differences in human and animal vision.
- 4) What do you know about ancient vision models?
- 5) Colure vision.
- 6) Optical illusions.
- 7) Newton, Huygens, Young and Einstein ...
- 8) Photon model of light.
- 9) Total internal reflection.
- 10) Rainbow
- 11) Fresnel diffraction / Fraunhofer diffraction
- 12) Interferometry and Interferometers
- 13) Negative refraction index phenomenon and metamaterials

MAGIC WORLD OF OPTICS

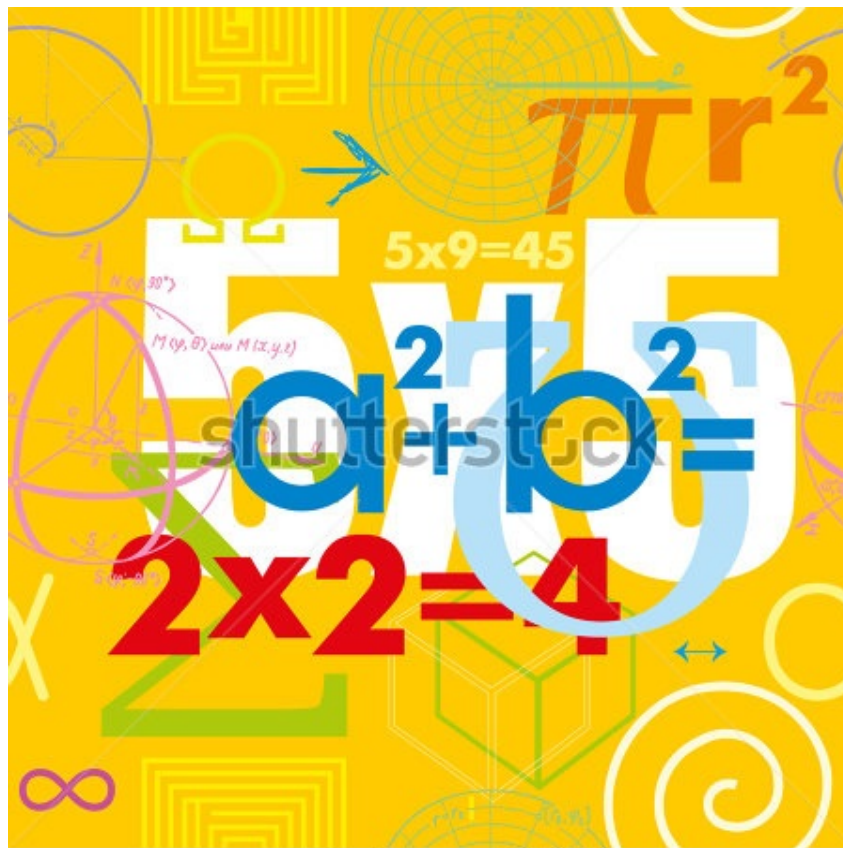

App. 2

MATH FORMULAS AND SYMBOLS

SYMBOLS AND FORMULAS

+	plus/ and
-	minus/ take away
\pm	plus or minus
*	(is) multiplied by/ times
\div	(is) divided by
=	is equal to/equals
\neq	is not equal to/ does not equal
\approx	is approximately equal
()	brackets
[]	square brackets
{ }	curly brackets
<	is less than
>	is more than
\leq	is less than or equal to
\geq	is more than or equal to
%	per cent
°	degree
'	minute (of an arc)
''	second (of an arc)

\rightarrow	approaches, tends to, corresponds to
∞	infinity
\emptyset	empty set
N, №	number
1/2	one half, a half
1/3	one third
4/7	four sevenths
$2\frac{1}{3}$	two and a third
0.3	nought point three, zero (nill, null) point three
2.4	two point four
$a+b=c$	a plus b equals c
$a*b=c$	a multiplied by b equals c
$a\div b=c$	a divided by b is equal to c
$(a+b)*$ $(a-b)=a^2-b^2$	the product of the sum and difference of two quantities is equal to the difference of their squares
3:9=4:16	three is to nine, as four is to sixteen-proportion
$\sqrt{\quad}$	(square) root;
$\sqrt[3]{a}$	the cube root of a
$\sqrt[5]{x}$	the fifth root of x
$\sqrt[n]{a}$	the n th root of a
x^2	x squared; 3^2 – tree squared or the second power of

	three
x^3	x cubed; 5^3 – five cubed or the third power of five
x^4	x to the power four/to the forth; 5^4 – five to the power of four
$\log_b(x)$	the logarithm of x to <i>base</i> b
\log_e	natural logarithm to the base e
\ln	natural logarithm
\sphericalangle	angle
\perp	right angle
\perp	is perpendicular
\parallel	is parallel to
Δ	triangle
\square	square
\circ	round, circle
π	pi
r	radius of circle
πr^2	pi r squared – formula for area of circle
μ	micron
\subset	belongs to
$a \in A$	the element a is contained in the set A
$a \notin A$	the element a is not contained in the set A

A'	A prime
B_1	B sub one
C_b	C sub b
$f(x)$	function of x
$R(x)$	R of x
$\min f(x)$	minimum value of $f(x)$ over allowed range of x
$\max f(x)$	maximum value of $f(x)$ over allowed range of x
dx	differential of x
dy / dx	the first derivative of y with respect to x
\int	integral from ... to ... of ... with respect to
$\text{Lim } x \rightarrow y$	limit as x approaches y
$\text{Lim } \rightarrow y^+$	limit as x approaches y from above
$\text{Lim } \rightarrow y^-$	limit as x approaches y from below
Σ	sum
$A \cup B$	union of sets A and B (that is, the set of elements in A or B or both)
$A \cap B$	intersection of sets A and B (that is, the set of elements commonly contained in sets A and B)
$\nabla f(x)$	gradient of the function of x

GREEK ALPHABET

Αα	alpha	Νν	nu
Ββ	beta	Ξξ	xi
Γγ	gamma	Οο	omicron
Δδ	delta	Ππ	pi
Εε	epsilon	Ρρ	rho
Ζζ	zeta	Σσς	sigma
Ηη	eta	Ττ	tau
Θθ	theta	Υυ	upsilon
Ιι	jota	Φφ	phi
Κκ	kappa	Χχ	chi
Λλ	lambda	Ψψ	psi
Μμ	mu	Ωω	omega

Literature

1. Benjamin Crowell, Simple Nature An Introduction to Physics for Engineering and Physical Science Students, Light and Matter, 2008
2. Charles H. Holbrow, James N. Lloyd, Joseph C. Amato, Enrique Galvez, M. Elizabeth Parks, Modern Introductory Physics, second edition, Springer, 2010
3. Randall D. Knight, PHYSICS for scientists and engineers A STRATEGIC APPROACH, second edition, Pearson, 2008
4. Daniel Malacara, Zacarias Malacara, Handbook of Optical Design, Marcel Dekker, 2004
5. Warren J. Smith, Modern Optical Engineering, The Design of Optical Systems, third Edition, SPIE Press, 2000
6. The Photonics Dictionary 2008, 54th International Edition, A Laurin Publication

Миссия университета – генерация передовых знаний, внедрение инновационных разработок и подготовка элитных кадров, способных действовать в условиях быстро меняющегося мира и обеспечивать опережающее развитие науки, технологий и других областей для содействия решению актуальных задач.

КАФЕДРА ИНОСТРАННЫХ ЯЗЫКОВ

Кафедра иностранных языков Университета ИТМО образовалась в 2015 году в результате слияния кафедры иностранных языков ИТМО и кафедры иностранных языков Института Холода и Биотехнологий и стала одной из самых многочисленных учебных подразделений Университета. Произошло соединение опыта двух гуманитарных кафедр вузов преимущественно технического направления, которые успешно функционировали на протяжении многих лет в тесной связи с профильными кафедрами.

Общим для обеих кафедр всегда был основной принцип деятельности: иностранный язык это не второстепенный предмет в техническом вузе, которому может уделяться мало внимания, и тем более не вспомогательный инструмент обучения, которым можно воспользоваться, а можно и пренебречь, а равноправный субъект обучения. На протяжении многих лет велась совместная работа с выпускающими кафедрами ВУЗов, взаимное влияние специальных дисциплин и иностранных языков давало конкретные положительные результаты.

Преподаватели и сотрудники кафедр иностранных языков работают над пособиями для всех специальностей совместно с преподавателями и сотрудниками выпускающих кафедр, слушают специальные лекции, совместно работают над статьями в ведущие научные журналы. В результате созданы уникальные регулярно обновляемые авторские пособия по огромному спектру специальностей. Студенты младших курсов подчас знакомятся с основами своей специальности на иностранном языке раньше, чем это происходит на русском, при этом это делается профессионально и грамотно.

Для кафедры иностранных языков ИТМО было характерно широкое использование компьютерных технологий в обучении, информатизация учебного процесса; кафедра иностранных языков ИХиБТ уделяла большее внимание теории и практике перевода и общения на иностранном языке на профессиональные темы. Объединение этих двух стратегий подготовило почву для того, чтобы переход на новые принципы обучения стал естественным и единственно возможным шагом вперед.

Светлана Евгеньевна Калабина
Валерия Олеговна Кулешова

Magic World of Optics

Учебно-методическое пособие

В авторской редакции

Дизайн

Верстка

Редакционно-издательский отдел Университета ИТМО

Зав. РИО

Подписано к печати 27.05.16

Заказ № 3699

Тираж 100

Отпечатано на ризографе

В.О. Кулешова

С.Е. Калабина

Н.Ф. Гусарова

Редакционно-издательский отдел
Университета ИТМО
197101, Санкт-Петербург, Кронверкский пр., 49