



St Petersburg  
University

**XII International Conference on Chemistry  
for Young Scientists "MENDELEEV 2021"**

Book of abstracts contains theses of plenary, keynote, oral and poster presentations which were presented on **Mendeleev 2021**, the XII International Conference on Chemistry for Young Scientists. The Mendeleev 2021 Conference hold in Saint Petersburg (September 6–10, 2021).

ISBN 978-5-9651-1364-4

Abstracts presented in the original edition

## GENERAL SPONSOR



## SPONSORS



## INFOPARTNERS





## PROGRAM COMMITTEE

### *CHAIR:*

**Vadim Kukushkin**, Academician of Russian Academy of Science, Professor,  
St. Petersburg State University

### *VICE CHAIRS:*

**Irina Balova**, Professor, St. Petersburg State University

Chairwoman of the Conference Organizing Committee

**Vladimir Mikhaylov**, Associate Professor, St. Petersburg State University

Scientific Secretary of the Conference

**Rolf Gleiter**, Professor, Heidelberg University, Germany

**Valentin Ananikov**, Academician of Russian Academy of Science,  
Professor, Zelinsky Institute

**Gerd Leuchs**, Professor, Max-Planck-Institut für die Physik des Lichts,  
Germany

**Julien Bachmann**, Professor, Friedrich-Alexander University, Germany

**Dmitry Kirsanov**, Professor, St. Petersburg State University

**Alexander Novikov**, Senior Researcher, St. Petersburg State University

**Dmitrii Bolotin**, Associate Professor, St. Petersburg State University

**Alina Manshina**, Professor, St. Petersburg State University

**Olga Bakulina**, Associate Professor, St. Petersburg State University

**Regina Islamova**, Professor, St. Petersburg State University

**Robert Evarestov**, Professor, St. Petersburg State University

## **ORGANIZING COMMITTEE**

**Mariia Efremova**, Senior Lecturer, St. Petersburg State University

**Maria Dmitrenko**, Associate Professor, St. Petersburg State University

**Alexandra Golikova**, Assistant Professor, St. Petersburg State University

**Ilia Tumkin**, Associate Professor, St. Petersburg State University

**Mikhail Polynski**, Junior research associate, ZIOC RAS, St. Petersburg State University

**Daria Mamonova**, Postdoc, St. Petersburg State University

**Maria Khaidukova**, Senior postdoctoral researcher, FSBSI Institute of Experimental Medicine

**Andrey Kalinichev**, Assistant Professor, St. Petersburg State University

**Artemy Samarov**, Associate Professor, St. Petersburg State University

**Radmila Smirnova**, St. Petersburg State University

**Anna Ivanova**, St. Petersburg State University

**Anna Ketova**, St. Petersburg State University

**Alexandra Sysoeva**, St. Petersburg State University

**Ekaterina Levashova**, St. Petersburg State University

**Mikhail Dobrynyn**, St. Petersburg State University

**Nadezhda Shcherbina**, St. Petersburg State University

**Anastasia Babushkina**, St. Petersburg State University

**Andrey Firsov**, St. Petersburg State University

**Elena Silyavka**, St. Petersburg State University

**Elena Shutova**, St. Petersburg State University



# CONTENTS

PROGRAM COMMITTEE	5
ORGANIZING COMMITTEE	6
SPONSORS	8
PLENARY SPEAKERS	17
KEYNOTE SPEAKERS	30
ANALITICAL CHEMISTRY	46
COMPUTER MODELING AND CHEMINFORMATICS	123
INORGANIC AND ORGANOMETALLIC CHEMISTRY	181
NANOCHEMISTRY AND NANOMATERIALS	365
ORGANIC AND BIOMEDICAL CHEMISTRY	513
POLYMER SCIENCE	692



# **SPONSORS**





Gazprom Neft is a vertically integrated oil company, primarily engaged in the exploration and development of oil and gas fields, oil refining, and the production and sale of petroleum products. Gazprom Neft is one of the Russian oil industry's leading companies in terms of efficiency. Gazprom Neft's largest shareholder is Gazprom PJSC, which holds a 95.68% interest. The remaining shares are in free circulation. Gazprom Neft's corporate structure encompasses more than 70 exploration and production, refining, and retailing enterprises throughout Russia, the CIS and worldwide.

Gazprom Neft's total hydrocarbon reserves (proved+probable — 2P, SPE-PRMS, including production through joint ventures) stood at 3.9 billion tonnes of oil equivalent as at 31 December 2020. The company's reserves life is 22 years. Gazprom Neft is one of Russia's top three companies in terms of hydrocarbon production.

Gazprom Neft operates throughout Russia's major oil and gas regions, including the Khanty-Mansi and Yamalo-Nenets Autonomous Okrugs, the Omsk, Orenburg and Tomsk Oblasts, and the Sakha Republic. In addition to this, the company is also involved in production projects beyond Russia, in Serbia, Iraq, Venezuela, and elsewhere.

The company's objective is to become one of the world's best industrial companies, defining the progressive transformation of the industry, making the impossible real and inspiring its followers in Russia and beyond. The company creates resources for the future, enriching the world with energy, knowledge and technology for confident movement to the better.



Since 2006 **FIZLABPRIBOR** has been a supplier of equipment and consumables for analytical, preparative and industrial liquid chromatography, components for gas and liquid chromatographs, high pressure and catalytic reactors, chemical raw materials, standards and reagents for equipping pharmaceutical and biotechnology production facilities, production and research laboratories, quality control centers. Today **FIZLABPRIBOR** is the leading and exclusive distributor in Russia of well-known European and American, Japanese and South Korean manufacturers.



**Dia-M** company was established in 1988. **Dia-M** supplies laboratory equipment, consumables and reagents for biological, chemical, medical and food laboratories; for science, and productions.

**Dia-M** offers the widest range of goods on the Russian market:

- equipment – for chemistry, biotechnology, analytics and general laboratory practice;
- chemicals – for general laboratory practice, analytics and for biotechnology productions;
- special and general laboratory plastic and glass...

Totally – more than 100,000 items.

Chemical productions and their laboratories takes the particular place in **Dia-M** program.

**Dia-M** is a dealer of the world leading laboratory production companies such as IKA, Merck (Millipore, Sigma-Aldrich-Fluka-Supelco), Mettler Toledo, Ohaus, Bicasa, Eppendorf, PHCbi, Thermo Fisher Scientific, Binder, Buchi, Corning, Heidolph, Olympus, Nikon etc.



GalaChem Company is a reliable supplier of equipment, reagents and consumables for quality control departments and research laboratories. Among company's customers are pharmaceutical companies, small production facilities and research laboratories. Also it is possible to buy a wide choice of reagents, general laboratory instruments and account materials for any tasks.

The company employs highly qualified specialists who are always ready to consult you when choosing equipment and provide competent technical support. GalaChem's reputation is confirmed by a large number of successfully completed orders. The company cooperates with several dozens of suppliers to provide the widest range of reagents and equipment ideally suited for the customers' tasks, for the best prices.

GalaChem's partners are such manufacturers as Merck, Hitachi, InterChim-Advion, IKA, KNF, Waters, Agilent, DWK, Macherey-Nagel, USP, LGC, Isolab and many others.



BIOCAD is one of the largest innovative biotech companies in Russia. It brought together world-class R&D centers, modern pharmaceutical and biotech production, preclinical and clinical, compliant with international standards.

BIOCAD is a full-cycle drug development company, from molecule search to mass production and marketing support. The drugs are intended for the treatment of oncological, autoimmune and other socially significant diseases. Present product portfolio includes 61 medical products, 22 of them are biological. Over 40 products are now in different development stages. Development of drugs for cancer therapy is one of the priorities of the company.

There are 2600 people working in BIOCAD, 1/3 of them are scientists and researchers. Offices of the company are located in Brazil, China, Vietnam and UAE.



The Russian company "AVRORA" has been working on the market of analytical equipment since 1993 and for more than 20 years has been an official exclusive representative and distributor of leading foreign companies-manufacturers of control, measuring, analytical and general laboratory equipment.

AVRORA provides technical consultations to its clients at all stages of cooperation when working on equipment deliveries. The company's service center "AVRORA SERVICE" has specialists of the highest qualification who are regularly trained at foreign manufacturers.



For 80 years, BUCHI has been a leading solution provider in laboratory technology for R&D, quality control and production worldwide. The company is headquartered in Eastern Switzerland and has R&D, production, sales and service facilities around the world.

What started as a craftsman's workshop over 80 years ago has grown into a global glass, mechatronics, and technology company offering fully automated laboratory technology solutions, proprietary software, and application expertise. BUCHI's high-quality laboratory instruments are manufactured to exacting standards using streamlined processes.

BUCHI strives to develop intuitive and versatile products and solutions that are robust, intelligently designed, and exceed the customers' expectations. Each of the company's products complies with its guiding philosophy of «Quality in your hands».



WERTEKS Pharmaceutical Company was founded in 1999 in St. Petersburg. In 2003 it launched production. Since 2020 the company is included in the list of strategic enterprises of St. Petersburg and Russia.

WERTEKS ranks first among pharmacies in Russia: by market share among Russian pharmaceutical producers of antibiotics for antibiotic therapy against COVID-19 (in value terms; source - AlphaRM, Q1-Q3 2020), as well as by sales growth in the top 20 pharmaceutical producers in Russia in 2020. (source - DSM Group).

The company offers about 320 product lines in the portfolio, of which about 240 are drugs; the remaining products are cosmetics, dietary supplements of own brands. More than 65 thousand pharmacies with the company's products are located in Russia, as well as in Belarus, Kazakhstan, Kyrgyzstan, Mongolia, Tajikistan, Armenia, Georgia, Uzbekistan.

Besides a wide assortment of drugs (branded and generic INN), cosmetics and dietary supplements WERTEKS produces original combined drugs for use in gynecology, dermatology, cardiology, otorhinolaryngology, treatment of symptoms of respiratory diseases and flu. They have no analogues on the Russian market.



1. Scientific and production company BARS-2 has been successfully operating on the Russian market since 1992.

For 29 years the company has been working strenuously to demonstrate rapid and professional development, as well as to take the leading position in the industry.

BARS-2 occupies a quarter on the Russian market of masterbatches for coloring and modification of thermoplastic polymers.

2. Today BARS-2 has several production plants in Russia and regional representative offices with their own warehouses located in all federal districts, as well as an extensive dealer network in Russia, CIS and Baltic countries.

More than 3,000 companies consume a wide range of masterbatches under the BASCO® trade mark.

Positive results of the company's operation on the market has been achieved owing to responsibility to consumers, risk analysis and risk mitigation measures, interaction with suppliers.

3. The company constantly monitors new discoveries, optimizes processes, and uses advanced equipment. Highly qualified technical specialists of BARS-2 develop innovative products according to market requirements.

The equipment of BARS-2 R&D Center allows to design and model almost all the main polymer processing types. Such approach makes it possible to efficiently and accurately control the quality of produced masterbatches and develop new products.

4. BARS-2 implements customer-oriented policy. This includes prompt response, safeguarding the interests of customers, and technical service. BARS-2 is willing and able to find mutual understanding and common ground with customers.

5. The team of BARS-2 company makes every effort for joint growth and mutually beneficial business development with partners.



G-RISC is the German-Russian Interdisciplinary Science Center. It is a Center of Excellence, which is funded by the German Academic Exchange Service (DAAD).

G-RISC is a multidisciplinary platform for modern research and education. It covers important areas of natural sciences with emphasis on fundamental and applied research, environmental sciences, life sciences, materials research, as well as the structure and dynamics of matter.

G-RISC brings together the key competences from leading universities and research laboratories from Russia and Germany. The breadth of the scope of G-RISC underlines a modern interdisciplinary concept of research and education.



EuroChem is a global producer of commodity and specialty fertilizers. It is a fertilizer manufacturer with its own capacity in all three primary nutrients – nitrogen, phosphates and potash.

It is headquartered in Zug, Switzerland. EuroChem has manufacturing, logistic and distributing facilities in Russia, Belgium, Lithuania, Brazil, China, Kazakhstan, Estonia, Germany and the USA.

The company's production facilities are located in Russia, Belgium, Lithuania and China. It has mining activities in Kovdor, Murmansk Oblast, Russia, Usolye, Perm Krai, Russia, Kotelnikovo, Volgograd Oblast, Russia, and Zhambyl Province, Kazakhstan.

According to the company, it is one of the world's top-5 leading producers of nitrogen, phosphate, potash and complex fertilizers.



ChemConsult provides a full range of chemical services for the development and selection of active pharmaceutical ingredients, optimization of the selected target molecules using unique experience in medicinal chemistry.

ChemConsult performs API synthesis in the required quantities for in vitro and in vivo testing, optimization of technologies for large-scale production.



BIKASARU was founded in 2017 in St. Petersburg and is the official representative of BICASA ITALY, a highly intelligent engineering company in the field of laboratory design.

Today BIKASARU, has an engineering team, a service center, additional sales offices in St. Petersburg and Moscow and a wide regional dealer network, occupies a leading position of engineering companies in the market of Russia and the CIS countries





# **PLENARY SPEAKERS**



## **Prof. Peter Lieberzeit**

*Full Professor and Head of the Department of Physical Chemistry,  
University of Vienna, Vienna, Austria*

### **Short CV**

1991-1996 MSc in Chemistry at the University of Vienna, graduated with distinction  
1996-1999 PhD in Chemistry @UNIVIE, graduated with distinction  
2007 "Habilitation" ("Post-doctoral Lecture Qualification" in Analytical Chemistry)  
1997-2007: Research Assistant at the Department of Analytical Chemistry of the University of Vienna  
2007-2011: Associate Professor  
Since October 2011: Full Professor. Since Feb. 2016 at the Department of Physical Chemistry  
Since October 2014: President of Studies Legislations and Affairs at UNIVIE

More than 140 papers indexed in Web of Science (h=30) and roughly 180 conference contributions.  
Wolfgang Goepel Award at ISOEN 2007 in St Petersburg.

2011 Fritz Feigl Award of the Austrian Society for Analytical Chemistry (ASAC).

Since 2018 Member of the Editorial Board of Sensors and Actuators B (IF=7.1).

General Chair of the 17th International Meeting on Chemical Sensors (IMCS2018) in Vienna.

Since 2018 Chairman of the International Scientific Committee of the IMCS conference series.

Member of the Editorial Advisory Boards of Analytical and Bioanalytical Chemistry (IF=3.3) and Monatshefte für Chemie/Chemical Monthly (IF=1.34).

### **Scientific interests**

Developing highly selective, artificial recognition materials based on polymers and biomimetics.

### **Key publications**

1. Chunta, S.; Suedee, R.; Singsanan, S.; Lieberzeit, P.A. Sensing array based on molecularly imprinted polymers for simultaneous assessment of lipoproteins. *Sensors Actuators, B Chem.* 2019, 298, 126828, doi:10.1016/j.snb.2019.126828.

2. Van Ho Phan, N.; Sussitz, H.F.; Ladenhauf, E.; Pum, D.; Lieberzeit, P.A. Combined layer/particle approaches in surface molecular imprinting of proteins: Signal enhancement and competition. *Sensors (Switzerland)* 2018, 18, doi:10.3390/s18010180.

3. Naklua, W.; Suedee, R.; Lieberzeit, P.A. Dopaminergic receptor-ligand binding assays based on molecularly imprinted polymers on quartz crystal microbalance sensors. *Biosens. Bioelectron.* 2016, 81, 117–124, doi:10.1016/j.bios.2016.02.047.

### **Website**

<https://pchem.univie.ac.at/en/research-groups/chemical-sensing-and-rapid-analysis/>

## MOLECULARLY IMPRINTED POLYMERS IN RAPID ANALYSIS: CHANCES AND CHALLENGES

*Lieberzeit P.A.*<sup>1</sup>, *Unger C.*<sup>1</sup>, *Bräuer B.*<sup>1</sup>, *Sudjarwo W.A.*<sup>1</sup>, *Alzahrani S.*<sup>1</sup>, *Werner M.*<sup>1</sup>, *Glueck M.*<sup>1</sup>

<sup>1</sup>University of Vienna, Faculty for Chemistry, Department of Physical Chemistry, Vienna, Austria

[Peter.Lieberzeit@univie.ac.at](mailto:Peter.Lieberzeit@univie.ac.at)

Molecular imprinting of polymers has been developed for sensing purposes since the mid-1980s [1] and has since then attracted substantial scientific attention, because it offers features that make it highly promising for inherently mass-producible sensors: the resulting molecularly imprinted polymers (MIPs) offer recognition properties that match those of natural antibodies [2]. However, consisting of artificial materials, they are more rugged, easy-to use and suitable for sensing in non-physiological environments. Despite the huge body of scientific work published, however, only very limited MIP-based sensors have found their way a bit closer to actual application. When sensing biological species, for instance, there are quite few papers showing actual real-life application [3]. Among others, the reasons for this are lack of detailed understanding of the physicochemical processes taking place on the polymer surface and distribution of binding site affinities there [4].

For instance, in the case of surface imprints for micro-organisms, the response behavior of the final sensor does not only depend on polymer composition, but also on pH and salinity of the medium used for that purpose: the former influences the zeta potentials of the surfaces involved. The latter may interact with the transducer and thus lead to (sometimes unexpected) background signals. Gaining further understanding of the binding processes becomes increasingly possible by utilizing surface mapping techniques, such as Raman Microscopy combined with atomic force microscopy. This allows not only for distinguishing different bacteria species present on surfaces, including those of molecularly imprinted polymers, but also between the polymer surface, imprints, and cavities. Furthermore, high-resolution AFM allows for elucidating washing and rebinding processes of such polymers in detail.

To address the second aspect – distribution of binding site affinities – the group of S. Piletsky in Leicester has pioneered a solid-phase synthesis approach [5]. The main idea there is to synthesize so-called “nanoMIP” or “MIP nanobodies”, i.e. particles that contain only a single, high-affinity binding site on their surfaces. This allows for implementing them into assay formats, where they can in principle replace natural antibodies and thus reduce assay costs substantially. In the case of using mass-sensitive transducers, such as the quartz crystal microbalance (QCM), this for instance leads to in-situ read-out of both direct and competitive assays for different proteins, such as human serum albumin (HSA) or insulin. Both fluorescence data and mass-sensitive sensor characteristics indicate high-affinity binding between the nanoparticles and their respective target. This leads to appreciable recovery rates (around 100%) even in the presence of interfering compounds and in complex matrices, such as artificial urine.

### References

- [1] Leibl N., Haupt K., Gonzato C., Duma L., *Chemosensors* **2021**, 9, 123
- [2] Schirhagl R., Lieberzeit P.A., Dickert F.L., *Adv. Mater.* **2010**, 22, 2078-2081.
- [3] Braeuer B., Unger C., Werner M., Lieberzeit P.A., *Sensors* **2021**, 21, accepted.
- [4] Unger C., Lieberzeit P.A., *React. Funct. Polym.* **2021**, 161, 104855.
- [5] Refaat D., Aggour M.G., Farghali, A.A., Mahajan R., Wiklander J.G., Nicholls I.A., Piletsky S.A., *Int. J. Mol. Sci.* **2019**, 20, 6304.



## **Dr. Timur Madzhidov**

*Senior Researcher, Chemoinformatics and Molecular Modelling Lab;  
Associate Professor, Chair of Organic Chemistry, A.M. Butlerov  
Institute of Chemistry, Kazan Federal University, Kazan, Russia*

### **Short CV**

Graduated from Kazan State University in 2007. Defended Ph.D. thesis in Organic Chemistry in 2011. From 2011 to 2013 worked as post-doc in Chemoinformatics Lab, University of Strasbourg, France.

Invited Researcher in Chemoinformatics Lab, University of Strasbourg, about 1-2 months a year since 2014.

One of founders and authors of Master Program in Chemoinformatics and Molecular Modelling in Kazan Federal University, the first educational program in chemoinformatics in Russia. The Program got double-diploma status with University of Strasbourg in 2013 and international validation in 2015. Author of textbook "Introduction to chemoinformatics". Leading research in chemical reaction mining, applications of artificial intelligence in chemistry, drug and polymer design. Member of Early Career Advisory Board members of journal "Mendeleev Communications".

### **Scientific interests**

Chemoinformatics, artificial intelligence in chemistry, reaction informatics, materials informatics, quantum chemistry, theory of atoms in molecules, digitalization of chemistry.

### **Key publications**

1. Lodochnikova, O.A.; Latypova, L.Z.; Madzhidov, T.I.; Chmutova, G.A.; Voronina, J.K.; Gubaidullin, A.T.; Kurbangalieva, A.R. "Lp $\pi$ synthon" interaction as a reason for the strong amplification of synthon-forming hydrogen bonds. *CrystEngComm* 2019, 21, 1499–1511, doi:10.1039/c8ce01982g.
2. Kutlushina, A.; Khakimova, A.; Madzhidov, T.; Polishchuk, P. Ligand-based pharmacophore modeling using novel 3D pharmacophore signatures. *Molecules* 2018, 23, 1–14, doi:10.3390/molecules23123094.
3. Baskin, I.I.; Madzhidov, T.I.; Antipin, I.S.; Varnek, A.A. Artificial intelligence in synthetic chemistry: achievements and prospects. *Russ. Chem. Rev.* 2017, 86, 1127–1156, doi:10.1070/rcr4746.

### **Website**

[https://kpfu.ru/Timur.Madzhidov?p\\_lang=2](https://kpfu.ru/Timur.Madzhidov?p_lang=2)

## ARTIFICIAL INTELLIGENCE IN SYNTHETIC CHEMISTRY: COMPUTER MEETS SYNTHESIS

Madzhidov T.I.<sup>1</sup>, Nugmanov R.I.<sup>1</sup>, Afonina V.A.<sup>1</sup>, Fatykhova A.A.<sup>1</sup>, Rakhimbekova A.<sup>1</sup>, Baskin I.I.<sup>2</sup>, Antipin I.S.<sup>1</sup>, Varnek A.<sup>3</sup>

<sup>1</sup>Kazan Federal University, Kazan, Russia

<sup>2</sup>Technion, Haifa, Israel

<sup>3</sup>University of Strasbourg, Strasbourg, France

[timur.madzhidov@kpfu.ru](mailto:timur.madzhidov@kpfu.ru)

Wealth of data on chemical compounds and organic reaction has been collected due to increasing performance of synthetic work. The greatest databases contain about 100 mln data on chemical reactions. It opened the door for applications of big data analytics and data mining technologies (including artificial intelligence approaches) in synthetic chemistry [1].

We will review some most important and interesting applications that artificial intelligence has found in synthetic chemistry. We will describe how synthetic plan leading to desired compound can be deduced using computational retrosynthesis or alternative approaches. Approaches for synthetic *de novo* design (e.g. design of compound with desired property) will be specially described. Moreover, utility of artificial intelligence to propose new chemical reactions will be demonstrated.

Having synthesis plan, one wants to know how performant is the particular reaction and select conditions that lead to desired product. We will give an overview of AI-based computational approaches for assessing reaction kinetics, thermodynamics, yield and optimal reaction condition. Especially we will focus on approaches that can be used for analysis of reaction space to extract important information on chemical reactivity based on bunch of data. We will show what's wrong with Markovnikov rule and how its problems can be avoided.

And finally, we will give a brief review of the first steps of chemical robotics, discuss the most important types of intelligent chemical robots and the applications were designed for.

### References

[1] Baskin I.I., Madzhidov T.I., Antipin I.S., Varnek A. Russ. Chem. Rev. 2017, 86, 1127.

Acknowledgements. This work was supported by the Russian Science Foundation (project No 19-73-10137).



## **Prof. Yulia Gorbunova**

*Corresponding Member RAS, Professor, Institute of General and Inorganic Chemistry N.S. Kurnakov Russian Academy of Sciences, Moscow, Russia*

### **Short CV**

*Educational background (degrees, dates, universities):*

M.Sc., 1990, Lomonosov Moscow State University, Chemical department  
Ph.D., 1995, Institute of General and Inorganic Chemistry Russian Academy of Sciences (IGIC RAS)  
Dr.Habil., 2006, Institute of General and Inorganic Chemistry Russian Academy of Sciences (IGIC RAS)  
Professor, 2013  
Corresponding member of Russian Academy of Sciences, 2016

*Career/Employment (employers, positions and dates):*

Kurnakov Institute of General and Inorganic Chemistry Russian Academy of Sciences, main researcher, 1993 – ongoing  
Frumkin Institute of Physical Chemistry Russian Academy of Sciences, main researcher, 2002- ongoing  
Vice-President of Mendeleev Russian Chemical Society, 2016-ongoing  
Institute of Organic Semiproducts and Dyes, post-graduate student, 1990-1993

### **Publications**

Number of papers in refereed journals – 250 (H-index 28; >2600 times cited)  
Number of oral presentations in scientific meetings – 216

### **Awards**

Award of European Academy of Science for young researcher, 2001  
Russian Government prize in the field of science and techniques, 2002  
L.A. Chugaev Award in coordination chemistry (Russian Academy of Sciences), 2010  
Chevalier dans l'Ordre national des Palmes Academiques, Government of France, 2016

### **Scientific interests**

Coordination chemistry, Supramolecular chemistry, Phthalocyanines, Porphyrins, Rare-earth elements, Spectroscopy, Platinum metals

### **Key publications**

1. Lapkina L.A., Larchenko V.E., Kirakosyan G.A., Tsivadze A.Yu., Troyanov S.I. and Gorbunova Yu.G. Cation-Induced Dimerization of Crown-Substituted Phthalocyanines by Complexation with Rubidium Nicotinate As Revealed by X-ray Structural Data. *Inorg. Chem.* 57, 82–85 (2018).
2. Martynov A.G., Safonova E.A., Tsivadze A.Y., Gorbunova Y.G.// Functional Molecular Switches Involving Tetrapyrrolic Macrocycles. *Coord. Chem. Rev.* 387, 325–347 (2019).
3. Abdulaeva I.A., Birin K.P., Bessmertnykh-Lemeune A., Tsivadze A. Yu., Gorbunova Yu.G. Heterocycle-appended porphyrins: synthesis and challenges. *Coord.Chem.Rev.* 407, 213108 (2020).

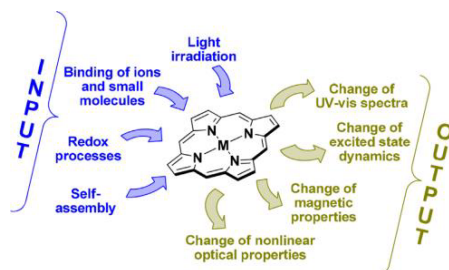
<sup>1</sup>N.S. Kurnakov Institute of general and inorganic chemistry RAS, Leninsky prosp. 31, Moscow, 119991, Russia<sup>2</sup>A.N. Frumkin Institute of physical chemistry and electrochemistry RAS,  
Leninsky prosp. 31, bldg. 4, Moscow, 119071, Russia

Main researcher

[Yulia.gorbunova@gmail.ru](mailto:Yulia.gorbunova@gmail.ru)

Functional properties of macrocyclic tetrapyrrolic ligands are widely exploited in natural and artificial systems. The molecular structure of free base porphyrins and their complexes can be precisely adapted to the target function and the operating environment by varying the substituents on the macrocycle. Another tool widely used by Nature to increase the functional performance of tetrapyrroles is the coordination and supramolecular chemistry approaches. Such approaches lead to wide range of application of synthetic porphyrinoids.

From the other side, the possibility to control and tune the properties of a single molecule attracts scientists from ancient times to our days. This is well confirmed by the Nobel Prize in Chemistry in 2016 that was awarded jointly to Jean-Pierre Sauvage, Sir J. Fraser Stoddart and Bernard L. Feringa "For the design and synthesis of molecular machines". High sensitivity of physical-chemical properties of porphyrinoids to external influence paved them the way to the area of molecular switches with various types of actions. From this viewpoint, porphyrinoids can be regarded as information processing systems, which convert input physical-chemical data into output signals (Figure) [1].



This report is summarized the recent results on the synthetic and material chemistry of tetrapyrrolic compounds including the results of our scientific group [2-20].

### References

- [1] Martynov, A.G., Safonova, E.A., Tsivadze, A.Y., Gorbunova, Y.G. *Coord. Chem. Rev.*, **2019**, *387*, 325-347.
- [2] Enakieva Yu.Yu., Sinelshchikova A.A., Grigoriev M.S., et al. *Chem. A Eur. J.*, **2019**, *25*, 10552-10556.
- [3] Martynov, A.G., Mack, J., May, A., et al. *ACS Omega*, **2019**, *4*, 7265-7284.
- [4] Rozhkov A.V., Krykova M.A., Ivanov D.M., et al. *Angew. Chem.*, **2019**, *58*, 4164-4168.
- [5] Shekunova T.O., Lapkina L.A., Shcherbakov A.B., et al. *J. Photochem. Photobiol. A*, **2019**, *382*, 111925.
- [6] Jiménez-Munguía I., Fedorov A.K., Abdulaeva I.A., et al. *Biomolecules*, **2019**, *9*, 853.
- [7] Konarev, D.V., Khasanov, S.S., Batov, M.S. et al. *Inorg. Chem.*, **2019**, *58*, 5058-5068.
- [8] Zairov, R.R., Khrizanforov, M., Nizameev, I.R. et al. *J. of Nanopart. Res.*, **2019**, *21*, art.12.
- [9] Otvagin V.F., Kuzmina N.S., Krylova L.V., et al. *J. of Medic. Chem.*, **2019**, *62*, 24, 11182-11193.
- [10] Martynov A.G., Polovkova M.A., Berezhnoy G.S. et al. *Inorg. Chem.*, **2020**, *59*, 9424–9433.
- [11] Abdulaeva I.A., Birin K.P., Bessmertnykh-Lemeune A., et al. *Coord.Chem.Rev.*, **2020**, *407*, 213108.
- [12] Shokurov A. V., Kutsybala D. S., Martynov A. G., et al. *Langmuir*, **2020**, *36*, 1423–1429.
- [13] Yagodin A.V., Martynov A.G., Gorbunova Yu.G., Tsivadze A.Yu. *Dyes&Pig.*, **2020**, *181*, art. 108564.
- [14] Kolesnikov I.E., Kurochkin M.A., Meshkov I.N. et al. *Materials and Design*, **2021**, *203*, 109613.
- [15] Enakieva Yu.Yu., Sinelshchikova A.A., Grigoriev M.S. et al. *Chem. – A Eur.J.*, **2021**, *27*, 1598 – 1602.
- [16] Lapkina L.A., Sinelshchikova A.A., Birin K.P., et al. *Inorg. Chem.*, **2021**, *60*, 1948-1956.
- [17] Cailler L.P., Kroitor A.P., Martynov A.G., et al. *Dalton Trans.*, **2021**, *50*, 2023 – 2031.
- [18] Enakieva Yu.Yu., Zhigileva E.A., Fitch A.N., et al. *Dalton Trans.*, **2021**, *50*, 6549-6560.
- [19] Martynov, A.G., Polovkova M.A., Berezhnoy G.S., et al. *Inorg. Chem.*, **2021**, *60*, 9110-9121.
- [20] Babailov S.P., Polovkova M.A., Kirakosyan G.A. et al. *Sensors and Actuat. A: Phys.* **2021**, art. 112933

Acknowledgements. This work was supported by the Russian Science Foundation (project No 19-13-00410).



## **Prof. Karl Mandel**

*Professor for Inorganic Chemistry, Friedrich-Alexander University of Erlangen-Nürnberg, Germany and Head of Particle Technology, Fraunhofer ISC, Germany*

### **Short CV**

Karl Mandel studied Earth Sciences and Materials Science in Munich (Germany), Ulm (Germany) and Oxford (UK) (2005-2010) and holds a PhD in Chemistry (graduated 2013, Würzburg, Germany). Since 2014 he heads the Particle Technology Group at the Fraunhofer Institute for Silicate Research (ISC) in Würzburg (Germany). In 2020 he was appointed as Professor for Inorganic Chemistry at the Friedrich-Alexander University Erlangen-Nürnberg (Germany)

### **Scientific interests**

We assemble complex particles, so-called supraparticles, from nano building blocks.

We study how the supraparticle's structure and complex composition determines unique functionalities. With these supraparticles, we aim at creating smart materials in the field of sustainability

### **Key publications**

1. Seuffert, M.T.; Wintzheimer, S.; Oppmann, M.; Granath, T.; Prieschl, J.; Alrefai, A.; Holdt, H.-J.; Müller-Buschbaum, K.; Mandel, K. An all white magnet by combination of electronic properties of a white light emitting MOF with strong magnetic particle systems. *J. Mater. Chem. C* 2020, 8, 16010–16017, doi:10.1039/d0tc03473h.
2. Müssig, S.; Fidler, F.; Haddad, D.; Hiller, K.H.; Wintzheimer, S.; Mandel, K. Supraparticles with a Magnetic Fingerprint Readable by Magnetic Particle Spectroscopy: An Alternative beyond Optical Tracers. *Adv. Mater. Technol.* 2019, 4, 1–6, doi:10.1002/admt.201900300.
3. Wintzheimer, S.; Granath, T.; Oppmann, M.; Kister, T.; Thai, T.; Kraus, T.; Vogel, N.; Mandel, K. Supraparticles: Functionality from Uniform Structural Motifs. *ACS Nano* 2018, 12, 5093–5120, doi:10.1021/acsnano.8b00873

### **Website**

<https://www.chemistry.nat.fau.eu/mandel-group/>



NANO 2.0: SUPRAPARTICLES  
- AND HOW THESE MAKE MATERIALS SMART AND CONTRIBUTE TO SUSTAINABILITY

Mandel K.

Friedrich-Alexander University Erlangen-Nürnberg (FAU), Germany

Nanoparticles can be engineered nowadays in all kinds of compositions, morphologies, and different sizes. In analogy to supramolecular chemistry, I consider it as the next step in nanoscience and technology to start using these nanoparticles as building blocks for more complex entities. These might be termed supraparticles. In the first part of this talk, the concept and definition of supraparticles will be introduced.

In the second part of the talk, examples from our labs for such supraparticle systems will be given in application fields that contribute to sustainability. To justify a contribution to sustainability, I make an initial attempt to define the meaning of "sustainability" from a natural science point of view, based on the fundamental laws of thermodynamics.



### References

- [1] Wintzheimer S., Reichstein J., Groppe P., Wolf A., Fett B., Zhou H., Pujales Parabela R., Miller F., Müssig S., Wenderoth S., Mandel K., Supraparticles for Sustainability, *Advanced Functional Materials* (2021), DOI: 10.1002/adfm.202011089
- [2] Wintzheimer S., Granath T., Oppmann M., Kister T., Thai T., Kraus T., Vogel N., Mandel K., Supraparticles: Functionality from Uniform Structural Motifs, *ACS nano* 12 (2018), p. 5093-5120  
DOI: 10.1021/acsnano.8b00873



## **Prof. Igor Alabugin**

*Full Professor, Florida State University, Tallahassee, USA*

### **Short CV**

Igor V. Alabugin (born in 1969) is a Professor at Florida State University since 2010. He earned his BSc/MSc degrees from Moscow State University in 1991 and obtained his PhD from the same University in 1995. After working in 1996-2000 as Postdoctoral Research Associate at University of Wisconsin-Madison (with Prof. Howard E. Zimmerman) he joined Florida State University as a faculty member in 2000 and served as Assistant and Associate Professor until becoming a Full Professor in 2010. Prof. Alabugin coauthored more than 200 publications (h-index 49, >7000 times cited) and authored the book "Stereo-electronic Effects: the Bridge between Structure and Reactivity (Wiley, 2016).

Among his awards are the Fulbright Scholar Award – Distinguished Chair, FSU Cottrell Professorship, Fellow of the American Association for the Advancement of Science, Top Reviewer (for RSC Chemical Science, Angewandte Chemie, RSC Organic Chemistry Frontiers), The 2019 Favorsky Lecturer (St. Petersburg University). He was an invited, plenary or a keynote speaker at many international conferences (gave more than 180 lectures).

### **Scientific interests**

The research of Prof. Alabugin's group focuses on the structure and reactivity of organic compounds, especially chemistry of alkynes. Prof. Alabugin is widely recognized for developing reagents for selective DNA breakdown in cancer cells, functionalization of nanomaterials, the synthesis of graphene structures, as well as fundamental research of stereo-electronic effects and alkyne reactivity

### **Key publications**

1. Gonzalez-Rodriguez, E.; Abdo, M.A.; Dos Passos Gomes, G.; Ayad, S.; White, F.D.; Tsvetkov, N.P.; Hanson, K.; Alabugin, I. V. Twofold  $\pi$ -Extension of Polyarenes via Double and Triple Radical Alkyne peri-Annulations: Radical Cascades Converging on the Same Aromatic Core. *J. Am. Chem. Soc.* 2020, 142, 8352–8366, doi:10.1021/jacs.0c01856.
2. Zhou, Z.; Kawade, R.K.; Wei, Z.; Kuriakose, F.; Üngör, Ö.; Jo, M.; Shatruk, M.; Gershoni-Poranne, R.; Petrukhina, M.A.; Alabugin, I. V. Negative Charge as a Lens for Concentrating Antiaromaticity: Using a Pentagonal "Defect" and Helicene Strain for Cyclizations. *Angew. Chemie - Int. Ed.* 2020, 59, 1256–1262, doi:10.1002/anie.201911319.
3. Tsvetkov, N.P.; Gonzalez-Rodriguez, E.; Hughes, A.; dos Passos Gomes, G.; White, F.D.; Kuriakose, F.; Alabugin, I. V. Radical Alkyne peri-Annulation Reactions for the Synthesis of Functionalized Phenalenes,

### **Website**

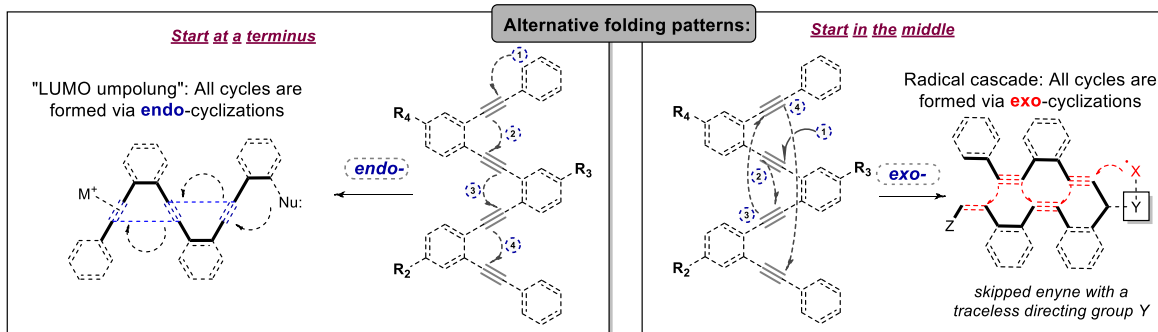
<https://www.chem.fsu.edu/~alabugin/>

FROM ALKYNE ORIGAMI TO ELECTRON UPCONVERSION: RADICAL APPROACHES TO NEW POLYAROMATICS

*Alabugin I.V.*

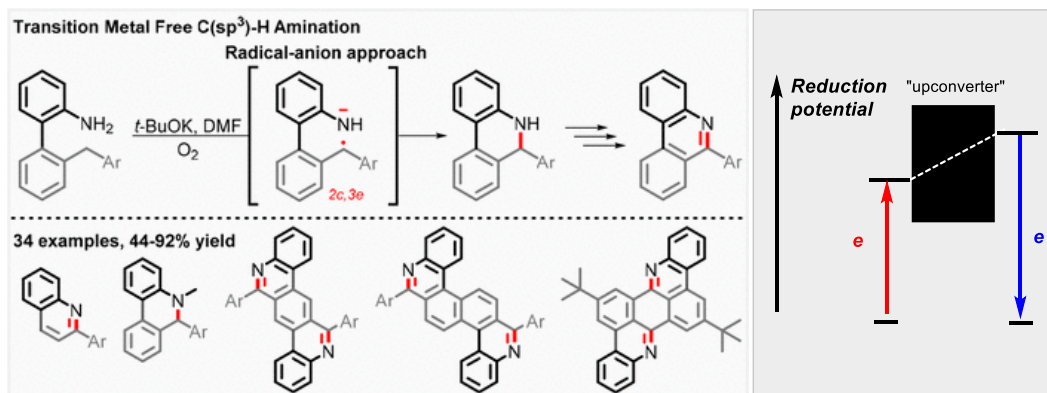
Florida State University, Tallahassee, Florida, USA  
[ialabugin@fsu.edu](mailto:ialabugin@fsu.edu)

In the 1st part, I will discuss the advantages of alkynes as high-energy carbon-rich precursors for extended polyaromatics, the two general patterns of oligoalkyne folding into an aromatic ribbon, and the use of supramolecular effects in the design of traceless directing groups for radical reactions.[1]



**Figure 1.** Examples of “alkyne origami” for preparation of polyaromatics.

In the 2nd part, I will present a mild method for C(sp<sup>3</sup>)–H amination from unprotected anilines and C(sp<sup>3</sup>)–H bonds. In this process, basic, radical, and oxidizing species work together in a coordinated sequence of deprotonation, H-atom transfer and electron transfer that forges a new C–N bond.[2] I will also use this cascade transformation to illustrate how reductant upconversion, a new concept in catalysis, can be used for preventing the premature activation of oxidants.[3]



**Figure 2.** Left: An example of radical anionic C–H amination. Right: The concept of electron upconversion

**References**

- [1] I. V. Alabugin, E. Gonzalez-Rodriguez. *Acc. Chem. Res.*, **2018**, *51*, 1206. E. Gonzalez-Rodriguez, M. A. Abdo, G. dos Passos Gomes, S. Ayad, F. D. White, N. P. Tsvetkov, K. Hanson, I. V. Alabugin, *J. Am. Chem. Soc.* **2020**, *142*, 8352–8366. R. K. Kawade, C. Hu, N. R. Dos Santos, N. Watson, X. Lin, K. Hanson, I. V. Alabugin. *Angew. Chem. Int. Ed.*, **2020**, *59*, 14352-14357. Z. Zhou, R. K. Kawade, Z. Wei, F. Kuriakose, R. Gershoni-Poranne, M. A. Petrukhina, I. V. Alabugin, *Angew. Chem. Int. Ed.*, **2020**, *59*, 1256-1262.  
 [2] C. J. Evoniuk, G. d. P. Gomes, S. P. Hill, F. Satoshi, K. Hanson, I. V. Alabugin, *J. Amer. Chem. Soc.*, **2017**, *139*, 16210. Q. Elliott, G. Gomes, C. J. Evoniuk, I. V. Alabugin, *Chem. Science*, **2020**, *11*, 6539 – 6555.  
 [3] Upconversion of Reductants. M. A. Syroeshkin, F. Kuriakose, E. A. Saverina, V. A. Timofeeva, M. P. Egorov, I. V. Alabugin. *Angew. Chem. Int. Ed.*, **2019**, *58*, 5532.

Acknowledgements. This work was supported by the National Science Foundation (CHE-1800329 and CHE-2102579).



## **Prof. Eugenia Kumacheva**

*Professor of Chemistry, Department of Chemistry, University of Toronto, Toronto, Canada*

### **Short CV**

#### *Education:*

1978 — graduated with honors from the St. Petersburg State Technological Institute

1986 — obtained PhD degree in physical chemistry of polymers in the Russian Academy of Sciences

#### *Career and Research:*

1991–1994 — a postdoctoral fellow in the laboratory of Professor Jacob Klein at the Weizmann Institute of Science (Israel)

1995 — joined the group of Professor Mitchel Winnik in the Department of Chemistry at the University of Toronto

1996 — joined the Department of Chemistry at the University of Toronto as an Assistant Professor 2005 — became a Full Professor

#### *Honors and Memberships:*

2003 — Schlumberger Scholarship (Oxford University, UK)

2005 — Macromolecular Science and Engineering Award, CIC

2008 — L'Oréal-UNESCO "Women in Science" Prize (Laurate for North America)

2012 — Humboldt Research Award, Alexander von Humboldt Foundation, Germany

2016 — Elected as Fellow of the Royal Society (FRS) (British National Academy of Science)

2017 — Canada Institute of Chemistry (CIC) Medal

2019 — De Gennes Prize (Royal Society of Chemistry)

### **Scientific Experience**

- Polymer Science
- Nanoscience
- Microfluidics
- Polymers in biological systems

### **Key publications**

1. Yi, C. et al. Self-Limiting Directional Nanoparticle Bonding Governed by Reaction Stoichiometry. *Science* 369, 1369–1374 (2020).

2. Galati, E. et al. Helicoidal Patterning of Nanorods with Polymer Ligands. *Angew. Chem. Int. Ed.* 58, 3123–3127 (2019).

3. Choueiri, R.M. et al. Surface Patterning of Nanoparticles with Polymer Patches. *Nature* 538, 79–83 (2016).

### **Website**

[https://sites.chem.utoronto.ca/chemistry/staff/EK/Eugenia\\_Kumacheva.htm](https://sites.chem.utoronto.ca/chemistry/staff/EK/Eugenia_Kumacheva.htm)

# FROM COLLOIDAL MOLECULES TO NANO-POLYMERS: LESSONS FROM POLYMER CHEMISTRY AND PHYSICS

Kumacheva E.<sup>1,2</sup>

<sup>1</sup>University of Toronto, Toronto, Canada

<sup>2</sup>ITMO University, Saint Petersburg, Russia

[eugenia.kumacheva@utoronto.ca](mailto:eugenia.kumacheva@utoronto.ca)

The concept of “colloidal molecules” builds on the analogy between colloidal particles and molecules. For about a hundred years, colloidal particles have been used to model the behavior of atoms or molecules. Recently, this approach has been reversed: reactions between molecules are now being utilized to model self-organization of inorganic nanoparticles (NPs). In particular, polymer science offers unique strategies to address the challenges in NP assembly.

By using lessons of polymer physics and chemistry, we are developing new paradigms for NP patterning and self-assembly. For NPs end-capped with polymer molecules in a brush-type configuration, we found a striking similarity between NP self-assembly and reaction-controlled step-growth polymerization [1-3]. The kinetics and statistics of polymerization enables a quantitative prediction of the architecture of linear, branched, and cyclic NP chains and their aggregation numbers, as well as the formation of isomers, all in agreement with theory. By using a polymer paradigm, we show the ability to control the aggregation numbers in NP clusters and the strategy for the co-assembly of plasmonic NPs with different dimensions and compositions [4].

In another strategy, we solved a challenging task of NP surface patterning by utilizing thermodynamically driven segregation of polymer ligands into surface-pinned micelles, the process driven by a balance between the interfacial energy of the polymers and the free energy of stretching of the micellar ‘legs’.<sup>4</sup> We achieved control of the dimensions of pinned micelles, their spatial distribution and the number of micelles per nanoparticle, all in agreement with a theoretical model. Our very recent work shows that a stoichiometric acid-base neutralization reaction between reactive brush-type polymer ligands governs self-limiting NP assembly into molecule-type clusters with precisely controlled symmetries.<sup>[5]</sup>

This work bridges the gap between chemical reactions taking place at a molecular level and NP assembly occurring at the length scale three orders of magnitude larger. It shows that the theoretical models developed for molecules can be applied to the fabrication of nanomaterials with new architectures. On the other hand, the ability to monitor NP self-assembly by imaging emerging nanostructures provides a unique way to test theoretical models developed for polymerization. Since programmable NP organization remains a major challenge, polymer-inspired self-assembly strategies have profound implications for the design of nanomaterials with applications in electronics, optics, catalysis, and chemical sensing.



**Figure 1.** Transmission electron microscopy image of linear nano-polymer chains self-assembled from gold nanorods end-terminated with polystyrene molecules

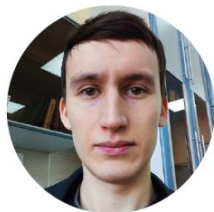
## References

- [1] Liu, K. et al. *Science* **2010**, 329, 197-200
- [2] Klinkova, A. et al. *Proc. Nat. Acad. Sci. U.S.A.* **2013**, 110, 18775-18779
- [3] Liu, K. et al. *Angew. Chem. Intern. Ed.* **2016**, 53, 2648-2653
- [4] Yi, C. et al. *Science* **2020**, 369, 1369-1374.
- [5] Choueiri, R. M. et al. *Nature* **2016**, 538, 79-83

**Acknowledgements.** This work was supported by NSERC CANADA [Canada Research Chair and Discovery programs).



# **KEYNOTE SPEAKERS**



## **Dr. Yuri Kuzin**

*Research fellow at the Analytical Chemistry Department of Kazan Federal University*

### **Short CV**

2008 – 2013 Academic study at the Alexander Butlerov Institute of Chemistry, Department of Analytical Chemistry. Diploma work: "Impedimetric and piezometric sensors for DNA damage determination"

2013 – 2017 Post-graduate course on analytical chemistry at the Alexander Butlerov Institute of Chemistry, Department of Analytical Chemistry.

February 2017 Defense of the candidate of science thesis in analytical chemistry (an equivalent to Ph.D.) "DNA-sensors based on electropolymerized and hybrid materials for the determination of oxidative DNA damage"

### **Scientific Experience**

2016 – 2019 Junior researcher at the laboratory of electrochemical DNA-sensors of Kazan Federal University

2019 – at present Researcher at the Analytical Chemistry Department of Kazan Federal University

### **Honors and Memberships**

Award of National scholarship programme of the Slovak Republic for the support of mobility of students, PhD students, university teachers, researchers and artists (2013)

Special scholarship of Tatarstan Republic (2016)

Award of Tatarstan Academy of Sciences for young scientists (2019)

### **Scientific interests**

Electropolymerized materials, redox mediators, electrochemical sensors

### **Key publications**

1. Kuzin, Y.I.; Padnya, P.L.; Stoikov, I.I.; Gorbachuk, V. V.; Stoikov, D.I.; Khadieva, A.I.; Evtugyn, G.A.

Electrochemical behavior of the monomeric and polymeric forms of

N-phenyl-3-(phenylimino)-3H-phenothiazin-7-amine. *Electrochim. Acta* 2020, 345, 136195,

doi:10.1016/j.electacta.2020.136195.

2. Kuzin, Y.; Kappo, D.; Porfireva, A.; Shurpik, D.; Stoikov, I.; Evtugyn, G.; Hianik, T. Electrochemical DNA sensor based on carbon black—poly(Neutral red) composite for detection of oxidative DNA damage. *Sensors (Switzerland)* 2018, 18, doi:10.3390/s18103489.

3. Gorbachuk, V. V.; Porfireva, A. V.; Stepanova, V.B.; Kuzin, Y.I.; Evtugyn, V.G.; Shamagsumova, R. V.; Stoikov, I.I.; Evtugyn, G.A. Co-polymers of oligolactic acid and tetrasubstituted thiacalix[4]arenes as a new material for electrochemical sensor development. *Sensors Actuators, B Chem.* 2017, 246, 136–145, doi:10.1016/j.snb.2017.02.061

### **Website**

<https://kpfu.ru/chemistry/struktura/kafedry/kafedra-analiticheskoy-himii>

# NEW PHENOTHIAZINE DERIVATIVES AS REDOX MEDIATORS: KINETICS OF ELECTRODE REACTION, ELECTROPOLYMERIZATION AND ANALYTICAL APPLICATIONS

*Kuzin Y.I., Khadieva A.I., Padnya P.L.*

Kazan Federal University, Kazan, Russia

PhD

[JKuzin@kpfu.ru](mailto:JKuzin@kpfu.ru)

The design of compact devices for the determination of various biologically and/or medically important compounds is an urgent direction of the modern analytical chemistry. Electrochemical (bio)sensors represent an excellent alternative to conventional expensive and time-consuming instrumentation. The signal of such electrochemical sensors and biosensors sufficiently depends on specially designed electroactive compounds implemented in the surface layer. Besides signal generation, such compounds can also serve as matrices for immobilization of biochemical components and artificial receptors and their electric wiring [1]. Electropolymerization is a process resulted in deposition of oligomeric and polymeric products of anodic oxidation of many monomeric dyes and other reactive species. Recently electropolymerization has attracted growing attention as one of most promising approaches to the design of modified electrodes due to a number of obvious advantages it possesses, i.e., variation of the electrode size and shape; compatibility with the microsensor and flow-through sensor format; easy control of the deposited mass and coating thickness by specifying the number of the potential cycles; satisfactory repeatability and simplicity of the sensor regeneration after its contact with the analyte molecules [2].

Phenazine and phenothiazine dyes are ones of the best candidates for application in electrochemical (bio)sensors due to variety of electrochemical activity attributed to the heteroaromatic core and to the electron donating properties of appropriate nitrogen (sulfur) heteroatoms. Functionalization of these dyes with additional substituents alters their redox properties and electropolymerization abilities and hence can affect the performance of appropriate sensors. Although the products of electropolymerization of phenazines and phenothiazines do not exert electroconductivity as polyaniline, they show remarkable redox response in a certain window of the potential applicable for solution of many analytical problems. Thus, this signal can be used for detection of the products of enzymatic reactions [3]. Electroactive polymers on phenothiazine platform have also found application in the development of supercapacitors [4].

Successful application of the monomeric and polymeric forms of the phenazine (phenothiazine) dyes calls for further investigation of these compounds for their use in new (bio)sensors with improved characteristics. The progress in this area depends on the variety of the structure of precursors and establishing relationships between the functionalization of the heteroaromatic core and their electrochemical properties including polymerization ability. In this work, we investigated electrochemical behavior of three new phenothiazine derivatives (Fig. 1). The influence of the substituents nature on the electrochemical behavior of the monomeric forms and on their electropolymerization has been evaluated for different experimental conditions, including the pH influence of voltammetric signals and the parameters and limiting step of the electron transfer. The schemes of the electrode reactions of new phenothiazine derivatives on the glassy carbon electrode surface have been proposed. Applicability of the electrosynthesized derivatives as modifying films of (bio)sensors were estimated in potentiometric and impedimetric modes.

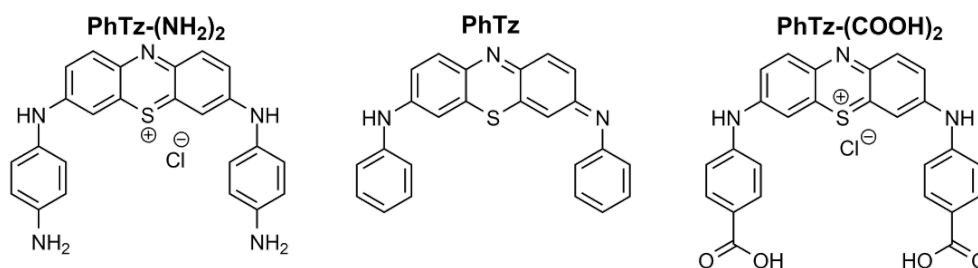


Figure 1. New phenothiazine derivatives

## References

- [1] Tao T., Zhou Y., Ma M., He H., Gao N., Cai Z., Chang G., He Y. *Sens. Actuator B-Chem.* **2021**, 328
- [2] Evtugyn G., Porfireva A, Hianik T. *Advanced Bioelectronics Materials*, Wiley, New York. **2015**, 89-185
- [3] Da Silva W., Ghica M.E., Brett C.M.A. *Electrochim. Acta*, **2019**, 317, 766-777
- [4] Otteny F., Kolek M., Becking J., Winter M., Bieker P., Esser B. *Adv. Energy Mater.* **2018**, 8(33), 1802151

Acknowledgements. Financial support of Russian Science Foundation (Grant no 19-73-10134) is gratefully acknowledged.





## **Prof. Robert A. Evarestov**

*Head of Department of Quantum Chemistry – St. Petersburg State University, St. Petersburg, Russian Federation*

### **Short CV**

Robert A. Evarestov graduated from St. Petersburg State University with a degree in Theoretical Physics in 1960, and received his Ph.D. in Theoretical Physics from the same university in 1964.

In 1977 he completed his postdoctoral degree with a thesis on "Molecular models in the electronic structure theory of crystals." He has worked at the Department of Quantum Chemistry of St. Petersburg State University since 1968, and became a Professor there in 1979.

He is a Foreign Member of the Latvian Academy of Science (from 2005), and a recipient of the Humboldt Foundation Award (1998).

### **Scientific interests**

His research interests include symmetry of crystalline solids (his monograph "Site Symmetry in Crystals" was published by Springer in 1993, second edition in 1997), the application of quantum chemistry methods to perfect and defective crystals (his book "Quantum Chemistry of Solids" was published by Springer in 2007, second edition in 2012), and symmetry and quantum chemical study of monoperiodic nanostructures (nanotubes, nanowires). The first edition of his monograph "Theoretical Modeling of Inorganic Nanostructures: Symmetry and ab-initio Calculations of Nanolayers, Nanotubes and Nanowires" was published by Springer in 2015, in the second edition this book was extended and published in 2020.

### **Key publications**

1. Sergei A. Egorov, S. A.; Evarestov, R. A. Colossal Spin Splitting in the Monolayer of the Collinear Antiferromagnet MnF<sub>2</sub>, *Journal of Physical Chemistry Letters*, 2021, 12, 2363-2369. DOI: 10.1021/acs.jpcclett.1c00282
2. Bandura, A. V.; Lukyanov, S. I.; Kuruch, D. D.; Evarestov, R. A. Multi-walled MoS<sub>2</sub> nanotubes. First principles and molecular mechanics computer simulation, *Physica E – Low-Dimensional Systems & Nanostructures*, 2020, 124, 114183. DOI: 10.1016/j.physe.2020.114183
3. Evarestov, R. A.; Kovalenko, A., V.; Bandura, A., V". First-principles study on stability, structural and electronic properties of monolayers and nanotubes based on pure Mo(W)S(Se)<sub>2</sub> and mixed (Janus) Mo(W)SSe dichalcogenides, *Physica E – Low-Dimensional Systems & Nanostructures*, 2020, 115, 113681. DOI: 10.1016/j.physe.2019.113681
4. Domnin, A. V.; Bandura, A. V.; Evarestov, R. A. First-Principles Calculations of Phonons and Thermodynamic Properties of Zr(Hf)S<sub>2</sub>-Based Nanotubes, *Journal of computational Chemistry*, 2020, 41. DOI: 10.1002/jcc.26124
5. Porsev, V. V.; Bandura, A. V.; Lukyanov, S. I.; Evarestov, R. A. Expanded hexagonal nanohelicenes of zigzag morphology under elastic strain: A quantum chemical study, *Carbon*, 2019, 152, 755-765. DOI: 10.1016/j.carbon.2019.06.036

### **Website**

<http://quant.chem.spbu.ru/>

# FIRST PRINCIPLES STUDY OF HELICAL NANOSTRUCTURES: A CASE OF NANOHELICENES

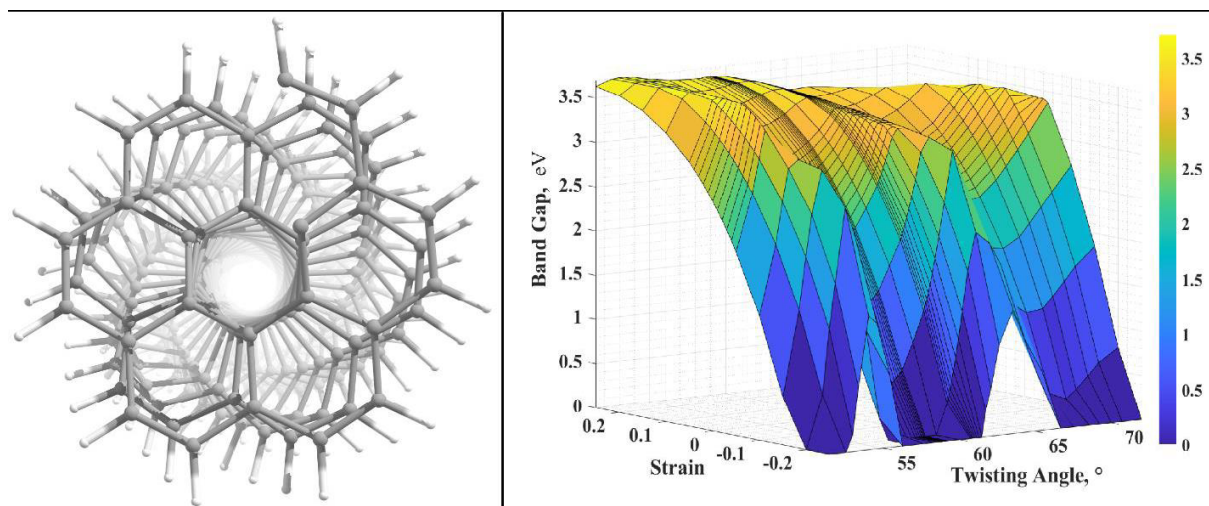
*Evarestov R.A.<sup>1</sup>, Porsev V.V.<sup>1</sup>*

<sup>1</sup>Saint Petersburg State University, Saint Petersburg, Russia  
[r.evarestov@spbu.ru](mailto:r.evarestov@spbu.ru)

Helicenes are defined as polycyclic aromatic compounds with nonplanar screw-shaped skeletons formed by ortho-annulated benzene or other aromatic rings. Due to their chiral morphology helicenes have many interesting electronic and optical properties. Infinitely extended helicenes (nanohelicenes) have continuous  $\pi$ -systems and the spring topology and are characterized by a strong dependence of properties on axial strain [1]. Semiconductors, metals, ferro- and antiferromagnets are found among the nanohelicenes [2,3,4].

Previous quantum chemical modeling of nanohelicenes was carried out under the constraint that the coils are located exactly one above the other and the system is monoperoic with the six order screw axis symmetry of Rod group  $P6_1$ . However, it is known for molecular helicenes that the coils are twisted relative to each other. It is obvious that the artificial imposing of the  $P6_1$  symmetry in nanohelicenes modeling simplifies the real picture.

To study the real structure of nanohelicenes, we have developed a new approach based on line symmetry groups application [5]. The line groups describe the symmetry of quasi-one-periodic systems, both monoperoic (called also commensurate), in particular, stereo-regular polymers, and nonperiodic (incommensurate). Our quantum chemical calculations showed that nanohelicenes with real (incommensurate) symmetry can be modeled by monoperoic systems with helical symmetry.



The presented approach has a great generality and allows one to consider monoperoic and quasi-one-periodic systems as well as their torsion and axial distortions. In particular, our approach allows one to find the dependence of Young's modulus on torsion, or to obtain two-parameter (uniaxial strain and twisting angle) maps of the electronic band gap.

## References

- [1] Daigle M., Miao D., Lucotti A., Tommasini M., Morin J.-F. *Angew. Chem. Int. Ed.* **2017**, 56, 6213-6217
- [2] Korhonen T., Koskinen P. *AIP Advances* **2014**, 4, 127125
- [3] Zhang X., Zhao M. *Sci. Rep.* **2014**, 4, 5699
- [4] Porsev V.V., Bandura A.V., Lukyanov S.I., Evarestov R.A. *Carbon* **2019**, 152, 755-765.
- [5] Damnjanović M., Milošević I. *Line Groups in Physics. Theory and Applications to Nanotubes and Polymers*, Lect. Notes in Phys., 801, Springer, Berlin Heidelberg, **2010**.



## **Mr. Andreas Röckert**

*PhD student at the Department of Chemistry – Ångström Laboratory, Uppsala University, Uppsala, Sweden*

### **Short CV**

Andreas Röckert studied chemical engineering at Uppsala University and obtained his bachelor's degree in 2015. In 2017 he graduated with a master's and an engineering degree from the same university with a diploma work titled "Electronic structure of organic-inorganic lanthanide iodide perovskite solar cell materials." During his undergraduate studies, he received four scholarships for academic excellence.

He started his PhD studies in 2017 in computational chemistry with a focus on molecular adsorption on metal oxide surfaces

### **Scientific interests**

His research focuses on studying hydrated and hydroxylated metal oxide surfaces and nanoparticles using computational chemistry methods. The work is three-fold: (i) identifying relevant surface structures, (ii) investigating structure-property relations, and (iii) develop new computational workflows for generating vibrational spectra from quantum mechanical calculations

### **Key publications**

A. Röckert, J. Kullgren, P. Broqvist, S. Alwan, and K. Hermansson, The water/ceria(111) interface: Computational overview and new structures, *J. Chem. Phys.*, 2020 152, 104709, doi: 10.1063/1.5142724

### **Website**

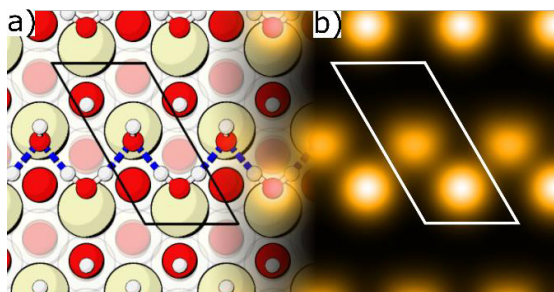
<http://www.teoroo.kemi.uu.se/>

<sup>1</sup>Uppsala University, Uppsala, Sweden  
Student  
[andreas.rockert@kemi.uu.se](mailto:andreas.rockert@kemi.uu.se)

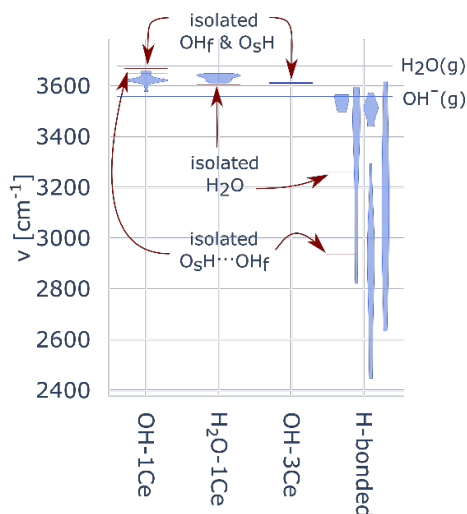
The water-metal oxide interface governs the phase stability of hygroscopic metal oxide nanoparticles and dictates their reactivity and functionality, such as hydrophobicity. Molecular-level characterization of the surface-bound OH species (e.g. -OH<sub>2</sub>, -OH-, H-bonded -OH) helps rationalize the interface's stability and functionality. [1]

Theoretical calculations are crucial to providing structural and thermodynamic models to interpret results from surface-sensitive experiments. This presentation will describe how we use static and dynamical DFT calculations of water on cerium oxide (CeO<sub>2</sub>, ceria) to understand the hydration and hydroxylation of metal oxide surfaces.

On the thermodynamically dominating ceria(111) surface, we find that the stability of water is maximized at 1.0 ML coverage, and partial dissociation of 50 % or less is likely. In static simulations, the water molecules form 1D-chains of alternating H<sub>2</sub>O and OH<sup>-</sup> groups; this is the example given in the Figure 1. The coverage-dependent adsorption energies are consistent with the experimental results available from the literature. [2] At finite temperatures and full hydration, the water structures in contact with the surface form a distorted hexagonal structure with a partially hydroxylated interface layer.



**Figure 1.** One dimensional water chain at 1.0 ML coverage on ceria(111) where 50 % of water is dissociated. Its atomic structure (a) and simulated STM imaging (b).



**Figure 2.** The calculated frequencies of surface-bound OH species depend on the chemical environment.

Computational vibrational analysis was used to correlate the frequency with the local structure surrounding surface-bound OH species. We find that the OH vibrational frequencies,  $\nu(\text{OH})$ , are to a small degree governed by the coordination with surface cations and to a large degree by H-bonding (Figure 2). The magnitude of  $\nu(\text{OH})$  can be ordered by the type of H-bond acceptor and correlates tightly with  $R(\text{H}\cdots\text{O})$  as a structural descriptor or with the electric field strength from the surroundings. [4]

## References

- [1] Mullins D.R. Surface Science Reports **2015** 70, 42–85
- [2] Röckert A., Kullgren J., Broqvist P., Alwan S., and Hermansson K. J. Chem. Phys. **2020**, 152, 104709
- [3] Hackenstrass K. **2021** Master's thesis, Uppsala University
- [4] Röckert A., Kullgren J., Hermansson K. **2021** Submitted

Acknowledgments. This work was supported by Swedish Research Council (VR) and the Swedish National eScience Initiative (eSENCE), and the Swedish National Infrastructure for Computing (SNIC)



## **Prof. Sergey Adonin**

*Habilitated Professor Leading Researcher of the Institute of Organic Chemistry SB RAS, Novosibirsk, Russia*

### **Short CV**

Graduated from the Faculty of Natural Sciences of Novosibirsk State University in 2009. In 2012 he defended his Ph.D. thesis, in 2019 - habilitation at the Institute of Chemistry of the SB RAS. Author (co-author) of over 100 publications in journals indexed by Scopus and Web of Science. H-index (Scopus) = 20. Finalist for the Reaxys Ph.D. Prize (2013), laureate of the European Academy Prize for

Young Scientists (2013), personal scholar of the Government of the Novosibirsk Region (2010), Haldor Topsoe scholar (2010). Laureate of the International Fernando Pulidori Prize (2017), Academician Volpin (2017), the Reaxys Award Russia (2019), winner of the Yu.T. Struchkova (2018). In 2018 and 2019, he was among the top 1% of scientific reviewers in the world according to Publons

### **Scientific interests**

Coordination chemistry of p-elements, supramolecular coordination chemistry, halogen bonds in solids and in solutions

### **Key publications**

1. Novikov, A. V.; Usoltsev, A. N.; Adonin, S. A.; Bardin, A. A.; Samsonenko, D. G.; Shilov, G. V.; Sokolov, M. N.; Stevenson, K. J.; Aldoshin, S. M.; Fedin, V. P.; Troshin, P. A., Tellurium complex polyhalides: narrow bandgap photoactive materials for electronic applications. *J. Mat. Chem. A* 2020, 8 (42), 21988–21992. doi: 10.1039/d0ta06301k.
2. Adonin, S. A.; Usoltsev, A. N.; Novikov, A. S.; Kolesov, B. A.; Fedin, V. P.; Sokolov, M. N., One- and Two-Dimensional Iodine-Rich Iodobismuthate(III) Complexes: Structure, Optical Properties, and Features of Halogen Bonding in the Solid State. *Inorg. Chem.* 2020, 59 (5), 3290–3296. doi: 10.1021 / acs.inorgchem.9b03734.
3. Adonin, S. A.; Udalova, L. I.; Abramov, P. A.; Novikov, A. S.; Yushina, I. V.; Korolkov, I. V.; Semitut, E. Y.; Derzhavskaya, T. A.; Stevenson, K. J.; Troshin, P. A.; Sokolov, M. N.; Fedin, V. P., A Novel Family of Polyiodo-Bromoantimonate(III) Complexes: Cation-Driven Self-Assembly of Photoconductive Metal-Polyhalide Frameworks. *Chem.–Eur. J.* 2018, 24 (55), 14707–14711. doi: 10.1002 / chem.201802100

## POLYHALOGEN-HALOMETALATES OF 15 AND 16 GROUP ELEMENTS

Adonin S.A.<sup>1,2</sup>

<sup>1</sup>Nikolaev Institute of Inorganic Chemistry SB RAS, Novosibirsk, Russia

<sup>2</sup>South Ural State University, Chelyabinsk, Russia

adonin@niic.nsc.ru

Ability of halide complexes (hetero- or, more commonly, homoleptic) to form inclusion compounds with di- or polyhalogens via halogen bonding (XB) was noticed decades ago. Surprisingly, this feature was not systematically studied for years; after a long pause, this area experiences revival nowadays. The talk covers the results obtained by our group within the last few years: the family of structurally diverse polyhalide-halometalates of Group 15 and 16 elements, as well as their physical properties relevant to modern materials science.

Acknowledgements. This work was supported by Russian Science Foundation (Grant. No. 18-73-10040).



## **Prof. Julien Bachmann**

*Full Professor, Friedrich-Alexander University of Erlangen-Nürnberg (Erlangen, Germany) and Saint Petersburg State University (St. Petersburg, Russia)*

### **Short CV**

Julien Bachmann studied chemistry at the University of Lausanne, Switzerland, and graduated in 2001. He obtained his Ph. D. in inorganic chemistry from MIT in 2006, then moved with a Humboldt Fellowship to the Max Planck Institute of Microstructure Physics in Germany. He became an Assistant Professor in physics and chemistry in Hamburg in 2009 energy-converting nanostructured interfaces, and was subsequently appointed as an Associate Professor of Inorganic Chemistry at the Friedrich-Alexander University of Erlangen-Nürnberg (FAU) in 2012. In July 2017 he was promoted to Full Professor, and he now leads the Chair for 'Chemistry of Thin Film Materials' at FAU. Since 2017, he has also held an appointment as a Professor of Saint Petersburg State University.

### **Scientific interests**

Research in the Bachmann group focuses on the development of preparative methods for nanostructured inorganic materials and interfaces at which various types of energy conversion phenomena can be studied. They create inorganic nanostructures with accurately tunable geometry, and they study their physical and chemical properties systematically as they vary with the geometric parameters. They are particularly interested in the transport and exchange of electrons and ions at interfaces in solar cells, batteries, and other electrodes

### **Key publications**

1. Büttner, P.; Scheler, F.; Pointer, C.; Döhler, D.; Barr, M.K.S.; Koroleva, A.; Pankin, D.; Hatada, R.; Flege, S.; Manshina, A.; et al. Adjusting Interfacial Chemistry and Electronic Properties of Photovoltaics Based on a Highly Pure Sb<sub>2</sub>S<sub>3</sub> Absorber by Atomic Layer Deposition. *ACS Appl. Energy Mater.* 2019, 2, 8747–8756, doi:10.1021/acsaem.9b01721.
2. Koch, V.M.; Barr, M.K.S.; Büttner, P.; Mínguez-Bacho, I.; Döhler, D.; Winzer, B.; Reinhardt, E.; Segets, D.; Bachmann, J. A solution-based ALD route towards (CH<sub>3</sub>NH<sub>3</sub>)(PbI<sub>3</sub>) perovskite: Via lead sulfide films. *J. Mater. Chem. A* 2019, 7, 25112–25119, doi:10.1039/c9ta09715e.
3. Haschke, S.; Pankin, D.; Petrov, Y.; Bochmann, S.; Manshina, A.; Bachmann, J. Design Rules for Oxygen Evolution Catalysis at Porous Iron Oxide Electrodes: A 1000-Fold Current Density Increase. *ChemSusChem* 2017, 10, 3644–3651, doi:10.1002/cssc.201701068

### **Website**

<https://www.chemistry.nat.fau.eu/bachmann-group/>



## **Prof. Jef K. De Brabander**

*Full Professor, Julie and Louis Beecherl Jr. Chair in Medical Science  
Department of Biochemistry and Simmons Comprehensive  
Cancer Centr, The University of Texas Southwestern Medical  
Center at Dallas*

### **Short CV**

1987 Ph.D. in Chemistry (Highest Honors), University of Gent, Belgium  
1993 B.Sc. in Chemistry (Distinction), University of Gent, Belgium  
1993-1994 Graduate Teaching Assistant (University of Gent, Belgium)  
1996-1998 Maître d' Assistant (Instructor), Department of Organic Chemistry, University of Geneva, Switzerland  
1998-2003 Assistant Professor, Department of Biochemistry, UT Southwestern Med Ctr.  
2003-2007 Associate Professor, Department of Biochemistry, UT Southwestern Med Ctr.  
Since 2005 Co-Director (with Steven L. McKnight), Chemistry and Cancer Scientific Program of the Simmons  
Comprehensive Cancer Center, UTSW  
2006-2007 Associate Professor, Simmons Comprehensive Cancer Center, UTSW  
Since 2007 Full Professor  
Since 2011 Julie and Louis Beecherl Jr. Chair in Medical Science  
Dr. De Brabander has documented his scientific contributions in over 90 peer-reviewed publications (h-index  
37) and 15 patents, and at >60 major conferences and named lectureships

### **Awards**

1994 Prix STAS par l'Académie Royale des Sciences, des Lettres et des Beaux-Arts de Belgique (STAS-award  
from the Royal Academy of Sciences, Letters and Beautiful Arts of Belgium), December 10, 1994  
1989-1992 Scholarship from the Institute for Scientific Research in Agriculture and Industry (Belgium)  
1994-1995 Fellowship from the Swiss National Science Foundation  
1995-1996 Fulbright-Hays Award  
1995-1996 NATO-fellowship  
2001-2003 Alfred P. Sloan Research fellowship 2001-2003  
2006 "Journal Award" from the editorial boards of Synlett and Synthesis  
2004-2008 Academic Development Program Award from the Chemistry Council of Merck Research  
Laboratories  
2014 Elected Fellow of the American Association for the Advancement of Sciences

### **Scientific interests**

Synthesis of complex small molecules with interesting biological function, discovery of novel  
small-molecule activators of programmed cell death, orexin receptor agonists for the treatment of  
narcolepsy, antitumor agents that selectively target tumor-derived neuronal stem cells and colon cancers  
with APC mutations, and anti-trypanosomal agents for the treatment of African Sleeping Disease

### **Key publications**

1. A Medicinal Chemistry-Driven Approach Identified the Sterol Isomerase EBP as the Molecular Target of TASIN Colorectal Cancer Toxins. P. C. Theodoropoulos, W. Wang, A. Budhipramono, B. M. Thompson, N. Madhusudhan, M. A. Mitsche, J. G. McDonald, J. K. De Brabander, D. Nijhawan, J. Am. Chem. Soc. 2020, 142, 13, 6128–6138.
2. A Multipronged Approach Establishes Covalent Modification of  $\beta$ -Tubulin as the Mode of Action of Benzamide Anti-cancer Toxins. J. M. Povedano, R. Rallabandi, X. Bai, X. Ye, J. Liou, H. Chen, J. Kim, Y. Xie, B. Posner, L. Rice, J. K. De Brabander, D. G. McFadden, J. Med. Chem. 2020, 63, 22, 14054–14066.
3. Gboxin is an oxidative phosphorylation inhibitor that targets glioblastoma, Shi, Y., Lim, S.K., Liang, Q., Iyer, S.V., Wang, H.-Y., Wang, Z., Xie, X., Sun, D., Chen, Y.-J., Tsabar, V., Gutin, P., Williams, N., De Brabander, J.K., Parada, L.F., Nature, 567, 7748, 2019, 341-346.

### **Website**

<https://www.utsouthwestern.edu/labs/de-brabander/research/>



DISCOVERY, TARGET IDENTIFICATION AND VALIDATION OF SMALL MOLECULES THAT AFFECT CELL  
PROLIFERATION

*De Brabander, J.K.*<sup>1</sup>

<sup>1</sup>UT Southwestern Medical Center, Dallas, United States  
Professor of Biochemistry and Julie and Louis Beecherl, Jr., Chair in Medical Science  
jef.debrabander@utsouthwestern.edu

We focus on projects that frame a discovery based research program routed in synthetic chemistry. We collaboratively integrate our synthetic program with molecular pharmacology, biochemistry, and biology. Specifically, our objectives are centered around the design and structure activity relations of bioactive small molecules with unknown mode of action. These will be used as biochemical probes for target ID studies, in conjunction with forward chemical genetic screens.

We are particularly interested in biological pathways essential for cell proliferation. The molecular target for many small molecules that impede cell growth is either unknown or remains ambiguous. The identification of their direct molecular targets provides an opportunity for biological discovery, novel chemical tool reagents, and on occasion, a novel therapeutic approach.

Acknowledgements. Our work is supported by the Robert A. Welch Foundation (I-1422), the Cancer and Prevention Institute of Texas, and the National Institutes of Health.



## **Prof. Alexey Bobrovsky**

*Professor of RAS, Principal Scientific Researcher of Chemistry Department; Moscow State University, Moscow, Russia*

### **Short CV**

#### *Education:*

1991–1996 student, Chemistry Department, MSU, Moscow

1996–1999 Ph.D. student, Division of Polymer Science, Chemistry Department, MSU

1999 got PhD degree (Candidate of Chemical Sciences)

Thesis: "Chiral and photochromic side chain liquid crystalline polymers: synthesis, optical and photo-optical properties"

2010 got Dr. Sci. degree (Doctor of Chemical Sciences)

Doctoral Thesis: "Multifunctional photochromic LC polymer systems"

#### *Employment history:*

1999–2002 Junior Scientific Researcher at Division of Polymer Science, Chemistry Department, MSU, Moscow

2002–2005 Scientific Researcher at Division of Polymer Science, Chemistry Department, MSU, Moscow

2005–2011 Senior Scientific Researcher at Division of Polymer Science, Chemistry Department, MSU, Moscow

2011–2016 Leading Scientific Researcher at Division of Polymer Science, Chemistry Department, MSU, Moscow

2016 – present time Principal Scientific Researcher at Division of Polymer Science, Chemistry Department, MSU, Moscow

### **Awards**

Alexander von Humboldt research fellowship at Philipps Universität Marburg, Prof. J. Wendorff laboratory (2002–2003)

Lomonosov Award of Moscow State University (2006)

Prize of President of Russian Federation for young scientists (2010)

### **Scientific interests**

Liquid crystalline (LC) state of comb-shaped (side-chain) polymers including LC polymer and dendrimer synthesis, structure-property relationships, polymer LC blends, photo-, electro- and thermo-optical phenomena in LC polymer systems, hybrid LC composites, photonic crystals, etc.

### **Key publications**

1. V. P. Shibaev, A. Yu. Bobrovsky, Liquid crystalline polymers: development trends and photocontrollable materials, *Russ. Chem. Rev.*, 2017, 86, 1024–1072. DOI: 10.1070/RCR4747

2. A. Bobrovsky, K. Mochalov, D. Solovyeva, V. Shibaev, M. Cigl, V. Hamplova, A. Bubnov, Laser-induced formation of "craters" and "hills" in azobenzene-containing polymethacrylate films, *Soft Matter*, 2020, 16, 5398–5405, DOI: 10.1039/d0sm00601g

3. A. Bobrovsky, S. Svyakhovskiy, A. Bogdanov, V. Shibaev, M. Cigl, V. Hamplová, A. Bubnov, Photocontrollable Photonic Crystals Based on Porous Silicon Filled with Photochromic Liquid Crystalline Mixture, *Adv. Optical Mater.* 2020, 8, 2001267, DOI: 10.1002/adom.202001267

### **Website**

<http://www.chem.msu.ru/rus/chair/vms/chemmod/welcome.html>

# PHOTOTUNABLE LIQUID CRYSTALLINE COMPOSITES BASED ON POROUS ORGANIC AND INORGANIC MATRICES

*Bobrovsky A.<sup>1</sup>, Shibaev V.<sup>1</sup>, Hamplová V.<sup>2</sup>, Bubnov A.<sup>2</sup>*

<sup>1</sup>Department of Chemistry, M.V. Lomonosov Moscow State University, 1 Leninskie gory, Moscow, 119991, Russia, bbrvsky@yahoo.com

<sup>2</sup>Institute of Physics of the Czech Academy of Sciences, 199/2 Na Slovance, 182 21 Prague 8, Czech Republic

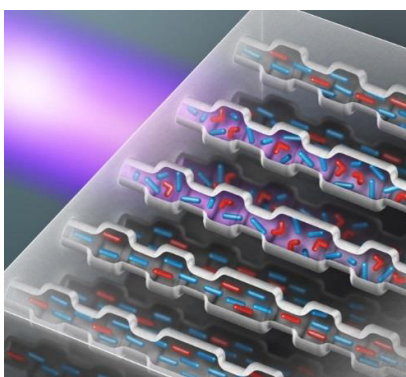
Design and preparation of liquid crystalline (LC) composites is one of the hot topics in modern materials science. An intensive activity in this field is associated with a wide range of possible applications of such “smart” materials predetermined by the combination of unique optical properties of LC systems with specific features of optical and mechanical properties of the different matrices.

This report describes our results on the design and investigation of hybrid composites based on two types of polymer matrices and porous inorganic matrix: (i) porous polyolefines (polyethylene or polypropylene), (ii) porous cholesteric polymer networks and (iii) one-dimensional photonic crystals based on porous silicon. Filling these matrices with low-molar-mass photochromic LC mixtures or LC copolymers enables one to obtain composites with photovisible optical properties.

In the first type of the composites, the highly anisotropic porous structure of polyolefin films provides uniaxial alignment of the nematic phase inside the pores. UV and visible light irradiation enables the dichroism, birefringence and polarized fluorescence photocontrol in the obtained LC composite films.

The second type of the polymer scaffolds is prepared by the photopolymerization of the cholesteric mixtures containing mesogenic mono- and diacrylates followed by removing the low-molar-mass components that allows obtaining a highly porous cholesteric networks. Filling these scaffolds with photochromic LC mixtures capable of the isothermal photoinduced phase transition from nematic to isotropic state results in cholesteric films with phototunable position and width of selective light reflection peak. For the LC composites based on the porous cholesteric networks filled with azobenzene-containing LC copolymer the possibilities of transmission and reflection holographic gratings recording are demonstrated.

The third type of the composites presents photosensitive one-dimensional photonic crystals based on electrochemically etched porous silicon filled with low-molar-mass photochromic LC mixtures (Fig. 1) or copolymers. Irradiation of these composites with non-polarized or polarized light induces a reversible shift of photonic stop band spectral position or modification of its shape.



**Figure 1.** Scheme of the UV-induced isothermal phase transition from nematic to the isotropic state of photochromic LC mixture infiltrated in porous silicon.

LC hybrid composites based on organic and inorganic porous matrices obtained and studied in this work can be considered as promising materials for the applications in photonics and optoelectronics.

**Acknowledgements:** This research was supported by the Russian Foundation for Basic Research (19-03-00337, 19-53-26007) and Russian Science Foundation (19-13-00029).



## **Prof. Hiroyuki Nakamura**

*Professor, Institute of Innovative Research, Tokyo Institute of Technology, Japan*

### **Short CV**

1996 Ph.D. from Tohoku University under the supervision of Prof. Yoshinori Yamamoto  
1995-1997 Assistant Professor at Kyushu University  
1997-2002 Assistant Professor at Tohoku University  
2000-2001 Visiting Assistant Professor at University of Pittsburgh with Prof. Dennis Curran  
2002 Associate Professor at Gakushuin University  
2006 Full Professor at Gakushuin University  
2013 Full Professor at Tokyo Institute of Technology

Prof. Nakamura has over 260 publications (h-index 41) and 33 patents. His research interests include synthetic methodology, medicinal chemistry, chemical biology, and neutron capture therapy. He has been a member of International Advisory Board of Russian Chemical Bulletin since 2019

### **Awards**

The Chemical Society of Japan Award for Young Chemists, 1999  
The Incentive Award of the Japanese Society for Molecular Target Therapy of Cancer, 2007  
Asian Core Program Lectureship Award, 2018

### **Key publications**

1. Asawa, Y.; Yoshimori, A.; Bajorath, J.; Nakamura, H. Prediction of an MMP-1 Inhibitor Activity Cliff Using the SAR Matrix Approach and Its Experimental Validation. *Sci. Rep.* 10, 14710 (2020).
2. Morita, T.; Fuse, S.; Nakamura, H. Novel Photochemical Conversion of Isoxazoles to 5-Hydroxyimidazolines: Possible Protein Labeling at Lysine Residues. *Org. Lett.* 22, 3460-3463 (2020).
3. Otake, Y.; Shibata, Y.; Hayashi, Y.; Kawauchi, S.; Nakamura, H.; Fuse, S. N-Methylated Peptide Synthesis through Acyl N-Methylimidazolium Cation Generation Accelerated by a Brønsted Acid. *Angew. Chem. Int. Ed.* 59, 12645-13222 (2020).

### **Website**

<https://syn.res.titech.ac.jp/en/research/>

# TYROSINE RESIDUE-SPECIFIC CHEMICAL MODIFICATION AND ITS APPLICATION

*Nakamura H.,<sup>1,2</sup> Tsushima M.,<sup>2</sup> Matsumura M.,<sup>2</sup> Sato S.<sup>1,2</sup>*

<sup>1</sup>Laboratory for Chemistry and Life Science, Tokyo Institute of Technology, Yokohama, Japan

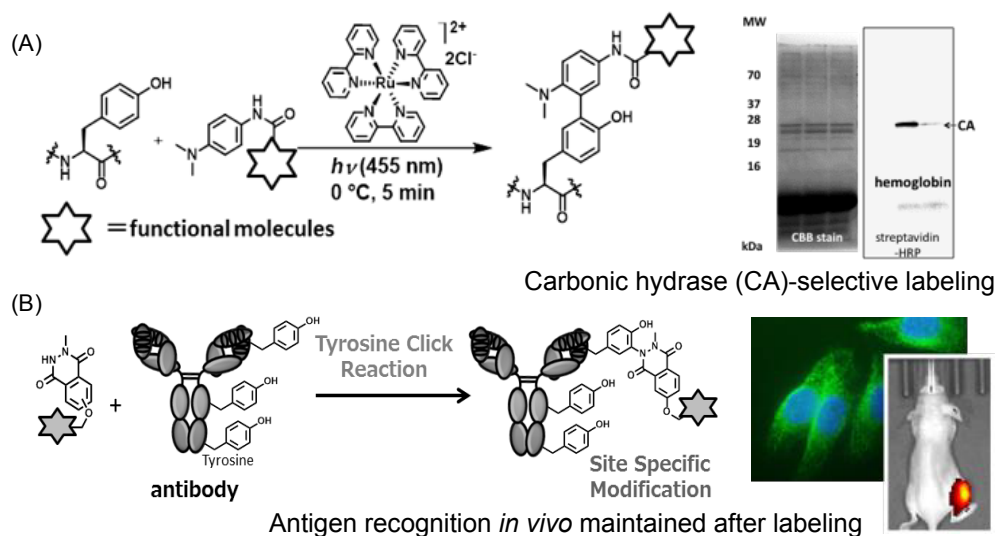
<sup>2</sup>School of Life Science and Technology, Tokyo Institute of Technology, Yokohama, Japan

Professor

[hiro@res.titech.ac.jp](mailto:hiro@res.titech.ac.jp)

Modification of proteins with synthetic chemical probes has become an important technique not only for understanding protein functions, dynamics and cross-talks in cells but also for protein-based therapy in medicine [1]. We have recently developed two types of tyrosine residue-specific modification chemical probes, *N'*-acyl-*N,N*-dimethyl-phenylenediamines and 1-methyl-4-arylurazoles, activated by single-electron transfer (SET) catalysts such as ruthenium photocatalyst (Ru(bpy)<sub>3</sub>) to form a covalent bond at the phenolic hydroxy *ortho* carbon of tyrosine residue. Using these chemical probes, we succeeded in target protein-selective labeling in a protein mixture using a ligand-directed Ru(bpy)<sub>3</sub> catalyst [2-5].

Tyrosine residues were also modified with *N*-methylated luminol derivative, under SET reaction conditions. Horseradish peroxidase (HRP)-catalyzed SET modified surface-exposed tyrosine residues selectively [6]. The reaction was able to be applied to the site-selective antibody chemical modification. In antibody, the presence of a tyrosine residue evolutionarily exposed only in the complementarity-determining region (CDR), and the tyrosine residues in CDR of antibody were selectively modified under HRP-catalyzed SET conditions. CDR-specifically modified antibody was applicable to *in vivo* imaging and antibody-drug conjugates [7].



**Figure 1.** Site-selective tyrosine chemical modification of proteins.

## References

- [1] Dormán, G., Nakamura, H., Pulsipher, A., Prestwich, G. D. *Chem. Rev.* **2016**, *116*, 15284-15398.
- [2] Sato, S., Nakamura, H. *Angew. Chem. Int. Ed.* **2013**, *52*, 8681-8684.
- [3] Tsushima, M., Sato, S., Niwa, T., Taguchi, H., Nakamura, H. *Chem. Commun.* **2019**, *55*, 13275-13278
- [4] Nakane, K., Sato, S., Niwa, K., Tsushima, M., Tomoshige, S., Taguchi, H., Ishikawa, M., Nakamura, H. *J. Am. Chem. Soc.* **2021**, *143*, 7726-7731
- [5] Tsushima, M., Sato, S., Niwa, T., MIURA, K., Taguchi, H., Nakamura, H. *submitted*.
- [6] Sato, S., Nakamura, K., Nakamura, H. *ACS Chem. Biol.* **2015**, *10*, 2633-2640
- [7] Sato, S., Matsumura, M., Kadosono, T., Abe, S., Ueno, T., Ueda, H., Nakamura, H. *Bioconjugate Chem.* **2020**, *31*, 1417 - 1424

Acknowledgements. This work was supported by a Grant-in-Aid for Chemistry for Multimolecular Crowding Biosystems from MEXT, Japan (project No 18H04542 and 20H04699).



# **ANALITICAL CHEMISTRY**

## INFLUENCE OF BENTONITE CLAYS ON GAS CHROMATOGRAPHIC PROFILE OF RED WINE

*Abakumov A.G.<sup>1</sup>, Temerdashev Z.A.<sup>1</sup>, Yakuba Y. F.<sup>2</sup>*

<sup>1</sup>Kuban State University, Krasnodar, Russia

<sup>2</sup>North Caucasian Federal Research Center of Horticulture, Viticulture, Wine-making, Krasnodar, Russia  
[abakumovleks@gmail.com](mailto:abakumovleks@gmail.com)

A large role in the formation of the component composition of wines is played by the technological methods of their production. For example, stabilization and clarification using bentonite clays to remove excessive amounts of components forming clouds of various nature [1]. However, the treatment of wines with bentonite suspensions is not selective. Many authors note that at the stage of clarification and stabilization of wines there is a change in concentrations of amino acids and volatile compounds, as well as phenolic and elemental compositions [2-3].

Knowledge of the qualitative and quantitative content of volatile wine compounds allows you to form "images" characteristic of certain varieties and grape growing places. The main condition in determining the variety and origin of wines is a slight change in their chemical composition or changes should be reproducible in all winemaking processes. Therefore, the contribution of fining agents should be considered when establishing markers determining their variety of wine material.

Red wines produced from the grape varieties Caberne - Sauvignon, Merlo and Moldova, grown in the Krasnodar Territory, were used as objects of study. Upon completion of fermentation, the wines were treated with the same process dosages of suspensions of 32 samples of bentonite clays of varying dispersity and brands. Concentrations of 22 volatile components (1,2-propylene glycol, 1-butanol, 1-hexanol, 1-propanol, 2,3-butylene glycol, 2-propanol, acetoin, isoamyl acetate, isoamylol, isobutanol, isovaleric acid, isobutyric acid, butyric acid, methanol, methyl acetate, acetic acid, acetaldehyde, furfural, ethyl acetate, ethyl caprate, ethyl caproate, ethyl lactate) in each wine was determined using capillary gas chromatography with a flame ionization detector.

Analysis of the obtained data showed that the total content of detectable compounds in wine materials treated with bentonite clays varies in different directions. For all varieties of wines, only acetic aldehyde and 1-butanol are characterized by a decrease in the average concentration in processed wines. Treatment with bentonite clays led to an increase in average concentrations of ethyl lactate, 1-hexanol, isobutyric acid in untreated wines. Treatment of all varieties of wines with bentonite clays has little effect on the contents of ethyl acetate, methanol, 1-propanol, isobutanol and isoamylol.

For the remaining compounds, the clarification and stabilization step results in both an increase and a decrease in the average concentrations of the compounds in the treated wines. Thus, the component composition of the wines can be disturbed during their treatment with bentonite clays. Therefore, the contribution of the fining agents to the gas chromatographic profile of the wines should be considered when establishing markers determining their variety of wine.

### References

- [1] Dordoni R., Colangelo D., Giribaldi M., Giuffrida M., De Faveri D., Lambri M. *AJEV*. **2015**, 66, 518–530.
- [2] Khalafyan A.A., Temerdashev Z.A., Kaunova A.A., Abakumov A.G., Titarenko V.O., Akin'shina V.A., Ivanovets E.A. *J. Anal. Chem.* **2019**, 74, 617-624
- [3] Catarino S., Madeira M., Monteiro F., Rocha F., Curvelo-Garcia A. S., de Sousa, R. *J. Agric. Food Chem.* **2008**, 56, 158–165

Acknowledgements. The study was financed by the Russian Foundation for Basic Research (Project No. 20-33-90046); the scientific equipment was provided by the Centre for Environmental Analysis at the Kuban State University.

# USE OF THE METHOD ICP-AES IN COMBINATION WITH THE GENERATION OF HYDRIDES OF TIN AT THE DETERMINATION IN SEAWATER

*Abakumova D.D., Temerdshev Z.A., Abakumov P.G.<sup>1</sup>*

<sup>1</sup>Kuban State University, Krasnodar, Russia  
[abakumova.dd@gmail.com](mailto:abakumova.dd@gmail.com)

Anthropogenic pollution of aquatic ecosystems is one of the most pressing problems of environmental protection. Heavy metals from water pollutants are one of the most dangerous types of ecotoxicants, since they have several properties that allow them to easily penetrate biological media, accumulate in them, maintain their toxicity for a long time and, thereby, cause great damage to the tissues and organs of living organisms [1]. Tin pollution, which, despite its relatively weak toxic effect, leads to the formation of extremely toxic organic compounds because of biochemical processes [2].

Low tin contents in the analyzed objects create difficulties in its determination even by such a highly sensitive measurement method as inductively coupled plasma atomic emission spectrometry (ICP-AES). This is due to the instrumental difficulties in determining the element, and in the case of seawater analysis, also by strong matrix effects.

The hydride generation technique in combination with ICP-AES makes it possible to achieve more reliable results in the determination of tin. The advantage of the chemical hydride generation technique is the efficiency of introducing the sample into the plasma. In addition, problems arising from matrix influences can be minimized or eliminated entirely by hydride formation, thereby increasing the sensitivity of the detection method [3].

To test seawater, the operating conditions of the iCAP 7400 inductively coupled plasma atomic emission spectrometer (Thermo Scientific, USA) were optimized, including: the speeds of the spray and cooling flows, the power of the high-frequency generator, and the rotation speed of the peristaltic pump. The selection of the optimal oxidizer and its concentration from organic and inorganic acids (formic, acetic, tartaric, nitric, sulfuric and hydrochloric), as well as the optimal concentration of the reducing agent (sodium borohydride) was carried out. It was found that hydrochloric acid provides a more complete and faster reaction for the generation of tin hydrides.

The influence of the main macrocomponents of seawater ( $\text{Na}^+$ ,  $\text{K}^+$ ,  $\text{Ca}^{2+}$ ,  $\text{Mg}^{2+}$ ,  $\text{Cl}^-$ ,  $\text{NO}_3^-$ ,  $\text{SO}_4^{2-}$ ,  $\text{PO}_4^{3-}$ ), as well as minor components ( $\text{Ni}^{2+}$ ,  $\text{Cu}^{2+}$ ,  $\text{Co}^{2+}$ , and  $\text{Fe}^{3+}$ ), which can enter a competing hydride formation reaction due to their higher activity than for tin ions) on the intensity of the analytical signal of tin.

Considering all the optimized parameters, an assessment of the sensitivity and selectivity of the ICP-AES method with the hydride generation technique for the determination of tin under various conditions was carried out. The assessment of the correctness of the proposed scheme was confirmed by the "introduced-found" method.

## References

- [1] L'opez Guerrero M.M, Vereda Alonso E., Cano Pav'on J.M., Siles Cordero M.T., Garc'ia de Torres A. *J. Anal. At. Spectrom.* **2016**, 31, 97-984.
- [2] Cima F. *Encyclopedia of Environmental Health.* **2011**, 351-359.
- [3] Bakirdere S., Aydin F., Bakirdere E.G., Titretir S., Akdeniz I., Aydin I., Yildirim E., Arslan Y. *Appl. Spectrosc. Rev.* **2011**, 46, 38-66.

Acknowledgements. This work was carried out using the scientific equipment of the «Ecological Analytical Center» for Collective Use of the Kuban State University.



## LEVOFLOXACIN-SELECTIVE ELECTRODE

Abdurakhmanova A.K., Tataeva S.D., Magomedov K.E.

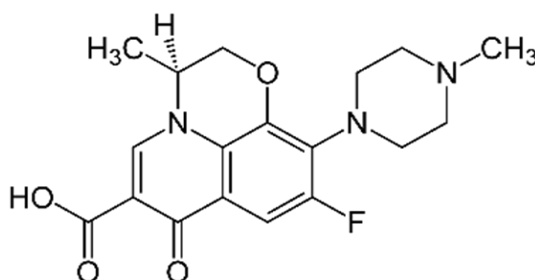
Dagestan State University, Makhachkala, Russia

Student

[abduraxmanova.2001@bk.ru](mailto:abduraxmanova.2001@bk.ru)

Levofloxacin is one of the most studied, which has already become a classic representative of respiratory fluoroquinolones with a wide spectrum of activity[1].

In recent years, there are more and more justifications for the use of these drugs not only in the treatment of respiratory infections, but also skin and soft tissue infections and urogenital infections [2]. Levofloxacin is also prescribed when COVID-19 triggers an inadequate immune response, which is accompanied by the addition of a secondary bacterial infection – pneumonia. It accounts for the vast majority of deaths in COVID-19-positive patients. In this regard, there is a need to determine it in biological fluids and control the quality of dosage forms. For these purposes, it is convenient to use electrodes, since they are simple and accessible for the determination of medicinal substances [3].



**Figure 1.** Levofloxacin formula.

An ion-selective electrode can be defined as an electrochemical sensor with a membrane whose potential serves as a measure of the activity of a certain ion.

The aim of the work is to use levofloxacin as an electro-active component, as well as to study some of the electrochemical characteristics of the electrode.

To achieve the goal and use the levofloxacin-selective electrode, the choice of an electrode-active substance based on the active substance was made. The acid-base properties of levofloxacin were studied, and the spectra of the sensor ingredients in different ratios were taken. A levofloxacin-selective electrode was developed and the possibility of determining the antibiotic in biological fluids was tested.

### References

- [1] Sinopalnikov A. I. "Levofloxacin: role and place in the treatment of lower respiratory tract infections"
- [2] [https://www.rmj.ru/articles/obshchie-stati/Znachenie\\_levofloksacina\\_Tavanika\\_pri\\_respiratornyh\\_infekciyah\\_1/#ixzz6wGtT8PM](https://www.rmj.ru/articles/obshchie-stati/Znachenie_levofloksacina_Tavanika_pri_respiratornyh_infekciyah_1/#ixzz6wGtT8PM)
- [3] E. G. Kulapina, O. V. Barinova. Electrochemical properties of membranes based on associates of physiologically active amines with tetraphenylborate. *Electrochemistry*, **2001**, vol. 37, no. 8. pp. 935-940.

Energy-dispersive X-ray fluorescence (EDXRF) is an analytical method used for determination of elemental composition in different types of samples. The method is fast, non-destructive and does not require sample preparation. Various mathematical protocols were traditionally employed to relate the registered XRF signals with target element concentrations. One of the oldest methods used in this domain is the method of fundamental parameters (FP). It is based on a set of physical parameters [1] employed in the equations relating X-ray fluorescence intensities and element content. The combination of XRF with FP was broadly applied for a broad range of elements and sample types [2]. The main drawback of the method is that the exact elemental composition of samples has to be known. Ordinary least squares regression (OLS) and correction intensity (CI) have also found a broad use in quantitative analysis. Both OLS and CI are based on linear equations employing XRF line intensities and their ratios.

In recent years there was a growing interest to the application of various chemometric tools for processing XRF data, however, no comprehensive comparison between traditional methods and chemometric tools was done so far. This study aims to fill this gap and performs such comparison for processing of EDXRF spectra obtained from two sample sets: steels and ores. The chemometrics approaches are able to take into account sample matrix effects without relying on particular physical model. This approach is faster and can be easily applied for a variety of analytical tasks. The target elements were Cr, Ni and Mn in steels and K, Ca, Fe, Ti, and Mn in ores. The classic multivariate calibration tools like partial least squares (PLS) and K-nearest neighbor regression (KNN-reg) were employed. The results of comparing the performance of these methods to FP, OLS and CI will be discussed in the presentation.

### References

- [1] D.K.G. de Boer Fundamental parameters for X-ray fluorescence analysis. *Spectrochimica Acta Part B: Atomic Spectroscopy*, **1989**, 44, p. 1171. DOI: 10.1016/0584-8547(89)80114-4
- [2] Han, X.Y., Zhuo, S.J., Shen, R.X., Wang, P.L., Ji, A. Comparison of the quantitative results corrected by fundamental parameter method and difference calibration specimens in X-ray fluorescence spectrometry. *Journal of Quantitative Spectroscopy and Radiative Transfer*, **2006**, 97 (1), pp. 68-74. DOI: 10.1016/j.jqsrt.2004.12.018

# STUDY OF MATRIX INFLUENCE ON THE DETERMINATION OF METALS IN ORGANIC SOLVENT SOLUTIONS BY FLAME ATOMIC ABSORPTION SPECTROMETRY

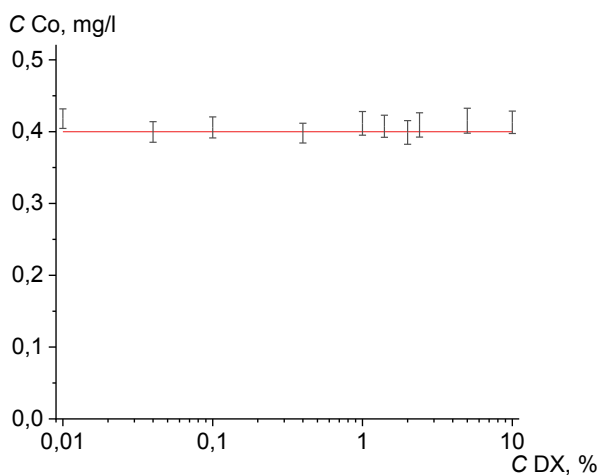
*Aleksandrov T.S., Savinov S.S.*

Saint Petersburg State University, Saint Petersburg, Russia  
Student  
st077084@student.spbu.ru

In modern chemistry of solutions, the study of the properties of three-component systems is a relevant, but at the same time, poorly studied area of research. The relevance of study of these systems lies in the possibility of synthesizing complex compounds that can potentially be used as catalysts [1]. For these purposes, information about quantitative composition of complexes is necessary.

Flame atomic absorption spectrometry (FAAS) is widely used for determination of metals in various samples. FAAS is fast and efficient method with relatively low limits of detection. However, in analysis of organic liquids results can be affected by matrix influence, that is why sample preparation is required [2, 3]. The aim of this study is to develop scheme for determining the content of Ni and Co in the three-component systems NiCl<sub>2</sub>-CoCl<sub>2</sub>-1,4-dioxane and NiCl<sub>2</sub>-CoCl<sub>2</sub>-DMSO by the FAAS. Experimental studies were carried out on a Shimadzu AA-7000 setup using a burner as an atomizer. Reference solutions for calibration curves were prepared by diluting aqueous standard solutions with 1% HNO<sub>3</sub> in deionized water.

It was revealed that the effect of 1,4-dioxane on the optical density of Ni and Co is absent when its concentration is 0.01-10%v/v range (fig. 1). In case of DMSO analytical signal is stable at 0.01-4%v/v and slightly decrease at 10%v of solvent. The effect of Ni and Co on each other's optical density is absent when the ratio of metals is at least 10 to 1. Therefore, it is possible to use simple dilution with 1% HNO<sub>3</sub> as a sample preparation: NiCl<sub>2</sub>-CoCl<sub>2</sub>-1,4-dioxane samples were diluted at least 10 times for analysis, NiCl<sub>2</sub>-CoCl<sub>2</sub>-DMSO were diluted at least 25 times. Accuracy of proposed scheme was confirmed on real three-component samples with different dilution rates and by standard additions.



**Figure 1.** Concentration of Co in solutions with different 1,4-dioxane (DX) content (red line – expected concentration 0.4 mg/l)

## References

- [1] Sipos G., Drinkel E. E., Dorta R. *Chem. Soc. Rev.* **2015**, *44*, 3834-3860
- [2] Mendil D., Uluözliü O.D., Tüzen M., Soylak M. *J. Hazard Mater.* **2009**, *165*, 724-728
- [3] Mohebbi M., Heydari R., Ramezani M. *J. Anal. Chem.* **2018**, *73*, 30-35

Acknowledgements. The study was supported by a grant from the President of the Russian Federation MK-2476.2021.1.3. Scientific research were performed at the Research park of St.Petersburg State University «Center for Chemical Analysis and Materials Research».

# NOVEL ON-LINE CONCENTRATION TECHNIQUES FOR THE SENSITIVE DETERMINATION OF SHORT CHAIN FATTY ACIDS IN THE SERUM SAMPLES

*Antipova K.S.<sup>1</sup>, Makeeva D.V.<sup>1</sup>, Kartsova L.A.<sup>1</sup>*

<sup>1</sup>Saint Petersburg State University, Saint Petersburg, Russia

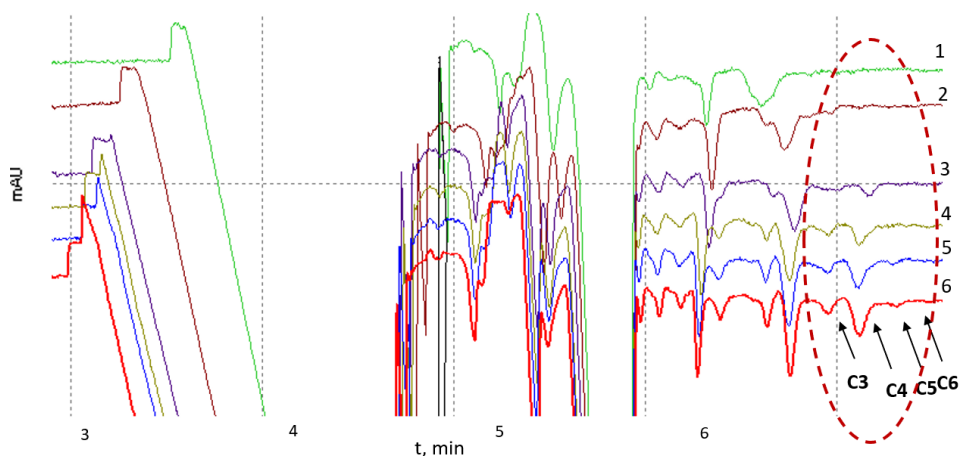
Student

[kсенija\\_97.10@bk.ru](mailto:kсенija_97.10@bk.ru)

Short chain fatty acids (SCFAs) are the final products of the fermentation of indigestible in bowel carbohydrates and branched-chain amino acids. The level of SCFTs concentration in blood serum can indicate inflammatory bowel diseases. Nowadays, the connection between diet and the composition of microbiome and production of SCFAs has not been sufficiently studied, therefore the development of fast and sensible method for the SCFFs (formic, acetic, propionic, butyric, valeric, oxalic acids and etc.) determination in complex objects is an urgent task for targeted metabolic profiling. Capillary electrophoresis (CE) is fast, effective and simple to perform method designed for the analyses of charged compounds. Compared with HPLC and GC, CE does not require an expensive equipment, high amounts of toxic organic solvents and derivatization step of SCFTs, while the significant drawback of low sensitivity of UV-detection can be eliminated by applying on-line sample preconcentration techniques. This study focuses on the development of new on-line concentration approaches for the sensitive determination of SCFAs in a complex matrix with high salt content.

The development of CE method included the following steps: optimization of sample preparation of blood serum (protein precipitation, centrifugation, dilution) and background electrolyte composition (pH, buffer concentration, additives); carrying out of on-line concentration (pH-mediated sample stacking, head-column field amplified sample stacking, dynamic pH-junction).

Application of head-column sample stacking resulted in significant increase of efficiency and 5-10 times decrease of detection limits of SCFAs ( $\sim 50$ -70 ng/mL,  $SEF_h \sim 31$ ) due to the creation of low conductivity zone before the sample zone. The volume of water plug and sample were varied in order to achieve the highest sensitivity (fig 1).



**Figure 1.** Electropherogram of blood serum with application of head-column field amplified sample stacking. Conditions: 1. BGE: benzoic acid, diethanolamine, cetyltrimethylammonium chloride. Indirect detection 254 nm, -20 kV. Hydrodynamic sample injection 50 s 30 mbar, water plug injection: 1. 0 s, 2. 10 s, 3. 30 s, 4. 50 s, 5. 50 s, 6. 70 s, 7. 100 s 30 mbar.

The optimal conditions were applied for the analysis of real object (mouse serum samples). The quantitative analysis data were in accordance with GC-MS chosen as a referent method.

Acknowledgements. This work was supported by the Russian Science Foundation (project No 19-13-00370).

ULTRASOUND-ASSISTED DISPERSIVE LIQUID-LIQUID MICROEXTRACTION COUPLED  
WITH GC-MS FOR ANALYSIS OF 16 POLYCYCLIC AROMATIC HYDROCARBONS  
IN SURFACE WATER

*Arutyunyan Zh.V., Chervonnaya T.A., Musorina T.N., Temerdashev Z.A.*

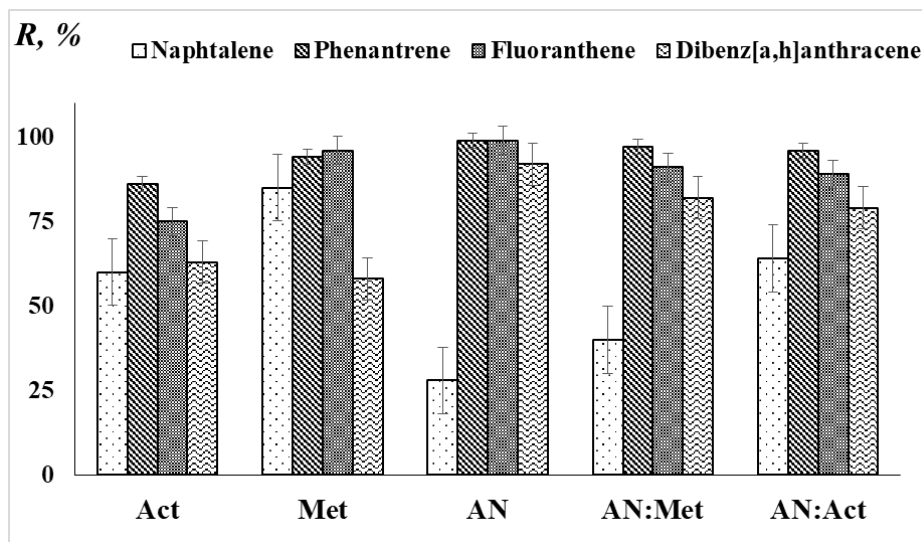
Kuban State University, Krasnodar, Russia

Student

[chervonnaya.t@yandex.ru](mailto:chervonnaya.t@yandex.ru)

The determination of polycyclic aromatic hydrocarbons (PAHs) with the different structures is complicated by their distribution extremely unevenly in natural objects. An urgent task is the development of methods that should have a wide range of their determination. Nowadays, dispersive liquid-liquid microextraction is one of the most efficient extraction analytes from complex matrices of environmental objects. In this work, the application of ultrasound-assisted dispersive liquid-liquid microextraction combined with the GC-MS for the determination of priority PAHs in surface water.

In this work, chloroform was used as an extraction solvent, because it has good chromatography behavior, and the acetonitrile, methanol, acetone, and their mixture, sodium dodecyl sulfate were studied as dispersive agents. The mixture of acetone and acetonitrile were the most efficient for the recoveries of 16 priority PAHs (fig. 1). There were established that the extraction mixture containing acetonitrile more suitable for recovery of PAHs, containing more 4 aromatic rings, and the mixture with methanol the most efficient for the recovery of PAHs, containing 2 and 3 rings. Conditions of ultrasonication and centrifugation were optimized for each extractive mixture.



**Figure 1.** The recoveries of PAHs from water with different dispersive solvents (Act-acetone, Met-methanol, AN-acetonitrile)

According to the results of experiments were proposed three analytical procedures with the GC-MS determination of PAHs in surface water using the different extraction mixture, which provides the determination of 16 priority PAHs, and the determination of groups PAHs, which have different structures.

Acknowledgements. This work was supported by the Russian Foundation for Basic Research (project No 20-43-235001 "r\_Nastavnik\_Krasnodar").

# DEVELOPMENT OF TEMPLATE ELECTROCHEMICAL SYNTHESIS OF SILVER MICROPARTICLES ARRAYS ON FLAT MATRIX SURFACES FOR CREATING ELECTROCHEMICAL SENSORS

*Baburova P.I., Zemtsova E.G., Arbenin A.Y.*

Saint Petersburg State University, Saint Petersburg, Russia

Student

[baburovapolina1999@gmail.com](mailto:baburovapolina1999@gmail.com)

Obtaining of structures with a specific topology is one of the most important areas of materials science in recent decades. Development of new methods for obtaining metal microelectrodes arrays on flat matrix surfaces is of the great interest. Such microelectrodes have a number of advantages over planar electrodes: fast establishment of a stationary diffusion and a higher signal-to-noise ratio for application in electrochemical analysis. Thus, the purpose of this work was to develop template electrochemical synthesis of silver micron particle arrays on flat silicon surface using a polymer template and titanium dioxide.

On the basis of experimental data template electrochemical synthesis of silver microparticles arrays and methodics for obtaining perforated titanium dioxide xerogel films with controlled average mutual distance of perforations were developed. As a result, we obtained materials for the working electrode of an electrochemical sensor based on template synthesis for the determination of cysteine.

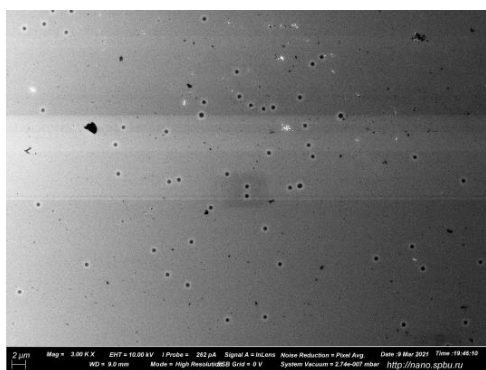


Figure 1. Perforations in TiO<sub>2</sub> xerogel.

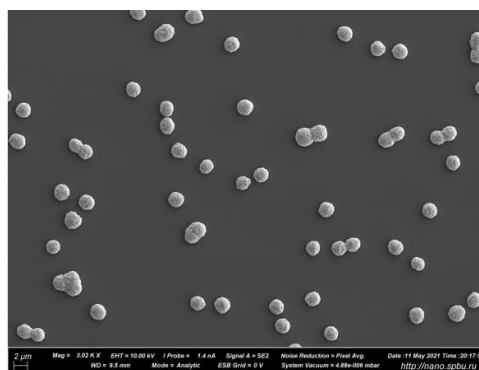


Figure 2. Silver microparticles arrays.

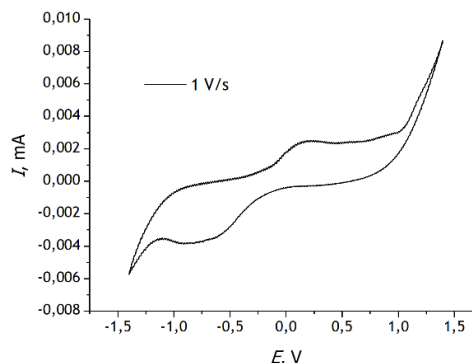
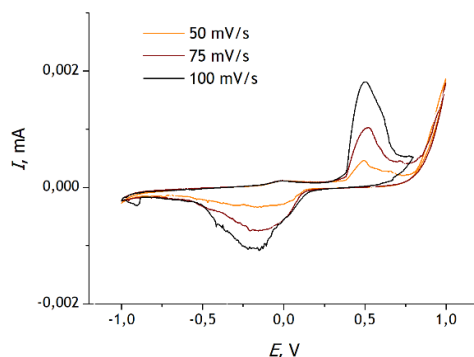


Figure 3. Cyclic voltammograms in cysteine solution taken at different sweep rates.

Research of cyclic voltammograms, using electrodes with an average mutual distance of silver microparticles of 20  $\mu\text{m}$ , showed that both stationary and non-stationary diffusion modes are possible. It opens up the possibility of using these materials for determining electroactive compounds with different diffusion coefficients and similar redox potentials.

## References

[1] Arbenin A. Y. *Materials Research Express*. **2020**, T. 7, №. 3, C. 035401.

The team of authors thanks the Science Park of St. Petersburg State University for their invaluable research assistance.

# AN EFFECTIVE AND ENVIRONMENT-FRIENDLY MICROEXTRACTION SCHEME FOR THE DETERMINATION OF FLUOROQUINOLONES IN MILK

*Barbayanov K.A., Timofeeva I.I., Bulatov A.V.*

Saint Petersburg State University, Saint Petersburg, Russia  
Student

[kirill.barbaaa@gmail.ru](mailto:kirill.barbaaa@gmail.ru)

Nowadays, the use of antibiotics in the agricultural industry is the main method of treatment and prevention of most microbial diseases of animals [1]. Fluoroquinolones are a class of antibiotics which are widely used for the prevention and treatment of various diseases in animal husbandry [2]. The excessive use of these substances can result in the presence of its residue in animal tissue, which contributes to the long-term health effects, including microbial antibiotic resistance and allergic reactions [3]. Therefore, it is an important task to strictly regulate their content in food.

In the current study, an effervescence-assisted dispersive liquid–liquid microextraction based on using deep eutectic solvent (DES) was proposed for the extraction and preconcentration of fluoroquinolones from milk samples. DES are a relatively new class of environmentally friendly solvents, similar in their properties to ionic liquids. The novelty of the developed scheme consists in the use of a three-component DES system, including terpenoid as an acceptor of a hydrogen donor bond, medium-chain fatty acid as a donor of a hydrogen bond and carboxylic acid for the *in-situ* formation of CO<sub>2</sub> for the effective mixing and extraction promotion. The advantages of this approach are simplicity, expressiveness and low cost of reagents. The developed microextraction scheme was coupled with high-performance liquid chromatography with fluorometric detection and applied for the determination of norfloxacin, ofloxacin and fleroxacin in milk samples. The limits of detection, calculated from a blank test based on 3 $\sigma$ , were 0.03  $\mu\text{g kg}^{-1}$  for norfloxacin, ofloxacin and fleroxacin.

## References:

- [1] Jiang, W., Beloglazova N. V., Wang Z., Jiang H., Wen K., de Saeger S., Shen J. Development of a multiplex flow-through immunoaffinity chromatography test for the on-site screening of 14 sulfonamide and 13 quinolone residues in milk. *Biosensors and Bioelectronics* **2015**, 66, 124-128.
- [2] X. Yu, X. Tao, J. Shen, S. Zhang, X. Cao, M. Chen, W. Wang, Z. Wang, K. Wen // A one-step chemiluminescence immunoassay for 20 fluoroquinolone residues in fish and shrimp based on a single chain Fv–alkaline phosphatase fusion protein, *Anal. Methods* **2015**, 7, 9032– 9039.
- [3] M. Crespo-Alonso *et al.*, “Biomass against emerging pollution in wastewater: Ability of cork for the removal of ofloxacin from aqueous solutions at different pH,” *J. Environ. Chem. Eng.* **1**, **2013**, 1199–1204.

Acknowledgements. This project was financially supported by the Russian Science Foundation (project no. № 21-13-00020, <https://rscf.ru/project/21-13-00020/>).

# ELECTRONIC TONGUE AS A TOOL FOR BLADDER CANCER SCREENING: PILOT STUDY

*Belugina R.B.*<sup>1,2</sup>, *Kirsanov D.O.*<sup>2</sup>

<sup>1</sup>ITMO University, Saint Petersburg, Russia

<sup>2</sup>Saint Petersburg State University, Saint Petersburg, Russia

PhD student

[rbelugina@yandex.ru](mailto:rbelugina@yandex.ru)

Bladder cancer is 13<sup>th</sup> most common cause of cancer mortality (2.13%) among different types of cancer worldwide. The bladder cancer mortality is strongly related to sex and age: the highest values are observed among older men. In 2020 the number of bladder cancer deaths in men over 40 was 157 607 (2.97%) [1]. Cystoscopy still remains the main diagnostic procedure for bladder cancer. It has the range of limitations: it is an invasive, time consuming, and relatively expensive procedure. Screening tests help in timely diagnostics, in decreasing mortality rates and in improving cancer treatment outcomes. However, many of the proposed screening tests have shown low sensitivity for low-grade tumors, and performance characteristics of test systems varied from one research to another [2].

Since urine can be obtained non-invasively and its' chemical composition reflects the changes in organism, especially in genitourinary system, it is a suitable material for screening. In the previous works potentiometric multisensor system (or "electronic tongue") demonstrated promising results for prostate cancer diagnostic through urine analysis [3]. We found only a single study devoted to application of electronic tongue as a screening tool for bladder cancer [4]. The authors declared that their system can distinguish the samples from patients with confirmed diagnosis and the control group, however, the studied dataset was quite small and no chemometric classification models with quality metrics were reported.

In this work we aimed to contribute to the study of electronic tongue applicability for bladder cancer screening and to apply various machine learning algorithms for data classification. Potentiometric multisensor system consisting of 24 sensors was applied to analyze 63 urine samples obtained from 31 healthy volunteers and 32 patients diagnosed with bladder cancer. All persons were over 50. To classify healthy volunteers and cancer patients, we employed several machine learning techniques: logistic regression (LR), random forest (RF), support vector machine classifier (SVM), and voting classifier (VC). For all predictions we calculated the following performance metrics: sensitivity, specificity, positive predictive value (PPV), negative predictive value (NPV), and accuracy. Furthermore, we optimized the sensors set to reduce correlations between features. The results are presented in Table 1. All values are given in percent. The details of the study will be provided in the presentation.

**Table 1.** The results of classification.

	<b>LR</b>	<b>RF</b>	<b>SVM</b>	<b>VC</b>
<b>Accuracy</b>	73	71	75	76
<b>Sensitivity</b>	77	73	77	80
<b>PPV</b>	77	73	77	80
<b>NPV</b>	72	72	75	75
<b>Specificity</b>	72	73	76	75

## References

- [1] Cancer Today. International Agency for Research on Cancer, **2020** (Accessed May 2021), <https://gco.iarc.fr/today/home>
- [2] Schmitz-Dräger B.J., Droller M., Lokeshwar V.B., Lotan Y., Hudson M.A., van Rhijn B.W., Marberger M.J., Fradet Y, Hemstreet G.P., Malmstrom P.U., Ogawa O., Karakiewicz P.I., Shariat S.F.: Molecular Markers for Bladder Cancer Screening, Early Diagnosis, and Surveillance: *The WHO/ICUD Consensus. Urol Int.* **2015**, 94, 1-24
- [3] Solovieva S., Karnaukh M., Panchuk V., Andreev E., Kartsova L., Bessonova E., Legin A., Wang P., Wan H., Jahatspanian I., Kirsanov D. *Sens. Actuator B-Chem.* **2019**, 289, 42-47
- [4] Lvova L., Martinelli E., Dini F., Bergamini A., Paolesse R., Di Natale C., D'Amico A. *Talanta.* **2009**, 77(3), 1097–1104

Acknowledgements. This study was supported by the UMNİK program from Foundation for Assistance to Small Innovative Enterprises, Grant 0063076.



# USE OF SIMULATED SPECTRAL DATA FOR VALIDATION OF CLASSIFICATION MODELS: TOWARDS RELIABLE RESULTS OF CANCER STUDIES

*Boichenko E.<sup>1</sup>, Panchenko A.<sup>2</sup>, Kirsanov D.<sup>3</sup>*

<sup>1</sup> Laboratory of artificial sensory systems. ITMO University. St. Petersburg. Russia.

<sup>2</sup> Laboratory of carcinogenesis and aging, FSBI «N.N. Petrov National Medical Research Center of Oncology»  
St. Petersburg, Russia

<sup>3</sup> Institute of Chemistry, St. Petersburg State University, St. Petersburg, Russia.  
PhD student

[ekaterina.boichenko@inbox.ru](mailto:ekaterina.boichenko@inbox.ru)

Numerous spectroscopic techniques have been applied for the distinction of tumor cells from normal ones for various clinical purposes, e.g., early diagnostics of cancer, or intraoperative assessment of tumor margins. Tumor cells show specific spectral features because of reprogrammed metabolism: higher oxygen saturation and glucose level, etc. Usually, the structure of the obtained spectra is complex and requires the application of machine learning methods for data processing, especially for classification tasks. As soon as a classification model appears in the study, a question is begged: how should we validate it? Unfortunately, there is no well-developed and, which is more important, concerted validation strategy for this type of the cancer studies. It makes the direct comparison of the reported results incorrect; besides, these models are often overfitted and the results are often over optimistic and sometimes misleading. The review of Sattlecker et al. reveals a significant problem that leave-one-out cross-validation (LOOCV) is often used as the only way to test multivariate models for cancer diagnosis [1], which seems to be insufficient in this case. Independent test sets are not always an option, because the collection of large number of samples can be difficult at the preliminary steps of research. The choice of a calibration set (or a test set, alternatively) is an additional question to the previous one.

In this study, we suggest to use real data for simulation of new spectral sets with varying characteristics (size, distribution of classes). Simulated data can be used for testing validation algorithms, as long as they reproduce the real data properties, relevant for a classifier, adequately. It could be helpful when measured data set is limited and we cannot create different scenarios to challenge a classification model, e.g. when one class is underrepresented in a test set. Simulating the data, we can create a number of such data sets— an analog of “sandbox” used in software development – and to test how the model generalizes to unseen data.

Near-infrared spectra (939-1796 nm) measured from breast tumors and healthy tissues of mice (152 spectra) were used for simulation of spectral data sets of different size (100, 300, 500 spectra). Thirty-three transgenic female mice of FBV inbred strain were used in this research. The mice expressed HER2/neu gene, which causes spontaneous development of breast cancer. We used a simple simulation method taking spectral baselines from the real data and adding Gaussian peaks, corresponding to the real peaks in near-infrared spectra, with randomly distributed noise. Reproducibility of the real spectral features was verified by Principal Component Analysis of real and simulated data sets and Tucker's coefficient. Several algorithms of train and test set selection have been applied to the simulated data (Kennard-Stone, DUPLEX, random, Monte-Carlo cross-validation), and corresponding Support Vector Machines classification models have been trained, optimized, and validated by using a series of test sets with varying “normal : tumor” classes distribution (1:1,3:1,1:3) and size (10%, 30%, and 50% of the training data set). Performance of the classification models, expressed in values of accuracy, sensitivity, and selectivity, has been compared, and a validation strategy has been proposed.

## References

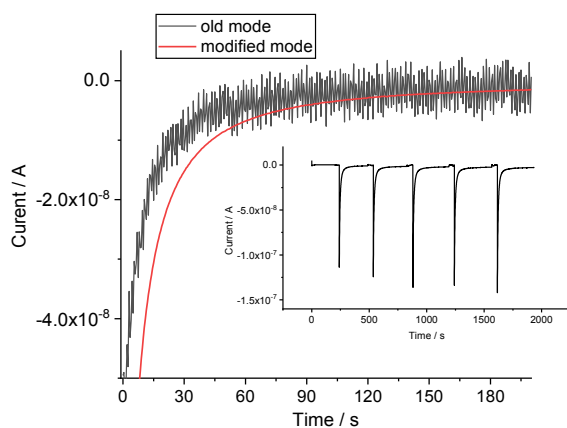
[1] Sattlecker M., Stone N., Bessant C. Trends Anal. Chem. **2014**, 59, 17–25.

Acknowledgements. The reported study was funded by RFBR, project number 20-38-90214.

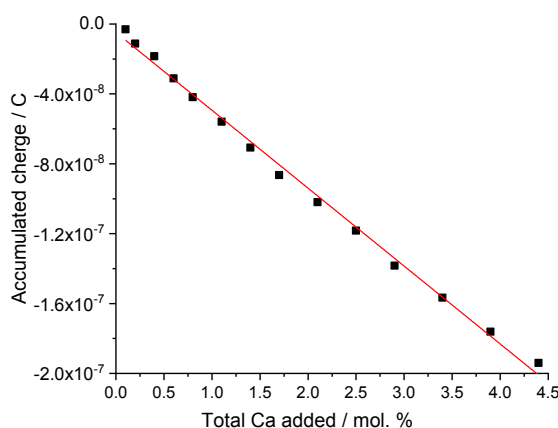
Calcium belongs to the most important blood constituents. In clinical analysis, it is necessary to determine the concentration of ionized calcium, which correlates with its activity [1]. This is routinely done potentiometrically, with ion-selective electrodes (ISEs). However, potentiometric measurements do not provide the sufficient accuracy, the relative error is 1-8%. Recently, a new mode of the measurements with ISEs was invented: the constant potential chronoamperometry/coulometry [2-4]. The potential of the ISE is maintained constant, whereas the potential at ISE/solution interface responds to the ion activity. The resulting current flow is recorded, and the coulometric signal is obtained by integration. This allows for a significant improvement of the sensitivity of the measurements with ISEs.

We here, for the first time, have performed the chronoamperometric/coulometric measurements of Ca<sup>+</sup> with Ca solid contact ISE in blood model solutions and in serum samples. We also propose here a new technique of the deposition of the conducting polymer layer (PEDOT-PSS) on a glassy carbon substrate, which simplifies the procedure significantly. The Ca<sup>2+</sup>-selective membrane containing neutral ionophore Ca I (ETH 1001) was drop-cast on top of the PEDOT-PSS layer. Besides, we also modified the procedure of the chronoamperometric measurements, so the signal-to-noise ratio was improved significantly as compared with the original procedure described earlier [2-5], see Fig. 1.

Measurements of Ca<sup>2+</sup> ion activity in real serum samples in the potentiometric mode and in the chronoamperometric/coulometric mode delivered consistent results. The physiological range of the ionized calcium concentration in the human blood is 1.16 - 1.32 mM. Therefore, the study of the sensitivity to small additions of Ca<sup>2+</sup> was performed using a blood model solution containing initially 1 mM Ca<sup>2+</sup>. The results are presented in Fig.2. One can see that the new mode of the measurements allows resolving 0.1 % change in the Ca<sup>2+</sup> ion concentration. Furthermore, because the additions are much smaller than the initial value, the signal is linear vs. the concentration (i.e. not only in logarithmic scale) which is advantageous for analytical applications.



**Figure 1.** Chronoamperometric signal in the two measurement modes. Inset shows the whole current curve.



**Figure 2.** Additions of CaCl<sub>2</sub> (mol. %) to blood model solutions containing initially 1 mM Ca<sup>2+</sup>.

## References

- [1] Lewenstam A. *Electroanalysis* **2014**, 26, 1171-1181
- [2] Hupa E., Vanamo U., Bobacka J. *Electroanalysis* **2015**, 27, 591-594
- [3] Han T., Mattinen U., Bobacka J. *ACS Sens.* **2019**, 4, 900-906
- [4] Han T., Mousavi Z., Mattinen U., Bobacka J. *J. Sol. State Electrochem.* **2020**, 24, 2975-2983
- [5] Kondratyeva Ye., Tolstopjatova E., Kirsanov D., Mikhelson K. *Sens. Actuat. B* **2020**, 310, 127894

Acknowledgements. This work was supported by the Russian Foundation for Basic Research (project No 19-03-00259).

# OBTAINING CHEMICAL STRUCTURES FROM ESI-MS SPECTRA OF (PRE)CATALYTIC SYSTEMS WITH AN OPEN-SOURCE PYTHON FRAMEWORK, LINEAR PROGRAMMING, AND QUANTUM CHEMICAL MODELING

Bondarenko A.A.<sup>1</sup>, Vlasova Y.S.<sup>2</sup>, Polynski M.V.<sup>1</sup>, Ananikov V.P.<sup>3</sup>

<sup>1</sup> Saint Petersburg State University, Saint Petersburg, Russia

<sup>2</sup> Moscow State University, Moscow, Russia

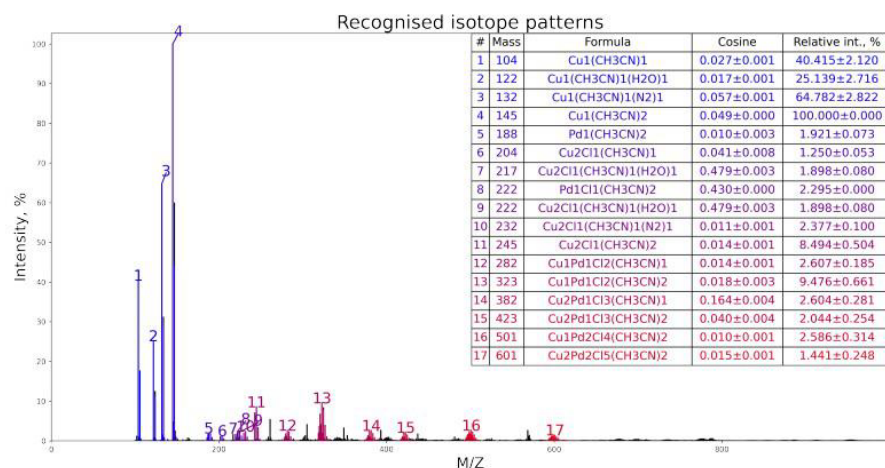
<sup>3</sup> Zelinsky Institute of Organic Chemistry, Moscow, Russia

PhD Student

[emptybox1267@gmail.com](mailto:emptybox1267@gmail.com)

Analysis of data for inorganic catalytic systems requires the application of fine chemical methods to acquire data. Methods based on electrospray ionization spectrometry (ESI-MS) provide a solution to explore catalytic systems and search for various catalytic active clusters or compounds that would be missed with less sensitive methods. Automation of chemical space exploration can boost the research process significantly. Such approaches would allow using data for various computational chemical approaches based on the Big Data strategies and High Throughput Experimentation (HTE) [1-2].

We developed an open-source package written in Python 3 which combines various packages for mass spectrometer data pre-processing and uses simple clustering for the assignment of individual molecular ions with a set intensity threshold. Mean ion mass was used as a target value in solving linear equations to establish candidate empirical formulas with preset restrictions on charge and valence. For established candidate formulae, spectra were calculated via IsoSpec and compared to processed experimental data via cosine similarity function [3-4].



**Figure 1.** Identified by MSARIS PdCl<sub>2</sub>-CuCl ESI-MS positive mode spectra

We tested our workflow on ESI-MS PdCl<sub>2</sub> and CuCl data in acetonitrile for both positive and negative regimes. Our workflow allowed to identify all major signals and provided estimations of their isotope formulae for both positive and negative mode of ESI-MS. For the unequivocal structure assignment of molecular ions, quantum chemical modeling was performed according to a specifically tuned protocol.

Thus, the developed workflow allows to estimate in semi-automatic manner peaks for MS-ESI and provide insights into complex mass-specters like PdCl<sub>2</sub>-CuCl, as well as to determine the molecular structure of ions. Developing our analytical tool would allow to expand and investigate other inorganic systems and significantly boost the exploration of chemical space for various catalytic systems.

## References

- [1] Yunker, L.P., Donnecke, S., Ting, M., Yeung, D., McIndoe, J.S. *Journal of chemical information and modeling*. **2020**, 59, 1295–1300
- [2] McIndoe J.S., Vikse K.L. *Journal of Mass Spectrometry* **2019**, 54, 466-479
- [3] Łacki, M.K., Valkenborg, D., Startek. *Analytical Chemistry* **2020**, 92, 9472–9475
- [4] Romashov, L.V., Rukhovich, G.D., Ananikov, V.P., *RSC advances* **2015**, 5, 107333-107339

## POTENTIOMETRIC METHOD FOR TESTING EXTRACTANTS

*Brechalov A.A.<sup>1</sup>, Babitova E.S.<sup>1</sup>, Timoshenko V.V.<sup>1</sup>, Ermolenko Y.E.<sup>1</sup>, Smirnov I.V.<sup>1, 2</sup>*

<sup>1</sup>Saint Petersburg State University, Saint Petersburg, Russia

<sup>2</sup>Khlopin Radium Institute, Saint Petersburg, Russia

Student

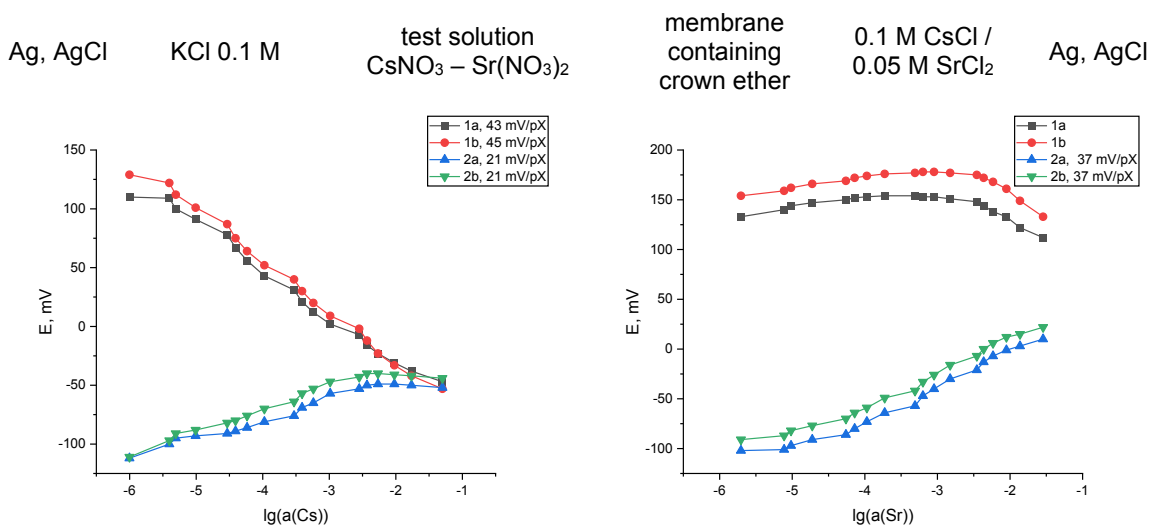
[st052691@student.spbu.ru](mailto:st052691@student.spbu.ru)

The extraction processes of metal cations by various types of crown ethers are described in detail in several works [1-2].

This work aimed to develop a method for determining the selectivity of a few crown ethers for cesium and strontium ions based on the potentiometric method proposed by us.

To create a potentiometric cell, plasticized film membranes were made based on two crown ethers: dibenzo-21-crown-7 (DB21K7) in electrodes (1a, 1b) and di-tert-butyl-dicyclohexyl-18-crown-6 (DtBDCH18K6) in electrodes (2a, 2b).

The electrochemical cell was as follows:



**Figure 1.** Dependence of the potential on the logarithm of the activity of cesium and strontium ions

From the data obtained (Fig. 1), membranes based on crown ether DB21C7 show exceptionally good sensitivity to cesium ions with a practically very weak dependence on changes in the concentration of strontium ions. For membranes based on the crown ether DtBDCH18K6 (Fig. 1), high sensitivity and selectivity to strontium ions compared to cesium ions are shown.

Thus, in this work, it was shown that a potentiometric method for assessing the sensitivity and selectivity of a few crown ethers for alkali and alkaline earth metal ions can be used as the basis for testing various crown ethers as effective selective extractants in radiochemical technologies.

### Reference

- [1] I. H. Gerow a, J. E. Smith Jr. a & M. W. Davis Jr. *Separation Science and Technology* **1981**, 16, 519-548  
 [2] J. F. Dozol, M. Dozol and R. M. Macias. *Journal of Inclusion Phenomena and Macrocyclic Chemistry* **2000**, 38, 1-22.

Acknowledgements. This work was supported by the Russian Science Foundation (project No 20-13-00143).

APPLICATION OF ANALYTICAL METHODS FOR STUDYING THE RATE OF THE PROCESS OF BIODEGRADATION OF COCAMIDOPROPYLBETAINE AND THE METABOLOMIC COMPOSITION OF BACTERIAL CELLS OF THE GENUS *PSEUDOMONAS*

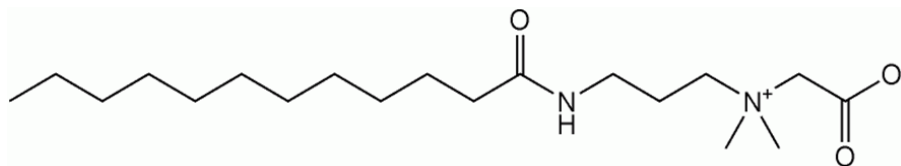
Burlachenko A.S.

Kemerovo State University, Kemerovo, Russia  
Student

[nastyasergeevna99@mail.ru](mailto:nastyasergeevna99@mail.ru)

Cocamidopropylbetaine is an alkylamidobetaine surfactant, representing commercially the most important class of amphoteric surfactants (figure 1). Its toxicity to biological objects has been proved in the articles [1-3].

Objective: to select analytical methods for studying the rate of biodegradation of cocamidopropylbetaine by bacteria of the genus *Pseudomonas* and to study the metabolomic composition of cells.



**Figure 1.** The structural formula of cocamidopropylbetaine.

Objects of research: strains of the All-Russian collection of industrial microorganisms of the National Bioresource Center (BRC VKPM) SIC "Kurchatov Institute" – GosNIIGenetics: *Pseudomonas fluorescens* TR (VKPM B-4881), *Pseudomonas putida* (B-6582) TP-19, *Pseudomonas stutzeri* (B-4904) T, *Pseudomonas putida* (B-2950) TS-18, *Pseudomonas putida* (B-3959) TO, *Pseudomonas mendocina* (B-4710) 2S, *Pseudomonas sp.* (B-8621) TF4-1L.

Methods. The minimum inhibitory concentration of cocamidopropylbetaine was determined by the macromethod. The residual concentration of the surfactant was determined by the spectrophotometric method [4]. The intensity of biomass growth was studied by nephelometry. A static method was used to study the rate of the biodegradation process, and the surfactant concentration was measured in the solution daily. According to the experimental data, a velocity curve was constructed, the reaction order, the velocity constant, and the half-life were determined. We obtained a model of the process by deriving the kinetic equation. The reaction order was determined graphically. The metabolomic composition of microbial cells and the accumulation of degradation products in the culture fluid were determined by HPLC MS.

Results. The minimum inhibitory concentration is 45.6 mmol/dm<sup>3</sup> (15.62 g/dm<sup>3</sup>). As a result of studying the rate of the biodegradation process, the most effective strain-destroyer was found – *Pseudomonas stutzeri* T (B-4904). It showed the highest rate of biodegradation, that is 2.5 times higher than other strains.

The kinetic equation of the reaction of biological decomposition of cocamidopropylbetaine by bacteria of the genus *Pseudomonas* is derived (equation 1):

$$C_t = C_0 \cdot e^{-0,2121 \cdot t} \quad (1)$$

Conclusions. Thus, the most effective strain-destroyer of amphoteric surfactants was selected. A model of the process of biodegradation of the substance is obtained. A metabolomic comparative analysis for cells that were cultured in a classical medium and in a surfactant solution was performed. The decomposition products of cocamidopropylbetaine, which were obtained under the influence of the action of microbial decomposition, were found.

#### References

- [1] Vonlanthen S., Murray T. Brown, Turner A. *Ecotoxicology* **2018**, 20(1), 202–207
- [2] Nogales L.M., Jiménez L.L., Abarca L.E., Gil M.M., López-Nieves M. *International journal of pharmaceutical compounding* **2020**, 24, 358–364
- [3] Hamouda T., Myc A., Donovan B., Shih A.Y., Reuter J.D., Baker J.R. *Microbiological Res.* **2001**, 156(1), 1-7
- [4] Gholami A., Golestaneh M., Andalib Z. *Spectrochimica Acta. Part A: Molecular and Biomolecular Spectroscopy* **2018**, 192, 122–127

Acknowledgements. The work was carried out within the framework of a grant from the President of the Russian Federation with the support of leading scientific schools (SSH-2694.2020.4).

# THE GAS CHROMATOGRAPHY – MASS SPECTROMETRY DETERMINATION PAHS IN ENVIRONMENTAL OBJECTS USING DISPERSIVE LIQUID-LIQUID MICROEXTRACTION

*Chervonnaya T.A., Musorina T.N., Temerdashev Z.A.*

Kuban State University, Krasnodar, Russia

PhD student

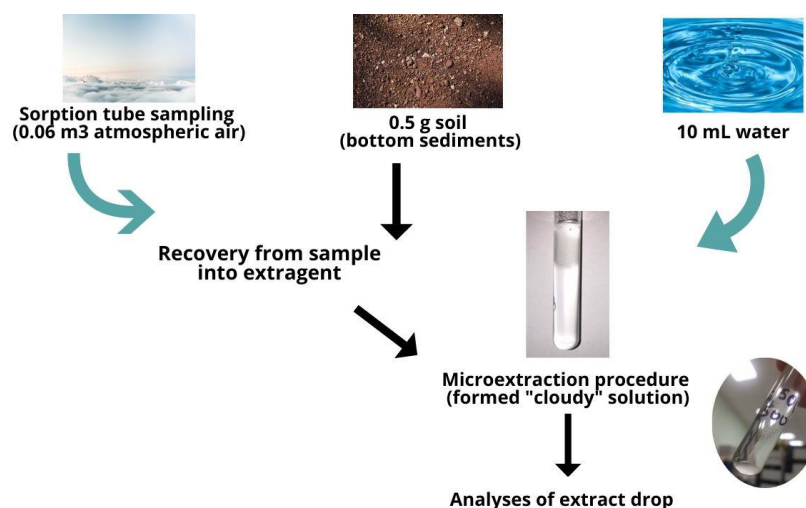
[chervonnaya.t@yandex.ru](mailto:chervonnaya.t@yandex.ru)

Polycyclic aromatic hydrocarbons (PAHs) are ubiquitous environmental contaminants that have carcinogenic, genotoxic, and teratogenic character [1]. Dispersive liquid-liquid microextraction (DLLME) one of the simple, rapid, and efficient methods to extract PAHs from environmental objects [2]. This is variant of sample preparation where one solvent is as a dispersive agent and other is as a extraction solvent, and it make extractive more efficient.

In this work has been developed the universal analytical procedure for the extraction and determination of polycyclic aromatic hydrocarbons in bottom sediments, soils, surface water, and atmospheric air using the DLLME and the Gas Chromatography-Mass Spectrometry method (GC-MS).

The composition and ratio of components in extractive mixtures were optimized and conditions of ultrasonication and centrifugation for the recovery of PAHs from environmental objects. For the extraction of PAHs from atmospheric air was suggested the composition of sorption tube sampling and conditions of desorption analytes were developed. The limits of quantification of PAHs in soils were 0.1 – 0.5  $\mu\text{g}/\text{kg}$  and 10 – 20 ng L- for the determination of PAHs in surface water, and the recoveries of the extraction were 87 – 103%. For air samples, the effective recoveries of PAHs were more than 80 %, and the limits of quantification in the range of 1 ng/m<sup>3</sup>.

Thus in this research was suggested the universal analytical procedure for the determination of PAHs in environmental objects combined with the GC-MS taking into account the specificity of analysis's objects (fig. 1).



**Figure 1.** The procedure of DLLME for the determination of PAHs in environmental objects.

## References

- [1] Park J. S., Wade T.L., Sweet S. *Atmos. Environ.* **2001**, 35, 3241 – 3249
- [2] Avino P., Notardonato I., Perugini L., Russo M. V. *Microchemical Journal.* **2017**, 133, 251 – 257

Acknowledgements. This work was supported by the Russian Foundation for Basic Research (project No 19-43-230003 p\_a).

# A NEW APPROACH TO DIRECT ANALYSIS OF SINGLE CRYSTALS BASED ON PULSED GLOW DISCHARGE MASS SPECTROMETRY

*Chuchina V.*<sup>1,2</sup>, *Gubal A.*<sup>1,2</sup>, *Lyalkin Y.*<sup>1</sup>, *Solovyev N.*<sup>3</sup>, *Ganeev A.*<sup>1,2</sup>

<sup>1</sup>Saint Petersburg State University, Saint Petersburg, Russia

<sup>2</sup>Lumex Ltd., Saint Petersburg, Russia

<sup>3</sup>Institute of Technology Sligo, Sligo, Ireland

PhD Student

[v.chuchina@spbu.ru](mailto:v.chuchina@spbu.ru)

Optical single crystals are widely used in laser optics as laser generators, frequency multiplier, electro-optical shutters, etc. [1]. In the growing of optical single crystals, there are different effects causing inhomogeneous distribution of matrix elements, admixtures, and dopants in the crystal volume [2]. However, direct analysis of matrix and admixture elements in non-conducting crystals is a relevant and difficult analytical task in terms of quality assurance of optical materials. For this reason, in this study the main aim is development and testing of approaches to the direct elemental analysis of single crystals using the example of KTP crystals, pure and doped KF and Rb<sup>+</sup>, and KGd<sub>1-y</sub>Nd<sub>y</sub>(WO<sub>4</sub>)<sub>2</sub> based on glow discharge mass spectrometry.

Firstly, methods for the preparation of the studied dielectric crystals (sample coating with a silver layer and sample pressing in the metallic matrix) for direct analysis using a microsecond glow discharge were developed. Secondly, the discharge parameters, such as repelling pulse delay time, pulse duration, pressure and voltage in discharge were optimized. After that, the samples were analyzed by microsecond direct current pulsed glow discharge time-of-flight mass spectrometry ( $\mu$ s-PDC TOF GDMS). The data were compared with the results obtained by scanning electron microscope-energy dispersive X-ray spectroscopy (SEM EDX) and spectrophotometry and validated by the analysis of certified reference material. Using the designed method, the inhomogeneity of the dopant's distribution was demonstrated along the growth axis and in the growth sectors of different faces [3]. The designed method is applicable for the direct analysis of optical crystal and may be implemented in quality assurance in the manufacturing of optical materials.

## References

- [1] Luo, X.; Li, Z.; Guo, Y.; Yao, J.; Wu, Y. *Solid State Chem.* **2019**, *270*, 674–687
- [2] Solé, R.; Nikolov, V.; Ruiz, X.; Gavaldà, J.; Solans, X.; Aguiló, M.; Díaz, F. *Cryst. Growth* **1996**, *169*, 600–603
- [3] Gubal, A., Chuchina, V., Trefilov, I., Glumov, O., Yakobson, V., Titov, A., Solovyev, N., Ganeev, A. *Crystals* **2020**, *10*, 458

Acknowledgements. This work was supported by the Russian Science Foundation (project No. 17-73-20089). The authors are grateful to the St. Petersburg State University Research Park (St. Petersburg State University, St. Petersburg, Russia): Interdisciplinary Resource Centers for Nanotechnology, Chemical Analysis and Materials, Centre for Microscopy and Microanalysis and “Geomodel”, for providing access to their facilities.

# OBTAINING CHARACTERISTIC URINE PROFILES OF HEALTHY DONORS AND PATIENTS WITH CANCER BY CHROMATOGRAPHY-MASS SPECTROSCOPY

*Deev V.A.<sup>1</sup>, Bessonova E.A.<sup>1</sup>, Kartsova L.A.<sup>1</sup>*

<sup>1</sup>Saint Petersburg State University, Saint Petersburg, Russia  
Student  
[hitcherv@mail.ru](mailto:hitcherv@mail.ru)

Bladder cancer and prostate cancer are among the most common cancers of the genitourinary system [1,2]. Despite the widespread prevalence of this disease, the question of identifying diagnostic biomarkers of this pathology remains open. Currently, the level of prostate-specific antigen (PSA) in the blood is used to diagnose prostate cancer. [3]. Numerous studies have shown insufficient selectivity of this marker. The PSA level increases in the case of benign prostatic hyperplasia and prostatitis [2]. Early detection of pathology significantly increases the patient's chances of recovery and a favorable prognosis. All this makes the further search for methods for diagnosing prostate and bladder cancer an extremely urgent challenge.

In recent years, metabolic profiling has become increasingly common, the essence of which is to obtain information about certain classes of compounds (target) or as many components as possible (non-target). This approach has already made it possible to identify sarcosine as an additional to PSA biomarker of prostate cancer in a large-scale study in Norway [4]. The aim of this work was to obtain characteristic profiles of urine samples from healthy donors and patients with bladder and prostate cancer using liquid and gas chromatography-mass spectrometry.

Previously, we have shown the possibility of classifying urine samples based on the analysis of volatile organic compounds of the equilibrium gas phase by gas chromatography-mass spectrometry with a classification accuracy of more than 95% [5]. The conditions for the precipitation of proteins in urine samples were found. Various options have been tested: organic solvents (methanol, acetonitrile), acids (chloroacetic, acetic, hydrochloric) and their mixtures, but the best results were achieved using chloroacetic acid as a precipitant and centrifuging the solution for 10 minutes at 10,000 rpm.

72 urine samples were analyzed by HPLC-MS after protein deposition, but the small number of detectable components did not allow did not allow the samples to be classified during chemometric processing. To solve these problems, an additional stage of extraction of non-polar components of urine with chloroform was carried out. Then, the organic phase was taken, dried in an air current, and redissolved in a smaller volume of water-acetonitrile solution. The influence of the pH of the medium on the extraction of components has been studied. The best results were observed when acidifying the solution.

The application of chemometric data processing (principal component analysis, nearest neighbor analysis, projection on latent structures) to the obtained chromatographic profiles ensured the classification of samples according to the principle of norm-pathology with the identification of compounds that are most correlated with diseases. Building models involving both pathologies at the same time can reveal specific markers to these diseases.

## References

- [1] Mossanen M.M.D. *Hematology/Oncology Clinics of North America*. **2021**, *35*, 445-455
- [2] Cerrato A., Bedi C., Capriotti A.L., Cavaliere C., Gentile V., Maggi M., Montone C.M., Piovesana S., Sciarra A., Tauler R., Laganà A. *Analytica Chimica Acta*. **2021**, *1158*, 338381
- [3] Henning G.M., Barashi N.S., Smith Z.L. *Clinical Genitourinary Cancer*. **2021**. In Press.
- [4] de Vogel S., Ulvik A., Meyer K., Ueland P.M., Nygård O., Vollset S.E., Tell G.S., Gregory G.F., Tretli S., Bjørge T. *International Journal of Cancer*. **2014**, *134*, 197–206
- [5] Deev V., Solovieva S., Andreev E., Protoshchak V., Karpushchenko E., Sleptsov A., Kartsova L., Bessonova E., Legin A., Kirsanov D. *Journal of Chromatography B: Analytical Technologies in the Biomedical and Life Sciences*. **2020**, *1155*, 122298

*Acknowledgements.* This work was supported by the Russian Science Foundation (project No. 19-13-00370). We express our gratitude to the Resource Educational Center in the direction of Chemistry Science Park of St. Petersburg State University for the equipment provided.



# DEVELOPMENT OF TESTS BASED ON POLYURETHANE FOAM TO DETERMINE THE ACTIVITY OF SOIL UREASE

Veselov A.A., Dergunova E.S., Shiryayeva Yu.A., Dergunova V.V.

Lipetsk State Technical University  
Metallurgical Institute, Department of Chemistry  
[dergunova14@yandex.ru](mailto:dergunova14@yandex.ru)

One of the important indicators that characterize the productivity of soils is its enzymatic activity. Research in this area has been conducted by many scientists who have established the high efficiency of using this indicator to diagnose the dynamics of soil fertility under various anthropogenic and natural impacts on ecosystems.

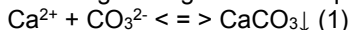
Currently, interest in soil bacteria with urease activity is shown by the construction materials science. Biocementation is an innovative biotechnology based mainly on the use of bacteria that synthesize urease (*Sporosarcina pasteurii*, *Sporosarcina ureae*, etc.). There are two types of microbial calcite deposition (MOC) technology: bioaugmentation (the microbial mass is artificially introduced into the soil) and biostimulation (natural microbes in the soil are stimulated) [1].

The advantage of using this method is the ability to quickly determine the changes occurring in ecosystems at the earliest stages of the development of degradation processes, predict their direction and degree of manifestation. The enzymes studied by us belong to the class of hydrolases, play an essential role in the hydrolytic cleavage of organic substances, enriching the soil with nutrients available to plants. Urease, in particular, catalyzes the hydrolysis of urea to carbon dioxide and ammonia.

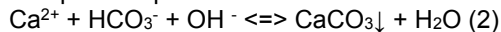
The resulting ammonia serves as a source of nitrogen nutrition of plants. Enzymes accelerate processes and reactions many times over. They are a kind of catalysts for certain types of reactions. So urease accelerates the decomposition of a non-volatile compound-urea:  $\text{CO}(\text{NH}_2)_2 + \text{H}_2\text{O} = 2\text{NH}_3 + \text{CO}_2$ .

Soil bacteria use urea as an energy source and produce ammonium ions ( $\text{NH}_4^+$ ) and carbon dioxide ( $\text{CO}_2$ ), which increase the pH of the environment and cause the deposition of  $\text{Ca}^{2+}$  and  $\text{CO}_3^{2-}$  ions in the form of  $\text{CaCO}_3$ . A local increase in pH is often the reason that microbial cells become nucleation centers for crystallization [2-3].

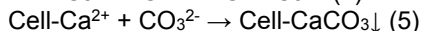
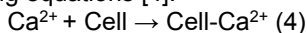
Calcite deposition is described by the following average reaction equation:



Microbiologically induced calcite deposition proceeds in accordance with the equations [2]:



To precipitate calcite according to the above mechanism, calcium ions can be fixed on the surface of the bacterial cell due to its total negative charge. The calcite deposit on the cell surface, which can serve as a nucleation center, is described by the following equations [4]:



The aim of the work is to develop test products based on polyurethane foam as a tool for assessing the urease activity of soils for the subsequent use of soil extracts for biocementation. The method for determining urease activity is based on the reactions of urea hydrolysis under the action of the urease enzyme and the interaction of the released ammonia with the Nessler reagent [4].

Test methods are expressive, accessible, and fairly cheap methods of analysis. These methods do not require expensive equipment and qualified personnel. As a test agent, polyurethane foam was used, which was impregnated with ferrotic salt, Nessler reagent and dried without air access.

A sample of 2 g of soil is placed in a test tube, 4 ml of phosphate buffer (pH=5.7), 0.2 ml of toluene are added, and after five minutes - 4 ml of 10% 24 urea solution. The flask is tightly closed with a cork, stirred and incubated for 24 hours at 37°C. Then the test tubes were interfered with by the test means of the PUF and hermetically sealed. The assessment of the urease activity of the soils was determined after 24 hours by staining the PUF test means using scanner technologies according to a pre-constructed calibration schedule.

The urease activity of 10 soil samples was evaluated using the developed test tools.

## References

- [1] Ramdas V. M., Mandree P., Mgangira M., Mukaratirwa S., Lalloo R., Ramchuran S. *J. of Advanced Research*, **2020**, 21, 51-159
- [2] Lian J., Yan Y., Xu H., Fu D. *Construction and Building Materials*, **2020**, 259, 120384
- [3] Dergunova E.S., Goncharova V.A., Romanchukevich A.Y., Goncharova V.A. *MATEC Web of Conferences*, **2020**, 329, 04008
- [4] Borase D.N., Nath C.P., Hazra K.K., Senthilkumar M., Singh S.S., Praharaj C.S., Singh U., Kumar N. *Ecological Indicators*, **2020**, 114, 06322

# FORMATION OF ORGANIC COMPOUNDS HYDRATES IN HPLC CODNDITIONS

*Derouiche A, Zenkevich I.G*

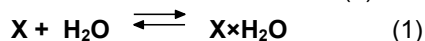
St. Petersburg State University, St. Petersburg, Russia

Student

[st088750@student.spbu.ru](mailto:st088750@student.spbu.ru)

## Introduction:

At the conditions of RP HPLC the analytes (**X**) are located in a water-containing eluent. It means the possibility of their hydrates formation. The method for detection of that (1) was proposed recently [1]:



The sense of this method is the linearization of the dependence  $t_R = f(\mathbf{C})$ , where **C** is the concentration of organic modifier in an eluent, using its recurrent representation:

$$t_R(\mathbf{C} + \Delta\mathbf{C}) = at_R(\mathbf{C}) + b, \quad \Delta\mathbf{C} = \text{const} \quad (2)$$

where  $\Delta\mathbf{C}$  is the constant "step" of variations of **C** (in previous and our experiments  $\Delta\mathbf{C} = 5\%$  v/v).

The formation of hydrates distorts the linearity of the dependence (2) and, thus, can be revealed in this way. It was demonstrated first on the examples of complex polyfunctional synthetic drugs with sulfanylamide moiety -SO<sub>2</sub>-NH- using acetonitrile as organic modifier of an eluent [1]. The aim of our work was: **1.** to verify the existence of the same anomalies of recurrent interpretation of retention parameters for specially synthesized N-substituted series of six p-toluenesulfonamides CH<sub>3</sub>C<sub>6</sub>H<sub>4</sub>-SO<sub>2</sub>-NRR', namely, allyl, diethyl, *tert*-butyl, phenyl, benzyl, and hexyl [2]; **2.** to do this after replacing the aprotic acetonitrile by methanol containing hydroxyl group with active hydrogen atom.

## Methods:

The analytical method used in our work is reversed phase HPLC. The sets of directly measured retention times within the ranges  $55 < \mathbf{C} < 85\%$  (v/v) were processed using recurrent relation (2) with the aim to reveal any deviations from linearity, which indicate the hydrate formation. However, the recurrent dependencies (2) for all six p-toluenesulfonamides appeared to be linear with correlation coefficients  $R > 0.999$ . It does not mean the absence of hydrates, but only the low "sensitivity" of the criterion (2) to their formation.

Due to this reason we have tested another criterion for revealing the hydrate formation. It is the dependence of HPLC retention indices (in the scale of *n*-alkyl phenyl ketones), **RI**, on the concentration of the organic modifier in an eluent, **C**:

$$\text{RI} = a\mathbf{C} + b \quad (3)$$

## Results:

Recurrent dependence (2) for N-substituted p-toluenesulfonamides demonstrate the clearly visible small non-linearity if we use the acetonitrile in the eluent (Darya A. Nikitina, personal communication). However, the presence of methanol in an eluent suppresses such non-linearity. In such cases the formation of hydrates should be confirmed by the dependence of **RI**s vs. **C**. If the analytes within the all ranges of  $C_{\min} < \mathbf{C} < C_{\max}$  exist in a same (e.g., anhydrous) form, the coefficients "a" of these dependencies are rather small. However, if the equilibrium (1) influences on the ratio of anhydrous and hydrated forms of analytes within this **C**-range, the coefficients "a" become strongly negative:

$$a = d\text{RI}/d\mathbf{C} \ll 0 \quad (4)$$

## Conclusion:

The formation of hydrates of N-substituted arylsulfonamides in HPLC conditions using methanol as the organic modifier of an eluent (**C**) cannot be revealed by recurrent approximation of retention data. Instead of that another criterion on hydrate formation can be recommended: it is dependence of HPLC retention indices (**RI**) vs. **C**, namely  $\text{RI} = a\mathbf{C} + b$ ,  $a = d\text{RI}/d\mathbf{C} \ll 0$ .

## References

- [1] Zenkevich I.G., Nikitina D.A. Features of recurrent approximation of retention parameters of polyfunctional compounds in reversed phase HPLC. *J. Phys. Chem. A*. **2021**, 95, 285-293.
- [2] Kornilova T.A., Derouiche.A., Zenkevich I.G. Recurrent approximation of retention parameters as confirmation of N-substituted sulfonamides hydrate formation in reversed phase HPLC. *Analytics and Control*. **2020**, 24. 315-322.

Acknowledgements. The authors are grateful to Dr. Tatiana A. Kornilova for synthesis of p-toluenesulfonamides.

# QUANTIFICATION OF KETOSTEROIDS IN HUMAN URINE BY DISPERSIVE LIQUID-LIQUID MICROEXTRACTION AND UHPLC-Q-TOF DETECTION

*Dmitrieva E.V.*<sup>1</sup>, *Temerdashev A.Z.*<sup>1</sup>, *Azaryan A.A.*<sup>1</sup>

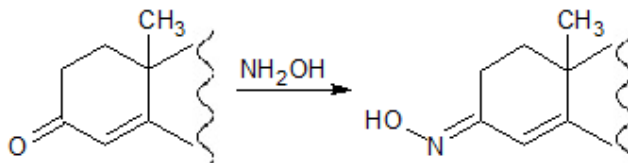
<sup>1</sup>Kuban State University, Krasnodar, Russia

Student

[catherine\\_dmitrieva@outlook.com](mailto:catherine_dmitrieva@outlook.com)

Steroid hormones act as regulators of diverse biological responses, including profound effects on cellular metabolism, development and physiology. All the steroid hormones are synthesized from the common precursor, i.e., cholesterol, via hydroxylation, oxidation and reduction reactions. Among them, estrogens, androgens, progestins, mineralocorticoids, glucocorticoids, etc., are distinguished. They participate in regulation of various vital processes such as reproduction, stress and immune response, carbohydrate metabolism and perform other important functions, therefore, their quantification is required for diagnostic purposes [1].

Steroids exert strong biological activities at very low (nanomolar and picomolar) concentrations, consequently, for their quantification in biological fluids concentration step is required. Several procedures for analytes concentration can be applied, namely, liquid-liquid extraction, solid-phase extraction, or such micro-concentration techniques as dispersive liquid-liquid microextraction [2], etc. Moreover, sensitivity may also be increased in the case of derivatization application. Among the numerous derivatization reagents, hydroxylamine seems to be one of the most promising owing to the simplicity of derivatives formation and a significant increase in sensitivity for most steroids. The reaction scheme for obtaining derivatives is given in Figure 1.



**Figure 1.** Reaction of hydroxylamine derivatives formation.

Application of enzymatic hydrolysis with  $\beta$ -glucuronidase from *E. coli* for analytes deconjugation as well as dispersive liquid-liquid microextraction followed by hydroxylamine derivatization and UHPLC-Q-ToF detection allowed to sensitively and accurately quantify steroids of various classes, namely, testosterone, dihydrotestosterone, cortisone, cortisol, progesterone, 11 $\alpha$ -hydroxyprogesterone, estrone, in human urine with the detection limits between 0.1–0.25 ng/mL.

## References

- [1] Häkkinen M.R., Murtola T., Voutilainen R., Poutanen M., Linnanen T., Koskivuori J., Lakka T., Jääskeläinen J., Auriola S. *J. Pharm. Biomed. Anal.* **2019**, 164. P. 642–652.
- [2] Dmitrieva E., Temerdashev A., Azaryan A., Gashimova E. *J. Chromatogr. B: Analyt. Technol. Biomed. Life Sci.* **2020**, 1159, 122390.

**Acknowledgements.** The innovation project was carried out with the financial support of the Kuban Science Foundation in the framework of the Commercializable scientific and innovation projects competition № NIP-20.1/4 using the scientific equipment of the Ecoanalytical center of collective usage (Kuban State University).

# A DEVELOPMENT OF A METHOD OF FREE FATTY ACIDS ANALYSIS BY A MALDI-MASS-SPECTROMETRY METHOD

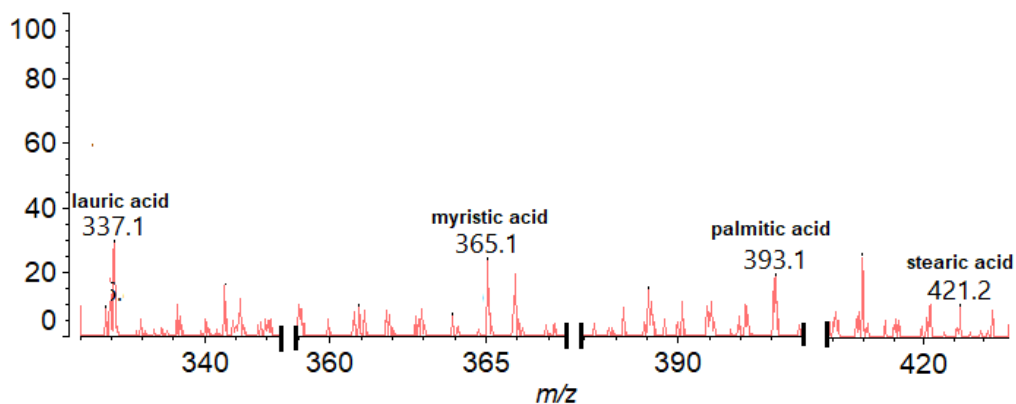
*Egorov S.S.<sup>1</sup>, Selyutin A.A.<sup>1</sup>*

<sup>1</sup>Saint Petersburg State University, Saint Petersburg, Russia  
Student  
[st076062@student.spbu.ru](mailto:st076062@student.spbu.ru)

It's currently becoming more important to analyze FFAs in both edible oils and the human body. FFAs could play role in the diagnosis and treatment of some diseases<sup>[1]</sup>. Some FFAs are also to be produced only by specific species<sup>[2]</sup>. Due to it, it could be concluded about the kinship between species.

Although the method of an analysis of FFAs by gas-chromatography is known, there are few disadvantages of this one. Firstly, the derivatization of FFAs into more volatile ether forms is required by gas-chromatography. Furthermore, at least 30 minutes are to be taken by gas-chromatography, whereas MALDI-TOF-MS takes only about 20 seconds. However, the matrix using for MALDI-TOF-MS can be chosen only by the experimental way, so it was supposed that barium<sup>[3]</sup> and hexacyanoferrates(III) mixed compounds could be used as a matrix for MALDI-TOF.

This suggestion was confirmed by the experimental way. Firstly, barium ions are to interact with FFAs forming heavy singly-charged ions detecting by mass-spectrometer. Secondly, the ionization of analytes is to be provided by hexacyanoferrates(III) ions because their maximum on the absorption spectrum conforms to the laser wavelength. The coconut oil was analyzed for FFAs' content by MALDI-TOF-MS (figure 1).



**Figure 1.** Mass-spectrum of the coconut oil.

## References

- [1] Nestel P., Clifton P., Colquhoun D., Noakes M., Mori T. A., Sullivan D., Thomas B. *Heart, Lung and Circulation* **2015**, 24, 769–779
- [2] Nancy J. Jensen, Michael L. Gross. *Mass Spectrometry Reviews* **1987**, 6, 497–536
- [3] Podolskaya E. P., Gladchuk A. S., Keltsieva O. A., Dubakova P. S., Silyavka E. S., Lukashva E., Zhukov V., Lapina N., Makhmadaliev M. R., Gzgzryan A. M., Sukhodolov N. G., Krasnov K. A., Selyutin A. A., Frolov A. *Anal. Chem.* **2019**, 91, 1636–1643

Acknowledgements. This work was supported by Russian Foundation for Basic Research (project No. 20-016-00160). The scientific research was performed at the Research park of St.Petersburg State University.

# IMPROVING APPROACH TO THE STUDY OF THE CHEMICAL STRUCTURE OF LIGNIN MACROMOLECULES BY 2D NMR SPECTROSCOPY

*Faleva A.V., Kozhevnikov A.Yu., Kosyakov D.S.*

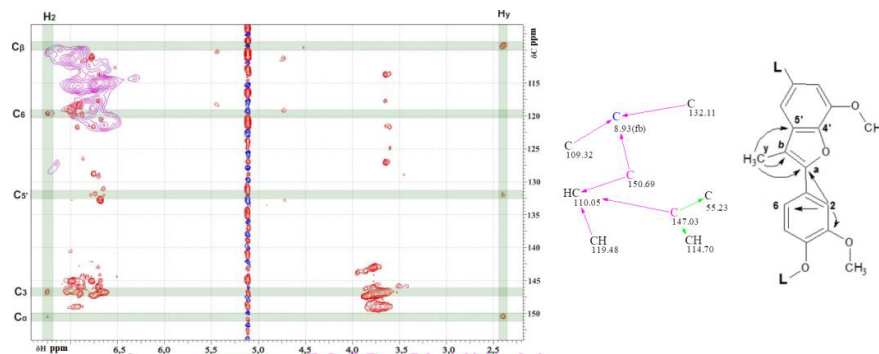
Northern (Arctic) Federal University named after M.V. Lomonosov, Arkhangelsk, Russia  
Ph.D Student  
[a.bezumova@narfu.ru](mailto:a.bezumova@narfu.ru)

Lignin is one of the most common biopolymers in the plant world, which is formed during the growth of vascular plants [1]. Despite a significant history of research in the field of lignin chemistry, its exact structure is still unclear due to significant variations in various plant tissues and species, as well as modifications in the process of chemical processing. Therefore, it is necessary to expand knowledge about the chemical structure of lignins isolated from plants of various origins, using the most informative instrumental methods for this purpose. Nuclear magnetic resonance (NMR) spectroscopy is one of the most advanced methods in the study of the structure of lignins. In particular, the 2D  $^1\text{H}$ - $^{13}\text{C}$  HSQC NMR is one of the most popular analytical tools for studying the structural features of lignin, which is reflected in a large number of articles published in this field in recent years [2]. However, the analysis of the literature data showed that the methodology of NMR spectroscopy in relation to the study of the lignin structure is not sufficiently developed. A critical step for many studies is the identification of the structural fragments that are responsible for the classification of various lignin groups. In particular, the identification problem is divided into two separate categories: 1) confirmation of the structure or identification of previously described lignin fragments; 2) identification of the structure of new lignin fragments that have not been previously reported.

In this regard, this work is aimed at improving the approach to the determination of individual structural fragments of the lignin macromolecule by NMR spectroscopy.

Based on the analysis of the  $^1\text{H}$ - $^{13}\text{C}$  HSQC spectra of various softwood lignins, the accuracy of identification of known lignin structural fragments from the literature data was evaluated and methodological recommendations were proposed. First guideline is the presence of all characteristic cross-peaks for the assumed structure. The absence of any characteristic cross-peaks casts doubt on the correctness of the identification. The second guideline is the assessment of the chemical shift. The correspondence of the experimental values of chemical shifts to the reference data should be within the range of  $\pm 0.05$  ppm for  $^1\text{H}$  and  $\pm 0.5$  ppm for  $^{13}\text{C}$ .

The use of a combination of 2D NMR experiments in conjunction with a complex of expert systems for interpreting and modeling NMR spectra (*ACD/Labs*) made it possible to assign previously unidentified cross-peaks and expand the database of chemical shifts of lignin fragments. Among them, there are mainly products of lignin degradation, as well as components of lignin preparations belonging to the classes of flavonoids and fatty acids. Two approaches were used to identify unknown cross-peaks. The first is based on the use of a database of NMR chemical shifts, taking into account the correlations present in the diagnostic NMR spectra. The second approach is to construct model spectra of the proposed fragment and compare them with experimental data.



**Figure 1.** Analysis of unknown cross-peaks and identification of a structural fragment using the ACD/Structure Elucidator Suite

## References

- [1] Liu Q., Luo L., Zheng L. *Int. J. Mol. Sci.* **2018**, *19* (2), art. no. 335.
- [2] Lupoi J.S., Singh S., Parthasarathi R., Simmons B.A., Henry R.J. *Renew. Sustain. Energy Rev.* **2015**, *49*, 871–906.

**Acknowledgements.** This work was supported by the Russian Science Foundation (project No 21-73-20275). Instrumentation of the Core Facility Center «Arktika» of Northern (Arctic) Federal University was used in this work.

# THE APPLICATION OF MAGNETIC NANOCOMPOSITES IN PIEZOELECTRIC SENSORS FOR DETERMINING POLLUTANTS IN THE ENVIRONMENT AND FOOD

*Farafonova O.V., Bizina E.V., Ermolaeva T.N.*

Lipetsk State Technical University, Lipetsk, Russia  
Senior Researcher/assistant professor, graduate student, professor  
[ov.farafonova@yandex.ru](mailto:ov.farafonova@yandex.ru)

The widespread use of pesticides and herbicides in agriculture and antibiotics for the treatment of animals poses a serious threat to human health [1]. Therefore, an urgent task is the development of methods that allow rapid detection of such contaminants with minimal laboriousness and high sensitivity. The solution to this problem can be the integration of sensor technologies into control systems. The aim of this study is to create markless piezoelectric affine sensors based on magnetic nanocomposites.

The detection sensitivity with a gravimetric piezoelectric sensor depends on the concentration and spatial availability of recognition molecules on the surface of its electrode, as well as on the mass of the layer [2]. The inclusion of a neodymium magnet in the detection cell makes it possible to form a recognition layer based on a magnetic nanocomposite under the action of magnetic forces, which makes it possible to significantly reduce the duration of the sensor preparation for analysis by 22 h and reduce the coating mass by almost 3 times.

Piezoelectric immunosensors based on magnetic carbon nanotubes for the determination of antibiotics (ciprofloxacin and penicillin G) and affinity sensors based on nanoparticles of magnetic molecularly imprinted polymers for the determination of tetracycline and the pesticide glyphosate have been developed. As a physical transducer of the sensor, we used AT-cut piezoelectric resonators with a natural vibration frequency of 10 MHz with gold electrodes 8 mm in diameter. The analytical signal was recorded on a CPNA-330 measuring device (ETNA, Russia).

Piezoelectric immunosensors used magnetic carbon nanotubes prepared in two ways: m-CNT 1 were obtained by fixing on a carbon material pre-synthesized Fe<sub>3</sub>O<sub>4</sub> magnetic nanospheres provided by the Institute for Problems of Microelectronics Technology and High-Purity Materials RAS, Chernogolovka, and in m-CNT 2 magnetic particles Fe<sub>2</sub>O<sub>3</sub> were synthesized directly on the surface of multi-walled carbon nanotubes by the modified Fenton reaction, including the reduction of iron (II) sulfate with hydrogen peroxide.

The size of magnetic nanoparticles in composites obtained by various methods has been determined by scanning electron microscopy. It was revealed that the average radius of spherical magnetic particles of m-CNT 1 is 64 ± 5 nm, while m-CNT 2 have an irregular shape and differ greatly in size (97 ± 49 nm). On the surface of the magnetic nanocomposite, a pre-synthesized antibiotic conjugate with a molecule of bovine serum albumin was immobilized. Determination of ciprofloxacin and penicillin G was performed in a competitive immunoassay format. The range of determined concentrations of penicillin G and ciprofloxacin (ng / ml) is 6 - 400/30 - 200 and 5-400 / 15-240, respectively, on m-CNT 1 / m-CNT 2.

The developed immunosensors were tested in the determination of antibiotics in milk and pork.

The conditions for the synthesis of magnetic particles of polymers with molecular imprints of tetracycline and glyphosate by the "core-shell" method have been investigated. Magnetic cores were obtained by a modified coprecipitation method, then their surface was hydrophobized with oleic acid to facilitate fixation of the polymer layer, and then a molecularly imprinted polymer "shell" was synthesized by free radical polymerization using methacrylic acid and ethylene glycol dimethacrylate.

The average radii of the magnetic cores of Fe<sub>3</sub>O<sub>4</sub> (65 ± 3 nm), magnetic particles of Fe<sub>3</sub>O<sub>4</sub> @ PMO tetracycline (93 ± 4 nm) and Fe<sub>3</sub>O<sub>4</sub> @ NIP (127 ± 6 nm) were determined, and the thickness of the surface polymer layer for Fe<sub>3</sub>O<sub>4</sub> @ PMO (28 ± 5 nm) and Fe<sub>3</sub>O<sub>4</sub> @ NIP (62 ± 8 nm). The surface concentration of molecular imprints and the stability of the recognition layer based on magnetic particles Fe<sub>3</sub>O<sub>4</sub> @ PMO tetracycline / glyphosate were determined by the method of piezoelectric microweighing. The metrological characteristics of the piezoelectric sensor for the determination of tetracycline have been established: the equation of the calibration function has been obtained, the range of the determined antibiotic contents has been determined (15 - 275 µg / ml), and the detection limit has been calculated (4.5 µg / ml) [3].

## References

- [1] Ermolaeva T., Farafonova O., Karaseva N. *Food Anal. Meth.* **2019**, *12*, 2785-2801
- [2] Farafonova OV, Shukshina EI, Grazhulene S.S., Ermolaeva T.N. *Sorption and chromatographic processes* **2017**, *4*, 548-556
- [3] Bizina E.V., Farafonova O.V., Tarasova N.V., Ermolaeva T.N. *Sorption and chromatographic processes* **2021**, *2*, 177-186

Acknowledgements. The research was funded by RFBR and Lipetsk Region, project number 20-43-480001.

HPLC AND HPLC-DETERMINATION OF POLYPHENOL-TYPE ANTIOXIDANTS IN GREEN TEA SAMPLES.  
CHARACTERISTIC PROFILES OF OBJECTS WITH A COMPLEX MATRIX.

*Fomicheva M.A.*<sup>1</sup>, *Kartsova A.A.*<sup>2</sup>, *Deev V.A.*<sup>3</sup>

Saint Petersburg State University, Saint Petersburg, Russia

Student

[4269153@mail.ru](mailto:4269153@mail.ru)

Polyphenols have antioxidant and bactericidal properties in plant samples [1]. A promising approach, along with component-by-component analysis, is to obtain their characteristic profiles in various tea samples, followed by chemometric processing to identify classification criteria and the quality of the studied objects [2].

The aim of this study is to identify polyphenol-type antioxidants in selected and commercial green tea samples with chemometric processing of the results to detect the dominant biomarkers of green tea quality. Conditions for the selective separation of polyphenolic antioxidants and caffeine by TLC, RP-HPLC with MS and UV detection were found.

The characteristic chromatographic profiles of biologically active components of green tea, including the selection profiles provided by the Institute of Floriculture and Subtropical Crops of Sochi, were obtained by HPLC and HPLC with UV and densitometric detection. Using the software "R-Studio", their chemometric processing by the principal component method was carried out, thanks to which it was possible to achieve the separation of samples into two clusters: breeding and commercial samples.

Analysis of the load schedule of the first main component revealed the dominant analytes (gallic acid, gallocatechin, caffeine, epigallocatechin gallate and epicatechin gallate) that determine the difference between the studied samples of green tea. In the selection samples, the content of polyphenols was significantly higher compared to the rest, which indicates its high quality [3].

A similar approach-obtaining characteristic chromatographic profiles of biologically active analytes with subsequent chemometric processing-has also been tested in the analysis of biological fluids in order to classify them according to the "norm" / "pathology" principle.

#### References

- [1] Gotti R., Amadesi E., Fiori J., Bosi S., Bregola V., Marotti I., Dinelli G. Differentiation of modern and ancient varieties of common wheat by quantitative capillary electrophoretic profile of phenolic acids. *Journal of Chromatography A*, **2018**, 1532, 208–215
- [2] Lazarova I., Zengin G., Gevrenova R., Nedialkov P., Aneva I., Aumeeruddy M. Z., Mahomoodally M. F. A comparative study of UHPLC/Orbitrap MS metabolomics profiles and biological properties of *Asphodeline taurica* from Bulgaria and Turkey. *Journal of Pharmaceutical and Biomedical Analysis*, **2019**, 168, 174-180
- [3] Ye Y., Yan J., Cui J., Mao S., Li M., Liao X., Tong H. Dynamic changes in amino acids, catechins, caffeine and gallic acid in green tea during withering. *Journal of Food Composition and Analysis*, **2018**, 66, 98-108

Acknowledgements. This work was carried out with the financial support of the Russian Science Foundation grant № 19-13-00370. We would like to express our gratitude to the Resource Educational Center in the field of chemistry Science Park of St. Petersburg State University for the equipment provided.

## NEW APPLICATIONS OF LABEL-FREE SILVER TRIANGULAR NANOPATES FOR DETERMINATION OF BIOLOGICALLY ACTIVE SUBSTANCES

*Furletov A.A.<sup>1</sup>, Apyari V.V.<sup>1</sup>, Garshev A.V.<sup>1,2</sup>, Dmitrienko S.G.<sup>1</sup>, Zolotov Yu.A.<sup>1,3</sup>*

<sup>1</sup>Lomonosov Moscow State University, Department of Chemistry, Moscow, Russia

<sup>2</sup>Lomonosov Moscow State University, Department of Materials Science, Moscow, Russia

<sup>3</sup>Kurnakov Institute of General and Inorganic Chemistry, Russian Academy of Sciences, Moscow, Russia  
Ph.D. student

[aleksei\\_furletov@mail.ru](mailto:aleksei_furletov@mail.ru)

Noble metal nanoparticles, in particular silver nanoparticles, are widely proposed in chemical analysis for the determination of biologically active substances with various functional groups using spectral and colorimetric methods. The most common principle of nanoparticle-based sensors' operation is their colloidal aggregation occurring for many types of nanoparticles irrespectively on their nature. A large number of papers are devoted to the synthesis and application of spherical and pseudospherical silver nanoparticles. Fewer articles discuss applications of anisotropic silver nanoparticles, in particular, silver triangular nanoplates (AgTNPs) and different composite materials based on them. The unique optical properties of AgTNPs arise from the local surface plasmon resonance (LSPR) phenomenon resulting in an intense absorption band in the visible spectral region. High molar extinction coefficients of AgTNPs and the possibility of changing the LSPR band of nanoparticles in the presence of some substances allow us to consider AgTNPs as a specific colorimetric reagent for versatile applications.

The purpose of this study was to search for new applications of label-free silver triangular nanoplates and composite materials based on them for the determination of biologically active substances by optical molecular absorption spectroscopy.

Synthesis of AgTNPs was carried out by the borohydride approach. Nanoparticles were characterized by transmission electron microscopy, electron diffraction, dynamic light scattering, and spectrophotometry. It was found that the average length of AgTNP edge is 52 nm, and the average thickness is 4 nm. AgTNPs have an intense absorption band in the range of 620 – 700 nm and dark blue color.

It was found that AgTNPs are morphologically and aggregative labile due to increased surface energy at their vertices, as well as due to the energetically favorable possibility of the plane-parallel orientation of the nanoplates relative to each other during aggregation. It was shown that changes in both the morphology and aggregative state of these nanoparticles could be used to develop new methods for the determination of biologically active substances. In the processes associated with the morphological changes of AgTNPs, it was proposed to use the value of LSPR band shift as a characteristic of the depth of interaction and as an analytical signal. In the processes associated with the aggregative changes, it was proposed to use the value of the change in the intensity of the LSPR band as an analytical signal.

The influence of pH, interaction time, and concentration of reagents on the analytical signals was assessed. Methods for the determination of oxidants (mercury (II), organic and inorganic peroxides, catecholamines and their metabolites), reducing agents (*L*-ascorbic acid, glucose, flavonoids), and organic thiols using new analytical systems based on AgTNPs have been developed. The detection limits of compounds under the selected optimal conditions are  $10^{-8}$  –  $10^{-6}$  M, the determination ranges are about an order of magnitude. The relative standard deviations of the determination results do not exceed 6 %. The proposed approaches have been successfully used for the determination of biologically active compounds in environmental objects, food additives, cosmetic preparations, medicines, and model solutions that imitate human biological fluids.

A simple sorption method for obtaining a nanocomposite material based on polyurethane foam and AgTNPs has been proposed. The possibility of using such material as a new solid-phase analytical reagent for diffuse reflection spectroscopy has been demonstrated by the example of mercury(II), peroxides, and thiols. It has been shown that an increase in the volume of the analyzed solution due to the preconcentration effect makes it possible to reduce the detection limit of biologically active compounds by a factor of 2 – 10 compared to the detection limit achieved using AgTNPs solution. Other advantages of the nanocomposite material are ease of use and the possibility of using a cheap and compact monitor calibrator for recording an analytical signal.

Acknowledgements. The reported study was funded by RFBR according to the research project № 20-33-90019.



# APPLICATION OF VANCOMYCIN TO CREATE ELECTRODICALLY ACTIVE COMPONENT (EAC) ISE MEMBRANES

*Gamzatova R.G., Tataeva S.D., Magomedov K.E.*

Dagestan State University, Makhachkala, Russia

Student

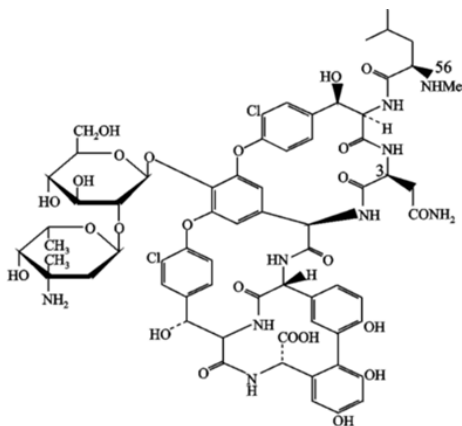
[gamzatovarayganat01@mail.ru](mailto:gamzatovarayganat01@mail.ru)

Currently, antibiotics occupy a leading place in medicine and veterinary medicine in the treatment of various infectious and inflammatory diseases and for anti-infectious prophylaxis in surgery. The widespread use of antibiotics has led to the selection and spread of resistant strains of the main pathogens. Researchers and clinicians are trying to solve this problem in the following ways: by synthesizing antibiotics of new generations, creating inhibitors of  $\beta$ -lactamases, combining already known antibiotics, creating new dosage forms and changing the dosage regimen, which, in turn, requires determining the concentration of antibiotics in various objects.

In addition to medical purposes, antibiotics are widely used to improve the quality and safety of feed, in the production of products from meat, milk, vegetables, etc. The sources of the release of antibiotics into the environment are waste water from pharmaceutical enterprises and clinics.

Consequently, the definition of antibiotics as one of the groups of medicinal compounds that have become widespread, but at the same time have a potential hazard to human health, is an urgent problem in modern clinical, analytical chemistry, veterinary medicine, pharmaceutical and food industries.

For quality control of dosage forms, it is convenient to use ion-selective electrodes [1].



**Figure 1.** Structural formula of vancomycin.

In order for ISE to be selective for only one type of ions, the membrane must contain a substance that has the ability to reversibly bind the ion to be determined and at the same time has a minimum solubility in aqueous solutions. A substance with this property is called an electrode active compound (EAC) [2].

**Purpose of the work:** to create conditions for the synthesis of an ionic associate of vancomycin and its subsequent study in the membranes of ion-selective electrodes. For this, we have set the task of studying the absorption spectra of aqueous and non-aqueous solutions of individual and mixed substances. Synthesis of an ionic associate and its electrochemical study in ISE membranes.

## References

- [1] E. G. Kulapina, O. V. Barinova. Electrochemical properties of membranes based on associates of physiologically active amines with tetraphenylborate. *Electrochemistry*, **2001**, volume 37, no. 8, p. 935-940.
- [2] S. V. Kharitonov. Ion-selective electrodes for the determination of medicinal substances. *Advances in Chemistry* **2007**, 76 (4).

EVALUATION OF THE POSSIBILITY OF TUMOR HISTOLOGICAL TYPE AND LOCALIZATION  
DIFFERENTIATION IN LUNG CANCER PATIENTS BY EXHALED BREATH COMPOSITION

*Gashimova E.M.<sup>1</sup>, Temerdashev A.Z.<sup>1</sup>, Porhanov, V.A.<sup>2</sup>, Polyakov, I.S.<sup>2</sup>, Perunov D.V.<sup>2</sup>, Osipova A.K.<sup>1</sup>*

<sup>1</sup>Kuban State University, Krasnodar, Russia

<sup>2</sup>Research Institute – Regional Clinical Hospital No.1 n.a. Prof. S.V.Ochapovsky, Krasnodar, Russia  
PhD Student

[elina.gashimova@yandex.ru](mailto:elina.gashimova@yandex.ru)

Lung cancer is the most widespread and aggressive type of oncology and it remains the leading cause of death worldwide. Diagnostics of lung cancer at early stages makes it possible significantly to increase the patient outcome. However, the symptoms of the disease are silent in early stages and early diagnosis is particularly difficult to perform. Therefore, development of express, accurate, reliable and non-invasive methodologies applicable for mass screening of lung cancer is of immense interest in a clinical context.

Diagnostics of lung cancer by using exhaled breath is a promising approach. Notwithstanding, a plethora of approaches for the lung cancer biomarkers identification in exhaled breath has been proposed, the list of putative biomarkers is wide and the lack of correlation among the results obtained by different research groups can be observed. Besides challenges relating sampling and analysis variations in different researches, confounding factors, dietary issues, coexisting conditions, it can be explained by the fact, what volatile organic compound profiles of lung cancer patients are varied depending on histological type of tumor and its localization.

This research is devoted to the investigation of volatile organic compound profiles of 80 lung cancer patients with different histological types (adenocarcinoma, squamous cell carcinoma and small cell carcinoma) and tumor localization (central and peripheral) with the aim to find differences and evaluate the possibility to classify the samples by using exhaled breath volatile organic compound profiles.

Statistically significant difference depending on tumor localization was found for 1-pentanol and some volatile organic compound ratios. In case of histological types statistically significant differences were observed for some volatile organic compound ratios.

Acknowledgements. This work was supported by Russian Ministry of Science and Higher Education (project no. FZEN-2020-0022) and the Russian Foundation for Basic Research (project no. 20-33-90033) and carried out using the scientific equipment of the Center for Environmental Analysis at the Kuban State University (unique identifier RFMEFI59317X0008).

# DETERMINATION OF TRICYCLIC ANTIDEPRESSANTS BY IMMUNOSENSORS BASED ON HYBRID NANOSTRUCTURES IN THE SEQUENTIAL INJECTION ANALYSIS MODE

*Gazizullina E.R., Brusnitsyn D.V., Medyantseva E.P.*

A.M. Butlerov Institute of Chemistry, Kazan Federal University, Kazan, Russian Federation  
PhD student  
[elvina1704@yandex.ru](mailto:elvina1704@yandex.ru)

Prescribing tricyclic antidepressants to patients is associated with their effectiveness in the treatment of depressive disorders, neurosis, panic and other anxiety conditions, but these drugs can't be taken without the supervision of a doctor, because there is a risk of overdose, causing side effects.

Increasing the sensitivity and selectivity of biosensors is possible by modifying their surface with various nanostructured materials, including carbon and metal nanostructures. In this case, both enzymes and antibodies can act as biosensitive components.

In the development of methods for the determination of medicinal compounds, along with various types of chromatography and physico-chemical research methods, flow methods, including sequential injection analysis, are used as a method of automation. Flow analyzers have advantages such as high performance, minimal sample consumption, and ease of use.

In the flow system, various detection methods are used. Among them, voltammetric detectors are more sensitive and less expensive.

Thus, the use of voltammetric immunosensors in the mode of sequential injection analysis for monitoring these drug compounds in the biological materials of patients is an urgent task.

Voltammetric immunosensors based on screen-printed graphite electrodes modified with reduced graphene oxide in an amino derivative on the platform of polyether polyol of second generation and cyanide chalcogenide hexarenum cluster complexes and reduced graphene oxide in chitosan and cyanide chalcogenide hexarenum cluster complexes for sequential injection determination of tricyclic antidepressants (amitriptyline, imipramine, desipramine).

According to the electrochemical impedance spectroscopy data, hybrid nanomaterials with the lowest electron transfer resistance (combinations of hexarenum cluster complexes with reduced graphene oxide in polyether polyol and with reduced graphene oxide in chitosan) were selected and used as biosensor modifiers. In the course of studying the electrochemical behavior of the rhenium cyanide nanocluster, it was found that the voltammogram shows peaks from the electrochemical oxidation of the cluster complex. The addition of reduced graphene oxide into the composition of the modifier increases the oxidation current of the rhenium cluster by 4 times. Modification of the surface of the transducer as the basis of the sensor by various nanomaterials contributes to both the formation of a stable analytical signal and its significant amplification.

As a biosensitive component, antibodies against tricyclic antidepressants were used. The interaction of antibodies with the antigen is manifested in a decrease in the oxidation current of the cluster complex on the differential pulse voltammogram due to an increase in resistance and the formation of an antigen-antibody complex on the electrode surface.

The optimal conditions for the applicability of immunosensors in the mode of sequential injection analysis were selected. The range of working concentrations of the best voltammetric immunosensor in the sequential injection analysis mode is  $1 \times 10^{-5} - 1 \times 10^{-10}$  mol/l with the lower limits of the determined contents at the level of  $5 \times 10^{-11}$  mol/l. At the same time, there is an increase in the sensitivity of immunosensors in the flow in comparison with immunosensors in the stationary mode.

Methods of sequential injection determination of tricyclic antidepressants by immunosensors against the background of model urine with an error of no more than 0.041 were developed.

## PREPARATION OF LIQUID PRODUCTS OF HEAT TREATMENT OF RUBBER WASTE

*Genarova T.N.<sup>1</sup>, Leshchev S.M.<sup>2</sup>*

<sup>1</sup>SNU "A.V. Luikov Institute of Heat and Mass Transfer National Academy of Sciences of Belarus" PhD

<sup>2</sup>Belarusian State University

[genarovataty@gmail.com](mailto:genarovataty@gmail.com)

Carrying out a reliable analysis of liquid products of industrial rubber waste heat treatment is a rather difficult task. Despite the fact that there is a huge number of works related to the study of pyrolysis products, very few works are devoted to methods of extraction separation of the components of the pyrolysis mixture.

The chromatographic distribution method for the analysis of organic acids and bases in pyrolysis water made it possible to additionally not only confirm, but also clarify the results of its chemical composition, and also to determine that some chromatogram peaks contain impurities of unknown nature and may overlap each other. The use of molecular and dissociative extraction of the components of pyrolysis water, as follows from the results obtained, makes it possible to increase the reliability and accuracy of determining its chemical composition.

A method of extraction sample preparation of pyrolysis oil based on the stepwise extraction of components from pyrolysis oil with water, ethylene glycol (EG), dimethyl sulfoxide (DMSO) and oleum was proposed, which made it possible to conduct a more reliable analysis of the component composition of pyrolysis oil by the GC-MS method. It has been shown that the chromatography-distribution method for the analysis of pyrolysis oil, including the sequential selective extraction of classes of compounds from pyrolysis oils by a number of solvents and reagents that differ in polarity, followed by GC-MS analysis of the extracts, is a promising method for studying liquid products from the processing of used automobile tires.

Thus, extraction with water, an aqueous acid solution and an aqueous alkali solution made it possible to extract hydrophilic organic bases and acids. The EG extract did not contain significant amounts of moderately hydrophobic compounds, except for benzothiazole. The use of DMSO made it possible to extract condensed multinuclear aromatic hydrocarbons from the pyrolysis oil, and the oleum removed unsaturated and aromatic hydrocarbons from the hexane solution of the pyrolysis oil.

The results obtained in this work are of undoubted importance for the chemistry of pyrolysis of organic compounds, in particular, from the results obtained it can be seen that the pyrolysis of rubber products is accompanied by both the obvious formation of the most stable aromatic hydrocarbons at high temperatures, and the formation of aliphatic and naphthenic hydrocarbons established in the work. At the same time, the presence of noticeable amounts of aliphatic and naphthenic hydrocarbons in pyrolysis oils has not, as a rule, been established in the literature before this study.

# TIME-RESOLVED POLARIZED FLUORESCENCE OF ALCOHOL DEHYDROGENASE-NADH BINARY COMPLEX IN SOLUTION UPON TWO-PHOTON EXCITATION BY FEMTOSECOND LASER PULSES

Gorbunova I.A.<sup>1</sup>, Sasin M.E., Golyshev D.P.<sup>1,2</sup>, Semenov A.A.<sup>1</sup>, Beltukov Y.M.<sup>1</sup>, Vasyutinskii O.S.<sup>1</sup>

<sup>1</sup>Ioffe Institute, Saint Petersburg, Russia

<sup>2</sup>Peter the Great St.Petersburg Polytechnic University, Saint Petersburg, Russia

PhD Student

[i.gorbunova@mail.ioffe.ru](mailto:i.gorbunova@mail.ioffe.ru)

During latest decades cell diagnostic methods based on monitoring of time-resolved autofluorescence of endogenous fluorophores upon excitation by ultrafast laser pulses were actively developed. [1]. An important endogenous fluorophore is reduced nicotinamide adenine dinucleotide (NADH) that can be found in almost all cellular compartments and plays an essential role in regulation of redox reactions in living cells. As known NADH exists in living cells in free and enzyme-bound forms, as pointed out by Chance et al. [2] the relative concentration of the forms can be used for monitoring of the changes in cellular metabolism. As known, fluorescence decay kinetics in free NADH in solution can be characterized with two fluorescence decay times lying in the sub-ns range. [3] The results of recent publications suggested that these decay times relate to cis- and trans- configurations of the nicotinamide ring. [3] In turn, protein-bound NADH in solution exhibited multiexponential fluorescence decay with a short decay time  $\tau_1 = 120$  ps [4] and long decay time of  $\tau_2 = 1 - 6$  ns that depended on microenvironmental conditions [4]. Despite many efforts of understanding the origin of the shorter exponential it still remains controversial. We investigated time-resolved polarized fluorescence of NADH-ADH complexes in PBS solution upon two-photon excitation at 720 nm. The fluorescence signals were analysed based on a model taking into account contribution from free and protein-bound NADH. The set of the isotropic and anisotropic decay parameters related to free and bound NADH were determined from experiment and compared with results of the previous studies.

Measurement of two-photon excited polarized fluorescence signals was performed within a standard experimental procedure described in our previous publication [3]. The experimental sample was two-photon excited at 720 nm by femtosecond laser pulses. Polarized fluorescence was collected at the right angle to the laser beam propagation. The spectral range of the detected fluorescence was selected by a set of dichroic filters with the bandwidth of 425 - 445 nm installed after the cuvette. Two orthogonally polarized fluorescence components parallel  $I_{\parallel}(t)$  and orthogonal  $I_{\perp}(t)$  to the laser beam polarization were separated by a Glan prism and then independently detected by two fast photon counting photodetectors. The recorded signals were analyzed by a time correlated single photon counting (TCSPC) system. Processing of the experimental signals was carried out by a global fit procedure using a maximum likelihood estimation for the Poisson distribution.

In the result of analysis of fluorescence decay signals it was found that the ADH-bound NADH is characterised by two decay times:  $\tau_1$  of about 0.1 ns and  $\tau_4$  of about 4.5 ns. The fluorescence decay time of  $\tau_4 = 4.5$  ns associated with bound NADH is several times larger than the fluorescence decay times  $\tau_{f1} = 0.24$  ns and  $\tau_{f2} = 0.66$  ns in free NADH. The value of fluorescence decay time related to bound NADH is in a good agreement with one of the fluorescence decay times in NADH bound with ADH reported elsewhere [4]. We believe that a significant increase of the decay time in bound NADH is due to apolar binding site in ADH [4]. The existence of the short decay time  $\tau_1 \approx 0.1$  ns in enzyme-bound NADH was associated with fast non-radiative relaxation process. A new feature of the polarized fluorescence decay in NADH was the anisotropic decay time  $\tau_{bv} = 0.89$  ns in the enzyme-bound NADH. This anisotropic decay time can be explained by anisotropic vibrational relaxation in excited states that results in rotation of the NADH transition dipole moment due to rearrangement of nuclear configuration. The existence of the anisotropic vibrational relaxation time  $\tau_{bv}$  is very important because it depends on the enzyme binding site environment and can be used together with other decay times for characterization of the NADH binding processes with dehydrogenases.

## References

- [1] Vishwasrao, H. D., Heikal, A. A., Kasischke, K. A., and Webb, W. W. *J. Biol. Chem.* **2005**, 280 (26), 25119–25126.
- [2] Chance, B., Schoener, B., Oshino, R., Itshak, F. and Nakase, Y. *J. Biol. Chem.* **1979**, 254, 4764–4771.
- [3] Gorbunova, I. A., Sasin, M. E., Rubayo-Soneira, J., Smolin, A. G., and Vasyutinskii, O. S. *J. Phys. Chem. B.* **2020**, 124(47), 10682–10697.
- [4] Piersma, S. R., Visser, A. J. W. G., de Vries, S., and Duine, J. A. *Biochemistry* **1998**, 37(9), 3068–3077.

Acknowledgements. This work was supported by the Russian Foundation for Basic Research (18-53-3400) and BASIS Foundation for financial support (19-1-1-13-1).

# USE OF DIGITAL COLOR ANALYSIS FOR STUDYING PEN INKS AGING UNDER UV IRRADIATION WITH THEIR FURTHER CLASSIFICATION

*Gryazev I.P., Kalinichev A.V., Peshkova M.A.*

Saint Petersburg State University, Saint Petersburg, Russia

Student

[iv.gryazev@gmail.com](mailto:iv.gryazev@gmail.com)

The dating of handwritten documents is an important step in the process of determining whether they have been falsified or illegally edited. One can obtain this information by analyzing the pen ink composition. Classic pen inks consist of 50% solvent, 25% dye, and 25% thickener/binder. Most modern methods such as chromatography, mass spectrometry, Raman spectroscopy are based on quantitative analysis of each of these components. However, all of these methods are bulky and expensive for routine use.

In turn, the method of digital color analysis (DCA) has become widespread in the fields of analytical chemistry and document analysis. DCA is easy to utilize and it requires inexpensive equipment such as a simple digital camera or even a smartphone. In this work, a new method of classification of writing inks and investigation of their aging using DCA is presented [1]. The approach relies on the assumption that all significant changes in the composition and properties of an ink sample are reflected in its color change upon aging (Figure 1).

Here, we simulated aging of ballpoint pen inks by exposure to UV light for 72 hours. During this time the ink color was captured by photography. After DCA, the kinetic curves (color signal vs. UV irradiation time) were further processed using hierarchical cluster analysis. The proposed method was utilized to classify 4 different pens. The obtained results allowed us to isolate 3 separate clusters. To validate the developed approach, the method of Raman spectroscopy was implemented. It was shown that the proposed method was more informative in terms of number of clusters than Raman spectroscopy. In addition, the effect of sample storage temperature and type of paper on the classification results was investigated.

As a result, the method of digital color analysis has proven to be an effective low-cost method for studying ballpoint pen inks and their classification. Further investigation of the obtained ink aging curves paves the way for an affordable and precise method for signature and document dating.

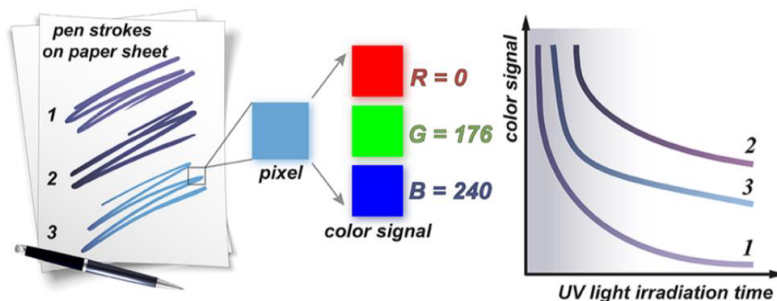


Figure 1. Color research scheme [1].

## References

- [1] Tiuftiakov, N. Y. et al. *Anal. Chem.* 2021, 93, 5015–5019.

Acknowledgements. This work was supported by the Russian Science Foundation (project No 20-73-10033).

## DETERMINATION OF FLUORINE COMPOSITION BY GAS CHROMATOGRAPHY

*Iakhina D.N.*<sup>1</sup>, *Pashkevich D.S.*<sup>2</sup>, *Belov N.A.*<sup>1</sup>, *Ivanov A.A.*<sup>1</sup>, *Andreev A.A.*<sup>1</sup>, *Shagalov V.V.*<sup>1</sup>,  
*Kambur P.S.*<sup>1</sup>, *Kapustin V.V.*<sup>2</sup>, *Bryankin D.V.*<sup>1</sup>

<sup>1</sup>Tomsk Polytechnic University, Tomsk, Russia

<sup>2</sup>Peter the Great St. Petersburg Polytechnic University, St. Petersburg, Russia  
Postgraduate student, 3rd year

[yahina@tpu.ru](mailto:yahina@tpu.ru)

In modern industry, elemental fluorine is produced by electrolysis of KF·2HF melt in an electrolytic cell with a graphite anode. Manufacturers use different methods for determining fluorine gas composition. So at Siberian Chemical Combine fluorine is analyzed by a titrimetric method to determine the content of the basic substance. At the Russian Research Center Applied Chemistry the anode gas is analyzed by carrying out a solid-phase reaction of fluorine substitution with sodium chloride, the amount of fluorine is judged by the absorption of chlorine released during the reaction by potassium iodide (KI), the absorption method is also used to determine the content of CO<sub>2</sub> and O<sub>2</sub>. It is known that the main components of the anode gas are fluorine, hydrogen fluoride, nitrogen, oxygen, carbon dioxide, carbon tetrafluoride; carbon monoxide and sulfur hexafluoride also may be present. It is necessary to know the anode gas composition for the development of methods for obtaining pure fluorine, which is required in excimer lasers and some other applications.

The authors have developed a method for analyzing the anode gas composition by gas chromatography.

In this method, at the first stage, the concentration of hydrogen fluoride in the anode gas is determined by passing a known amount through a vessel with sodium fluoride at room temperature to obtain NaF·HF. The equilibrium pressure of HF over NaF·HF in this case is 0.054 kPa [1] and, therefore, almost all of the hydrogen fluoride is bound. Other components of the gas mixture do not react with NaF and NaF·HF. Determination of HF is carried out by titration of the resulting salt with NaOH solution.

At the second stage, the gas stream, purified from HF, is directed to a vessel with KI, where KF and I<sub>2</sub> are formed upon interaction with fluorine. To determine the amount of passed fluorine, a mixture of potassium fluoride and iodine is dissolved in water and titrated with sodium thiosulfate solution. KI is used with a water content of 0.5 wt% to ensure quantitative fixation of fluorine on KI at room temperature. When fluorine interacts with water, oxygen and hydrogen fluoride is released, which interacts with potassium iodide in the presence of oxygen. The amount of oxygen released is analyzed by thermogravimetry measuring the moisture content of potassium iodide.

At the third stage, the gas stream, purified from HF and F<sub>2</sub>, is sent to a gas chromatograph to determine the content of nitrogen, oxygen, carbon dioxide, carbon tetrafluoride and other substances.

Gas chromatography was performed on a Crystallux-4000M gas chromatograph (RPC "Meta-chrom", Yoshkar-Ola, Russia) with a thermal conductivity detector. A 1-ml gas sample was injected by loop injection system onto packed columns (HayeSep Q, 3 m×2 mm I.D., 80/100 mesh packing size; NaX, 3 m×3 mm I.D., 60/80 mesh packing size). An Agilent HayeSep Q column was chosen for the analysis of oxygen and nitrogen, and a NaX column was chosen for the separation and determination of the other components of the gas mixture.

Fluorine was obtained in a laboratory electrolyzer, the anode material is a carbon electrode, the cathode is the nickel body of the electrolyzer. Potassium bifluoride is used as the electrolyte. The current of electrolyzer power supply system is varied in the range of 0-100 A, usually the amperage is maintained in the range of 10-40 A, the voltage is up to 10 V.

As a result, it was shown that the previously listed substances are present in the anode gas. According to the results of the fluorine titrimetric analysis, it was determined that from the beginning of the electrolyzer operation until the end of the experiments (the electrolyzer operation time was 9 hours), the fluorine content in the anode gas increases from 74% to 92%. At the same time, the change in the oxygen content in the anode gas decreases with a decrease in the concentration of water in the electrolyte from 11.2% (the beginning of the operation of the electrolyzer) to 0.5% (after 8 hours of the operation of the electrolyzer), the CF<sub>4</sub> content changes from 0.02% to 0.2 %, CO<sub>2</sub> - from 1.3% to 3%. The error in the determination of these components by gas chromatography is 5-7%.

### References

[1] Ryss I.G. *Chemistry of fluorine and its inorganic compounds*. 1956.

Acknowledgements. This work was supported by Ministry of Science and Higher Education of Russian Federation, project FSWW-2020-0020.

EFFICIENCY OF THE SORBENT «FLORISIL» FOR SOLID-PHASE EXTRACTION  
OF VISCOUS ADDITIVES BASED ON POLYALKYLMETHACRYLATE

*Ivanova Yu.A., Kiseleva N.V., Makhotkina D.A.*

Kuban State University, 350040, Russian Federation,  
Krasnodar, Stavropol'skaya street, 149  
[uyliu@mail.ru](mailto:uyliu@mail.ru)

The viscosity-temperature characteristics of a lubricating oil are the defining indicators of its quality. To improve them, special additives are introduced - viscous additives. This requires an assessment of the state of functional additives in lubricating oils, consisting of a base oil and functional additives. To determine viscous additives, their preliminary extraction from the lubricant is required. For these purposes, SPE is widely used. Additives based on polyalkylmethacrylate are currently used to increase viscosity and improve viscosity-temperature characteristics. They are weakly polar high molecular weight substances; therefore, the most commonly used sorbents based on unmodified silica gel are ineffective for their extraction from the oil base.

The aim of this study was to study sorption materials based on modified silica gel for solid-phase extraction of viscous additives based on polyalkylmethacrylate from lubricants for their subsequent chromatographic determination. The possibility of using various sorbents for extracting viscous additives from a lubricant is determined by their sorption characteristics - "volume before breakthrough", retained volume and the degree of recovery, which can be determined from the output dynamic sorption curve. The studies were carried out using a sorbent based on silica gel modified with magnesium oxide (Florisil). The extracts were analyzed by gel permeation chromatography with refractometric detection. "Volumes before breakthrough" were calculated for viscous additives "Maxoil V" and PMAD, they were 1.4 and 1 cm<sup>3</sup>, respectively, using hexane as a solvent. It was shown that acetone is the optimal eluent that ensures the completeness of the extraction of viscous additives from the sorbent. The recovery of analytes was 65 and 98%, respectively, with an acetone eluent volume of 2.5 cm<sup>3</sup>.

Based on the studies carried out, the efficiency of using a sorbent based on silica gel modified with magnesium oxide for the extraction of viscous additives based on polyalkylmethacrylate from the base of lubricants was evaluated. The main sorption characteristics of the sorbent with respect to commercial viscous additives dissolved in solvents of different polarities were studied, the number of theoretical plates was calculated with respect to commercial polymer additives "Maxoil V" and PMAD.

The research was carried out within the framework of the RFBR grant (No. 19-33-90175) using the scientific equipment of the Center for Collective Use "Ecological Analytical Center" of the Kuban State University



DEVELOPMENT OF APPROACHES FOR OBTAINING THE CHROMATOGRAPHIC PROFILES OF POLYPHENOLS AND AMINOACIDS OF BIOTECHNOLOGICAL *IRIS SIBIRICA L.* RAW PLANT MATERIAL

*Karpitskiy D.A., Bessonova E.A., Kartsova L.A.*

St. Petersburg State University Institute of Chemistry, Saint Petersburg, Russia

Student

[karpitskyda@mail.ru](mailto:karpitskyda@mail.ru)

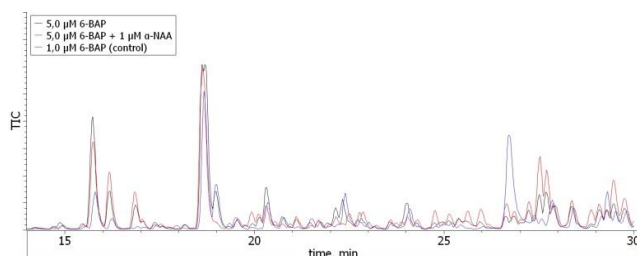
Plants of the *Iris* group are widely used in traditional medicine to fight bacterial and viral infections, as well as an antispasmodic, hemostatic or laxative. The substances isolated from *Iris*es have antibacterial, antiviral, anti-inflammatory, antioxidant and cytotoxic activity. The main active components are phenolic compounds, namely flavonoid or isoflavonoid aglycones and their corresponding glycosides, triterpenoids, amino acids. A promising direction for obtaining medicinal plants is the use of biotechnological approaches that allow to obtaining high-quality medical raw materials and regulating its phytochemical composition. However, there are no suitable methods for its qualitative and quantitative analysis as well as quality control.

*Iris sibirica L.*, a species of the *Iris* group, is mainly distributed in the south and west of Russia. Biotechnological plant biomass of *Iris sibirica L.*, is a valuable and poorly studied medical raw material. A comprehensive phytochemical study of this raw plant material is required to obtain as many individual characteristics as possible. It needs the development of analytical approaches for optimize biotechnology and effective control the quality of the raw materials produced by various indicators. This will provide to obtain characteristic chromatographic profiles of the plant.

The purpose of this study is to obtain chromatographic profiles of flavonoids and amino acids of biotechnological raw materials *Iris sibirica L.* and to reveal regularities of its changes depending on the hormonal composition of the nutrient medium. The HPLC method coupled with diode-array detection (DAD) and tandem mass spectrometry with electrospray ionization in positive and negative ion modes, was developed and applied for the determination of polyphenols and amino acids in the *Iris sibirica L.* The determination of amino acids by HPLC was carried out using preliminary derivatization with dansyl chloride.

The design of experiments was constructed in order to select and optimize the conditions for the effectively extraction of the determined biologically active substances. The conditions were selected under which the extraction of target analytes reaches a maximum. It was revealed that the most significant factors affecting the extraction of phenolic compounds were the methanol content and the combined effect of the temperature and heating time. For amino acids, these were the extraction temperature and the concentration of methanol in the extractant.

The characteristic profiles of phenolic compounds and amino acids of biotechnological *Iris sibirica L.* grown on nutrient media with different phytohormones (cytokinin and auxin) concentration were obtained and investigated the changes in their composition. The main metabolites have been identified for the control of biotechnological raw materials. The concentrations of most amino acids increases significantly with the addition auxin. Preliminary results also confirmed the enhancement of the action of hormones when they used together.



**Figure 1.** Influence of auxin ( $\alpha$ -NAA) additives on polyphenol profile of *Iris sibirica L.* by RP HPLC-MS.

Acknowledgements. This work was supported by the Russian Science Foundation (project No 19-13-00370). Authors thank Chemical Analysis and Materials Research Centre and Centre for Molecular and Cell Technologies of the St. Petersburg State University Science Park for technical support.

## OXYGEN IN MELTS OF LITHIUM AND BERYLLIUM FLUORIDE SALTS

*Kartashova E.S.<sup>1</sup>, Danilov D.A.<sup>1</sup>, Polovov I.B.<sup>1</sup>*

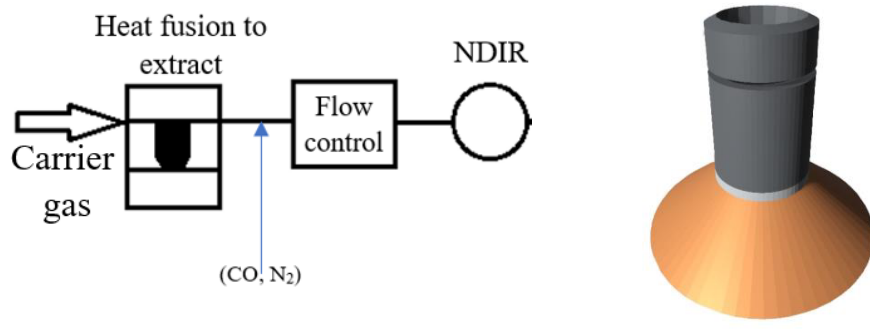
<sup>1</sup>Ural Federal University, Ekaterinburg, Russia

Student

[k543lena5@yandex.ru](mailto:k543lena5@yandex.ru)

Currently, there is an accelerated development in the field of nuclear energy since this direction is the most promising for obtaining an almost inexhaustible source of energy. This energy resource is the most profitable, since it is an environmentally friendly way to create energy and when burning, the consumption of nuclear fuel is low. Straight to achieving this goal, there is a specific task – the creation of a closed nuclear fuel cycle, in which it is necessary to constantly manage intra-system processes. Here there are molten salt reactors, in which the core is formed by a mixture of melts of fluoride salts of light elements (sodium, potassium, lithium, beryllium) and fluorides of fissile materials [1-2].

U and Th have good solubility in melts of light metal fluoride salts, such as FLiNaK and FLiBe. However, there are certain difficulties in using these salts. In spite of that FLiBe is a fairly stable system, it is able to react with oxygen, forming oxides and oxy-fluorides of the elements that make up the salt. As a result, the permanence and sluggishness of the salt is reduced. Its corrosion activity increases with in relation to the reactor materials [3]. So the analytical control of the oxygen content in the melts of FLiNaK and FLiBe is very important.



**Figure 1.** Principle diagram of the oxygen analyzer, crucible model with cap

The oxygen content can be determined in several ways, of which Carrier Gas Hot Extraction is the most promising. The method is based on the release of oxygen from the sample under the influence of high temperatures  $\approx 2500\text{-}3000\text{ C}$ . It then interacts with the carbon of the crucible and forms carbon monoxide (CO), which is transported by the carrier gas (Ar), to the detection region. The IR detector is tuned to the CO wavelength (**Figure 1**).

For the analysis, we used Horiba EMGA620W. The finely ground molten salt was mixed with SiC for an hour. The derived sample weight was placed in tin capsules and sealed. All stages were carried out in an inert atmosphere.

The graphite crucible with the cap was devolatilised twice (the first time at a temperature of 7kW, the second time-6kW). Then a tin capsule with a sample was manually placed under the graphite lid and analyzed at a temperature of 6kW.

The graphite cap allowed us to solve two main problems of applying the method to this system:

1. mechanical spraying of oxygen-containing compounds during intensive boiling of a mixture of fluorides;
2. loss of fugitive oxygen-containing compounds ( $\text{BeF}_2\text{O}$ ,  $\text{Be}_2\text{O}$ ).

Due to the lack of standard samples of the oxygen content in the FLiBe, the correctness and precision of the method was established by the methods of additives, dilution, and variation of the sample weight.

### References

- [1] Beckman I. N. Radiochemistry in 2 volumes. Volume 2 Applied radiochemistry and radiation safety. - M.: Yurayt, 2020. - p. 10-105
- [2] Everything you wanted to know about the liquid salt reactor // ROSATOM Country URL: <https://strana-rosatom.ru/2020/09/21/vse-chto-vy-hoteli-znat-o-zhidkosolevom/> (accessed 05.05.2021).
- [3] Blinkin V. L. Zhidkosolevye nuclear reactors / V. L. Blinkin, V. M. Novikov-M.: Atomizdat, 1978 - p 112

SUPRAMOLECULAR SOLVENT-BASED MICROEXTRACTION OF ADRENALINE FOR ITS  
DETERMINATION BY HIGH-PERFORMANCE LIQUID CHROMATOGRAPHY  
WITH FLUORESCENCE DETECTION

*Kasper S.V., Vakh Ch.S.*

St.Petersburg State University, Saint Petersburg, Russia  
Student  
[svetlana.kasper@mail.ru](mailto:svetlana.kasper@mail.ru)

Adrenaline is a hormone of the adrenal glands, which is normally secreted in stressful situations, with injuries and enhanced muscle load. An increase in its concentration in urine and blood plasma can serve as a biomarker for the diagnosis of adrenal glands neoplastic diseases in the early stages. Adrenaline-based pharmaceuticals are used in cases of breathing difficulties, to relieve local anesthetics, and in other cases. Therefore, methods for quantitative determination of adrenaline are required in both pharmaceutical analysis and medical diagnostics.

Supramolecular solvents are nanostructured systems formed in colloidal solutions of amphiphilic compounds as a result of self-organization and coacervation phenomena. When the concentration of amphiphile in solution becomes higher than the critical micelle concentration, the process of self-organization begins, in which amphiphile molecules are combined into three-dimensional aggregates, for example, into micelles or vesicles. After that, conditions are created in the system that causes the aggregates to combine into larger particles - coacervates and drops. They eventually separate from the colloidal solution and form a new liquid phase, which is rich in amphiphiles and does not mix with water [1-2].

For the determination of adrenaline in biological fluids and pharmaceuticals the supramolecular solvent-based microextraction followed with high-performance liquid chromatography with fluorescence detection (HPLC-FL) has been developed. For this, nonionic surfactants and medium chain fatty acid as well as derivation of the adrenaline with o-phenylenediamine [3] were utilized. Several parameter affected to the efficiency of the analyte determination have been optimized. Among them: concentration of o-phenylenediamine, type and volume of nonionic surfactant, type and volume of medium chain fatty acid. Under optimal condition the linear range was  $3 \cdot 10^{-9}$ - $3 \cdot 10^{-6}$  mol L<sup>-1</sup> and limit of detection was  $5,4 \cdot 10^{-10}$  mol L<sup>-1</sup>. Relative standard deviation did not exceed  $7 \pm 1\%$ . The developed approach was implemented for the determination of adrenaline in real urine samples and pharmaceuticals.

#### References

- [1] *Analytical and Bioanalytical Chemistry* **2020**, 412, 6037–58
- [2] *Chromatographia* **2018**, 82, 111–24
- [3] *Analytica Chimica Acta* **1998**, 363, 105–10.

Acknowledgements. This work was supported by Russian Science Foundation (research projects No. 21-73-00035, <https://rscf.ru/project/21-73-00035/>)

# FEATURES OF SAMPLE PREPARATION OF BALL PEN INK AFFECTING THE EFFICIENCY OF DYES EXTRACTION FOR THE FOLLOWING ANALYSIS BY HPLC

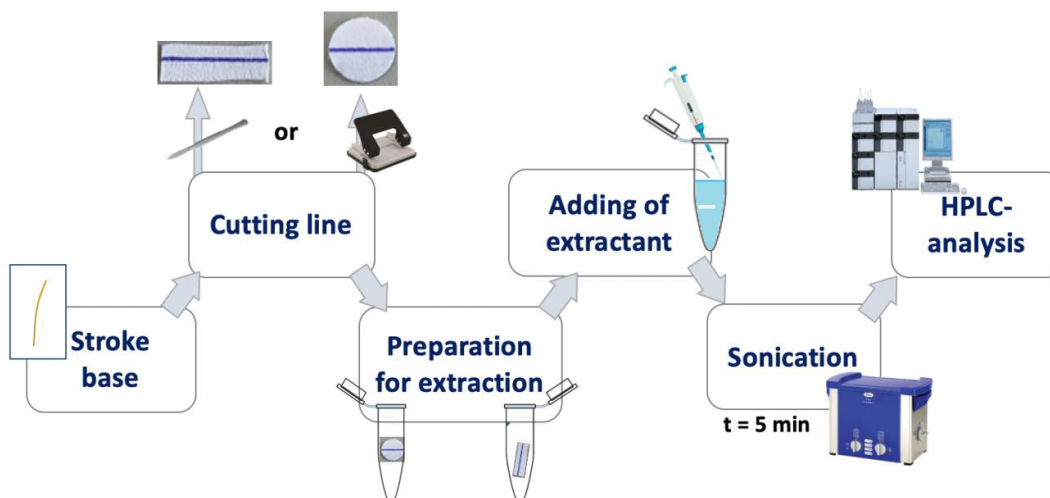
*Kechin A.A., Kravchenko A.V., Kartsova L.A.*

Saint Petersburg State University, Saint Petersburg, Russia

Student

[kechin.ars@icloud.com](mailto:kechin.ars@icloud.com)

Document verification is one of the most important tasks of the Forensic Document Examination (FDE). Comparison of the qualitative and quantitative analysis of ink taken from different parts of the document allows to suppose whether part of the text was added or forged. Another important task of FDE is determination of the limitation period, which requires the use of methods capable of providing high accuracy and reproducibility of analyzes. The use of high-performance liquid chromatography (HPLC) for these purposes seems promising [1]. There is a fundamental difficulty in ink analyzing. It contains a large number of components. They include dyes and pigments dissolved in one or more solvents, resins, and other compounds that may be added to change the properties of ink [2]. Therefore, it is important to perform the sample preparation before analysis. During sample preparation, matrix effects can be eliminated and target components can be isolated for further analysis (Fig. 1).



**Figure 1.** Sample preparation scheme for the extraction of coloring components from ink applied to paper.

Thus, the aim of the study was to develop an effective approach to a sample preparation of a line of blue ballpoint pen ink on paper to the following HPLC analyze. Efficiency of various solvents in the extraction of ink was studied by comparing the values of the dye peak areas. The latter was obtained as a result of the HPLC analysis. To study the reproducibility and choose the way of sample preparation, five samples of pen ink were cut out using both a hole punch and a scalpel.

## References

- [1] *Vibrational Spectroscopy*, **2006**, 40(2), 270-277.
- [2] *Forensic Science International*, **2010**, 197 (1-3), 1-20.

This work was carried out with the financial support of the Russian Science Foundation grant No. 19-13-00370 using the equipment of the Resource Center "Methods of analysis of the composition of matter" of the Science Park of St. Petersburg State University.

# THE PARADOX OF THE NON-CONSTANCY OF THE BULK RESISTANCE OF ION-SELECTIVE ELECTRODE MEMBRANES WITHIN THE NERNSTIAN RESPONSE RANGE

*Keresten V.M., Mikhelson K.N.*

Saint Petersburg State University, Saint Petersburg, Russia

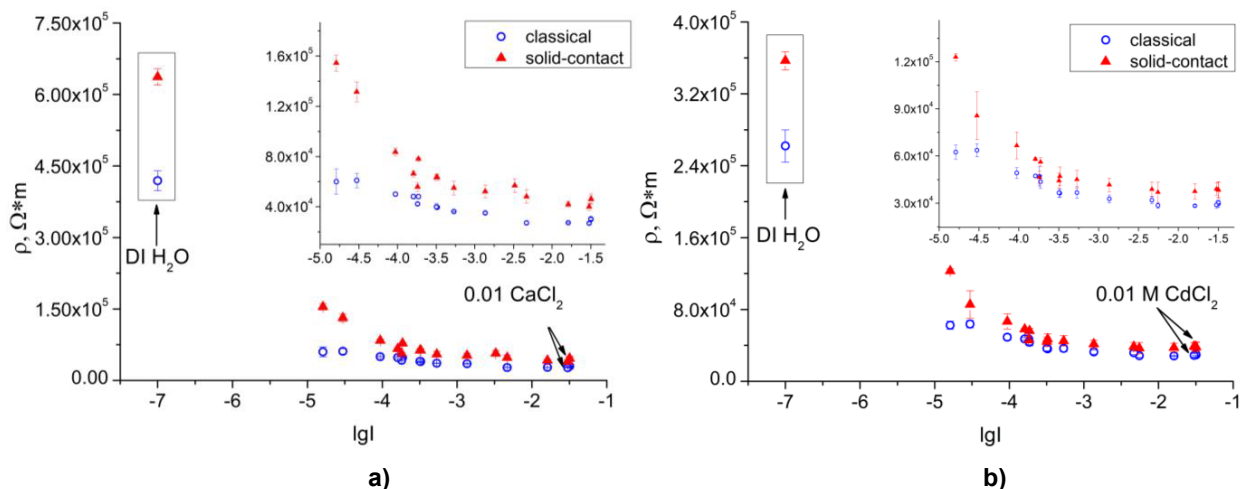
Student

[v\\_lukina@list.ru](mailto:v_lukina@list.ru)

Up to the present all theoretical considerations of the electrochemical properties of ion-selective membranes have been based on the assumption that the membrane is an organic phase which contacts with the aqueous solution phase. This concept predicts the constancy of the electrical resistance of the membrane within the range of the Nernstian potentiometric response of ion-selective electrodes (ISEs). However, a systematic study revealed that the bulk resistance of the membranes increases significantly along with the decrease of the electrolyte concentration, although the ISE potential obeys the Nernst law [1-5].

We have proposed a hypothesis about the cause of this contradiction, which for the first time explicitly links the electrochemical properties of sensory membranes with their heterogeneity due to the water sorption. Our investigation is devoted to a verification of this hypothesis.

We have shown for the first time that the resistance of ISE membrane is determined by the ionic strength of the solution (or the total concentration of electrolytes) and not by the concentration of ions to which the membrane is selective. The data on the resistivity of  $\text{Ca}^{2+}$ - and  $\text{Cd}^{2+}$ -selective membranes equilibrated with mixed solutions are presented in Figure 1.



**Figure 1.** The dependence of the resistivity of a)  $\text{Ca}^{2+}$ -ISEs membranes and b)  $\text{Cd}^{2+}$ -ISEs membranes on the ionic strength of mixed solutions.

The dependence of the membrane resistance on the ionic strength of the solution not only confirms the validity of our hypothesis, but for the first time offers the fundamental possibility of using the same sensor for determination of both activity and concentration of the ion of interest.

## References

- [1] Kondratyeva Y.O., Solovyeva E.V., Khripoun G.A., Mikhelson K.N. *Electrochim. Acta* **2018**, 259, 458-465
- [2] Ivanova A., Mikhelson K. *Sensors* **2018**, 18, 2062
- [3] Kondratyeva Y.O., Solovyeva E.V., Khripoun G.A., Mikhelson K.N. *Russ. J. Electrochem.* **2019**, 55, 1118–1126.
- [4] Kalinichev A.V., Solovyeva E.V., Ivanova A.R., Khripoun G.A., Mikhelson, K.N. *Electrochim. Acta* **2019**, 334, 135541.
- [5] Keresten V., Solovyeva E., Mikhelson K. *Membranes* **2021**, 11, 344.

Acknowledgements. This work was supported by the Russian Foundation for Basic Research (project No 19-03-00259).

# A NEW SIMPLE AND ENVIRONMENT-FRIENDLY SCHEME FOR THE FLUOROMETRIC DETERMINATION OF FORMALDEHYDE IN MILK

*Kochetkova M.A., Timofeeva I.I., Bulatov A.V.*

<sup>1</sup>Saint Petersburg State University, Saint Petersburg, Russia

Student

[st068389@student.spbu.ru](mailto:st068389@student.spbu.ru)

Formaldehyde is often added to milk to increase the shelf life, improve the appearance of the product and keep it odorless [1]. However, formaldehyde is a carcinogen and its daily consumption can be dangerous for human health.

Nowadays, there are various methods developed for the determination of formaldehyde in milk. However, many of them require to use highly toxic solvents and are characterized by tedious sample preparation. In this regard, a simple express and environmentally friendly scheme for the fluorometric determination of formaldehyde in milk with the use of thymol as "green" extraction solvent was developed.

The proposed scheme assumes the air-assisted liquid-liquid microextraction of the formaldehyde derivative into the molten thymol coupled with fluorometric analysis. The formation of derivative and extraction process are carried out by heating and stirring with air providing by thermostat and peristaltic pump, respectively. After extraction the organic phase with the derivative is placed on a paper template and fluorometric measurements are performed by spectrofluorometer equipped with the solid sample holder. The scheme proposed was applied for the determination of formaldehyde in three milk samples. The correctness of the results obtained was confirmed by the "add-found" method.

## References

[1] P. Singh., N. Gandhi *Food Rev. Int.* **2015**, 31(3), 236–261

Acknowledgements. This project was financially supported by the Russian Science Foundation (project no. № 21-13-00020, <https://rscf.ru/project/21-13-00020/>).

# METHANOL CONVERSION TO DIMETHYL ETHER OVER MODIFIED SILICA GEL ADSORBENTS

*Kostina A.S.<sup>1</sup>, Temerdashev Z.A.<sup>1</sup>, Kolychev I.A.<sup>2</sup>, Vasilev A.M.<sup>1</sup>, Dobroshtan A.V.<sup>1</sup>*

<sup>1</sup>Kuban State University, Krasnodar, Russia

<sup>2</sup>LLC «Gazprom transgaz Krasnodar», Krasnodar, Russia

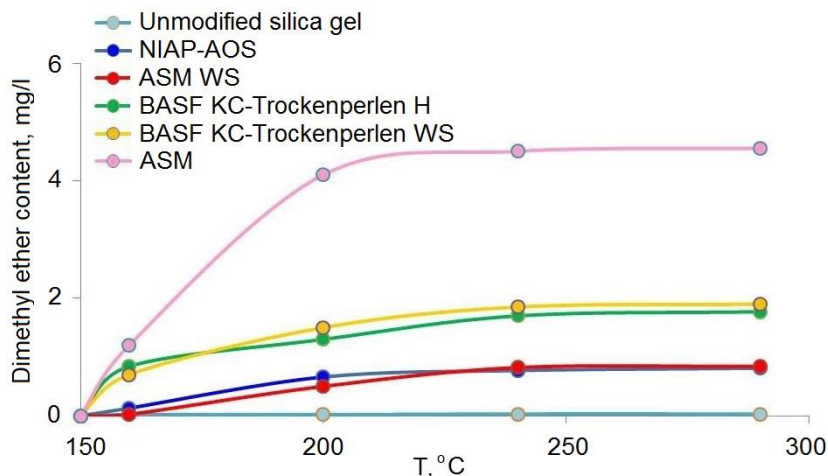
Postgraduate

[annakostina0@gmail.com](mailto:annakostina0@gmail.com)

In Russia, the prevention of hydrate formation is carried out by introducing methanol into gas distribution systems [1–2], and the Temperature Swing Adsorption method (TSA) is used to dry natural gas in adsorption columns. At the stage of high-temperature regeneration at 280–290°C at gas treatment units the utilization of methanol to dimethyl ether (DME) on silica gels becomes relevant [3].

In the present work the catalytic dehydration of methanol to DME has been studied over industrial adsorbents of the brands ASM, ASM WS, BASF KC-Trockenperlen H, BASF KC-Trockenperlen WS, NIAP-AOS, used in the purification of natural gas, and unmodified silica gel.

The catalytic evaluations were carried out in a fixed-bed reactor containing a standard mass of catalyst (2,0 g) at 120–290°C and flow rates from 200 to 2000 ml/min. The products were analyzed on-line every 10 min using a gas chromatography (Crystal-2000M) equipped with a flame ionized detector (GC-FID) connected to capillary column FFAP (50 m × 0,32 mm × 0,50 μm). The BET surface area and the total pore volume were measured using a N<sub>2</sub> adsorption-desorption isotherm method by Sorbtometer-M instrument. X-ray diffraction patterns were obtained to component identification (XRD-7000) using CuKα monochromatized source and Ni filters over the 2θ interval 3–80°.



**Figure 1.** Dependence of the yield of dimethyl ether on temperature (150–290°C) on adsorbents (flow rate 400 ml/min).

The results of the activity of adsorbents NIAP-AOS, ASM WS, BASF KC-Trockenperlen H and BASF KC-Trockenperlen WS, ASM (Figure 1) and X-ray diffraction patterns showed that the catalytic activity of silica gels is due to the interaction of methanol with the amorphous form of adsorbents. An increase in the surface area and the total pore volume also increases the catalytic activity of adsorbents in the methanol conversion to DME. Unmodified silica gel has practically no catalytic activity.

Thus, ASM catalyst with a surface area of 624 m<sup>2</sup>/g exhibits the highest methanol conversion. Decreasing methanol concentrations reduces atmospheric emissions and saves fuel gas consumed by a stationary thermal treatment unit.

## References

- [1] Yang M., Zhao J., Zheng J.-N., Song Y. *Appl. Energy* **2019**, 256, 113878
- [2] Pohanka M. *Biomed. Pap. Med. fac. Univ. Palacky Olomouc Czech. Repub.* **2016**, 160, 1, 54–63
- [3] Temerdashev Z.A., Rudenko A.V., Kolychev I.A., Kostina A.S. *Ecology and Industry of Russia* **2020**, 8, 17–221

Acknowledgements. The work was carried out within the framework of the State Assignment of the Ministry of Education and Science of Russia (project No FZEN-2020-0022).

# PROTOCOL DESIGN FOR DNA APTAMER SELECTION TO NIVALENOL – A DANGEROUS MYCOTOXIN IN FOOD AND FODDER INDUSTRY

*Kovalenko A.A.<sup>1</sup>, Kazartsev I.A.<sup>1</sup>, Sharoyko V.V.<sup>2</sup>*

<sup>1</sup> All-Russian Institute of Plant Protection (VIZR), Pushkin, Saint Petersburg, Russia

<sup>2</sup> Saint Petersburg State University, Saint Petersburg, Russia

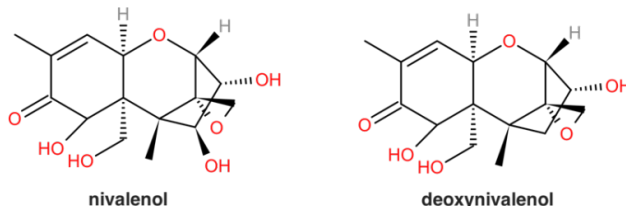
Research assistant

[ikovalenko239@gmail.com](mailto:ikovalenko239@gmail.com)

Aptamers (from Latin “aptus” – “to fit”) are single-stranded oligonucleotide molecules capable of binding to molecular targets with high affinity and specificity. Aptamers are considered to be oligonucleotide analogs of antibodies, although there are numerous advantages over antibodies in selection, fabrication and chemical properties. Affinity and specificity of aptamer binding have attracted interest to their widespread use in research, therapy and analytical practice, particularly to create highly sensitive and specific sensors [1]. Aptamer selection to a target of interest relies on SELEX method (Systematic Evolution of Ligands by EXponential Enrichment). During this process a starting library of randomized oligonucleotides is enriched with specific aptamers through repetitive rounds of fractionation and amplification of aptamers. There are numerous approaches to perform SELEX and many parameters can influence the course of the experiment [2].

Our work focuses on aptamers application for the creation of modern bioanalytical solutions for the analysis of mycotoxins, filamentous fungi secondary metabolites. The infection of food and forage crops by pathogenic fungi and contamination with mycotoxins, is consistently recorded in all regions of Russia and as well worldwide. This issue poses a serious threat on human and animal health [3]. The existing methods for the analysis of mycotoxins are mainly based on liquid chromatography and mass spectrometry. These methods are poorly suited for large-scale and rapid monitoring. Therefore, there is a need for development of novel analytical approaches. We believe that the aptamer technology has a great potential to revolutionize this field.

In order to select aptamers to yet unexplored mycotoxins we have developed a protocol for the selection of DNA aptamers to mycotoxins. The protocol was tested on nivalenol, a dangerous mycotoxin, which is without a specific aptamer. Selection experiment included negative selection with deoxynivalenol and its derivatives. The proposed selection procedure is aimed at obtaining aptamers capable of sensitive discrimination between these structurally similar and usually coexisting toxins (fig. 1).



**Figure 1.** Structures of trichothecene mycotoxins nivalenol and deoxynivalenol.

In course of the work, we have reviewed literature on SELEX approaches for small molecular targets and particularly mycotoxins. A practical comparison of approaches for the amplification of the aptamer library and the generation of ssDNA libraries was carried out. Parameters influencing these procedures and selection in general were investigated. Taking into account optimization results a protocol was developed for the selection of aptamers to nivalenol. Using this protocol 10 rounds of SELEX for nivalenol were performed. To identify potential aptamers many aptamer selection experiments rely on Sanger sequencing of molecular clones from enriched library or NGS data analysis of multimillion oligonucleotides libraries. In contrast we have studied the applicability of NGS data analysis for relatively small libraries (about 20 thousand sequences). Sequencing of libraries from rounds 1, 2, 3 and 10 was performed, several approaches for data analysis were evaluated and a panel of potential aptamers to nivalenol was identified. The developed procedure allows us to select aptamers to previously unexplored toxins for future application in biosensor design for real object analysis.

## References

- [1] Dunn M. R., Jimenez, R. M., Chaput J. C. *Nature Reviews Chemistry*. **2017**, *1*(10), 1-16
- [2] Komarova N., Kuznetsov A. *Molecules*. **2019**, *24*(19), 3598
- [3] Christiane Gruber-Dorninger T. Jenkins G.S. *Toxins*. **2019**, *11*(375), 1–25

Acknowledgements. This work was supported by the Russian Science Foundation (project No 19-76-30005)



# INTERACTION INVESTIGATION BETWEEN LIGHT HYDROCARBONS AND THE HOMOLOGOUS SERIES OF IONIC LIQUIDS AT HIGH PRESSURE STUDIED *IN SITU* BY ATR-FTIR SPECTROSCOPY

*Kovalev E.P.*<sup>1</sup>, *Shalygin A.S.*<sup>1</sup>, *Prikhod'ko S.A.*<sup>1</sup>, *Adonin N.Y.*<sup>1</sup>,  
*Martyanov O.N.*<sup>1</sup>, *Kazarian S.G.*<sup>1,2</sup>

<sup>1</sup>Borshkov Institute of Catalysis SB RAS, Novosibirsk, Russia.

<sup>2</sup>Department of Chemical Engineering, Imperial College London, London, United Kingdom

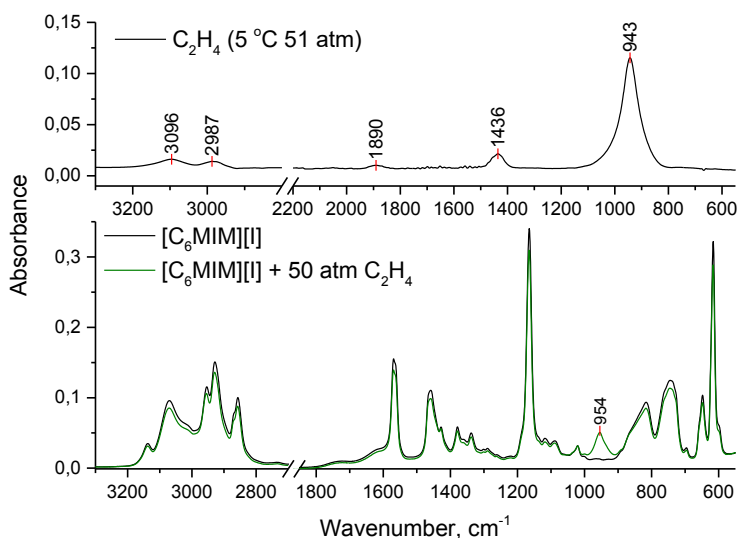
PhD student

[kovalev-e@catalysis.ru](mailto:kovalev-e@catalysis.ru)

The ionic liquids (ILs) are a special type of functional materials having enormous potential that makes the use of ILs promising for almost all fields [1]. Due to their unique physical and chemical properties, it is possible to create effective processes for the separation and the purification of gas mixtures by ionic liquids [2]. The practically limitless possibilities of IL modification allow one to control the “tuning” of ILs in order to enhance molecular interaction with target gas molecules, thus providing the better process performance.

Investigation of the interactions between sorbed gases and ILs permits optimizing the IL structure that is essential for creating a material with desired properties. Infrared spectroscopy has proven to be a reliable and convenient method for studying the mechanism of interactions and possible reactions between ionic liquids and gases *in situ* at high pressure [3,4]. To investigate the sorption processes of hydrocarbons (ethane, ethylene, acetylene), imidazolium based ILs ([C<sub>n</sub>MIM]<sup>+</sup>) with various anions ([BF<sub>4</sub><sup>-</sup>], [Hal<sup>-</sup>]) have been selected with varying the cation alkyl chain length (n = 2 - 10).

As a result of the application of the ATR-FTIR spectroscopy method, the spectra of liquid (high pressure) ethane and ethylene and the spectra of a series of ILs with sorbed hydrocarbons have been obtained for the first time under pressure and temperature variations. A detailed spectroscopic analysis of the IL ATR-FTIR spectra under the hydrocarbon pressure have been carried out, and regularities of spectral characteristics from the type of IL, hydrocarbon and other conditions have been revealed. For example, Fig. 1 shows the ATR-FTIR spectra of [C<sub>6</sub>mim][I] in the absence and under pressure of C<sub>2</sub>H<sub>4</sub>, as well as the spectrum of ethylene itself. During sorption, an absorption band of out-of-plane bending vibrations of CH<sub>2</sub> appears at 954 cm<sup>-1</sup>, with the shift of its position relative to pure ethylene indicating the interaction between the IL and the sorbed gas.



**Figure 1.** ATR-FTIR spectra of C<sub>2</sub>H<sub>4</sub> (7 °C и 51 atm) and [C<sub>6</sub>MIM][I] ionic liquid at 25 °C and ambient pressure and 50 atm of C<sub>2</sub>H<sub>4</sub>

## References

- [1] S.K. Singh, A.W. Savoy, *J. Mol. Liq.* **2020**, 297, 112038.
- [2] Y. Huang, Y. Zhang, H. Xing, *Chinese J. Chem. Eng.* **2019**, 27, 1374–1382.
- [3] S.G. Kazarian, B.J. Briscoe, T. Welton, *Chem. Commun.* **2000**, 2047–2048.
- [4] A.S. Shalygin, N.S. Nesterov, S.A. Prikhod'ko, N.Y. Adonin, O.N. Martyanov, S.G. Kazarian, *J. Mol. Liq.* **2020**, 315, 113694.

Acknowledgements. This work was supported by the Ministry of Education and Science of the Russian Federation within the Grant no. 075-15-2019-1876.

# APPLICATIONS OF MODIFIERS BASED ON IMIDAZOLIUM CATION TO ELECTROPHORETIC SEPARATION OF BIOLOGICALLY ACTIVE COMPOUNDS

*Kravchenko A.V.*<sup>1</sup>, *Kolobova E.A.*<sup>1,2</sup>, *Kartsova L.A.*<sup>1</sup>

<sup>1</sup>Saint Petersburg State University, Saint Petersburg, Russia

<sup>2</sup>The Federal State Institute of Public Health 'The Nikiforov Russian Center of Emergency and Radiation Medicine', Saint Petersburg, Russia, Russia

PhD Student

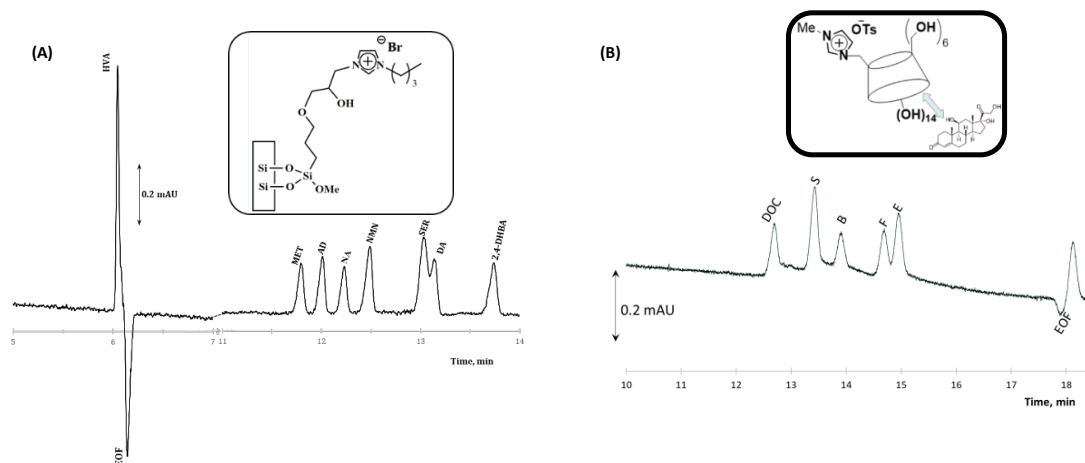
[kravchenko161216@gmail.com](mailto:kravchenko161216@gmail.com)

Capillary electrophoresis (CE) is an actively developing method that is fast and highly efficient, but it also has a number of limitations such as the sorption of analytes on the capillary walls, low detection limits, etc. The use of intracapillary preconcentration and the formation of dynamic or covalent coatings on the capillary walls allows to overcome these limitations.

In recent decades, imidazolium ionic liquids (IL) have been widely used in separation methods as modifiers due to their unique properties. The presence of an aromatic system in IL provides additional  $\pi$ - $\pi$  interactions with most biologically active analytes and improves their separation selectivity. At the same time, compounds based on imidazolium cations covalently bonded or adsorbed on capillary walls can reverse the electroosmotic flow and prevent analyte sorption.

In the present work, different approaches to electrophoretically separate biological active analytes with the usage of modifiers based on imidazolium cations will be considered. First of all, *N*-alkylimidazolium permanent coatings were covalently bonded to the capillary wall. This coating allows to determine biogenic amines in the capillary zone electrophoresis mode at negative polarity (Fig.1A). To realize the sweeping preconcentration mode and reduce the limits of detection (LOD), sodium dodecyl sulfate (SDS) was added into background electrolyte (BGE) (in concentration above the critical micelle concentration) and strongly interacted with hydrophobic alkyl groups in the covalent coating structure. The SDS forms negatively charged layer on the inner capillary surface. The double reversing EOF allows to carry out electrokinetic injection of the sample and *on-line* preconcentration by sweeping simultaneously. LOD were declined to 0.6-2.0 ng/mL and biogenic amines were determined in urine using the proposed method.

Another modifier based on the imidazolium cation  $\beta$ -cyclodextrin, was synthesized and used as a pseudo-stationary phase for corticosteroids separation. The presence of this modifier and 10 % acetonitrile in the BGE composition allows to baseline separate five steroids (cortisone (E), hydrocortisone (F), 11-deoxycortisol (S), corticosterone (B), 21-hydroxyprogesterone (DOC)) due to hydrophobic interactions between analytes and cyclodextrin cavity (Fig.1B). The positively charged associate of the modifier and corticosteroid could be electrokinetically injected that was the main idea of the new proposed method for steroid *on-line* preconcentration. This fact made it possible to reduce steroids LOD to 35-30 ng/mL and analyze them in human plasma after liquid-liquid extraction and concentration in 5 times by chloroform.



**Figure 1.** Possibilities of modifiers based on imidazolium cation in CE: Electropherogram of the mixture of neurotransmitters and their metabolites on *N*-alkylimidazolium covalent coating (A) and corticosteroids separation using pseudo stationary phase and 10 % ACN into BGE (B).

Acknowledgements. This work was supported by the Russian Science Foundation (project No 19-13-00370)

# APPLICATION OF MICROWAVE DIGESTION FOR ICP-MS ANALYSIS IN SILICA ROCK SAMPLES

*Kravchenko A.A.<sup>1,2</sup>, Nikolaeva I.V.<sup>1</sup>, Palessky S.V.<sup>1</sup>*

<sup>1</sup>Sobolev Institute of Geology and Mineralogy Siberian Branch of the Russian Academy of Sciences,  
Novosibirsk, Russia

<sup>2</sup>Novosibirsk State University, Novosibirsk, Russia

PhD Student

[a.kravchenko4@ngs.ru](mailto:a.kravchenko4@ngs.ru)

Microwave digestion allows to minimize the time of complete transformation of a solid sample to a liquid phase and to minimize the blank. While it provides both high temperature and pressure it is very efficient for solid samples, which are resistant to an open-vessel acidic digestion. In spite of the large number of publications on silica rock sample digestion there are different and sometimes contradicting conclusions on the efficiency of the microwave digestion technique. However, it is shown in several studies that only low silica rock samples can be dissolved successfully and quickly by using microwave digestion [1-3]. Low blanks provided by microwave digestion procedure are essential in analysis of ultramafic rock samples due to low element concentrations.

This work is devoted to the investigation of the microwave digestion efficiency for felsic, mafic and ultramafic rocks for determination of 32 elements (Sc, V, Cr, Co, Ni, Cu, Zn, Rb, Sr, Y, Zr, Nb, Cs, Ba, 14 REE, Hf, Ta, Th, U) by ICP-MS.

A series of experiments was carried out in order to optimize parameters of digestion (temperature, acid ratio, sample mass) in microwave system MARS-5. The HF/HNO<sub>3</sub> mixture in 4:1 ratio was used at the first stage of the final optimized procedure (60 minutes, 190°C, maximum pressure 20 atm), and after the SiF<sub>4</sub> evaporation the residue was treated with aqua regia (60 minutes, 190°C, maximum pressure 20 atm). Determinations were carried out using SF-mass-spectrometer ELEMENT (Finnigan Mat). Multielement standard solutions CMS-1, IV-ICPMS-71B, CMS-5 и IV-STOCK-10 (Inorganic Ventures) with a similar acidic composition to the analyzed solutions were used for external calibration and indium was used as the internal standard. The limits of detection were 0,0002-3 µg/g, allowing multielement determination in all investigated rock samples. The digestion technique was validated by the analysis of international geological reference materials BHVO-2 and BCR-2 (basalts), UB-N (serpentinite), JP-1 (peridotite). Relative standard deviations for determined elements were lower than 9% for reference materials BHVO-2 and BCR-2, lower than 12% for UB-N, and up to 10-35% for JP-1 due to low element concentrations near detection limits in this standard reference material. Insufficiency of the investigated parameters of microwave digestion for Russian reference materials SG-1A and SG-3 (granites) is shown. The advantages of the developed technique are low detection limits compared to fusion and reduced total analysis time compared to acid digestion without a microwave system.

The efficiency of microwave digestion for silica rock samples using UltraWAVE system allowing digestion at higher temperature and pressure (240°C, 70 bar) is also investigated. Comparison of digestion efficiency for silica rock samples using different types of microwave systems MARS-5 and UltraWAVE is carried out.

## References

- [1] *Geostand. Geoanalytical Res.* **2008**, 2, 167-180.
- [2] *Anal. Chim. Acta* **2012**, 713, 97-102.
- [3] *Geostand. Geoanalytical Res.* **2019**, 1, 189-208.

Acknowledgements. This work was supported by the state assignment IGM RAS №0330-2016-0013.

# STUDY OF IONIZATION OF VOLATILE ORGANIC COMPOUNDS IN PULSED GLOW DISCHARGE WITH TIME-OF-FLIGHT ION DETECTION

*Kravtsov D.V.<sup>1</sup>, Ganeev A.A.<sup>2</sup>, Gubal A.R.<sup>1</sup>, Chuchina V.A.<sup>1</sup>*

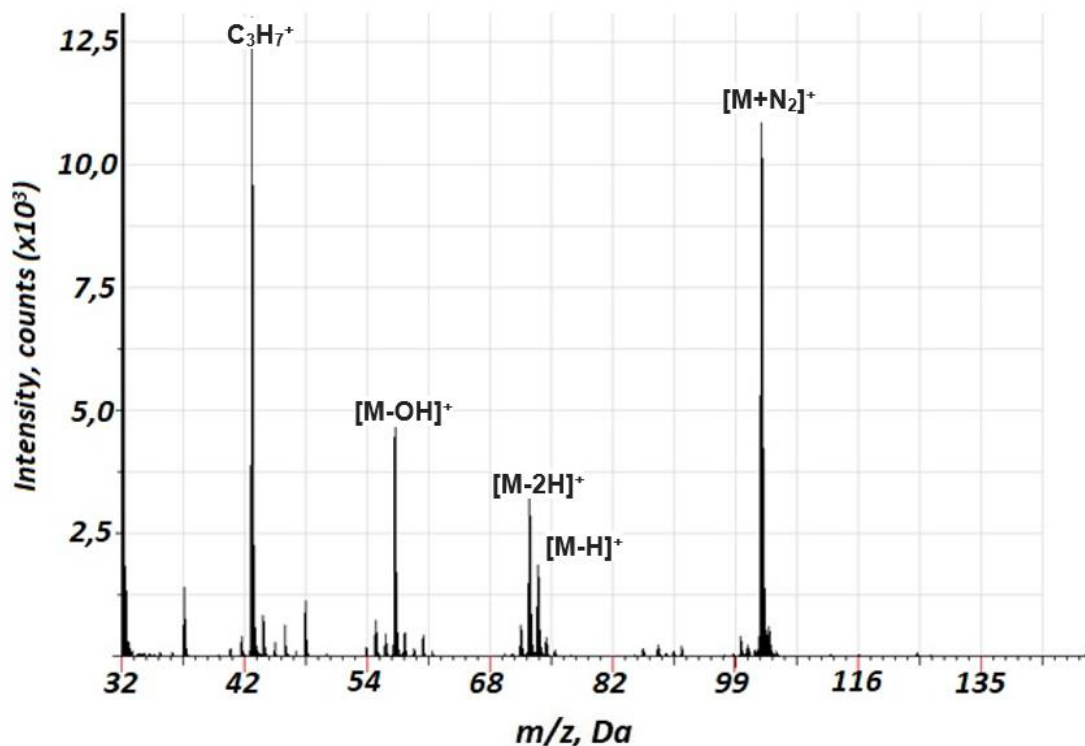
<sup>1</sup>Saint Petersburg State University, Saint Petersburg, Russia

<sup>2</sup>Institute of Toxicology of Federal Medico-Biological Agency, Saint Petersburg, Russia  
Student

[kravden97@yandex.ru](mailto:kravden97@yandex.ru)

Pulsed glow discharge is traditionally used for element and isotope analysis of solid materials. However, it was shown that it can be applied for determination of volatile organic compounds in air [1]. Ionization in microsecond pulsed glow discharge allows diminishing of fragmentation of a compound compared to electron ionization. Moreover, new mechanisms appear leading to a formation of associates, which opens a new possibility for determination and identification of VOCs [2].

In this study mass-spectra of a different volatile organic compounds, including alcohols, carboxylic acids and aromatic compounds were studied using Lumas-30 Time-Of-Flight mass-spectrometer with  $\mu$ s-pulsed glow discharge with copper hollow cathode. Approaches for direct determination of VOCs in air were developed and measurement parameters, such as pressure, repelling pulse delay, period and duration of discharge pulse, were optimized. It was found that ionization in glow discharge leads to a formation of  $MN_2^+$  associates with alcohols and  $MNO^+$  associates with carboxylic acids. The reduce of the fragmentation of compounds in comparison with electron ionization has also been shown.



**Figure 1.** Mass-spectra of butanol-1. M – sign for butanol-1 molecule.

Designed method could be applied for diagnosis of lung diseases by a direct determination of VOCs in human exhaled breath.

## References

- [1] J. Fandino, M. Bouza, J. Pisonero, D. Blanco, A. Sanz-Medel, N. Bordel. *Analytica Chimica Acta*, **2018**, 1038, 59-66
- [2] Anna Gubal, Victoria Chuchina, Natalya Ivanenko, Rong Qian, Nikolay Solovyev, Alexander Ganeev. *Spectrochimica Acta Part B*, **2020**, 173, 105986

# ELECTROCHEMICAL METHOD FOR DETECTING BACTERIA USING MACHINE LEARNING

*Lavrentev F.V.<sup>1</sup>, Rumyantsev I.S.<sup>1</sup>, Ivanov A.S.<sup>1</sup>, Nikolaev K.G.<sup>1</sup>, Skorb E.V.<sup>1</sup>*

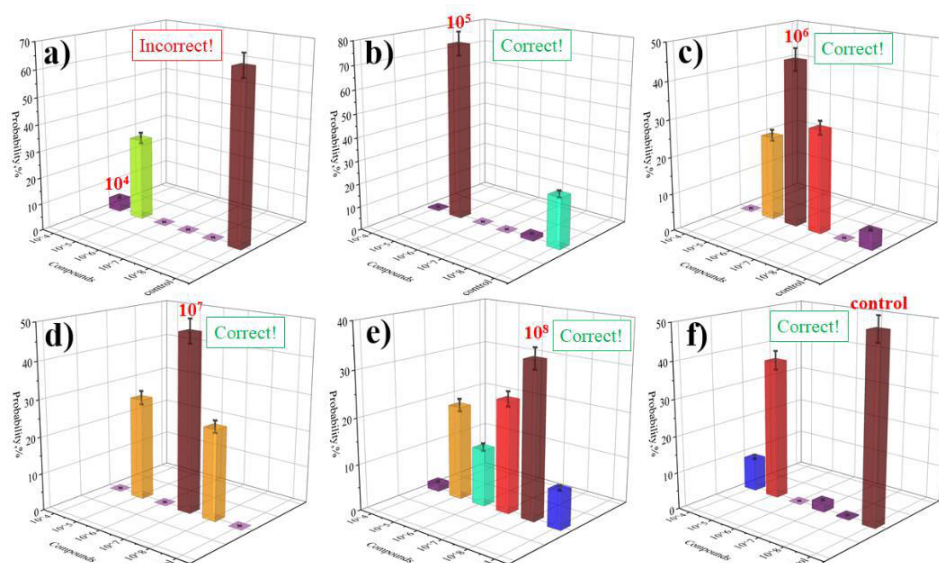
<sup>1</sup> ITMO University, St. Petersburg, Russia  
Student

[lavrentev@infochemistry.ru](mailto:lavrentev@infochemistry.ru)

The priority of any food manufacturer is to ensure the quality and safety of their products [1]. With the development of society and science, the demand for determining the viability of bacteria in the food and pharmaceutical industries, health care, environmental protection, biotechnology, etc. has risen sharply. Traditional methods are limited by time delays in analysis, costly and time-consuming sample preparation, and the need for highly skilled workers. Combination of analytical methods with machine learning methods provides high analytical accuracy in complex food matrices.

This research focuses on developing a simple approach to creating an electrochemical platform with high sensitivity and selectivity. We propose the principle of an electrochemical sensor platform consisting of a hydrogel interface and eutectic gallium-indium alloy electrodes for the semi-quantitative detection of bacteria in various systems [2]. When a potential difference is applied, a current flows through the system, as a result of which gallium is oxidized, and its cations begin to diffuse into the hydrogel. In the hydrogel, gallium cations interact with bacteria, their metabolites, and phosphate anions. As a result, we obtain I-V curves with different forms.

The collected volt-ampere data was used for machine learning. The multilayer perceptron model showed the best result, demonstrated 94% accuracy. Dividing the data into a training set (90%) and a test set (10%) allows you to check the accuracy of the model. This separation allows you to keep a sufficiently large number of values for training the model and does not greatly reduce the test suite. Multilayer Perceptron model was trained with the following parameters: learning rate - 0.1; impulse, - 0.1; the number of hidden layers, - 2; the number of nodes in the hidden layer, - 12. In five out of six cases, the multilayer perceptron model gave correct results in recognizing bacterial concentrations.



**Figure 1.** The results of the prediction of samples with different concentrations of bacteria, obtained on the model of a multilayer perceptron. (a) Graph for the sample with bacteria concentration  $10^4$ . (b) Graph for the sample with bacteria concentration  $10^5$ . (c) Graph for the sample with bacteria concentration  $10^6$ . (d) Graph for the sample with bacteria concentration  $10^7$ . (e) Graph for the sample with bacteria concentration  $10^8$ . (f) Graph for the sample without bacteria.

You can reduce this inaccuracy, increase the database, and adjust the tuning of the selected machine learning model. In addition, further adding statistically significant values to the database will reduce statistical error. This electrochemical system does a good job of detecting different concentrations of bacteria in gels by collecting large I-V data. Thus, the developed principle of the platform has a great prospect of being used as a more convenient method for the quantitative detection of bacteria.

## References

- [1] Trienekens J., Zuurbier P., *International Journal of Production Economics* **2008**, 113, 107–122
- [2] Ivanov A.S., Nikolaev K.G., Stekolshchikova A.A., etc. *ACS Appl. Bio Mater.* **2020**, 3, 7352–7356

## AZITHROMYCIN-SELECTIVE ELECTRODE

*Magomedov K.E.<sup>1</sup>, Tataeva S.D.<sup>1</sup>, Magomedova V.S.<sup>1</sup>, Zeynalov R.Z.<sup>1</sup>*

<sup>1</sup>Dagestan State University, Makhachkala, Russia

PhD

[m\\_kurban@mail.ru](mailto:m_kurban@mail.ru)

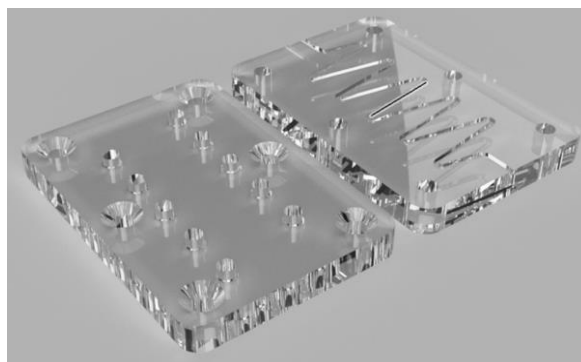
Currently, antibiotics occupy a leading place in medicine and veterinary medicine in the treatment of various infectious and inflammatory diseases and for anti-infective prophylaxis in surgery. The widespread use of antibiotics has led to the selection and spread of resistant strains of the main pathogens. Researchers and clinicians are trying to solve this problem in ways: by synthesizing antibiotics of new generations, creating inhibitors of  $\beta$ -lactamases, combining already known antibiotics, creating new dosage forms and changing the dosage regimen, which, in turn, requires the determination of antibiotics in various objects.

In addition to medical purposes, antibiotics are widely used to improve the quality and safety of feed, in the production of products from meat, milk, vegetables, etc. Sources of antibiotics in the future are wastewater from pharmaceutical enterprises and clinics.

Consequently, the definition of antibiotics as one of the groups of medicinal compounds that have become widespread, but at the same time have a potential hazard to human health, is an urgent problem in modern clinical, analytical chemistry, veterinary medicine, pharmaceutical and food industries. Azithromycin is an antibiotic medication used for the treatment of a number of bacterial infections [4]. This includes middle ear infections, strep throat, pneumonia, traveler's diarrhea, and certain other intestinal infections [4]. Along with other medications, it may also be used for malaria. It can be taken by mouth or intravenously with doses once per day [1].

Common side effects include nausea, vomiting, diarrhea and upset stomach. An allergic reaction, such as anaphylaxis, QT prolongation, or a type of diarrhea caused by *Clostridium difficile* is possible. No harm has been found with its use during pregnancy. Its safety during breastfeeding is not confirmed, but it is likely safe. Azithromycin is an azalide, a type of macrolide antibiotic. It works by decreasing the production of protein, thereby stopping bacterial growth [1].

In this work, a plasticized polyvinyl chloride membrane with an electrode active component selective to kanamycin is used as an ion-selective membrane. The ISE body is acrylic glass with a specific geometry of the channels. On the basis of the body and membranes, a flow cell is made suitable for the analysis of small samples.



### References

[1] Azithromycin. The American Society of Health-System Pharmacists. Archived from the original on 5 September 2015. Retrieved 1 August 2015.

Acknowledgements. The work was carried out with the financial support of the state order FZNZ-2020-0002

DETERMINATION OF MONATOMIC ALCOHOLS, TURPENTINE AND PINE FLOTATION OIL  
ON GS-5MS AND SH-STABILWAX-DB CAPILLARY COLUMNS

*Malyshev A.N., Menshikov S.Yu.*

Ural State Mining University, Yekaterinburg, Russia

Student

[malyshev.k1b@gmail.com](mailto:malyshev.k1b@gmail.com)

Capillary columns GsBP-5MS and SH-Stabilwax-DB have been used for the study of monatomic alcohols, non-freezing liquids in accordance with the technical specifications 20.59-001-39528361-2019. GsBP-5MS has been also used to study turpentine and pine flotation oil. The retention times of alcohols have been determined for methanol, ethanol, isopropyl alcohol, butyl alcohol, isoamyl alcohol,  $\alpha$ -pinene,  $\alpha$ -terpineol. In the initial product, the amount of  $\alpha$ -pinene and  $\alpha$ -terpineol has been calculated by the normalization method. An assumption was made for the method of obtaining the raw material based on the data of chromatographic analysis.

Chromatography conditions to study monatomic alcohols and non-freezing liquids used as following: gas chromatograph Shimadzu GC-2030 with FID, carrier gas-N<sub>2</sub>, SH-Stabilwax-DB (30 m, 0.53 mm, 1.0  $\mu$ m) / GsBP-5MS (30 m, 0,25 mm, 0,25  $\mu$ m); temperature in the injector and detector - 200 °C; analysis was performed in the thermostat temperature programming mode – initial temperature - 40 °C, after 10 minutes the temperature increased to 125 °C at a rate of 6 °C per minute, the final temperature was held for 10 minutes until the end of the analysis.

Chromatography conditions to study pine flotation oil and turpentine were: gas chromatograph Shimadzu GC-2030 with FID, carrier gas-N<sub>2</sub>, GsBP-5MS (30 m, 0.25 mm, 0.25  $\mu$ m); the temperature in the injector is 260 °C and the detector is 270 °C; the analysis was carried out in the thermostat temperature programming mode – the initial temperature is 40 °C with an increase in temperature to 260 °C at a rate of 10 °C per minute, the final temperature was held for 10 minutes until the end of the analysis.

On the SH-Stabilwax-DB column, the retention time of isopropyl alcohol was less than the retention time of ethyl alcohol (6.6 and 7 minutes), even though the molar mass and boiling point of isopropanol is higher than that of ethanol. At the same time, on the GsBP-5MS column, isopropanol comes out later than ethanol, which corresponds to the boiling points of monatomic alcohols. The retention time of isopropyl alcohol on the GsBP-5MS column overlaps with the retention time of ethyl alcohol (2.7 and 2.5 minutes) [1].

Pine flotation oil is a fraction of terpene alcohols obtained by the method of additional rectification of turpentine. The content of  $\alpha$ -pinene as a result of this process decreases in parallel with the increase in the amount of  $\alpha$ -terpineol due to the destruction of the small cycle of  $\alpha$ -pinene. The quality of pine flotation oil is determined by the concentration of  $\alpha$ -terpineol, which in turn affects the properties of the product as a foaming agent.

On the GsBP-5MS column, the retention time of  $\alpha$ -pinene was 7 minutes for both turpentine and pine flotation oil. The content of the main substance  $\alpha$ -pinene in turpentine was found to be 49.5 %. In pine flotation oil, the main substance was detected as  $\alpha$ -terpineol-30.2 % (calculated by the normalization method) with a retention time of 13.3 minutes [2].

In [3], the content of  $\alpha$ -terpineol was 53.13 % in the process of obtaining from  $\alpha$ -pinene, but the conditions for chromatographic analysis were not given. Based on this work, pine oil can be obtained both ways from turpentine with subsequent distillation of the hydration product, and from  $\alpha$ -pinene. In the second case, the distillation of the hydration product may not be required.

Apparently, the pine flotation oil sample was obtained by hydration of turpentine due to the low content of  $\alpha$ -terpineol rather than from  $\alpha$ -pinene.

It is planned to study the products of oxidation and hydration of turpentine by using gas and liquid chromatography methods.

#### References

- [1] Malyshev A.N., Menshikov S.Yu. *Problems of theoretical and experimental chemistry-XXXI* **2021**, 273
- [2] Malyshev A.N., Menshikov S.Yu. *Scientific bases and practice of processing of ores and technogenic raw materials – XXVI* **2021**, 149-151
- [3] Shpak S.I., Chernysheva T.V., Fleisher V.L., Kvesco A.A. *Proceedings of BSTU* **2016**, 4 (186), 144-148

Acknowledgements. The research was funded by the Ministry of Science and Higher Education in accordance with the state assignment for Ural State Mining University no. 075-03-2021-303 from 29 December 2020.

# SPECTROPHOTOMETRIC METHOD FOR DETERMINATION OF UREA IN MILK BASED ON MICROEXTRACTION IN DEEP EUTECTIC SOLVENT

*Markova U.O.<sup>1</sup>, Shishov A.Y.<sup>1</sup>*

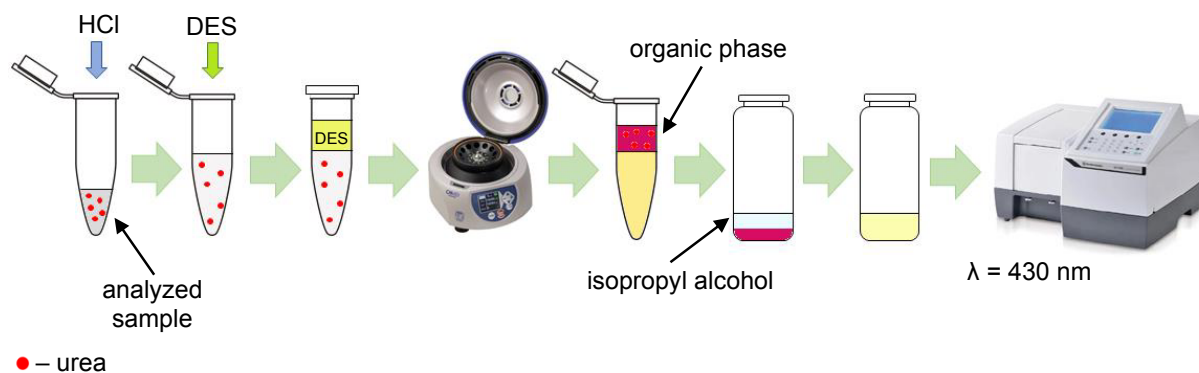
<sup>1</sup>Department of Analytical Chemistry, Institute of Chemistry, Saint Petersburg State University, Saint Petersburg, Russia  
Student

[ulya.markova.01@mail.ru](mailto:ulya.markova.01@mail.ru)

Food quality control is an important step in preventing a problem currently existing in the food industry which is associated with food adulteration. Milk is an important constituent of the human diet that is rich in proteins, carbohydrates, minerals and vitamins, all of which are essential to human health. Due to its high nutritional value, global production and consumption of milk have increased. As a result, milk is the most likely food item being at risk of adulteration. Milk adulteration typically involves dilution and/or addition of inexpensive, low-quality, and sometimes dangerous products in order to increase the volume, mask inferior quality, or replace the natural substances in milk for economic gain. Urea being a nitrogenous compound is added in milk to increase the apparent protein content. The concentration of urea beyond the upper limit (700 mg/L) can cause various diseases such as indigestion, ulcers, and renal insufficiency. Therefore, rapid urea detection has great significance for the quality control of milk products.

Many established methods for urea determination in milk require the tedious sample pretreatments due to the complex matrix of milk and the use of a large amount of organic solvents such as methanol, acetonitrile and chloroform and etc. for extraction, separation, and preconcentration. These conventional organic solvents are of low cost and are easy to evaporate. However, their residue levels and resulting pollution are of concern. Deep eutectic solvents (DES) have recently become increasingly popular as ecological effective extractants. A DES is generally composed of two or three cheap and safe components which are capable of associating with each other, through hydrogen bond interactions, to form an eutectic mixture. The resulting DES is characterized by a melting point lower than that of each individual component.

In the current study, an efficient and rapid method for the quantification of urea in milk is presented. This method involves a spectrophotometric determination of urea in milk samples and is based on a colorimetric reaction between urea and 4-dimethylbenzaldehyde. A novel deep eutectic solvent obtained by thymol and 4-dimethylbenzaldehyde (1:1, mol/mol) was used as an effective extractant for urea determination in milk. The procedure included mixing of analyzed aqua sample of milk, hydrochloric acid and deep eutectic solvent. After extraction and phase separation, the organic phase was taken and mixed with isopropyl alcohol and analyzed on a spectrophotometer at a wavelength of 430 nm. In this work, the conditions for urea extraction were optimized (hydrochloric acid concentration, temperature, extraction time). Under optimal conditions, the limit of detection for urea in milk were 10 mg kg<sup>-1</sup>. Low limit of detection and the use of deep eutectic solvent instead of organic solvents make it possible to use this method for food quality control.



**Figure 1.** Scheme of spectrophotometric method for determination of urea in milk based on microextraction in deep eutectic solvent.

**Acknowledgements.** The work was supported by a grant from the President of the Russian Federation MK-1154.2020.3. Scientific research was partially performed at Chemical Analysis and Materials Research Centre of Saint Petersburg State University.



*Melesova M.A., Shishov A.Y.*

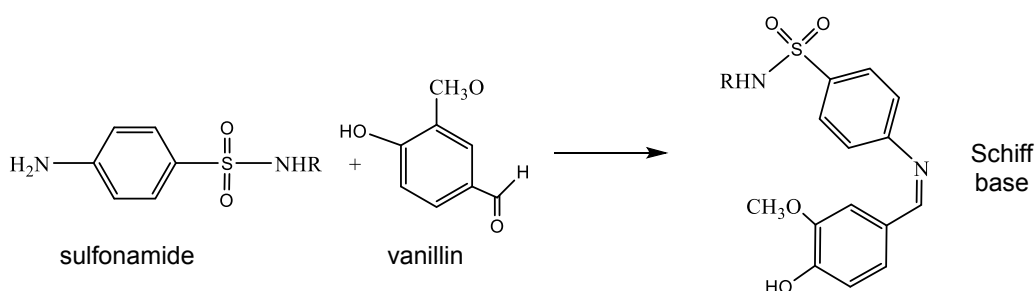
Saint Petersburg State University, Saint Petersburg, Russia

Student

[mariamelesova@gmail.com](mailto:mariamelesova@gmail.com)

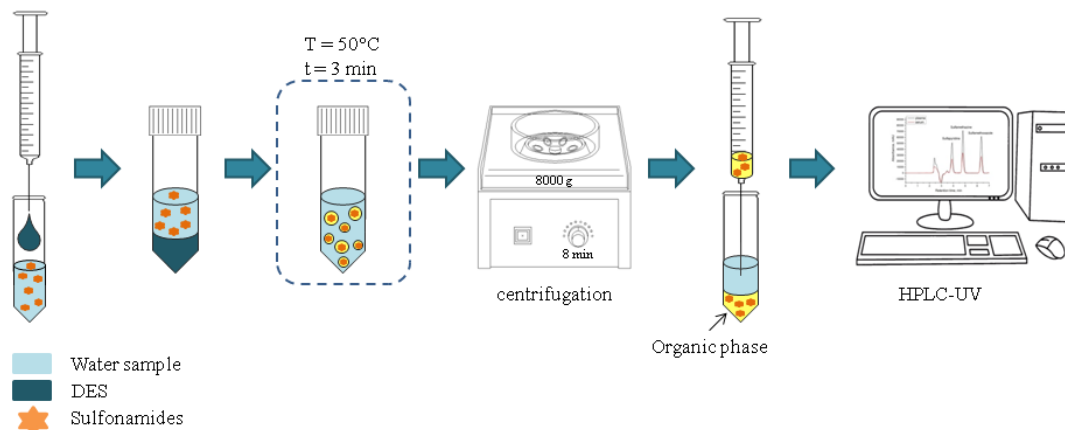
Sulfonamides (SAs) are the first class of synthetic antibiotics. SAs are widely used in medicine and veterinary to treat diseases of gastrointestinal tract and genitourinary system. SAs' metabolites are often found in food samples, which may be caused by misuse of SAs for treatment. It can damage human health: can cause allergies or development of antibiotic resistance.

The main problem of food analysis is low concentration. So sample pretreatment procedure needs a concentration stage. Recently, deep eutectic solvents (DES) have been increasingly used as effective eco-friendly extractants. DESs are mixtures of two or more precursors with a melting temperature lower than that of the individual components of DESs. In this paper, new DES based on vanillin and thymol was investigated for extraction and preconcentration of sulfonamides from food samples. It is known that sulfonamides react with vanillin to form colored Schiff bases (figure 1). So vanillin is precursor of DES and component for the derivatization reaction simultaneously.



**Figure 1.** Schiff base reaction between sulfonamide and vanillin.

An effective, fast and sensitive liquid-liquid microextraction method based on the use of hydrophobic deep eutectic solvent was developed to preconcentrate and extract sulfonamides in food samples. DES based on thymol and vanillin (1:1 mol/mol) was considered as effective solvent. Component of deep eutectic solvent (vanillin) played key role for derivatization and for separation of target analytes. The approach (figure 2) was applied for the HPLC-UV determination of sulfapyridine, sulfathiazole, sulfacetamide and sulfadiazine in food samples. Some parameters of extraction (pH of sample solution, extraction temperature and extraction time) were investigated and optimized. Under the optimum conditions, good linearity in the range of 0.5-50 mg L<sup>-1</sup> was obtained. The limit of detection was 0.05 mg L<sup>-1</sup>.



**Figure 2.** Schematic representation of the pretreatment procedure.

Acknowledgements. This work was supported by the Russian Science Foundation (project No 20-73-00043)

## QUANTITATIVE ASSESSMENT OF THE ACIDITY IN TONIC AND SOFT DRINKS

Misurkina E.K., Semenchuk O.I., Bazankova E.A.,  
Zachernyuk B.A., Solovyova E.N., Roeva N.N.

Saint Petersburg State University, Saint Petersburg, Russia  
Moscow State University of Food Production, Moscow, Russia  
Student  
[misurochka01@mail.ru](mailto:misurochka01@mail.ru)

The composition of soft and tonic drinks as acidity regulators includes weak acids. They form buffer systems together with the salts. It provides a stable level of active acidity and takes part in the formation of taste and aroma [1].

The purpose of this work was to determine the acidity content in soft drinks and tonic drinks by chemical and physico-chemical analysis methods [2].

Coca-Cola and Sprite were chosen as objects of research because they are popular among groups of different age categories.

To determine the acidity of the Sprite was used the acid-base titration method. The titrated acidity in the sample of the Sprite (g/L) was calculated by the formula:  $T = a \cdot K \cdot 0.0064 \cdot 100$ , where  $a$  - the volume of NaOH spent on titration of the aliquot of the sample, g/mL;  $K$  - correction coefficient for NaOH normality,  $K = 1$ . It was calculated that 1 ml of 0.1 N NaOH spent on titration of the sample corresponds to 0.0064 g of citric acid. According to the results of acid-base titration in the Sprite, the titratable acidity was 2.62-2.88 g/L, which did not exceed the norm [3].

To determine the acidity in Coca-Cola was used the method of direct potentiometry (Coca-Cola is a colored drink and the use of acid-base titration with an indicator is not suitable).

$$C_a = 3.3 \times 10^{-9} \text{ mol/L}$$

The mass concentration of the acid was calculated by the formula:

$$X = C_a \cdot M_a = 3.3 \times 10^{-9} \times 98 = 3.32 \times 10^{-7} \text{ g/L}$$

According to the data, the maximum permissible rate of orthophosphoric acid in tonic drinks is 0.7 g/L. Thus, the acid content in Coca-Cola according to the results of direct potentiometry and calculations did not exceed the norm.

### References

- [1] David P. Steen and Philip R. Ashurst. *Carbonated Soft Drinks Formulation and Manufacture*. **2008**, 416
- [2] *Youth and science: step to success: collection of scientific papers of the 5th all-Russian scientific conference of young scientists*. **2021**
- [3] Ermolaeva G.A., Kolcheva R.A. *Technology and equipment production of beer and soft drinks*. **2000**, 416

# ELECTROPHORETIC ANALYSIS OF AMINO ACIDS IN CULTURE BROTH USING (2-HYDROXYPROPYL)- $\beta$ -CYCLODEXTRIN AS A MODIFIER/CHIRAL SELECTOR

*Moskvichev D.O., Makeeva D.V., Kartsova A.A.*

Saint Petersburg State University, Saint Petersburg, Russia

Student

[moskv.danil@gmail.com](mailto:moskv.danil@gmail.com)

Amino acids (AA) are the most important diagnostic markers, the content of which is controlled in various biological fluids (blood, urine, amniotic fluid, etc.). Capillary electrophoresis (CE) possesses rapidity, high efficiency, simplicity of sample preparation, and instrumentation, therefore, it is used to determine these analytes. However, electrophoretic analysis of samples with complex matrices faces problems: insufficient selectivity and detection limits, interfering components from the matrix. To overcome the first limitation, both chiral and achiral modifiers are introduced into background electrolyte (BGE). Meanwhile, to solve the second problem, an adequate choice of sample preparation and operational concentration of the compounds to be determined is required. In this case, amino acids were determined in the form of complexes with copper (II) ions, which makes it possible to detect analytes that do not absorb in the UV range, regardless of the rest of the sample components [1]. The introduction of (2-hydroxypropyl)- $\beta$ -cyclodextrin (2-HP- $\beta$ -CD) into this system leads to an increase in selectivity and makes it possible to determine aromatic amino acids. We applied the methodology from [1] to study amino acid metabolism in non-alcoholic fatty liver disease (NAFLD) using the cellular model of the disease in vitro obtained by exposing HepG2 hepatocyte cells to palmitic and oleic acids (0.75 mM, 1: 2) conjugated with bovine serum albumin (1.5%) (conducted jointly with the State Research Institute of Highly Pure Biopreparations, St. Petersburg). Fatty acids were added to the cell culture broth (DMEM, Biolot) - the steatosis group, the control groups of cells grew in the DMEM medium. The change in the amino acid composition over time was revealed. There were marked differences in the concentration profiles for arginine, alanine, valine, leucine, glutamine, and glutamic acid in cells of the steatosis and control groups. This allows us to draw conclusions about the nature of metabolic disorders in diseased cells in comparison with healthy ones. However, the point remained unclear: the introduction of 2-HP- $\beta$ -CD did not lead to chiral separation. We assumed that under the conditions of analysis (20 mM sodium acetate; 50 mM Cu<sup>2+</sup>, pH 4.3, 10 mM 2-HP- $\beta$ -CD), complexes of amino acids with copper ions are included in the cavity of the macrocycle, rather than individual molecules of analytes. It is known that the enantioselectivity in chiral separation depends not only on the specific chiral selector and its concentration, but also on the pH of the supporting electrolyte. For this, experiments were planned on the electrophoretic separation of AA in the presence of copper (II) ions at pH>11 (5 mM phosphate buffered solution pH 12; 1 mM Cu<sup>2+</sup>, 2 mM 2-HP- $\beta$ -CD). Under these conditions, tryptophan enantiomers were separated. Herewith analysis time, efficiency and enantioselectivity for other amino acids required a different solution. The ability for chiral recognition with the participation of cyclodextrins is improved in the case of analyte derivatives. It seemed extremely attractive to test in one analytical cycle a variant of intracapillary derivatization with the introduction of chromophore groups into amino acid molecules, providing their spectrophotometric detection, chiral separation and concentration. The reaction with phthalaldehyde and N-acetyl-L-cysteine was chosen; one of its advantages is high conversion rate. We have performed a successful separation of the 6 amino acid enantiomers with this approach. The effect of the concentration of 2-HP- $\beta$ -CD (0.1-0.7 mM) in the BGE on the selectivity of amino acid derivatives was studied.

## References

[1] *J. Chromatogr. B.* **2020**, 1156, 122304

Acknowledgements. This work was supported by the Russian Science Foundation (project No 19-13-00370). The authors are grateful to the research team of the State Research Institute of Highly Pure Biopreparations for the biological part of the work.

# MICROEXTRACTION OF MELAMIN FROM DAIRY PRODUCTS IN DEEP EUTECTIC SOLVENT PRIOR TO HPLC-UV ANALYSIS

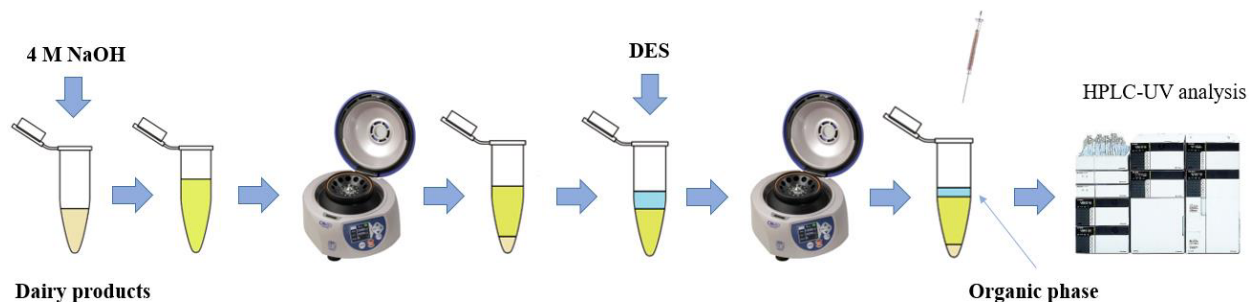
*Nizov E.R.<sup>1</sup>, Shishov A.Y.<sup>1</sup>*

<sup>1</sup> Department of Analytical Chemistry, Institute of Chemistry, Saint Petersburg State University, Saint Petersburg, Russia  
Student  
[st076763@student.spbu.ru](mailto:st076763@student.spbu.ru)

Melamine ( $C_3H_6N_6$ ) is a heterocyclic nitrogen compound which is used in the synthesis of melamine-formaldehyde resins. But because of its high percentage of nitrogen and low price melamine was illegally added to dairy products, infant formulas, chocolates, etc in order to increase the protein content. Melamine itself has a low toxicity, but in the presence of cyanuric acid, melamine precipitates in the kidneys in the form of melamine cyanurate crystals, which can lead to kidney failure.

The need of monitoring melamine required the development of analytical methods with higher sensitivity and rapidness. Due to the complex matrix of the dairy products, the preparatory stages are necessary for its subsequent analysis. Deep eutectic solvents have recently become increasingly popular as an ecological effective extractants. These eutectic solvents are compounds formed by a donor and an acceptor of hydrogen bond, the formation of this bond significantly lowers the melting point of the eutectic solvent. Deep eutectic solvents can be made from environmentally friendly natural compounds such as thymol, menthol and fatty acids.

In current work, natural deep eutectic solvents were firstly used for separation and concentrate of melamine from milk and dairy products for subsequent HPLC-UV analysis. DESs based on natural terpenes (thymol and menthol) and fatty acids were considered as eutectic solvents. In current work was shown that DES that consist of thymol and carboxylic acids show the highest extraction efficiency at the level of 95% in a wide pH range. It was also optimized the conditions for the melamine extraction, such as the ratio of the extractant and the sample, the extraction time, and the effect of the acidity. Optimal conditions allow to use this method to determine the melamine at the level of  $1 \mu\text{g}/\text{kg}$ , which allows to use this method for food quality control. At the same time, the use of natural eutectic solvents made it possible to completely remove the need of organic solvents at the sample preparation stage.



**Figure 1.** Scheme of microextraction of melamine from a powdered milk using DES prior to HPLC-UV analysis.

**Acknowledgements.** The study was supported by a grant from the President of the Russian Federation MK-1154.2020.3. Scientific research was partially performed at Chemical Analysis and Materials Research Centre of Saint Petersburg State University.

# BIOELECTROCATALYSIS BY PQQ-GLUCOSE DEHYDROGENASE ENHANCED BY ELECTROPOLYMERIZED AZINES FOR ADVANCED BIOSENSORS

Orlov A.K.<sup>1</sup>, Galushin A.A.<sup>2</sup>, Karyakin A.A.<sup>2</sup>, Komkova M.A.<sup>2</sup>

<sup>1</sup>Moscow State University, Faculty of Material Sciences, Moscow, Russia

<sup>2</sup>Moscow State University, Chemistry Department, Moscow, Russia

Student

[Aleksei.Orlov@student.msu.ru](mailto:Aleksei.Orlov@student.msu.ru)

Being true dielectrics, the enzymes must be properly oriented on the electrode surfaces to maintain direct bioelectrocatalysis [1]. To improve efficiency of bioelectrocatalysis we proposed to use conductive polymers, containing analogues of PQQ-Glucose Dehydrogenase (PQQ-GDH) substrates as substituents. On the one hand, displaying affinity to the active site, these polymers are expected to anchor the enzyme and facilitate electron transfer. On the other hand, rather low redox potentials of polyazines would allow to avoid interfering of reductants. Moreover, compared to biosensors based on freely diffusing azine dyes with inherently low operation stability [2], the use of polymer would provide advanced operational stability of the corresponding biosensors.

In order to check orientation effect of the polyazines on the PQQ-GDH we electropolymerized Methylene Green, Methylene Blue, Toluidine Blue, Azure A and Coomassie Brilliant Blue in cyclic voltammetry mode [3]. PQQ-GDH was immobilized on the polyazines modified electrodes by adsorption.

In the present study, characteristics of the developed biosensors were investigated in in chronoamperometric regime. Chronoamperometric response remain more than 75% of the initial response after 250 injections of 0.1 mM glucose solutions. Thus, allowing long-term monitoring without sensitivity loss.

The steady-state current-potential curves of bioelectrocatalytic glucose oxidation for PQQ-GDH were investigated. The half-wave potential of curve for Methylene Blue is  $80 \pm 10$  mV. This value is close to the half-wave potential of that for PQQ-GDH adsorbed on blank electrode. Though redox potentials of the electropolymerized Methylene Green are higher, in addition to a similar anodic wave of  $120 \pm 20$  mV, the cathodic one with the half-wave potential of  $-80 \pm 7$  mV appears. A difference between anodic and cathodic waves reflects a thermodynamic stability of the intermediate state of PQQ, a semiquinone radical, as it is related to semiquinone formation constant. This value implies that poly(Methylene Green) stabilizes PQQ semiquinone radical. The use of polymer of azine dyes increases the operational stability. The half-wave potentials for poly(Methylene Green) are in a good agreement with those registered for PQQ-glucose dehydrogenase covalently bound to carbon nanotubes.

Efficient of direct bioelectroOn an unmodified graphite electrode the catalytic currents were  $0.2 \mu\text{A}\cdot\text{cm}^{-2}$ , that is more than 70 times lower than on biosensor based on poly(Methylene blue). At the same time for poly(Methylene green) electrocatalytic currents were  $170 \mu\text{A}\cdot\text{cm}^{-2}$  already at 0.0 V vs. Ag/AgCl, that is more than 10 times higher than for poly(methylene blue) and 700 times higher than on unmodified biosensor. In the presence of both glucose and the freely diffusing mediator phenazine metasulfate the observed current values over an entire potential range are rather similar indicating similar amount of active PQQ-glucose dehydrogenase on all types of electrodes. Accordingly, these studies allow us to conclude that poly(Methylene green) exhibits an orienting effect in relation to the enzyme protein. Wherein, the maximal current for the biosensor based on poly(methylene green) – up to  $220 \mu\text{A}\cdot\text{cm}^{-2}$  - is only 5 times lower, than that in the presence of diffusing mediator phenazine methosulphate.

SPE|polyMG|PQQ-GDH electrode has been tested for sweat analysis. Pearson correlation coefficient is of 0.88 pointing to good agreement with reference method. A successful validation of the biosensor confirms a possibility of using this sensors for non-invasive diagnostics.

## References

- [1] Gladisch, J., Sarauli, D., Schäfer, D., Dietzel, B., Schulz, B., & Lisdat, F., Towards a novel bioelectrocatalytic platform based on “wiring” of pyrroloquinoline quinone-dependent glucose dehydrogenase with an electrospun conductive polymeric fiber architecture. *Scientific Reports*, **2016**, 6(1).
- [2] Sekretaryova Alina N., Vokhmyanina Darya V., Chulanova Tatyana O., Karyakina Elena E., Karyakin Arkady A., Reagentless Biosensor Based on Glucose Oxidase Wired by the Mediator Freely Diffusing in Enzyme Containing Membrane, **2012**. 84(3): p. 1220-1223.
- [3] A.A. Karyakin, E.E. Karyakina, and H.L. Schmidt, Electropolymerized azines: A new group of electroactive polymers. *Electroanalysis*, **1999**. 11(3): p. 149-155.

Acknowledgements. This work was supported by Russian Foundation for Basic Research, project # 20-33-70107

# DETERMINATION OF OXYGEN IN CHLORALUMINATES BY THE REDUCTIVE MELTING METHOD

*Palaeva T.V.*

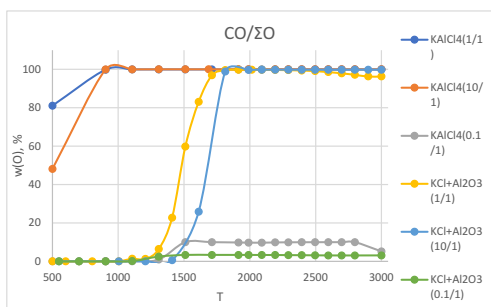
<sup>1</sup>Saint Petersburg State University, Saint Petersburg, Russia

Student

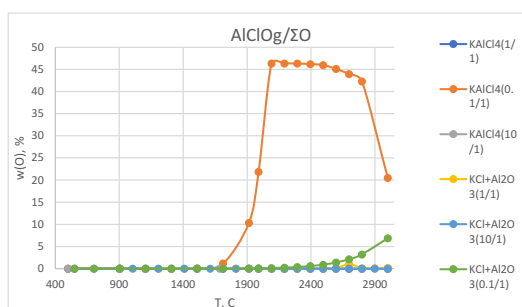
[Palaeva.tanya00@mail.ru](mailto:Palaeva.tanya00@mail.ru)

Potassium chloraluminum melt ( $\text{AlCl}_3 - \text{KCl}$ ) is used to separate zirconium and hafnium chlorides. Oxygen impurities in the compound worsen the chemical-technological separation process. It is increasing the corrosive effect of the salt melt on the materials of technological equipment [1]. Aluminum oxides, oxychlorides appear, because of the high affinity of aluminum for oxygen. As a result, the oxygen content of the compound should be monitored. Quantitative control is conveniently carried out by the reductive melting method.

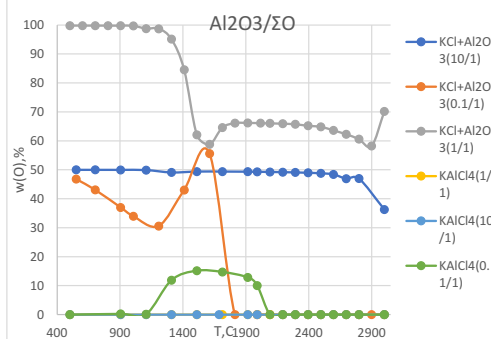
The method is based on the conversion of sample oxygen into the gas phase in the form of carbon monoxide in an inert gas atmosphere in a graphite crucible with a cap [2]. there is an overestimation of the oxygen content in the sample resulting from the hygroscopic nature of the compound. Therefore, the analysis is carried out in an inert atmosphere. you need to consider the formation of oxygen-containing components ( $\text{Al}_2\text{O}_3$ , etc.) to find the right temperature. Oxygen converted into carbon monoxide in small amounts if not enough oxygen interacts with the crucible. We see this as a result of the simulation (Fig. 1-3). It was carried out in the form: the first half of the sample reacts with the carbon of the crucible, the second half - with the gases released during the reaction. We use a crucible with a cap to obtain an excess of carbon in the system (Fig. 4).



**Figure 1.** carbon monoxide produced in the systems



**Figure 2**  $\text{AlClO(g)}$  produced in the systems



**Figure 3.** aluminum oxide produced in the systems



**Figure 4.** Crucible with cap

Simulation results of 2 systems: with synthesized  $\text{KAICl}_4$  and with a mixture of  $\text{Al}_2\text{O}_3 + \text{KCl}$  powders (non-hygroscopic system) were performed in the HSC 6.0 software. The amount of oxygen in the systems is taken as 1%. Carbon is 10 times more, 10 times less, the same amount [3]. The inert gas is calculated from the conditions of thermodynamics. For comparison, experiments were carried out on a Horiba emga 620W gas analyzer in the manual loading mode in a crucible with a cap. The non-hygroscopic mixture was previously ground to homogeneity and dried. Synthesis and packaging in  $\text{KAICl}_4$  tin capsules were performed in an inert box. The experimental data on the oxygen reading were similar to the simulation data at 10 times the carbon excess.

## References

- [1] Kudyakov V.Ya., Filatov E.C, Zaikov Yu. P. Met. For the preparation of potassium chloraluminum melt for the separation of zirconium and hafnium chlorides **2011**, 3-7
- [2] Vasserman A.M., Kunin L.L, Surovoi Yu.N. Determination of gases in metals **1976**, 250-278, 284-295
- [3] Zayzeva P.V. A study of the thermochemical processes of element atomization and molecule formation in conventional atomizers **2016**, 98-106.

# AMPEROMETRIC DETERMINATION OF FERRATE (VI) IN AQUEOUS SOLUTIONS

*Pantin A.V.<sup>1</sup>, Navolotskaya D.V.<sup>1</sup>*

<sup>1</sup>Saint Petersburg State University, Saint Petersburg, Russia

Student

[st075945@student.spbu.ru](mailto:st075945@student.spbu.ru)

In the past decade, a tetraoxy iron ( $\text{FeO}_4^{2-}$ ) with the highest oxidation state (+6) of iron, ferrate (VI), commonly known as ferrate has been of tremendous interest because of its high redox potential  $E^0 = +2.2 \text{ V}$  to  $+0.7 \text{ V}_{\text{SHE}}$  in acidic and alkaline media [1-3]. This characteristic makes ferrate as an efficient oxidant as well as a disinfectant for the destruction of a wide range of toxins and the inactivation of pathogens in water. The reaction of ferrate with pollutants forms nontoxic  $\text{Fe}(\text{OH})_3$ , which is a good coagulant. Moreover, the oxidation of water pollutants by ferrate does not lead to the formation of toxic by-products. That's why ferrate is often referred to a «green chemical».

Among the existing methods for the synthesis of ferrate (VI), the most simple, safe and easily automated method is the electrolysis method of synthesis. We synthesized a solution of sodium ferrate (VI) by electrolysis dissolution of iron anodes in an aqueous alkali solution. It was shown that the synthesized solutions are unsuitable for storage and transportation due to the low stability of ferrate (VI): in 4 hours at room temperature, the concentration of ferrate decreases by a quarter, for a month of storage at  $+4^\circ \text{C}$  and at  $-18^\circ \text{C}$  - by a third. Therefore, within the framework of the international scientific project "OneDrop", we are creating a mobile plant for water purification, the heart of which is an electrolyzer for the continuous synthesis of ferrate (VI) at the place of its consumption.

For water purification, the synthesized ferrate solution is added to the treated water in portions. To assess the completion of the oxidation process of pollutants, it was necessary to develop a method for detecting the first excess portion of ferrate. Amperometry was chosen as the analysis method. The optimum measurement conditions were selected using the method of cyclic voltammetry. A 20% aqueous NaOH solution served as a background solution. The electrochemical cell consisted of three electrodes - a working platinum electrode, a platinum auxiliary electrode, and a silver chloride reference electrode. The detection potential is  $-0.4 \text{ V}$ .

The analytical signal (i.e. current) at this potential linearly depends on the concentration of ferrate (VI) in the entire studied concentration range: from  $7.5 \cdot 10^{-5}$  to  $7.1 \cdot 10^{-4} \text{ M}$ . The detection limit of ferrate (VI), calculated by  $3\sigma$ -criterion was  $2 \cdot 10^{-7} \text{ M}$ . Experiments verifying this method with model solutions of contaminated water and with real water samples were carried out.

## References

- [1] E. N. Arakcheev, V. E. Brunman, M. V. Brunman, A. V. Konyashin, V. A. Dyachenko, and A. P. Petkova, "Complex technology for water and wastewater disinfection and its industrial realization in prototype unit," *Gig. i Sanit.*, **2017**.
- [2] Y. R. Song and J. W. Ma, "Development of ferrate(VI) salt as an oxidant and coagulant for water and wastewater treatment," *Appl. Mech. Mater.*, vol. 361–363, pp. 658–661, **2013**.
- [3] D. Tiwari and S.-M. Lee, "Ferrate(VI) in the Treatment of Wastewaters: A New Generation Green Chemical," in *Waste Water - Treatment and Reutilization*, **2011**.

Acknowledgements. This work was supported by the South-East Finland- Russia CBC Programme 2014-2020 as part of OneDrop project (project # KS1648).

# MICROEXTRACTION OF ZEARELENONE FROM FOOD SAMPLES USING DEEP EUTECTIC SOLVENTS

*Pavlova K.V.<sup>1</sup>, Pochivalov A.S.<sup>1</sup>, Bulatov A.V.<sup>1</sup>*

<sup>1</sup>Saint Petersburg State University, Saint Petersburg, Russia

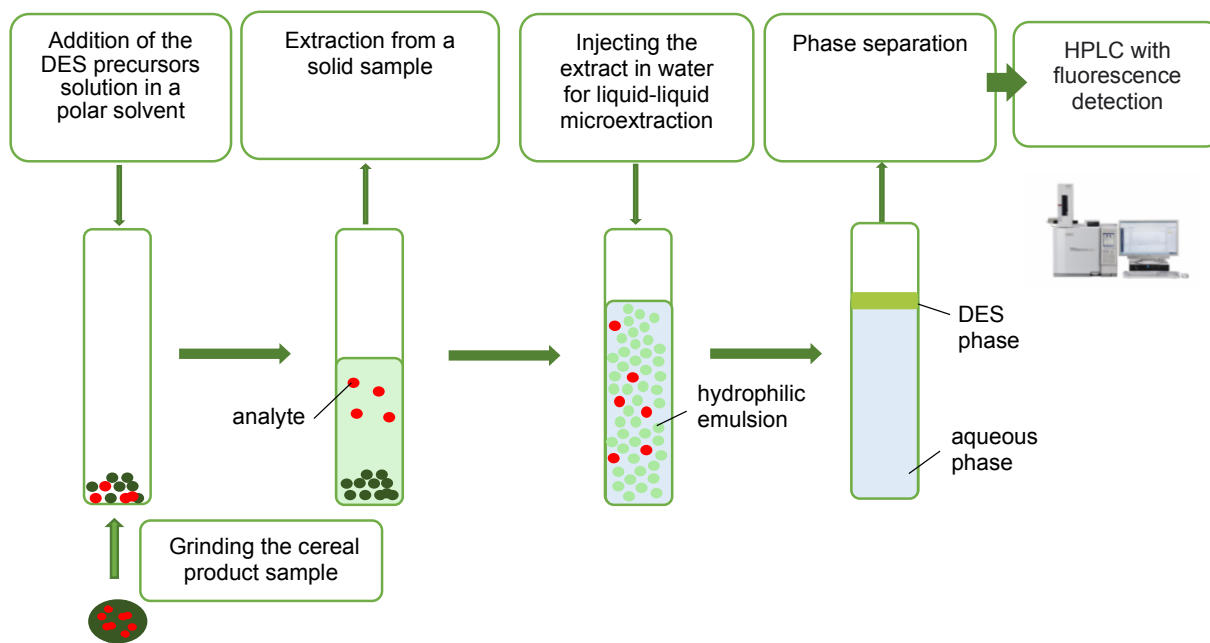
Student

[st067859@student.spbu.ru](mailto:st067859@student.spbu.ru)

Zearalenone is one of the most common mycotoxins produced by *Fusarium* fungi. It has a nonsteroidal estrogenic effect on living organisms and primarily affects crops growing in a humid climate as well as cereal products. In addition, this mycotoxin does not degrade during storage or heating. Thus, it is important to control zearalenone content in food of plant origin. Such matrices are complex and contain many interfering components, so the analyte should be extracted and preconcentrated for further analysis.

Deep eutectic solvents (DESs) have been proven to be an environmentally safe alternative to toxic organic extractants. They consist of hydrogen bond acceptor and hydrogen bond donor and are liquid at room temperature. Composition of DES can be easily varied which allows tuning its properties for selective and efficient extraction of the target compound. In this study, hydrophobic DESs based on menthol and long-chain alcohols were studied for the separation of zearalenone from cereal products for the first time.

The suggested sample preparation approach includes two steps (Figure 1). The first one is aimed to extract the analyte into the solution of DES precursors in a polar solvent. In this case interactions with menthol and long-chain alcohol, such as hydrogen bonding, can speed up the process and improve its efficiency. The second step includes injection of the obtained supernatant into deionized water for dispersive liquid-liquid microextraction. The *in situ* formation of the DES phase microdroplets is observed throughout the entire volume of the sample leading to zearalenone preconcentration. The determination of the analyte is carried out by HPLC with fluorescence detection.



**Figure 1.** Schematic representation of sample preparation steps.

Acknowledgements. This work was supported by the Russian Science Foundation (project No 21-13-00020, <https://rscf.ru/project/21-13-00020/>).

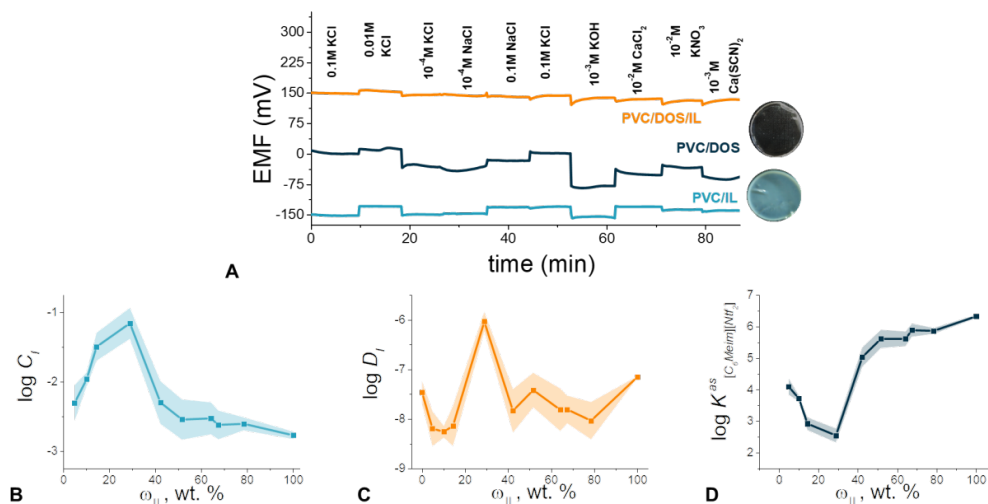


There is currently a surge of interest in ionic liquids (*ILs*) due to their unique characteristics, such as low volatility, thermal stability, and tunability of their properties. Moreover, they are suitable for polymeric ion-selective sensors due to their plasticizing and ion-exchanging properties.

*ILs* can act as a moderately lipophilic membrane electrolyte that has been shown to be essential for developing a reference electrode without a liquid junction (*LJF-REs*) [1]. As it can be seen in Fig. 1A, addition of 1-hexyl-3-methyl-1H-imidazol-3-ium bis[(trifluoromethyl)sulfonyl]azanide (*C<sub>6</sub>MeimNTf<sub>2</sub>*) to a polyvinylchloride (*PVC*) membrane plasticized with dioctyl sebacate (*DOS*) stabilizes electrode potential in various electrolyte solutions. If pure *IL* is used as a plasticizer, then the EMF readings are also quite consistent from solution to solution [2]. However, it remains unclear how *IL* behaves in the membrane phase and how it can affect the properties of sensors.

In this contribution, we studied the electrolytic behavior of the mentioned *IL* in *PVC* membranes plasticized with *IL-DOS* mixture. We prepared electrodes using the membranes with varied *IL* content in the plasticizing mixture. The membranes were polarized by a galvanostatic pulse, and from the resulting chronopotentiometric curves, the concentration of charged carriers (Fig. 1B), their mean diffusion coefficient (Fig. 1C), and the association constant of *C<sub>6</sub>MeimNTf<sub>2</sub>* were determined *in situ* in the polymeric phase [3].

The listed properties change non-monotonically with an increase in the *IL* content in the *PVC* matrix and reach their maximum/minimum at 25–30 wt.% of *IL* in the plasticizing mixture. Based on the obtained results, we can conclude that by varying the amount of *IL* it is possible to control the properties of sensor *PVC* membranes: their resistance, viscosity, and polarity. For the first time, the association constants of *IL* in a polymeric matrix were estimated: depending on the *IL* content,  $K_{as}$  value varied from  $1 \times 10^5$  to  $3.2 \times 10^6$ .



**Figure 1.** A) EMF of the cell containing the electrodes with membranes plasticized with pure *DOS*, pure *IL*, or their mixture. Inset photos: membranes plasticized with pure *DOS* (top) and pure *IL* (bottom). B, C, D: dependence of B) concentration of *C<sub>6</sub>MeimNTf<sub>2</sub>* ions; C) their mean diffusion coefficient; D) association constant, on the *C<sub>6</sub>MeimNTf<sub>2</sub>* content in the membrane.

The chronopotentiometric mode of measurements proposed here for evaluating the characteristics of *IL* can be adopted for studying the electrolytic properties of any organic electrolyte *in situ* in the polymeric sensor phase.

### References

- [1] A. Vincze et al., *Electrochem. Soc. Proc.* **1997**, 97–19, 550–555
- [2] T.M. Galiullin et al., *Electroanalysis* **2019**, 31 (9), 1708–1718
- [3] K.N. Mikhelson et al., *Sov. Electrochem.* **1988**, 24 (11), 1369

Acknowledgements. This work was supported by the Russian Science Foundation (project No 20-73-10033).

## QUALITY ASSESSMENT OF BIOLOGICAL GOODNESS OF THE HYDROLISATES

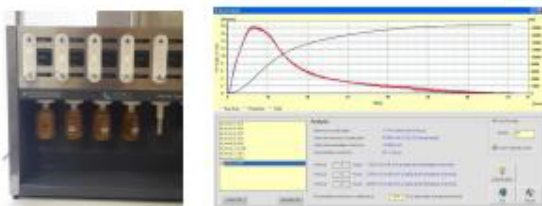
*Ponkratov A.S.<sup>1</sup>, Valeeva R.T., Ponkratova S.A.*

<sup>1</sup>Kazan National Research Technological University , Russia

PhD -student

[aponkratov@kstu.ru](mailto:aponkratov@kstu.ru)

The physical and chemical properties of the feedstock is of great importance for research the processes of hydrolysis and further for hydrolysate producing. Such physical properties as structure, water capacity and humidity determine growth rate, degree of hydrolysis and the yield of reducing substances. It is necessary to regard kinetics of hydrolysis reactions of polysaccharides for realize the process of hydrolysis for achieving the goals of obtaining hydrolysate. It is because the yield of reducing substances depends on speed ratio of their synthesis and disintegration, which are based on the physical and chemical conditions (temperature, pressure, hydrolysable agents concentrations, duty of water, stirring intensity, etc.).



**Figure 1.** Measurement of fermentation activity.

The practical interest in modelling of kinetics of plant raw material hydrolysis because the received data allow to choose the process optimal modes, predict the characteristics of the hydrolysis, which contributing higher yield and better quality of the target product. The simulation analysis gives the possibility to identify the main regularities and describe kinetics in all range of changes of technological parameters. The following goals are the technological system synthesis of quality assessment of the raw plant materials hydrolysates as recycled feedstocks for producing bioalcohol; create the methodic of the biological quality assessment of hydrolysate by measuring fermentation activity of the saccharomycetes.

The biological quality assessment of medium may be evaluated by measuring growth rates characteristics and fermentation activity with the results of experiments with complete mediums as Ryder's medium or modified Ryder's medium. The yeast'; fermentation activity may be determined by the rate of CO<sub>2</sub> yield, because as it was shown that yield of CO<sub>2</sub> and ethanol's yield are stoichiometric linked in the ratio. Also measuring of fermentation activity in the test seeding (yeast culture which was cultivated at reproducible constant environment) allows to control must's quality. Also we control growth activity of the seed material in the test synthetic medium with predetermined composition.

APPLICATION OF CHEMOMETRIC ALGORITHMS FOR THE DETERMINATION OF La, Fe, Al  
IN THE COMPOSITION OF HYDROCARBON CRACKING CATALYSTS

*Puzhel A.O.*<sup>1</sup>, *Vlasova I.V.*<sup>1</sup>

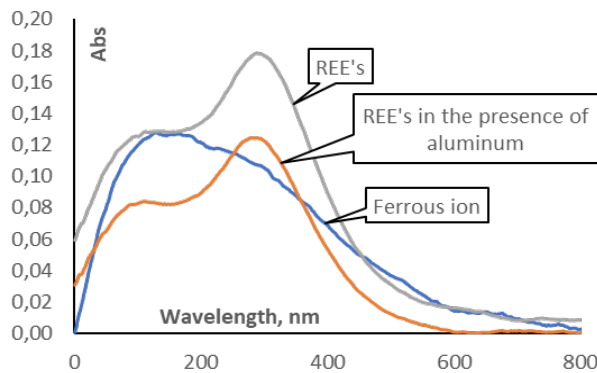
<sup>1</sup>Dostoevsky Omsk State University, Omsk, Russia  
[a.o.b.solveig@gmail.com](mailto:a.o.b.solveig@gmail.com)

Technologies for extracting REE from secondary raw materials are becoming more widespread. The use of zeolite cracking hydrocarbons catalysts for is promising. After desilicization using ammonium fluoride, the catalyst residue contains the main components - compounds of aluminum, iron, and rare earth elements [1]. Relevant objective is to develop a simple and rapid method for determining the listed ions, which would be available for most laboratories. The present work is devoted to the solution of this problem. It was found that in an acidic environment, Fe, as well as La, forms stable complexes with Arsenazo III. Additional studies of La, Fe, Al mixtures revealed the following problems: first, the absorption of a mixture of Fe and La complexes turns out to be nonadditive. For this reason, the absorption coefficients of the La and Fe complexes were calculated from the spectra of their mixtures of known composition. The optimal composition of the mixtures was found using the program "Optic-MLR", GENERATOR module [2], and is shown in Table 1

**Table 1.** Concentrations of ions of aluminum, iron, lanthanum in model solutions

	Threshold concentrations, mcg / ml		The compositions of the mixtures calculated by the Optical MLR program, (mcg/ml)		
	нижний	верхний	1	2	3
Al	1,1760	2,3520	1,176	2,352	2,352
Fe	0,1030	2,0600	2,060	0,103	0,103
La	0,1535	3,8300	0,154	3,830	0,154

Secondly, Al does not interact with Arsenazo III, but in its presence, the absorption of the La complex significantly decreases. Therefore, two sets of coefficients were calculated for the La complexes – in the absence and in the presence of Al. As can be seen from the data in Fig. 1, the spectra of the La and Fe complexes overlap over the entire wavelength range, and the type of the La absorption spectrum in the presence of Al does not change, only its intensity changes.



**Figure 1.** Specific absorption coefficients of complexes of iron, lanthanum, and lanthanum in the presence of aluminum, with Arsenazo III

The analysis of mixtures with overlapping absorption spectra can be performed using chemometric algorithms. We applied the method of multiple linear regression (MLR) using the calculated absorption coefficients. The method allows you to find the concentrations of REE and Fe separately, as well as their sum. To determine Al, a decrease in the absorption of the La complex was used. It was found that the decrease in absorption is linearly related to the concentration of Al. We prepared a series of model solutions with variable contents of La, Fe, and Al, performed a regression analysis, and found the coefficients  $k_i$  for an equation of the form  $C_{Al} = \sum k_i A_i$ , ( $A_i$  is the optical density at 7 wavelengths in the range 605-665 nm), which allows us to calculate the concentration of aluminum  $C_{Al}$ . All concentration calculations can be carried out in Excel. The relative error in the quantitative determination of components did not exceed 10%.

#### References

- [1] Puzhel A. O., Borisova V. A., Osipov A. R., Petlin I. V., Kiselev A. D., Adeeva L. N. Russian Journal of Non-Ferrous Metals, **2021**, 62, 2, 174–178.  
[2] Vlasova I.V., Shelpakova A.S., Dobrovolsky S.M., Fisenko A.V. Analitika i kontrol. - **2009**. 14. 3.153–157.

# INFLUENCE OF ORTHO-SUBSTITUENTS ON ELECTROCHEMICAL PERFORMANCE OF POTENTIOMETRIC MEMBRANE SENSORS BASED ON DIAMIDES OF DIPICOLINIC ACID

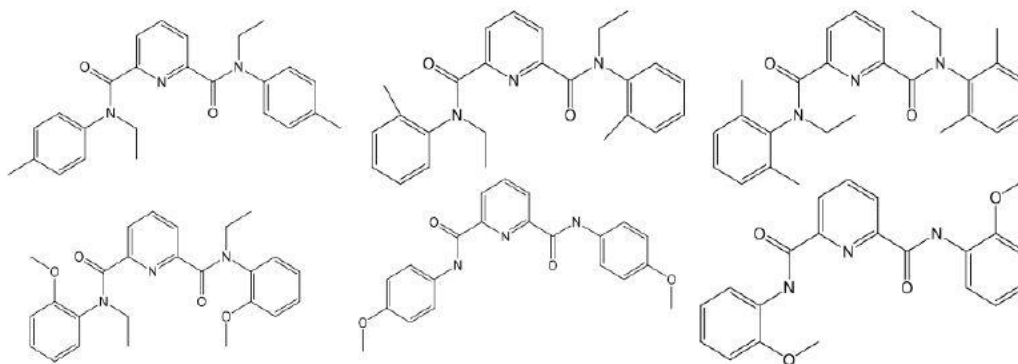
*Ren Y., Kirsanov D.O.*

Institute of Chemistry, St. Petersburg State University, St. Petersburg, Russia  
[yingchaoren@yandex.ru](mailto:yingchaoren@yandex.ru)

Potentiometric sensor arrays were shown to be a promising tool for analysis of technological solutions in spent nuclear fuel (SNF) reprocessing cycle [1]. The development of such arrays requires the sensors with pronounced electrochemical sensitivity towards lanthanides and actinides – the main target analytes in SNF. In our previous studies it was demonstrated that the employment of substances suggested as ligands in liquid-liquid extraction allows construction of the potentiometric sensors with required characteristics [2]. Dipicolinic acid diamides have confirmed potential in the development of such sensors; however, the influence of the substituents on the sensor performance in these compounds was not explored yet.

This study aims to fill this gap and to investigate the influence of substituents in diphenyl diamides of pyridine-2,6-dicarboxylic acid on their performance as sensor membrane active compounds in potentiometric sensors with plasticized polymeric membranes.

Six plasticized polymeric sensor membranes were prepared using synthesized diamides as membrane active compounds. The polymeric membrane matrix of electrodes was composed of poly(vinyl chloride) (PVC) (33 wt%) and 2-nitrophenyl octyl ether (NPOE) as a plasticizer (64–65 wt%). The acidic form of chlorinated cobalt dicarbollide (CCD) was used as cation-exchanger (10 mmol/kg). In order to evaluate the sensitivity and selectivity of the developed sensors potentiometric measurements in aqueous solutions of mono- ( $\text{Na}^+$ ,  $\text{K}^+$ ,  $\text{Cs}^+$ ), di- ( $\text{Ca}^{2+}$ ,  $\text{Sr}^{2+}$ ,  $\text{Ba}^{2+}$ ,  $\text{Co}^{2+}$ ,  $\text{Ni}^{2+}$ ,  $\text{Cu}^{2+}$ ,  $\text{Zn}^{2+}$ ,  $\text{Cd}^{2+}$ ,  $\text{Pb}^{2+}$ ) and trivalent metal ( $\text{Fe}^{3+}$ ,  $\text{Sc}^{3+}$ ,  $\text{Y}^{3+}$ ,  $\text{La}^{3+}$ ,  $\text{Ce}^{3+}$ ,  $\text{Pr}^{3+}$ ,  $\text{Nd}^{3+}$ ,  $\text{Sm}^{3+}$ ,  $\text{Eu}^{3+}$ ,  $\text{Gd}^{3+}$ ,  $\text{Tb}^{3+}$ ,  $\text{Dy}^{3+}$ ,  $\text{Tb}^{3+}$ ,  $\text{Er}^{3+}$ ,  $\text{Lu}^{3+}$ ) nitrates were performed. It was shown that the developed sensors provide stable and reproducible response towards varieties of metals relevant for SNF reprocessing. The details will be reported in the presentation.



**Figure 1.** Six compounds employed in the sensor membranes.

## References

- [1] Agafonova-Moroz M., et al. *Radioanal. Nucl. Chem.* **2019**, 323, 605–612
- [2] Oleneva E., et al. *Sensors Actuators, B Chem.* **2019**, 288, 155–162

# DETERMINATION OF SULFONAMIDES IN URINE SAMPLES BASED ON SCHIFF BASES FORMATION IN NATURAL DEEP EUTECTIC SOLVENT MEDIA

*Shakirova F.M., Shishov A. Yu., Bulatov A. V.*

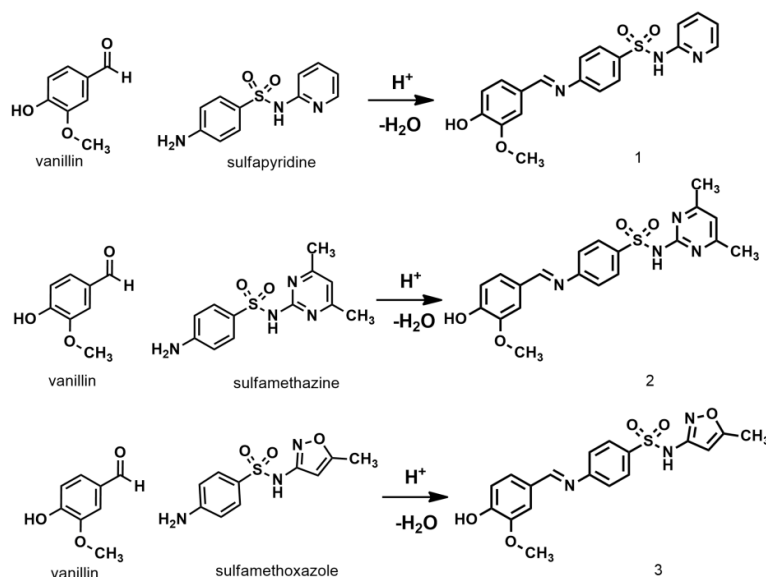
Saint Petersburg State University, Saint Petersburg, Russia

PhD student

[shakirovafiruza@mail.ru](mailto:shakirovafiruza@mail.ru)

Sulfonamides are broad-spectrum antimicrobials which are widely used for the treatment of various bacterial infections such as urinary tract infections, ear infections and bronchitis. To improve therapeutic effect and exclude side effects of sulfonamides the monitoring of the drugs in biological fluids is required. In this study, the method of determination of sulfonamides (sulfamethoxazole, sulfamethazine and sulfapyridine) in urine samples by usage of natural deep eutectic solvents based on vanillin and thymol is developed.

Deep eutectic solvents (DESs) as a class of environmentally friendly solvents, are increasingly being used in analytical chemistry as effective extractants for the separation and preconcentration of various analytes from complex matrixes. In this research it was established that vanillin as precursor of NADES promoted extraction of sulfonamides from aqueous phase due to formation of hydrophobic derivatives – Schiff bases (Figure 1). The efficiency of extraction of polar sulfonamides in the extractant phase was increased due to the formation of hydrophobic Schiff bases. The extraction mechanism of sulfonamides was based on the formation of colored Schiff bases in the presence of vanillin acted as derivatization reagent and precursor of natural deep eutectic solvent. The obtained derivatives in NADES phase were colored and stable in time. The formation of the Schiff bases was confirmed by mass spectrometry.



**Figure 1.** The formation of Schiff bases

For the microextraction procedure a Lab-In-Syringe concept was utilized. Procedure assumed mixing sample and natural deep eutectic solvent phases into a syringe of a flow system followed by UV-Vis detection of separated extract phase containing colored Schiff base. Under optimal automated conditions the limits of detection were 0.06, 0.1, and 0.06 mg L<sup>-1</sup> for sulfapyridine, sulfamethoxazole and sulfamethazine. The proposed automated procedure permitted the routine determination of sulfonamides in human urine samples to be achieved in less than 8 min. Sample throughput was 7 samples h<sup>-1</sup>.

Acknowledgements. This work was supported by the Russian Science Foundation (project No. 20-73-00043)

## CANCER DIAGNOSIS BY NIR SPECTROSCOPY AND AQUAPHOTOMICS

Surkova A.<sup>1,2\*</sup>, Bogomolov A.<sup>2</sup>, Bibikova O.<sup>3</sup>, Zabarylo U.<sup>3</sup>, Artyushenko V.<sup>3</sup>, Hocotz T.<sup>4</sup>,  
Legin A.<sup>1</sup>, Kirsanov D.<sup>1</sup>, Muncan J.<sup>5</sup>, Tsenkova R.<sup>5</sup>

<sup>1</sup> Institute of Chemistry, St. Petersburg State University, St. Petersburg, Russia;

<sup>2</sup> Samara State Technical University, Samara, Russia;

<sup>3</sup> Art photonics GmbH, Berlin, Germany;

<sup>4</sup> Charité – Universitätsmedizin Berlin, Germany;

<sup>5</sup> Kobe University, Japan;

Young scientist

\* [a.surkova@spbu.ru](mailto:a.surkova@spbu.ru)

Early diagnosis of cancer reduces mortality of the patients and improves treatment outcome. There are established check lists and screening protocols (e.g., ultrasound of breasts or prostate), adapted for various ages and aimed to assessing oncological risks. However, these procedures are time-consuming, often invasive and non-pleasant for most patients, which lead to low effectiveness of current methods of early cancer diagnosis. Therefore, a non-invasive and fast method of cancer screening compatible with routine procedures, e.g., blood or urine analysis, is highly required.

Near infrared (NIR) spectra of biological fluids (blood, urine, etc.) contain information about various biologically important molecules (e.g. proteins, lipids, glucose) and are presumably capable to distinguish molecular changes in intact and tumorous cells. NIR fiber-optic spectroscopy provides fast measurements without difficult sample pretreatment and has a great potential for non-invasive or minimally invasive and inexpensive cancer screening [1]. However, there is no concerted strategy for spectral data analysis that hinders the wide application of NIR spectroscopy in clinical practice.

Aquaphotomics is a newly developed scientific discipline [2] that studies the role of water in biological systems. The NIR wavelength region around 680–2500 nm contains a lot of information about water molecular structure. Water molecules form hydrogen bonds between each other and with their surroundings, which makes water absorption bands in NIR region very sensitive to the sample composition. This study aims to extract information about water structure from NIR spectra of biological fluids (urine, plasma and serum of blood) taken from patients before and after different cancer surgery. The NIR absorbance spectra of the biofluids were acquired and studied using multivariate analysis and Aquaphotomics approach. The reported results can be potentially employed for characterization of biomaterials and cancer screening.

### References

- [1] Kondepati V. R., et al. *Anal. Bioanal. Chem.* **2008**, *390*, 125–139  
[2] Tsenkova R. J. *Near Infrared Spectrosc.* **2010**, *17*(6), 303–313

Acknowledgements. This study was supported by the President's grant #MK-2192.2021.4.

# SURFACE-ENHANCED RAMAN SPECTROSCOPY OF SNAKE VENOM NEUROTOXIN

*Tagirova M.R.<sup>1,2</sup>, Mozhaeva V.A.<sup>1,3</sup>, Kudryavtsev D.S.<sup>1</sup>*

<sup>1</sup>Shemyakin-Ovchinnikov Institute of bioorganic chemistry, Moscow, Russia

<sup>2</sup>Moscow State University, Moscow, Russia

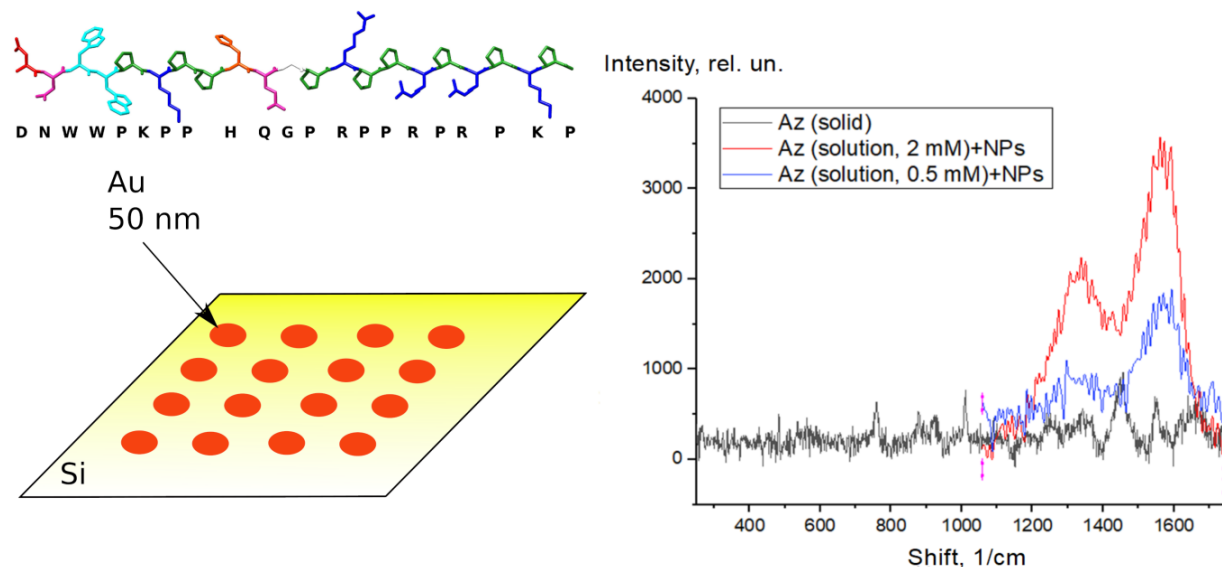
<sup>3</sup>Prokhorov General Physics Institute, Moscow, Russia

Student

[tagirova5353@yandex.ru](mailto:tagirova5353@yandex.ru)

Venomous snakebites claim the lives of more than 138,000 people every year around the world. An urgent problem in providing medical assistance to a victim is the rapid determination of the characteristics of the poison (type of animal, type of action). The main stage is the detection and identification of specific toxins that make up the poisons. The enzyme-linked immunosorbent assay usually used for this purpose has some disadvantages (requirements for the amount of sample, time to perform the assay). Surface-enhanced Raman spectroscopy (SERS) can help to overcome these limitations. Currently, the literature does not describe methods for identifying peptide neurotoxins using Raman spectroscopy methods. However, the development and implementation of such a method for rapid detecting and identifying peptide neurotoxins will help improve the situation by providing adequate medical care for snake bites.

Gold nanoparticles (GNP) with diameter 50 nm were obtained by citrate reduction process and used to get structured film of nanoparticles on silicon wafer in presence of cetrimonium bromide (CTAB). Raman spectra of azemiopsin, a peptide toxin from venom of *Azemiops fea*, were recorded either from droplets of azemiopsin solution or from desiccated droplets on GNP film on silica substrate (Fig. 1).



**Figure 1.** Primary structure of azemiopsin; scheme of obtained nanostructured film; surface-enhanced raman spectra of azemiopsin: black line – without GNP, red and blue lines – different concentrations of the toxin after drying on the GNP film.

Obtained nanostructured film enhanced signals of Raman spectra of azemiopsin. Detection of the toxin using this method is possible in concentrations of azemiopsin 125  $\mu$ M and above and less than 13 ng of toxin substance. According to the data of amino acids Raman spectra, the peak in the range of 1550  $\text{cm}^{-1}$  belongs to tryptophan, the closest to the CTAB-covered GNPs part of the toxin.

# INFLUENCE OF OSTARINE AND ECDYSTERONE USAGE ON MALE AND FEMALE STEROID PROFILE

Podolskiy I.I.<sup>1</sup>, Mochalova E.S.<sup>2</sup>, Temerdashev A.Z.<sup>3</sup>

<sup>1</sup>Bruker Ltd., Moscow, Russia

<sup>2</sup>National Antidoping Laboratory (Institute) of the Lomonosov Moscow State University, Moscow, Russia

<sup>3</sup>Kuban State University, Krasnodar, Russia

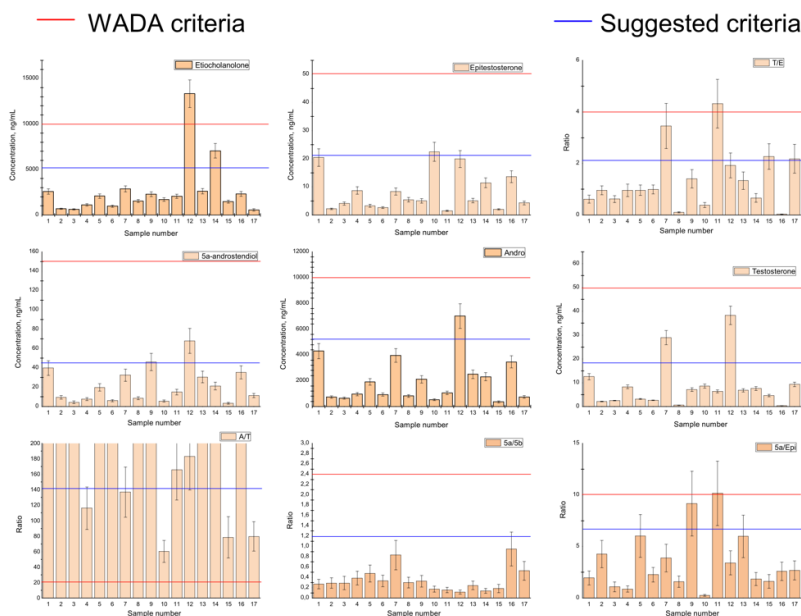
[TemerdashevAZ@gmail.com](mailto:TemerdashevAZ@gmail.com)

The influence of using ostarine on steroid profile of men and women was shown. This research is based on a qualitative and quantitative analysis results of more than 10 thousand urine samples free from WADA prohibited compounds in order to obtain a statistically significant representative sampling as well as 17 female and 13 male ostarine (or its metabolites) positive samples and 532 male and 245 female samples with positive testing results on ecdysterone.

Quantification of androgenic steroids was performed with gas chromatography coupled with tandem mass spectrometric detection after derivatization of the samples with the mixture of dithiothreitol, ammonia iodide and N-Methyl-N-(trimethylsilyl)trifluoroacetamide [1–3].

The study found a significant change of the content of androgenic steroids in female urine after ostarine administration was established, while in male urine samples this effect was not observed. It is noted that the use of ecdysterone doesn't significantly affect the content of androgenic steroid hormones in either men or women.

Based on the considered number of samples free from WADA prohibited compounds, more stringent permissible limits for the content of androgenic steroids for female are proposed, which don't lead to a significant increase in the number of false positive results.



**Figure 1.** Observed concentrations of androgenic steroids in female urine with confirmed ostarine presence.

## References

- [1] WADA Athlete Biological Passport Operating Guidelines. Available at: [https://www.wada-ama.org/sites/default/files/resources/files/guidelines\\_abp\\_v71.pdf](https://www.wada-ama.org/sites/default/files/resources/files/guidelines_abp_v71.pdf) (accessed 30 May 2020)
- [2] Mohd Rodhia A., Abdul Latif M.N.F., Salima S.A., Abdul Manaf N., Muhamad Salhimi S., Ismail M.N., *Sci. Sports* **2019**, *34*, 52–55
- [3] Häkkinen M.R., Heinosaalo T., Saarinen N., Linnanen T., Voutilainen R., Lakka T., Jääskeläinen J., Poutanen M., Auriola S., *J. Pharm. Biomed. Anal.* **2018**, *152*, 165–172

Acknowledgements. This work was supported by Russian Foundation for Basic Research (project No 19-43-230004 p\_a) and Russian Ministry of Science and Higher education (project FZEN-2020-0022), and Ecoanalytical center of collective usage (Kuban State University).



# THE STUDY OF THE EXTRACTION OF LONG-LIVED RADIONUCLIDES BY POLYFUNCTIONAL COMPOUNDS IN PERSPECTIVE FLUORINATED DILUENTS

*Timoshenko V.V.<sup>1</sup>, Ermolenko Y.E.<sup>1</sup>, Smirnov I.V.<sup>1,2</sup>*

<sup>1</sup>Saint Petersburg State University, Saint Petersburg, Russia

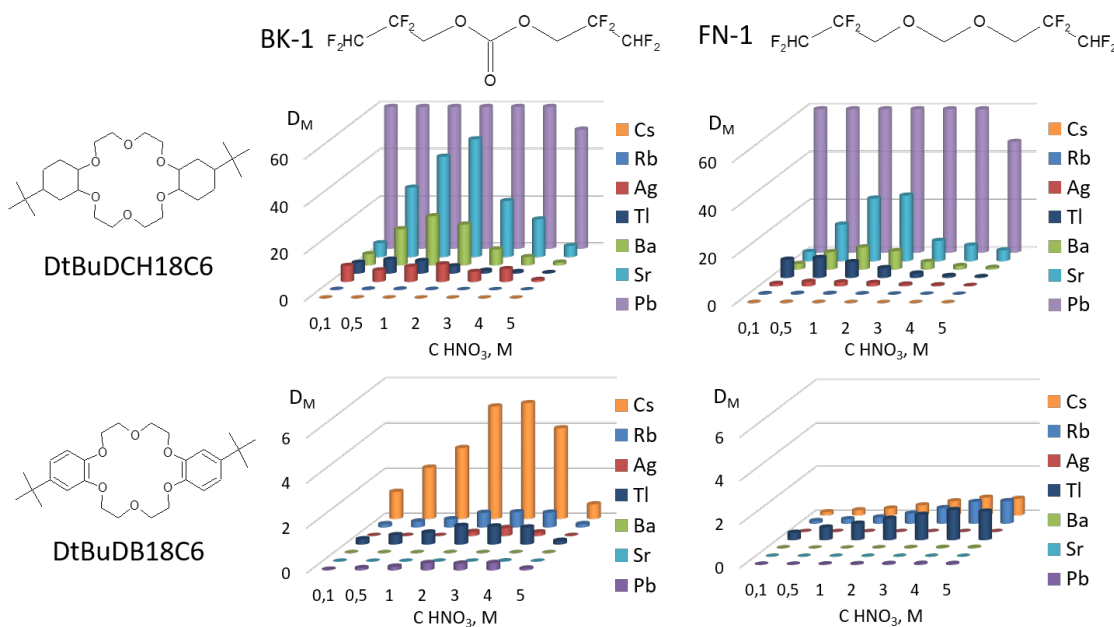
<sup>2</sup>Khlopin Radium Institute, Saint Petersburg, Russia

PhD Student

[v.v.timoshenko@spbu.ru](mailto:v.v.timoshenko@spbu.ru)

One of the most promising areas of modern radiochemistry is the creation of a general technology for the extraction processing of spent nuclear fuel (SNF) and fractionation of high-level waste (HLW). An increased interest in the separation of isotopes of cesium <sup>137</sup>Cs and strontium <sup>90</sup>Sr from spent nuclear fuel in recent years has grown in Russia in connection with the emergence of the concept of a balanced nuclear technological cycle "Balanced NFC". To solve the above problem, it is necessary to carry out a targeted search for promising extraction systems, with the use of which it is possible to individually isolate valuable radionuclides [1-2].

In the targeted extraction of cesium-137 and strontium-90 from SNF products, difficulties arise due to the competing complexation and co-extraction of the present stable elements. To study their effect and evaluate the separation efficiency, a series of experiments was carried out using four extraction systems based on modified crown ethers in new fluorinated solvents: bis-tetrafluoropropylformal (FN-1 = 1,1,2,2,8,8,9, 9-octafluoro-4,6-dioxanonane) and bis-tetrafluoropropyl carbonate (BK-1 = 2,2,3,3-tetrafluoropropan-1-ol carbonate) [3]. The obtained data set was used to construct the dependences of the distribution coefficients of cesium and strontium on the acidity of the medium.



**Figure 1.** Dependence of the distribution coefficients of metals (Pb(II), Sr(II), Ba(II), Tl(I), Ag(I), Rb(I), Cs(I)) on the concentration of HNO<sub>3</sub> for the extraction system DtBuDCH18C6 & DtBuDB18C6 0.05 M in BK-1 & FN-1.

This results provide the fact that cesium is significantly extracted only by systems based on DTBDB18C6 (di-tert-butylidibenzo-18-crown-6). At the same time, strontium is well extracted only by systems based on the DTBDCH18C6 (di-tert-butylidicyclohexyl-18-crown-6). In the course of the study, fundamentally new extraction systems were tested. They can be recommended for further practical application in the targeted extraction of cesium and strontium from SNF and HLW.

## References

- [1] Chao Xu, Wang J., & Chen J. *Solvent Extraction and Ion Exchange* **2012**, 30, 623–650
- [2] Sasaki Y., Morita K., Kitatsuji Y., Ito K., et al. *Solvent Extraction and Development* **2018**, 28, 121-131
- [3] Babain V., Alyapyshev M., Voronaev I., et al. *Solvent Extraction and Ion Exchange* **2020**, 39, 255–270

Acknowledgements. This work was supported by the Russian Science Foundation (project No 20-13-00143).

# INVESTIGATION OF INTERACTIONS OF DIHYDROXYFUMARIC ACID WITH DPPH IN DIFFERENT SOLVENTS

*Vicol C.<sup>1</sup>, Cimpoiu C.<sup>2</sup>, Duca G.<sup>1</sup>*

<sup>1</sup>Institute of Chemistry, Chisinau, Republic of Moldova

<sup>2</sup>Babes-Bolyai University, Cluj-Napoca, Romania

[crina.smigon@gmail.com](mailto:crina.smigon@gmail.com)

Dihydroxyfumaric acid (DHF) is a natural compound with strong antioxidant properties [1]. DHF is known to be present in grapes [2] in small quantities, being involved in the metabolism of the fruits during the ripening period [3]. Wines contain a low concentration of DHF because of fast decomposition in the aerobic conditions [3]. Added in small quantities (1 – 10 mM), dihydroxyfumaric acid can improve the taste and smell of wines, by inhibiting the oxidation of characteristic polyphenols [4, 5].

The contribution of DHF along with other antioxidants is known to be positive for the quality of the wines, and, respectively, to the total antioxidant power of this beverage [4, 6]. However, not only the presence of the reducing compound is important for the total antioxidant activity of wines. Data reported showed that the species less active as reducing agents have also a significant contribution. For example, organic acids like tartaric, malic, citric acids found in big quantities in grapes and wines can enhance the reducing power of the main antioxidants via the synergic interactions [7, 8].

In this study, the influence of different solvents on the antioxidant activity of less studied compound DHF against the free radical 2,2-diphenyl-1-picrylhydrazyl (DPPH) was studied. Reaction of DPPH with DHF was investigated in 98% ethanol and in wine simulated matrix, which basically consists of 5g/L tartaric acid in ethanol-water mixture (12%v/v) with an adjusted pH to 3.2 [9].

The spectrophotometric measurements were performed by using a stopped-flow system on a Biologic SFM-300 system equipped with three syringes and capable of sequential mixing, with a high-speed diode array detector. Stopped-flow data were analyzed within the SPECFIT32 software package (BioLogic Science Instruments, Seyssinet-Pariset, France) using Singular Value Decomposition (SVD) and global multiexponential fitting of the SVD treated data, with the spectra fitted to simple kinetic models using Levenberg–Marquardt or Simplex algorithms.

The results showed that the wine matrix has low antioxidant activity against DPPH, the efficiency being of about 3%. Taking into consideration the high concentration of the main constituent of the matrix – tartaric acid, the low DPPH radical scavenging activity of this compound can be underlined.

From the recorded spectra, it was found that in ethanol DHF has a lower antioxidant activity, the maximum efficiency being of 16% for the DHF/DPPH molar ratio of 3.2. Contrary to that, in the wine matrix the antioxidant activity of DHF is much higher. The highest concentration of DHF reduces the free radical up to 80%. The observed rate constants ( $k_{obs}$ ) were higher in the wine matrix than in ethanol, thus, the  $k_{obs}$  for the reactions of DPPH with DHF increase 10 times in wine model solution.

The enhancement of the antioxidant activity in wine matrix can be due either to the ethanol-water solvent mixture or to the presence of tartaric acid. Many authors [7-10] reported synergetic combinations of a weak antioxidant like tartaric acid with strong antioxidants, the weaker antioxidant being able to regenerate the stronger one, thus improving the overall radical quenching ability of the system. The large values for the observed constants in the wine matrix can be determined by the presence of tartaric acid as a weak antioxidant that can have the capacity to regenerate DHF when the latter one is used against DPPH.

## References

- [1] Secara N. *Chem. J. Mold.* **2010**, *5*, 83–87
- [2] Duca G., Gonța M., Mereuța A. *The Role of Ecological Chemistry in Pollution Research and Sustainable Development*, Springer, Dordrecht, **2009**, pp. 197-207.
- [3] Secara N., Duca G., Vlad L., Macaev F. *Chem. J. Mold.*, **2011**, *6*, 29-44.
- [4] Liviu V. *Agricultura*, **2008**, *57*, 1–8.
- [5] García B., Ruiz R., Leal J. M. *J. Phys. Chem.*, **2008**, *112*, 4921–4928.
- [7] Vicol C., Duca G. *Rev. Șt., Inov., Cult. Art. „Akademos”*, **2020**, *56*, 39–43.
- [8] Lo Scalzo R. *Food Chem.*, **2008**, *107*, 40–43.
- [9] Comuzzo P., Battistutta F., Vendrame M., Páez M. S., Luisi G., Zironi R. *Food Chem.*, **2015**, *168*, 107–114.
- [10] Pedrielli P., Skibsted L.H. *J. Agric. Food Chem.*, **2002**, *50*, 7138–7144.

# INFLUENCE OF THE EXTRACTION METHOD ON THE COMPONENT COMPOSITION OF THE PHENOLIC NATURE OF WATER-ALCOHOLIC EXTRACTS *ECHINACEA PURPUREA* L.

Vinitskaya E.A., Chubukina T.K., Meshcheryakova E.E.

Kuban State University, Krasnodar, Russia

PhD student

[elenashilko94@gmail.com](mailto:elenashilko94@gmail.com)

Medicinal plants belonging to the *Asteraceae* family are characterized by antibacterial, antiproliferative, inhibitory and other properties [1]. A prominent representative of this family is *Echinacea purpurea* L., which is used as an herbal supplement in the treatment and prevention of a number of diseases, relieves migraine pain and anxiety, stimulates wound healing and strengthens the immune system [1]. The main form of practical application of these plants for phytotherapeutic purposes are aqueous-alcoholic extracts. Water-alcohol extracts from *Echinacea purpurea* L. for phytotherapy purposes, it's traditionally obtained by maceration [2] or boiling in a Soxhlet apparatus [3]. As alternative methods, we consider microwave extraction [4], ultrasonic extraction [5], and extraction under conditions of elevated temperature and pressure [5], which intensify the preparation of the sample. The relevance of the use of plants of the *Asteraceae* family is supported by a high level of sales, which, in combination with the displayed pharmacological properties, make echinacea an interesting object for research on assessing the content of components that form biological activity.

The aim of this work was a chromatographic study of various aqueous-alcoholic extracts of *Echinacea purpurea* L. to assess the effect of the extraction method on the component composition of the phenolic nature.

The objects of the study were samples of the herb *Echinacea purpurea* L. of various brands. The identification and determination of the target compounds was carried out using standard samples. The extraction of phenolic compounds from the samples was carried out using ultrasonic, microwave and subcritical extractions, and the extraction of components was also carried out under the conditions regulated by the corresponding Pharmacopoeia Monograph. The extragent in all methods was a water-ethanol mixture with a volumetric alcohol content of 70%. The obtained aqueous-alcoholic extracts were further analyzed using an LC 20 Prominence chromatograph with diode array and mass spectrometric detectors. Separation of analytes was carried out on a column Luna C18 100A, 250×2.0 mm, 5 µm with a column-guard C18 4 × 2.0 mm, 5 µm (Phenomenex, USA).

It was found that using the extraction process according to the pharmacopoeia article it's possible to extract the maximum amount of phenolic compounds from echinacea. In this work, the optimal conditions for subcritical extraction are selected – the extraction of 70% ethanol at a temperature of 120°C. It's worth noting that microwave and subcritical extraction are comparable to each other in terms of extraction efficiency and differ only in the duration of the process. The total content of phenolic compounds in terms of chicory acid in extracts obtained by the pharmacopoeia method was 26 mg / g, and by microwave and subcritical methods - 22 and 23 mg / g, respectively. Ultrasound extraction showed a minimum result of 13 mg / g.

A comparative analysis of echinacea samples grown in different territories was carried out. In this case, the total content of phenolic compounds in 70% water-alcohol extracts of *Echinacea purpurea* L. in terms of chicory acid is minimal in the samples of "Herbs of the Mountain Crimea", and the maximum in the raw materials provided by the company "Rodnye Travy". On the other hand, among all the studied samples, the highest content of rutin was found in the raw materials of "Herbs of the Mountain Crimea", which is probably due to the favorable effect on the accumulation of this compound of the height of the plant growth. Based on the obtained data, a coefficient is proposed that characterizes the quality of medicinal plant material.

## References

- [1] Sharif K.O.M., Tufekci E.F., Ustaoglu B., Altunoglu Y.C., Zengin G., Llorent-Martinez E.J., Guney K., Baloglu M.C. *Food Biosci.* **2021**, 41, 101005.
- [2] Pellati F., Epifano F., Contaldo, N., Bertaccini A., Bellardi M.G. *J. Agric. Food. Chem.* **2011**, 59, 10425-10434.
- [3] Lalone C.A., Rizshsky L., Hammer K.D.P., Kim M., Birt D.F. *J. Agric. Food. Chem.* **2009**, 57, 8820-8830.
- [4] Tsao R., Deng Z. *J. Chromatogr. B.* **2004**, 812, 85–99.
- [5] Rezaei E., Abedi M. *Pharm. Chem. J.* **2017**, 51, 471–475.

Acknowledgements. This work was supported by the Russian Foundation for Basic Research (project No 20-33-90045).

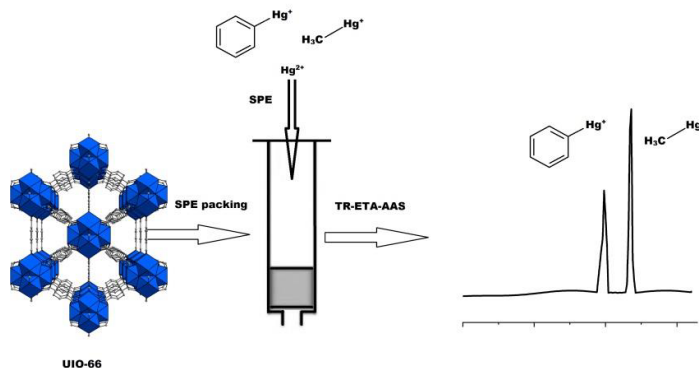
# UIO-66 METAL-ORGANIC FRAMEWORK APPLICATION FOR MERCURY SPECIATION USING SOLID PHASE EXTRACTION FOLLOWED BY DIRECT THERMAL RELEASE AND ETA-AAS DETECTION

Volynkin S.S.

<sup>1</sup>Nikolaev Institute of Inorganic Chemistry, Novosibirsk, Russia  
PhD Student  
[volynkin@niic.nsc.ru](mailto:volynkin@niic.nsc.ru)

Metal-organic frameworks (MOFs) are increasingly used in analytical chemistry for pre-concentration of trace elements followed by their determination using modern analytical techniques. MOFs can be considered as promising materials for their application in analytical chemistry [1]. These potential applications are implemented through the presence of the active centers, linkers, tunnels, high porosity and other structural features in MOFs, which provide the selectivity of the various species interactions with the active sites as well as a size selectivity required for their separation. Moreover, selectivities can be enhanced through modification which further expands the areas of their application using various approaches. However, there are a limited number of publications concerning the use of MOFs for speciation purposes, while their structural and functional features are perspective for the element species selective extraction and pre-concentration. The use of MOFs for the sample preparation and subsequent combination with the element-selective detection for the elements speciation is a successful solution to the problems associated to the study of transformation and transport of the most hazardous metals in environment. It is known that mercury refers to the most hazardous elements which species demonstrate different toxicity, migration routes and bioavailability as well. Consequently the development of new approaches for mercury speciation in environments remains an actual objective of analytical chemistry.

In present work a new methodology for inorganic and organic mercury speciation in water was proposed. This approach is based on pre-concentration using solid phase extraction (SPE) followed by their determination directly from the solid phase with the application of the thermal release – electrothermal- atomic- absorption technique (TR-ETA-AAS) [2]. An original SPE-procedure based on the use of UIO-66  $[Zr_6O_4(OH)_4(bdc)_6]$  in two different modes (non-modified and modified with cysteine) as a sorbent was designed [3]. In this work, it was demonstrated the possibility of mercury speciation in waters using combination of solid-phase extraction and the TR-ETA-AAS method, which includes the SPE of analytes using the UIO-66 MOF  $([Zr_6O_4(OH)_4(bdc)_6])$ . It was shown that the proposed approach allows shown that inorganic mercury ( $Hg^{2+}$ ), methylmercury ( $MeHg^+$ ) and phenylmercury ( $PhHg^+$ ) can be determined in waters using different modes of SPE at the level of  $0.06 \mu g \cdot L^{-1}$  directly from the solid phase of MOFs bypassing the desorption stage.



**Figure 1.** UIO-66 solid-phase extraction and TR-ETA-AAS determination of the mercury species.

## References

- [1] Rocío-Bautista, Taima-Mancera, Pasán, & Pino. Metal-Organic Frameworks in Green Analytical Chemistry // Separations. **2019**, 6(3), 33
- [2] O.V. Shuvaeva, M.A. Gustaytis, G.N. Anoshin, Mercury speciation in environmental solid samples using thermal release technique with atomic absorption detection. Anal. Chim. Acta. **2008**, 621, 148-154
- [3] K.A. Kovalenko, V.P. Fedin, A.K. Sagidullin, B.M. Orliogdo, V.A. Bolotov, A.S. Knyazev, I.N. Mazov, S.L. Gorbin, V.S. Mal'kov, Fast and scalable method of producing microporous terephthalate of zirconium (IV). Patent of RF № RU2719597C1. **2020**, Bul. № 12.

Acknowledgements. This work was supported by the Russian Science Foundation (project No 18-13-00203)

# POLY(ELLAGIC ACID)-MODIFIED ELECTRODE FOR THE DIRECT SELECTIVE QUANTIFICATION OF NARINGIN

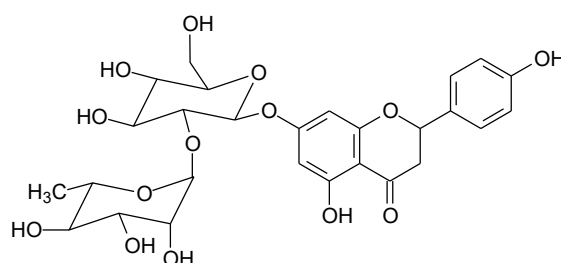
*Yakupova E.N., Ziyatdinova G.K.*

Kazan Federal University, Kazan, Russia

PhD student

[elviraepakupova96@mail.ru](mailto:elviraepakupova96@mail.ru)

Natural phenolics as part of daily human diet is of great interest and widely investigated. Being electrochemically active compounds, they are often determined in a foodstuff using electrochemical methods. Naringin (naringenin 7-O-neohesperidoside) (Figure 1) being the major flavanone of grapefruit [1] shows a wide spectrum of biological activity like antioxidant, anti-inflammatory, anticancer and cardiovascular protective [1-2]. It also strongly effects on the pharmacokinetics of a variety of pharmaceutical dosage forms in vivo via inhibition of the cytochrome P450 enzymes [3]. Therefore, reliable methods for naringin determination are required. Nevertheless, it is almost out of consideration in electroanalysis. Analytical characteristics and selectivity of naringin electrochemical determination can be further improved.



**Figure 1.** Naringin structure

Novel electrode based on layer-by-layer modification of multi-walled carbon nanotubes and electropolymerized ellagic acid has been developed for the direct quantification of naringin. Application of carbon nanotubes as platform for polymer deposition significantly increases the effective surface area and conductivity while polymeric film provides structural similarity to the analyte and the porous structure leading to the increase of determination sensitivity. Conditions of ellagic acid potentiodynamic electropolymerization (the monomer concentration, supporting electrolyte, potential scan rate and polarization window, the number of cycles) providing the best response of naringin have been found. Ellagic acid electropolymerization has to be performed from 10  $\mu\text{M}$  monomer by sevenfold cycling of potential in the range of 0.0 – 1.0 V at the scan rate of 100  $\text{mV s}^{-1}$  in phosphate buffer pH 7.0. The electrode surface has been characterized by SEM and electrochemical methods. The polymeric films exhibit porous structure with the shape of 30-50 nm spherical particles confirming successful modification of the electrode. The effective surface area of modified electrode is 9.6- and fold increased vs. glassy carbon electrode (GCE). The electrochemical impedance spectroscopy data show statistically significant decrease of the charge transfer resistance for the polymer-modified electrodes vs. GCE. Naringin electrooxidation parameters on poly(ellagic acid)-modified electrode have been found. Under conditions of differential pulse voltammetry in phosphate buffer pH 6.5, the linear dynamic ranges of 0.050-1.0 and 1.0-100  $\mu\text{M}$  with the detection and quantification limits of 14 and 47 nM, respectively, have been obtained that is much better than reported to date for other methods. The electrode selectivity towards naringin in the presence of inorganic ions, saccharides, hesperidin, ascorbic and phenolic acids has been proved that is important advantage of the approach developed. The practical applicability of the poly(ellagic acid)-modified electrode has been tested on the red grapefruit juices and a good agreement with the independent determination has been shown.

Thus, the novel highly sensitive and selective voltammetric method for the direct naringin quantification is characterized by simplicity of the electrode fabrication, cost-efficiency, reliability of the results obtained, and can be used in the routine practice for the screening of food samples as an alternative to chromatographic methods.

## References

- [1] Khan M.K., Zill-E-Huma, Dangles O. J. *Food Compos. Anal.* **2014**, *33*, 85-104
- [2] Yi L., Ma S., Ren D., *Phytochem. Rev.* **2017**, *16*, 479-511.
- [3] Ueng Y.F., Chang Y.L., Oda Y., Park S.S., Liao J.F., Lin M.F., Chen C. F. *Life Sci.* **1999**, *65*, 2591-25602

## MULTIPURPOSE DETECTOR BASED ON HIGH FREQUENCY INDUCTOR

*Yuskina E.A., Makarov N.A., Semenov V.G., Panchuk V.V., Kirsanov D.O.*<sup>1</sup>

<sup>1</sup>Saint Petersburg State University, Saint Petersburg, Russia  
Student Yuskina Ekaterina  
[lazyvelikaya@yandex.ru](mailto:lazyvelikaya@yandex.ru)

In this study we propose a very simple and low-cost detector which may have multiple analytical applications. The detector is based on the inductor coil connected to the generator of a high-frequency electric field (1-190 MHz). When a sample solution is introduced inside the coil as an inductor core, the receiver detects variations in the registered "spectrum" depending on the dielectric permittivity and conductivity of the sample. In this way the distinguishing between various media, various substances and their various concentrations is made possible. The following advantages of the proposed principle must be pointed out. Firstly, the measuring procedure is contactless – during the signal registration the sample can be placed in a plastic, or glass container and thus no dilution or sample contamination occurs, moreover the inductor coil can be wrapped around the tubes, pipes, etc. Secondly, the response time of the detector is less than 100 ms, thus the real-time online signal registration is possible, and moreover the dynamic measurements over the flowing media are also possible. Thirdly, the overall experimental layout of the device is extremely simple and inexpensive.

The proposed concept was tested for several tasks to confirm its' potential. The applicability of the device to distinguish between different electrolyte solutions (KCl, NH<sub>4</sub>Cl, KNO<sub>3</sub>, Cu(NO<sub>3</sub>)<sub>2</sub>) was demonstrated. Moreover, it was shown that the detector is able to distinguish between various concentrations of the electrolytes in the concentration range 10<sup>-3</sup> – 10<sup>-1</sup> M. Another experiment revealed that the device is able to detect the differences in the dielectric properties of organic solvents, it was also shown that linear calibration model relating the registered signal and solvent's dipole moment can be constructed. The applicability of the detector to real samples was demonstrated in the experiment with milk and cream samples with various fat contents. The device was shown to yield the signal linearly related to these values. All the measurements were performed in standard 10 ml HDPE Eppendorf vessels without any sample preparation. In addition, the detector was employed in a column chromatography experiment to detect the elution of several halogenide ions.

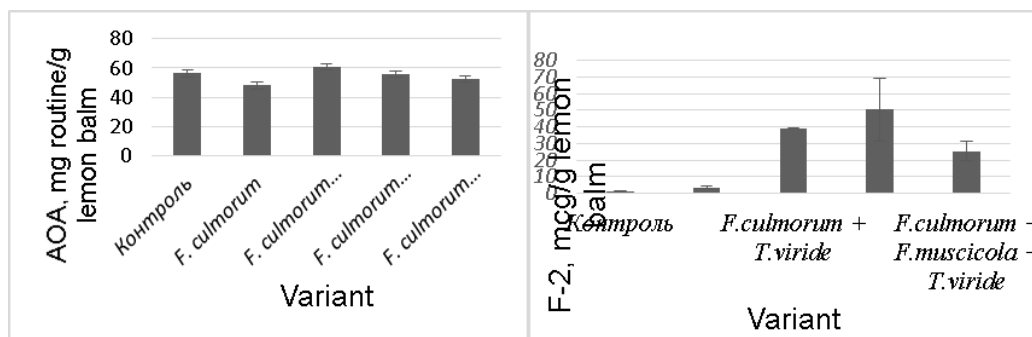
The details on these studies will be provided in the presentation along with the discussion on possible perspectives of the device.

Different factors of surrounding area influence on production of biologically active compounds by medical plants [1]. One of the most significant biotic factors that cause changes in plant's metabolism is soil microbiome. As well known, a contamination by phytopathogenic microorganisms lead to stress in a plant through reactive oxygen species formation [2]. Also, phytopathogens produce toxins, and some of them are harmful for human. At the other hand, there are many of helpful non phytopathogenic microorganisms such as cyanobacteria, that provide nutrition for a plant [3]. In current studding we used widespread phytopathogen *Fusarium culmorum* and their antagonists: cyanobacterium *Fisherella muscicola* and micromycete *Trichoderma veride*, as the soil microbiome. On this substrate we grew the medical plant – *Melissa officinalis*.

The aim of our research was to find out how the phytopathogen *F. culmorum* and their antagonists influence on important characteristic of medical plant – antioxidant activity (AOA) and the toxicity conditioned by *Fusarium's* micotoxins on example of zearalenone (F-2).

*M. officinalis* was growing in the substrate with following microorganisms: a) *F. culmorum* + *F. muscicola* b) *F. culmorum* + *T. veride* c) *F. culmorum* + *F. muscicola* + *T. veride* d) *F. culmorum* e) the control with no microorganisms. The quantity of microorganisms was *F. culmorum* – T =  $(5,00 \pm 0,05) \cdot 10^9$  cells/cm<sup>3</sup>, 1 cm<sup>3</sup> on 60 g of soil, *F. muscicola* – T =  $(3,00 \pm 0,05) \cdot 10^9$  cells/cm<sup>3</sup>, 5 cm<sup>3</sup> on 60 g of soil, *T. veride* – T =  $(5,0 \pm 0,1) \cdot 10^9$  cells/cm<sup>3</sup>, 5 cm<sup>3</sup> on 60 g of soil. The process took two months.

The total AOA was studded by coulometric titration. The method based on the reaction of antioxidants with high reactive electrogenerated halides using coulometer «Экснерт-006» (Russia). Exact quantity of dry lemon balm around 0,1 g was placed in 10 cm<sup>3</sup> of C<sub>2</sub>H<sub>5</sub>OH (ethanol : water – 1:1) and was thermostatically controlled for 2 hours. The possibility of using this method was proved through such validation's characteristics as the linearity and the correctness (using t-criteria of Student) (GPA.1.1.0013.15). The results in mg of routine on 1 g of lemon balm are placed in figure 1 (left).



**Figure 1.** The results of quantitative analysis (n=3, P=0,95). The average square deviation of the analysis results is given as the error limits.

F-2 was extracted from the dry lemon balm with method which described in GOST 28001–88. The detection was carried out by spectrofluorometer Shimadzu RF-5301PC (Japan), because it's known that F-2 toxin has his own fluorescence [4]. The wavelength of excitation was 274 nm, and the wavelength of detection was around 330 nm. For the quantitative analysis we used calibration schedule from state standard sample. The correctness was proved using t-criteria of Student. The results are in figure 1 (right).

The results give us the information that the *F. culmorum* decrease the total AOA of medical plant *M. officinalis*, but the production of F-2 toxin is highly dependent on other microorganisms in soil and in their absence F-2 toxin quantity are in the low level. But at the same time antagonists of the phytopathogen increase the total AOA. This information shows us how the soil microbiome can be use in the cultivation of medicinal plants for the receiving of more qualitative resources for pharmaceutical manufacturing.

#### References

- [1] Yang L., Wen K.S., et al. *Molecules* **2018**, 4, 762.
- [2] Aybeke M. *Microbiol. res.* **2017**, 201, 46–51.
- [3] Rai A.N., Singh A.K., et al. Elsevier Inc. **2019**, 459–476.
- [4] Trineeva O.V. *Drug development & registration.* **2020**, 3. 67–109.

<sup>1</sup>Moscow State University, Moscow, Russia

Student

[Zarochintsev-aa@ya.ru](mailto:Zarochintsev-aa@ya.ru)

Inspired by nature and aiming to overcome the high cost and low stability of enzymes, nanozymes – nanomaterials mimicking enzymatic activity – have emerged as a distinct branch of biomimetics. Nanozymes with peroxidase-like activity are of particular interest as horseradish peroxidase (HRP) is the most widely used enzyme in both biotechnology and medical analysis. Unfortunately, two essential criteria to be eligible for either application, catalytic selectivity and high activity in pH 7.0-7.4, aren't met by an overwhelming majority of known nanozymes. However, Prussian Blue nanoparticles (PBNPs) obtained through catalytic synthesis meet both criteria, which makes them prominent candidates for analyses in biological matrices.

The procedure noted as catalytic synthesis consists in controlled reduction of  $\text{Fe}[\text{Fe}(\text{CN})_6]$ . Using  $\text{H}_2\text{O}_2$  as the reductant, on the one hand, forms pure PBNPs with minimal impurities as oxygen, the product of  $\text{H}_2\text{O}_2$  oxidation, leaves the reaction mixture. This protocol yields PBNPs with record catalytic activity, beating HRP in terms of turnover number by up to 4 orders of magnitude [1]. On the other hand, monomers of conductive polymers are also applicable as reductants. Undergoing oxidative polymerization, they reduce Prussian Green to Prussian Blue, thus forming composite PB/conductive polymer NPs. By using monomers with different functional groups, PBNPs can be functionalized at the stage of synthesis. Moreover, diameter of noted PBNPs can also be controlled by simply varying the concentration of reactants.

Both catalytic and electrocatalytic activity of noted PBNPs are notable. PBNPs possess record catalytic activity with size-dependent catalytic constants, which are comparable and exceeding that of HRP by up to four orders of magnitude. Simple drop-casting of PBNPs colloidal solution followed by annealing at 100 °C results in ready-to-use  $\text{H}_2\text{O}_2$  electrochemical sensor. Sensitivity of noted sensors ( $0.85 \text{ A} \cdot \text{M}^{-1} \cdot \text{cm}^{-2}$ ) is higher than that of PB film based sensors by 30% and allows detecting submicromolar  $\text{H}_2\text{O}_2$  concentrations. Notably, modifying PBNPs with conductive polymers barely decreases their (electro)catalytic activity while significantly improving operational stability. Electrochemical  $\text{H}_2\text{O}_2$  sensors based on PB/p-(3-aminophenylboronic acid) NPs retain 90% of their initial signal twice as long as sensors based on non-functionalized PBNPs [2].

Achieved sensitivity of  $0.85 \text{ A} \cdot \text{M}^{-1} \cdot \text{cm}^{-2}$  can be further increased with carbon black nanoparticles (CBNPs), resulting in record sensitivity of  $1.15 \text{ A} \cdot \text{M}^{-1} \cdot \text{cm}^{-2}$ , almost doubling the sensitivity of PB film based sensors. Both glucose and lactate oxidases were co-immobilized with PBNPs-CBNPs mixture. The aforementioned drop-casting approach results in biosensors advantageous over conventional sensors produced upon layer-by-layer immobilization in terms of one order of magnitude higher sensitivity and three times extended operation time [3].

Azide-modified PBNPs were successfully bioconjugated with alkene-modified oligonucleotide fragments through copper(I)-mediated 1,3-dipolar cycloaddition. Obtained conjugates were used in a prototype of electrochemical DNA sensor. Practical possibility of detection of conjugates' hybridization with immobilized DNA probes was shown, thus allowing development of universal DNA/RNA sensors. The detection limit of oligonucleotides in model systems does not exceed 100 pM.

Amine- and carboxy-modified PBNPs were linked to rabbit and donkey antibodies by means of N,N'-dicyclocarbodiimide for direct electrochemical immunoassay trials. Antibodies forming affine complexes seemingly separate the electrode surface and PBNPs, which dramatically decreases the electrocatalytic current of  $\text{H}_2\text{O}_2$  reduction in noted immunoassay trials. However, this problem was solved by using a redox mediator, catechol. In presence of catechol, at concentrations of conjugates around 100-200 pmol/cm<sup>2</sup> the electrochemical signal is an order of magnitude higher than that of control experiments. This shows the potential of PBNPs as potential catalytic labels in various immunoassays.

### References

- [1] Komkova M.A., Karyakina E.E., Karyakin A.A., *J. Am. Chem. Soc* **2018**, 140, 11302–11307
- [2] Komkova M.A., Zarochintsev A.A., Karyakina E.E., Karyakin A.A., *J. Electroanal. Chem.* **2020**, SI(872), 114048
- [3] Komkova M.A., Andreeva K.D., Zarochintsev A.A., Karyakin A.A. *ChemElectroChem* **2021**, 8, 1117-1122

Acknowledgements. This work was supported by the Russian Science Foundation (project No 21-73-10123).



STUDY OF THE POSSIBILITY OF USING DEEP EUTECTIC SOLVENTS AS A MEDIUM FOR CARRYING OUT A CHEMILUMINESCENT REACTION BASED ON LUMINOL

*Zhdanova M.A., Shishov A.Y.*

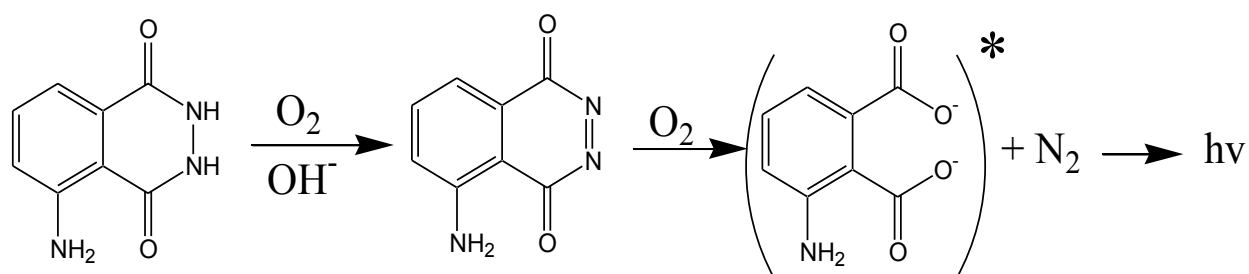
Saint Petersburg State University, Saint Petersburg, Russia

Student

[marina.zhdanova.1998@mail.ru](mailto:marina.zhdanova.1998@mail.ru)

Deep eutectic solvents are increasingly used in various fields of analytical chemistry. They have proven themselves to be effective extractants for the isolation of organic and inorganic analytes from various objects of analysis. The possibility of using eutectic solvents in electrochemical analysis, for the modification and synthesis of various sorbents, and as stationary and mobile phases in chromatography was also demonstrated. However, the possibility of using deep eutectic solvents as a medium for conducting chemiluminescent analytical reactions has not yet been presented in the literature.

Chemiluminescence is one of the most sensitive methods of chemical analysis, but the disadvantage of this method is the significant influence of various chemicals on the processes of chemiluminescence reactions [1-2].



**Figure 1.** Luminol oxidation reaction.

Figure 1 shows the mechanism of the luminol oxidation reaction, which underlies chemiluminescence analysis.

In this work, the possibility of using deep eutectic solvents simultaneously as extractants and as a medium for chemiluminescent reactions is demonstrated for the first time. The main types of eutectic solvents based on alcohols, acids and urea were studied. The reaction of oxidation of luminol with hydrogen peroxide was chosen as the analytical reaction. An illustration of the analytical capabilities of this approach was demonstrated when developing a method for determining hydrogen sulfide in various objects of analysis.

#### References

- [1] Shishov A., Pochivalov A, Nugbienyo L., Andruch V., Bulatov A. *Trends Anal. Chem.* **2020**, 129, 115956
- [2] Sadeghi S., Davami A. *Microchim. Acta.* **2020**, 187, 147

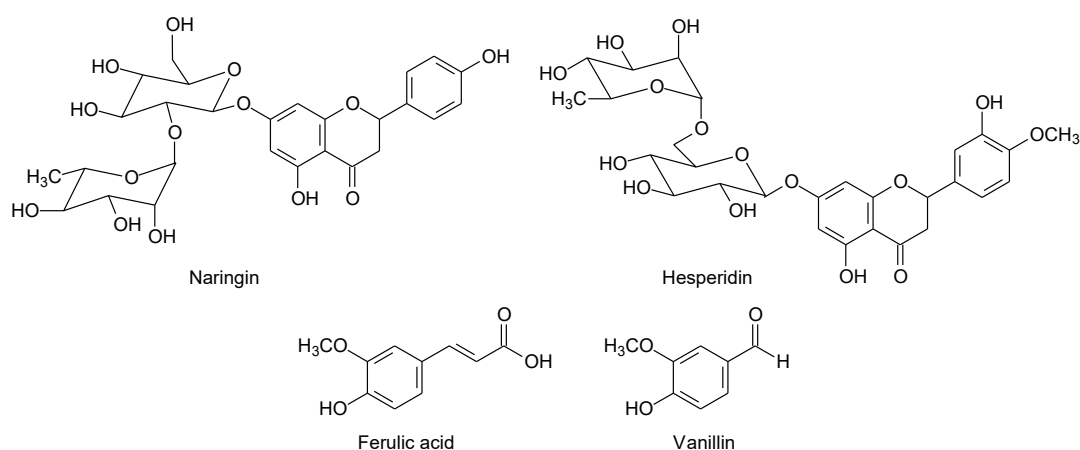
# SIMULTANEOUS VOLTAMMETRIC QUANTIFICATION OF NATURAL PHENOLIC ANTIOXIDANTS USING ELECTRODES MODIFIED WITH ELECTROPOLYMERIZED DYES

*Zhupanova A.S., Ziyatdinova G.K.*

Kazan Federal University, Kazan, Russia  
PhD student  
Zhupanova.Nastya@mail.ru

Simultaneous determination of natural phenolic antioxidants is important problem in analytical chemistry that is traditionally solved using separation methods like chromatography and electrophoresis. Active development of chemically modified electrodes opens new opportunities in this field as far as provide higher selectivity and sensitivity of natural phenolic determination. Among a wide range of electrode surface modifiers, carbon nanotubes and electropolymerized dyes as well as their combination are of practical interest.

Novel electrodes based on the polyaminobenzene sulfonic acid functionalized single-walled carbon nanotubes (f-SWNT) and electropolymerized dyes (aluminon or bromocresol purple) for the simultaneous quantification of natural phenolic antioxidants (flavanones (hesperidin and naringin) as well as ferulic acid and vanillin (Fig. 1)) have been developed.



**Figure 1.** Natural phenolic antioxidants under consideration.

The dyes under consideration form non-conductive polymeric coverage that is confirmed by cyclic voltammetry data. Therefore, f-SWNT layer has been drop-casted on the surface of glassy carbon electrode (GCE) prior to dyes electropolymerization in order to provide sufficient conductivity and high surface area of the electrode. The conditions of potentiodynamic electropolymerization have been optimized on the basis of voltammetric response of target analytes (flavanones for polyaluminon-based electrode and ferulic acid and vanillin in the case of poly(bromocresol purple)-modified electrode). Aluminon electropolymerization have to be performed in basic medium from 100  $\mu\text{M}$  monomer solution by 10-fold potential cycling from 0.1 to 0.8 V at potential scan rate of 100  $\text{mV s}^{-1}$ . In this case, statistically significant increase of the naringin and hesperidin oxidation currents with the peak potential separation of 207 mV has been obtained. Poly(bromocresol purple) layer have to be deposited by 10-fold potential cycling from 0.1 to 1.2 V with the scan rate of 100  $\text{mV s}^{-1}$  from 25  $\mu\text{M}$  monomer in phosphate buffer pH 7.0. The well-resolved oxidation peaks of the ferulic acid and vanillin with potential separation of 170 mV as well as increase of the oxidation currents have been obtained on the poly(bromocresol purple)-modified electrode. The electrodes created have been characterized with SEM and complex of electrochemical methods. The polymeric coverage presented by folded structure with pores and channels that significantly increase the effective surface area in comparison to GCE and f-SWNT/GCE. The EIS data show statistically significant decrease of the charge transfer resistance for the electrodes with polymeric films than that for the GCE confirming increase of the electron transfer rate on the modified electrodes.

The electrodes fabricated have been applied for the simultaneous sensitive determination of natural phenolic antioxidants under conditions of differential pulse voltammetry. The linear dynamic ranges of 0.10-2.5 and 2.5-25  $\mu\text{M}$  have been obtained for the flavanones with the detection limits of 0.020 and 0.029  $\mu\text{M}$  for naringin and hesperidin, respectively. Direct simultaneous quantification of ferulic acid and vanillin is possible in the ranges of 0.1-5.0 and 5.0-25  $\mu\text{M}$  for both analytes with the detection limits of 72 and 64 nM, respectively. The electrodes selectivity in the presence of typical interferences and other natural phenolics has been proved that is important advantage over existing methods. Simultaneous voltammetric quantification of natural phenolic antioxidants in real samples (citrus juices and vanilla extract) has been successfully realized.



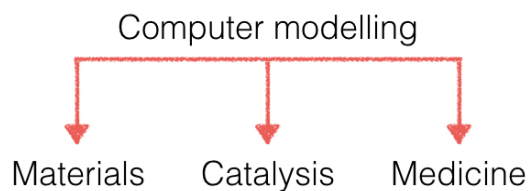
# **COMPUTER MODELLING AND CHEMINFORMATICS**

## COMPUTER MODELLING IN MATERIALS SCIENCE, CATALYSIS, AND MEDICINE

Novikov A.S.<sup>1</sup>

<sup>1</sup>Saint Petersburg State University, Saint Petersburg, Russia  
Chairman of section "Computer modelling and cheminformatics"  
[a.s.novikov@spbu.ru](mailto:a.s.novikov@spbu.ru)

In my short introductory presentation, I will briefly outline the main vectors for using of computer modelling in materials science, catalysis and medicine: what can computational chemistry give for understanding the nature of chemical compounds? The selected aspects of mechanisms of chemical reactions, kinetics and thermodynamics as well as role of metal center, substituents, and noncovalent interactions on properties and reactivity of chemical compounds would be discussed.



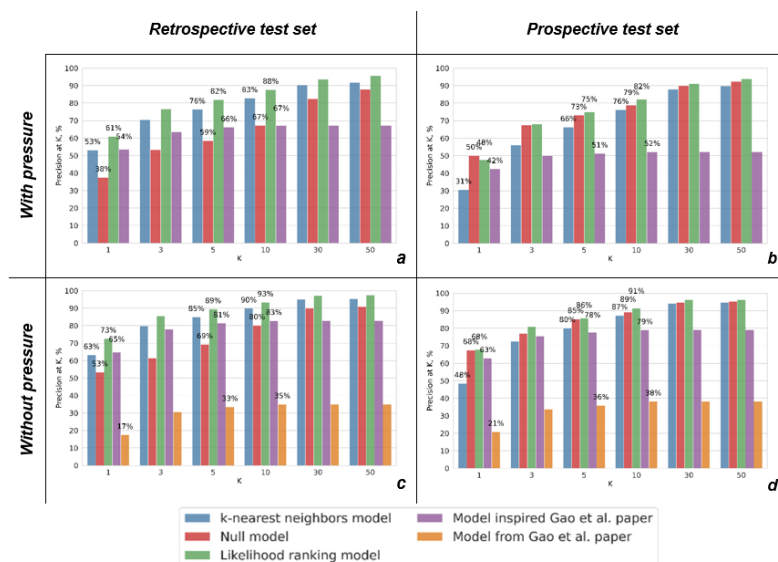
# LIKELIHOOD RANKING APPROACH FOR OPTIMAL CONDITIONS' PREDICTION OF HYDROGENATION REACTIONS

Afonina V.A.<sup>1</sup>, Madzhidov T.I.<sup>1</sup>, Varnek A.<sup>2</sup>

<sup>1</sup>Kazan Federal University, Kazan, Russia  
<sup>2</sup>Strasbourg University, Strasbourg, France  
PhD Student  
[valaafonina@kpfu.ru](mailto:valaafonina@kpfu.ru)

The problem of computer-aided optimal reaction conditions' selection based on the desired reactants and products is attracted special attention in connection with the successes in the field of automatic synthesis planning, recently. The reaction conditions are a rather complex object for quantitative structure-property modeling, starting with the incompleteness of the data presented in the chemical databases (information about the reactions not obtained is not published, the absence of any combination of conditions in relation to the reaction means only that no one tried this option or did not publish such information, but not that the reaction does not go under such conditions), and ending with the possibility of carrying out the reaction with the whole list of conditions and the huge size of the conditions' space in general.

In this paper, we propose the new approach based on artificial neural network – the likelihood ranking approach. The main idea of the proposed approach is based on ranking the combinations of conditions according to their potential applicability to the reaction, determined on the basis of the calculated mean likelihoods of the conditions' combinations, so that the conditions in which the reaction was actually carried out (taken from the literature) are as high as possible in the predicted list of conditions. It was tested on the carefully curated dataset of hydrogenation reactions from Reaxys database. The set of predicted conditions included temperature, pressure, type of additive (acid, base or catalyst poison), catalyst, presented as categorical variables. The roles of chemical compounds were assigned automatically.



**Figure 1.** Cumulative histograms of the percentage of test sets reactions for which at least one of experimental reaction conditions were found within the top of a sorted list of predicted conditions of size K. Note that prediction of pressure is ignored on the histograms c and d

Proposed approach was tested prospectively (on the reactions firstly published in 2017-2019) and retrospectively (on the random reactions moved from the remaining dataset) and it was shown superior performance to null model, which predicts conditions based on their popularity in training data, as well as over nearest-neighbor approach (it ranks possible conditions based on similarity of corresponding reactions to a given one). For hydrogenation reactions, previously proposed approach of Gao et al. [1] (as well as it's reimplemented and retrained on our training set version with some changes) have shown mediocre performance.

## References

[1] Gao H. et al. *ACS Central Science* **2018**, *4*, 1465–1476.

Acknowledgements. This work was supported by the Russian Science Foundation (project No 19-73-10137).

# COMPARATIVE ANALYSIS OF NON-COVALENT INTERACTIONS OF H<sub>2</sub>O/H<sub>2</sub>O<sub>2</sub> IN MULTICOMPONENT ORGANIC CRYSTALS

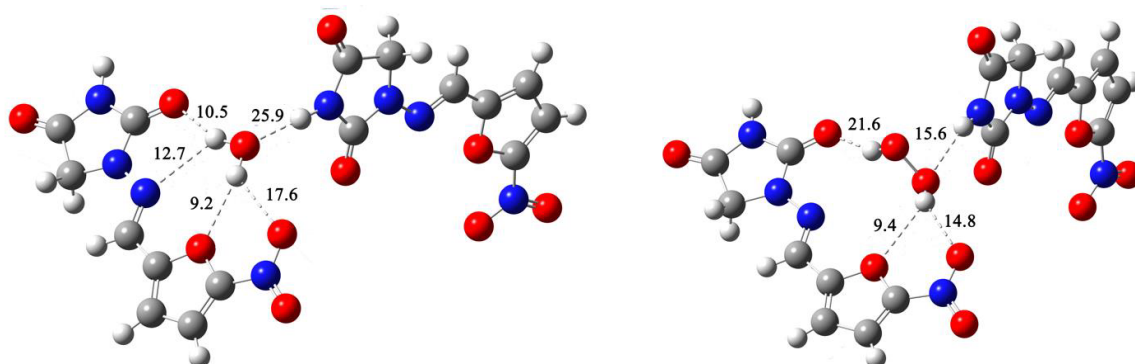
*Alatortsev O.A*<sup>1</sup>, *Artobolevskii S.V*<sup>1</sup>, *Makhrov D.E*<sup>1</sup>

<sup>1</sup>D. Mendeleev University of Chemical Technology of Russia, Moscow, Russian Federation  
[alatorcevoleg3@gmail.com](mailto:alatorcevoleg3@gmail.com)

Calculations and experimental data show that the composition of multicomponent organic crystals is often significantly complicated: in practice, instead of heterodimers, structures containing water or other included molecules are realized. Hydrogen peroxide, being the closest homologue of water, is one of the most important biologically active molecules [1]. Due to its small size and exceptional ability to form hydrogen bonds, it can easily enter into almost any living structure.

Hydrogen bonds pattern in crystallohydrates and peroxosolvates of organic molecules were investigated in [1]. Main attention was paid to the donor (DH bonds) produced by H<sub>2</sub>O/H<sub>2</sub>O<sub>2</sub> molecules. In the presented work we focused on the acceptor hydrogen bonds formed by these molecules. In contrast to peroxosolvates in which acceptor bond is not realized in about 50% crystals, in isostructural crystallohydrates there is almost always one acceptor bond. The analysis of the Cambridge Crystallographic Database and the data that was obtained by us previously [2] show that acceptor bond in cases of crystallohydrates is often the shortest (strong) intermolecular bond.

As an example of the diversity of the networks of H-bonds formed by water/hydrogen peroxide molecules in crystals with organic cofomers, nitrofurantoin (Figure 1) crystallohydrates/peroxosolvates have been studied in detail. These crystals were computed in the PBE-D3/6-31G\*\* approximation using the CRYSTAL17 program [3]. The energy of intermolecular hydrogen bonds has been estimated according to several empirical approaches described in [4].



**Figure 1.** Nitrofurantoin crystallohydrate (left) and peroxosolvate (right). Values of energies were estimated using the [5] approach.

## References

- [1] Surov, A.O.; Vasilev, N.A.; Churakov, A.V.; Parashchuk, O.D.; Artobolevskii, S.V.; Alatortsev, O.A.; Makhrov, D.E.; Vener, M.V. Two Faces of Water in the Formation and Stabilization of Multicomponent Crystals of Zwitterionic Drug-Like Compounds. *Symmetry* **2021**, *13*, 425.
- [2] Chernyshov, I. Y., Vener, M. V., Prikhodchenko, P. V., Medvedev, A. G., Lev, O., and Churakov, A. V. Peroxosolvates: formation criteria, h<sub>2</sub>o<sub>2</sub> hydrogen bonding, and isomorphism with the corresponding hydrates. *Crystal Growth and Design* **2017**, *17*, 214–220.
- [3] Dovesi, R.; Erba, A.; Orlando, R.; Zicovich-Wilson, C.M.; Civalleri, B.; Maschio, L.; Rérat, M.; Casassa, S.; Baima, J.; Salustro, S.; et al. Quantum-mechanical condensed matter simulations with CRYSTAL. *WIREs Comput. Mol. Sci.* **2018**, *8*, e1360.
- [4] Ilogansen, A.V. Direct proportionality of the hydrogen bonding energy and the intensification of the stretching  $\nu$  (XH) vibration in infrared spectra. *Spectrochim. Acta Part A Mol. Biomol. Spectrosc.* **1999**, *55*, 1585–1612.
- [5] Rozenberg, M.; Loewenschuss, A.; Marcus, Y. An empirical correlation between stretching vibration redshift and hydrogen bond length. *PCCP* **2000**, *2*, 2699–2702

Acknowledgements. Authors thank Alexander P. Voronin (G.A. Krestov Institute of Solution Chemistry of RAS) for performing the Bader analysis of the crystal electron density.

# TOPOLOGICAL METHODS FOR ANALYSIS OF POROUS MATERIALS: PORES, BREATHING, CONDUCTIVITY, TRANSFORMATIONS

Alexandrov E.V.<sup>1</sup>

<sup>1</sup>SCTMS, Samara Polytech, Samara, Russia  
PhD, Head of laboratory  
[aleksandrov\\_ev1@mail.ru](mailto:aleksandrov_ev1@mail.ru)

The results of a comprehensive geometrical and topological analysis of 3D coordination networks in 33 790 coordination polymers (including MOFs) were presented [1]. We have found relations between topological descriptors and free space of the networks, and have revealed topological types that promote high porosity of metal–organic frameworks and network flexibility (breathing).

The adsorption properties of MOFs correlate with the structural flexibility. To address this, the full tensor DFT analysis of the second-order elastic constants for 22 either rigid or flexible MOFs assembled from rod secondary building units (rod MOFs) was performed [2]. It was shown that the geometrical–topological features of the coordination framework predetermine the general form of the elastic tensor. Thus the breathing behavior for six rod MOFs of the MIL-53, MIL-118, and CAU-10 families is caused by compliant geometrical–topological patterns and ligand–ligand interactions. The proposed classification of the geometrical–topological patterns into compliant and noncompliant can be used to search for and to design breathing MOFs.

Three new breathing electrically conductive rod MOFs based on a tetrathiafulvalene (TTFTB) linker with La<sup>3+</sup>, 44 rod MOFs of rare earth metals with tetracarboxylate ligands of flat rectangular shape, and 29 other MOFs with the TTFTB ligand were topologically characterized. These MOFs crystallize with different topologies containing distinct  $\pi$ – $\pi$  stacking sequences of the ligand. Notably, their transport properties correlate rationally with the stacking motifs: longer S/S contact distances between adjacent ligands coincide with lower electrical conductivities and higher activation energies. Overall, these rod MOFs demonstrate how tuning the intermolecular interactions control their conductivity.

For crystals of two chain coordination polymers based on polynitrile ligand a transformation to isostructural 3D coordination polymers was studied using X-Ray diffraction and the theoretical topological approach [4]. Applicability of the topological approach to predict possible networks of solid-state reaction products based on the crystal structures of initial compounds was demonstrated.

Topological approach was also extended to analysis of porous hydrogen-bonded organic frameworks (HOFs) [5]. Self-assembly of a rigid and planar ligand unexpectedly gives rise to undulated two-dimensional (2D) honeycomb layers and finally generates three polycatenated HOFs with record complexity. These materials show unique stepwise adsorption behaviors under a certain pressure originating from the movement between mutually interwoven hexagonal networks. Meanwhile, high chemical stability, phase transformation, and preferential adsorption of aromatic compounds were observed in these HOFs. The results would help to understand the self-assembly behaviors of HOFs and shed light on the rational design of HOF materials for practical applications.

## References

- [1] Shevchenko A.P., Alexandrov E.V., Golov A.A., et al. *ChemComm* **2020**, 56, 9616.
- [2] Alexandrov E.V., Goltsev A.V., Eremin R.A., Blatov V.A. *J. Phys. Chem. C* **2019**, 123, 24651.
- [3] Xie L.S., Alexandrov E.V., Skorupskii G., Proserpio D.M., Dincă M. *Chem. Sci.* **2019**, 10, 8558.
- [4] Dmitrienko A.O., Buzin M.I., Setifi Z., et al. *Dalton Transact.* **2020**, 49, 7084.
- [5] Li Y.-L., Alexandrov E.V., Yin Q., et al. *J. Am. Chem. Soc.* **2020**, 142, 7218.

Acknowledgements. This work was supported by Russian Science Foundation (project No 18-73-10116) and Ministry of Education and Science of Russian Federation (project No 0778-2020-0005).

# A FAMILY OF ETHYL *N*-SALICYLIDENEGLYCINATE DYES STABILIZED BY INTRAMOLECULAR HYDROGEN BONDING: PHOTOPHYSICAL PROPERTIES AND COMPUTATIONAL STUDY

Alkhimova L.E.<sup>1</sup>, Babashkina M.G.<sup>2</sup>, Safin D.A.<sup>1</sup>

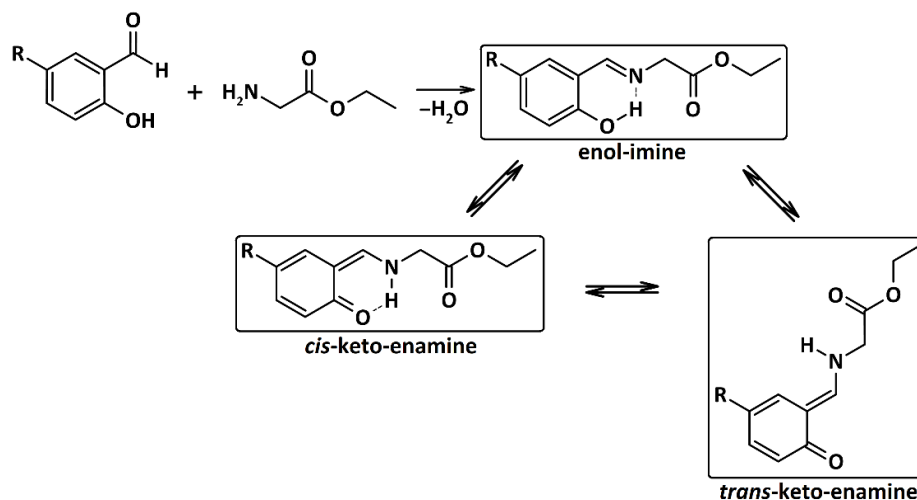
<sup>1</sup>University of Tyumen, Tyumen, Russia

<sup>2</sup>Université Catholique de Louvain, Louvain-la-Neuve, Belgium  
Student

[l.e.alkhim@gmail.com](mailto:l.e.alkhim@gmail.com)

The photophysical properties of a family of ethyl *N*-salicylidene-glycinates, namely ethyl *N*-salicylidene-glycinate (**1**), ethyl *N*-(5-methoxysalicylidene)glycinate (**2**), ethyl *N*-(5-bromosalicylidene)glycinate (**3**), and ethyl *N*-(5-nitrosalicylidene)glycinate (**4**), were studied recently [1–3]. **1–4** correspond to a class of *N*-salicylidene aniline derivatives, which are characterized by enol-imine and keto-enamine tautomerization due to a volatile hydrogen atom that can migrate from the OH group to the imine N-atom. Such an intramolecular proton transfer can influence photophysical properties. With all this in mind, we have probed photophysical properties of **1–4** in different non-polar and (a)protic polar solvents as well as upon gradual addition of NEt<sub>3</sub>, NaOH, and CH<sub>3</sub>SO<sub>3</sub>H [3].

We have also applied the DFT calculations to study the enol-imine–keto-enamine tautomerization. It was established that all the tautomers of **1–4** are characterized by high electron-donating properties [3]. Both the carbonyl and hydroxyl oxygen atoms in **1–4** as well as the oxygen atoms of the NO<sub>2</sub> group in **4** were found to be the most pronounced nucleophilic centres for the enol-imine tautomers. For the keto-enamine forms the electron density is mainly located on the carbonyl oxygen atom attached to the aromatic ring, alongside with both oxygen atoms of the NO<sub>2</sub> group in **4**, while the carbonyl oxygen atom of the carboxyl group becomes less nucleophilic [3]. The electrophilic centres are spread over the CH=N–CH<sub>2</sub> and CH–NH–CH<sub>2</sub> fragments for the enol-imine and keto-enamine tautomers of **1–4**, respectively [3]. The calculated absorption spectra of the fully optimized ground state geometry of all the three tautomers of **1–4** were found in good agreement with experimental spectra [3].



**Figure 1.** Synthesis and tautomeric forms of **1** (R = H), **2** (R = OMe), **3** (R = Br) and **4** (R = NO<sub>2</sub>).

All the tautomeric forms of **1–4** were probed *in silico* as ligands with a series of SARS-CoV-2 proteins. It was established that both the *cis*- and *trans*-keto-enamine tautomers exhibit larger affinity towards the applied SARS-CoV-2 proteins in comparison with the enol-imine tautomers for **1–4**. This finding allows to conclude that the binding energy between the corresponding *N*-salicylidene aniline derivatives and proteins can be tuned through the formation of tautomers by using different solvents as a reaction medium.

## References

- [1] Shapenova D.S., Shiryayev A.A., Bolte M., Kukułka M., Szczepanik D.W., Hooper J., Babashkina M.G., Mahmoudi G., Mitoraj M.P., Safin D.A. *Chem. Eur. J.* **2020**, *26*, 12987–12995.
- [2] Shiryayev A.A., Burkhanova T.M., Mahmoudi G., Babashkina M.G., Safin, D.A. *J. Lumin.* **2020**, *226*, 117454.
- [3] Alkhimova L.E., Babashkina M.G., Safin D.A. *Molecules* **2021**, *26*, 3112.



# KINETIC MODELING OF LIGHT HYDROCARBON ZEOFORMING PROCESS

*Altynov A.A.,<sup>1</sup> Bogdanov I.A.,<sup>1</sup> Kirgina M.V.<sup>1</sup>*

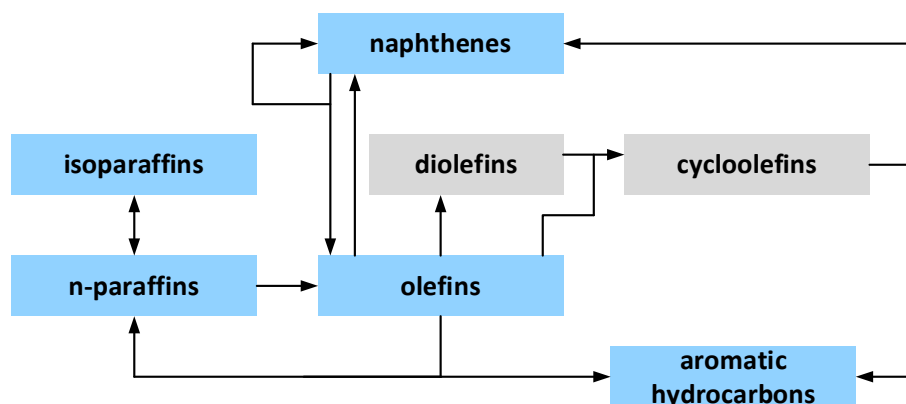
<sup>1</sup>National Research Tomsk Polytechnic University, Tomsk, Russia

PhD-student

[andrey\\_altun@mail.ru](mailto:andrey_altun@mail.ru)

The studies of composition and characteristics of stable gas condensates (SGC), which are commercial gas by-products, and products of their processing on a zeolite catalyst, showed that SGC is a promising feedstock for the gasoline production. It was found that the main components in the composition of various SGC are C<sub>5</sub>-C<sub>7</sub> hydrocarbons [1]. However, the zeoforming process mathematical model creation, based on the data obtained during the processing of SGC is complicated by their multicomponent composition. That's why for creation of zeoforming process mathematical model the pure light hydrocarbons (n-pentane, n-hexane and n-heptane) was processed on a laboratory catalytic unit. The zeolite with ZSM-5 structure used as the catalyst. The test was carried out in the temperature range 648-698 K with a 25 K step, a pressure of 0.25 MPa, and a feedstock flow rate of 2 h<sup>-1</sup>. Individual hydrocarbon composition analysis of the obtained products was carried out by gas chromatography. The resulting individual product composition was aggregated and formalized. Substances with the lowest concentrations are combined into pseudo-components.

The first stage in creating a mathematical model of a chemical technological process is the development of a kinetic description. Based on the process products composition analysis, as well as theoretical representations of the mechanism of transformation occurring at high silica zeolite type ZSM-5 the list of theoretically possible reactions was formed. The list contains chemical reactions occurring during zeoforming of n-pentane, n-hexane and n-heptane, upon which the formalized scheme was drawn up for the transformation of substances on a zeolite catalyst. The scheme presented in Figure 1.



**Figure 1.** Formalized scheme for the light hydrocarbon feedstock transformation on a zeolite catalyst.

The complete list consists of 865 theoretically possible reactions. For each reaction, the thermodynamic parameters were calculated in the Gaussian software package [2].

The analysis showed that out of 865 theoretically possible reactions, 777 reactions are thermodynamically possible. For the kinetic description of hydrocarbon's transformations on the surface of the ZSM-5 type zeolite catalyst, 140 equations of chemical reactions that link n-pentane, n-hexane and n-heptane with intermediate components and reaction products, according to the proposed scheme, were compiled (Figure 1). For each component the differential equation of chemical reaction rate, according to the law of mass action was formed. Based on differential equations, that describe the rates of chemical reactions, an ordinary differential equations system for 50 individual reaction components and pseudo-components was compiled.

Thus, a kinetic mathematical model of light hydrocarbon feedstock zeoforming was developed, which allows predicting the composition of the resulting product.

## References

- [1] Kirgina M., Belinskaya N., Altynov A., Bogdanov I., Temirbolat A. *J. Nat. Gas Sci. Eng.* **2020**, 84, 103605.
- [2] Ochterski J.W. *Thermochemistry in Gaussian*. Gaussian, Inc. – 2000. – 19 p.

Acknowledgements. This work was supported by Grant of the President of the Russian Federation No. MK-351.2020.3.

# PARAMETRIZATION OF THE AMBER FORCE FIELD FOR THE DESCRIPTION OF CHITOSAN-RNA COMPLEXES

*Avdoshin A.A.<sup>1</sup>, Naumov V.S.<sup>1</sup> Koeppen S.<sup>2</sup> Colombi L.C.<sup>2</sup> Ignatov S.K.*

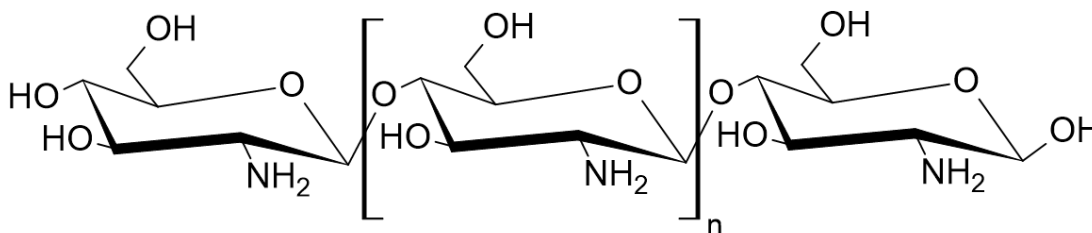
<sup>1</sup>Lobachevsky State University, Nizhny Novgorod, Russia

<sup>2</sup>University of Bremen, Bremen, Germany

Student

[avdoshinaa95@gmail.com](mailto:avdoshinaa95@gmail.com)

RNA is a polymer molecule involved in the coding, decoding, regulation and expression of genes. MicroRNA is involved in transcriptional and post-transcriptional regulation of genes by RNA interference. The missing regulation can affect oncogenes or tumour suppressor genes mediating cell cycle regulation, apoptosis, senescence, metabolism, angiogenesis and metastasis. MiRNA shows a high influence regarding gene expression and protein formation. RNA is used for the development of novel high-technological medicines including anti-age and anti-cancer drugs. To enter a cell, microRNA must overcome biological barriers in the form of aggressive biological media, such as gastric juice, a physical barrier in the form of mucus in the intestine, and tight junctions of the intestinal walls. To increase the bioavailability of RNA, protection in the form of targeted drug delivery systems is required. Chitosan is one of the most potential materials for such carriers due to many unique physicochemical and biological properties, among which one can distinguish its biocompatibility, low cost, and mucoadhesion (the latest property is especially useful because it leads to the temporary opening of dense compounds in the membrane of the cells of the mucous membrane). Due to the presence of an amino group, chitosan can be easily modified to give it the required properties, for example, solubility or a certain biological activity. The amino group can undergo acylation, reactions with aldehydes and ketones, alkylation, grafting of the polymer of the side groups, chelation of metals, the formation of quaternary ammonium salts, the formation of hydrogen bonds with polar atoms and other reactions. Thus, it is possible to obtain modified chitosan that have a set of required properties (antibacterial, antifungal, antiviral), combined with hypoallergenicity, biological compatibility and biodegradability.<sup>3</sup> In addition to the amino group, chitosan has two hydroxyl groups at the C2 and C6 atoms glucopyranose. Owing to these groups, a number of reactions become possible for chitosan, as well as for cellulose: etherification, graft copolymerization, as well as O-acylation, formation of hydrogen bonds with polar atoms and other reactions.



**Figure 1.** Structure of chitosan.

The experimental study of chitosan is complicated by the strong dependence of its properties on the degree of acetylation and the length of polymer chains. Therefore, molecular dynamics (MD) can act as a tool for studying such materials. Currently, there is no unified force field (FF) for calculating the structure and properties of chitosan and microRNA. In order to develop such a FF, in this work, we calculated the geometries and charges of chitosan residues using quantum chemical methods (B3PW91 / 6-311G (d, p) and HF / 6-31G \*). The quality of the force field was assessed based on the analysis of conformational of exocyclic groups, pyranose ring and glycoside bonds. The FF constants of their bonds and angular parameters were estimated using modern a variant of the hamiltonian replica exchange method. The obtained values are verified by comparison with the results of the experiment and calculations in the joint venture GROMOS 56ACARBO\_CHT. The found molecular parameters were used to modify FF AMBER, which was supplemented with residues of unmodified, protonated, and acylated chitosan. A new model of chitosan was used to assess the geometry and thermos - dynamics properties of RNA - chitosan complexes.

Acknowledgements. This work was supported by *East Partnership programs of Bremen University u PΦΦИ (проект № 20-02-00712)*.

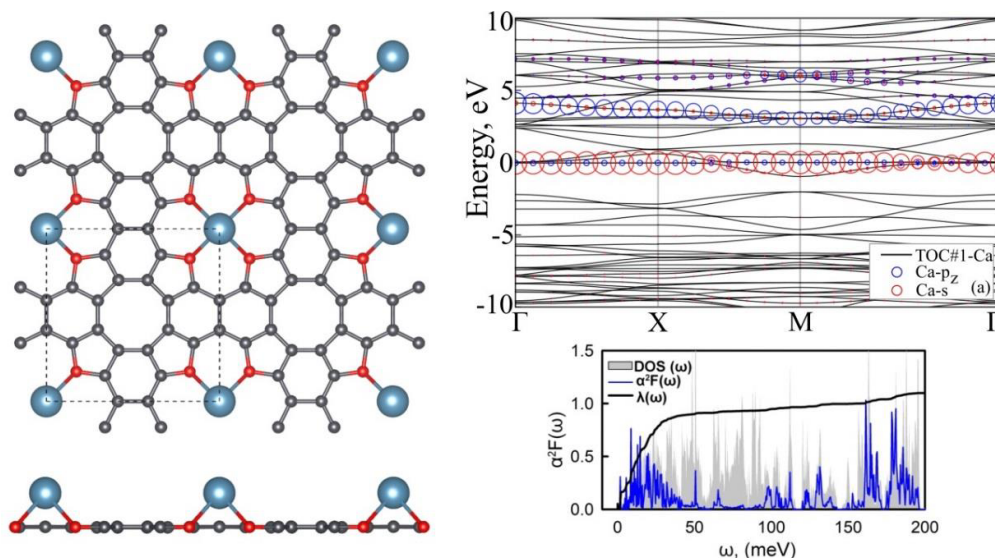
<sup>1</sup>Siberian Federal University, Krasnoyarsk, Russia<sup>2</sup>Kirensky Institute of Physics, Krasnoyarsk, Russia<sup>3</sup>Uppsala University, Uppsala, Sweden<sup>4</sup>Bohdan Khmelnytsky National University, Cherkasy, Ukraine<sup>5</sup>Linköping University, Norrköping, Sweden<sup>6</sup>National Research Tomsk Polytechnic University, Tomsk, Russia<sup>7</sup>University of Helsinki, Helsinki, Finland<sup>8</sup>Henan University, Kaifeng, P.R. China

Junior researcher

[lyuda.illuzia@gmail.com](mailto:lyuda.illuzia@gmail.com)

Covalent organic frameworks (COFs) consisting of heterocyclic molecules become to attract a lot of attention due to the possibility of flexible variation of their properties. The properties depend on the selected moiety, on the type of fusing between moieties and on the size of the obtained nanomaterials. Typical examples of such COFs are tetraoxa[8]circulene (TOC) based nanosheets, which are planar two-dimensional (2D) porous sheets with the space group symmetry  $P4/mmm$ . The unique structure of the polymers allows metal atoms to be embedded regularly and separately, providing promising new features and expanding the applications of such materials.

In this work, we theoretically study a series of new organometallic porous sheets based on two-dimensional tetraoxa[8]circulene polymers doped with alkali or alkaline-earth metals. The results show that the localization of metal atoms depends on the pore size: polymer with larger pores promotes the localization of metal atoms in its plane. All organometallic structures are energetically stable. The interaction with s-metal atoms changes the electronic structure of TOC sheets from semiconducting to conducting due to n-doping. Ca-doped TOC demonstrates a high density of states in the vicinity of the Fermi level and induced superconductivity. Using the ab initio Eliashberg formalism we find that TOC-Ca polymer are phonon-mediated superconductors with a critical temperature of 14.5 K. This value is within the range of typical carbon-based superconducting materials. Moreover, calculations reveal a unique open-shell singlet ground state in the TOC-Ca complex with the Ca atom and TOC being doublets. Therefore, combining proved superconductivity and the long spin lifetime in doublet Ca such materials could be an ideal platform for realization of quantum bits [1].



**Figure 1.** Structure and properties of organometallic polymers based on tetraoxa[8]circulene and calcium atoms. DOS,  $\alpha^2F(\omega)$ ,  $\lambda(\omega)$  and  $\omega$  are phonon density of states, Eliashberg spectral function, electron-phonon coupling and frequency, respectively.

### References

[1] Begunovich L.V., Kuklin A.V., Baryshnikov G.V., Valiev R.R., Ågren H. *Nanoscale* **2021**, 13, 4799.

Acknowledgements. This work was supported by the Russian Science Foundation (project No 19-73-10015).

# METADYNAMICS IN STUDYING THE BIGENELLI REACTION MECHANISM WITH THE PARTICIPATION OF CHIRAL INDUCTORS

*Borodina O.S.*<sup>1</sup>, *Makarov G.I.*<sup>1</sup>, *Bartashevich E.V.*<sup>1</sup>, *Ovchinnikova I.G.*<sup>2</sup>, *Fedorova O.V.*<sup>2</sup>, *Titova Y.A.*<sup>2</sup>

<sup>1</sup>South Ural State University, Chelyabinsk, Russia;

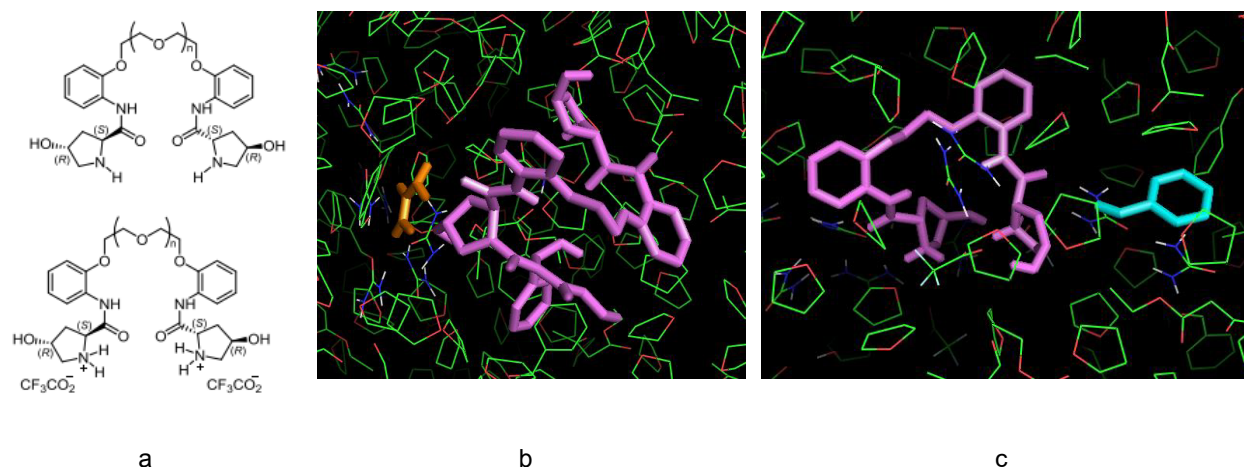
<sup>2</sup>Postovsky Institute of Organic Synthesis, Ural Branch of the Russian Academy of Sciences, Yekaterinburg, Russia;

<sup>3</sup>Ural Federal University, Yekaterinburg, Russia

Student

[borodinaos@susu.ru](mailto:borodinaos@susu.ru)

The diffusion stages of two possible sequences of the Bigenelli reaction with the participation of hydroxyproline-containing podands as chiral inductors, at which the stereocenter of the dihydropyrimidinone product is formed, have been modeled [1].



**Figure 1.** Studied podands,  $n = 0.2$  (a) and modeling of the (b) approach of urea (orange color) to the formed podand intermediate with covalently bound acetoacetic ether and benzaldehyde (purple color); (c) benzaldehyde (blue) to podand (purple). All reaction components and THF as a solvent are present in the simulated system.

The method of metadynamics was used to study whether the diffusion stage of the reaction, at which the stereocenter is formed, can be stereodifferentiating for the entire sequence of Bigenelli reaction, that is, whether the approach of reagents is carried out predominantly from the *Re* or *Si* side due to the conformational features of chiral inductors, [2]. In this case, the conformational state of the podands varied depending on the degree of protonation and the length of the oxyethylene chain, corresponding to those found earlier [3,4]. It was found that in the course of metadynamics, the obtained conformations of the podands change a bit.

Thus, for each podand in each proposed sequence of condensation reaction, the ratios *R* : *S* of the emerging products were determined according to the energy minimums of the systems under consideration, obtained in the course of metadynamics, which can be used to clarify the sequence of stages and the reaction mechanism with the participation of the chiral inductors.

## References

- [1] Fedorova, O.V., Titova, Y.A., Ovchinnikova, I.G., Rusinov, G.L., Charushin, V.N. *Mendeleev Commun.* **2018**, 28, 357.
- [2] Laio A., Gervasio F.L. *Rep. Prog. Phys.* **2008**, 71, 126601.
- [3] Borodina O.S., et al. *Chem. Heterocycl. Compd.* **2019**, 55, 755–761.
- [4] Bartashevich E.V, et al. *Actual problems of organic chemistry and biotechnology*, **2020**, 311-313.

**Acknowledgements.** This work was supported by the Ministry of Science and Higher Education of the Russian Federation, FENU-2020-0019.

# THE STABILIZATION OF ONLY HYDROGEN-SUBSTITUTED 13/14/15 GROUP ELEMENT CHAINS BY LEWIS ACIDS

*Chernysheva A.M.,<sup>1</sup> Timoshkin A.Y.<sup>1</sup>*

<sup>1</sup>Saint Petersburg State University, Saint Petersburg, Russia  
Postgraduate  
[st040602@student.spbu.ru](mailto:st040602@student.spbu.ru)

The parent (bearing only hydrogen substituents) compounds of *p*-elements, representing isoelectronic homologues of alkanes and featuring the combination of elements of group 13/14/15 in one compound, are of high interest due to their potential use as single-source precursors for ternary materials, which can be used in small band gap optical devices [1]. Such parent compounds can also find application in construction of new inorganic polymers, which are highly desirable [2], as they represent the alternatives to the established organic-based polymers. So far, several Lewis acid and/or Lewis base stabilized parent compounds, containing binary combinations of group 13/15 and 14/15 elements, were synthesized [3]. In order to expand the element chain and obtain ternary parent group 13/14/15 element compounds, unknown up to now, the concept of donor-acceptor stabilization can be used.

In this report the results of computational study (B3LYP-D3/def2-TZVP level of theory) of complexes of  $\text{PH}_2\text{BH}_2\text{E}'\text{H}_2$ ,  $\text{PH}_2\text{E}'\text{H}_2\text{BH}_2$  and  $\text{E}'\text{H}_2\text{PH}_2\text{BH}_2$  ( $\text{E}' = \text{C, Si, Ge}$ ) with Lewis acids are presented. The donor-acceptor complexes in the most cases are not the stable ones: upon geometry optimization they convert to cyclic structures or substituent migration occurs. In case of  $\text{LA} = \text{EX}_3$  ( $\text{E} = \text{B, Al, Ga}$ ;  $\text{X} = \text{F, Cl, Br, I}$ ), there is a strong tendency of one of the halogens to occupy bridging position or to migrate to the acceptor atom of the chain. Pentafluorophenyl-substituents of  $\text{LA} = \text{E}(\text{C}_6\text{F}_5)_3$  ( $\text{E} = \text{B, Al, Ga}$ ) in some cases reveal the same reactivity, becoming bridging or migrated. For  $\text{LA} = \text{M}(\text{CO})_5$  ( $\text{M} = \text{Cr, Mo, W}$ ) and  $\text{Fe}(\text{CO})_4$ , there are additional interactions between acceptor atom of the chain and carbonyl groups or the transition metal with formation of six- and four-membered cycles, respectively. In the cases of only donor-acceptor complex formation (without any other reactivity), the stability of complexes was evaluated by comparison of the equilibrium constants of this process and dimerization of free 13/14/15 chains. It is established that the stabilization by Lewis acid is possible only for  $\text{PH}_2\text{CH}_2\text{BH}_2$ . As a result, we propose complexes of  $\text{PH}_2\text{CH}_2\text{BH}_2$  with  $\text{GaF}_3$ ,  $\text{Cr}(\text{CO})_5$ ,  $\text{Mo}(\text{CO})_5$ ,  $\text{W}(\text{CO})_5$  and  $\text{Fe}(\text{CO})_4$  for further experimental investigation. For other chains additional stabilization by Lewis base is required.

## References

- [1] R. Jia, T. Zhu, V. Bulovic, E. A. Fitzgerald, *J. Appl. Phys.* **2018**, *123*, 175101; b) T. Watkins, A. V. G. Chizmeshya, L. Jiang, D. J. Smith, R. T. Beeler, G. Grzybowski, C. D. Poweleit, J. Menendez, J. Kouvetakis, *J. Am. Chem. Soc.* **2011**, *133*, 16212–16218; c) A. G. Norman, J. M. Olson, J. F. Geisz, H. R. Moutinho, A. Mason, M. M. Al-Jassim, S. M. Vernon, *Appl. Phys. Lett.* **1999**, *74*, 1382.
- [2] I. Manners, *Angew. Chem. Int. Ed. Engl.* **1996**, *35*, 1602–1621.
- [3] a) U. Vogel, A. Y. Timoshkin, K.-C. Schwan, M. Bodensteiner, M. Scheer, *J. Organomet. Chem.* **2006**, *691*, 4556–4564; b) U. Vogel, P. Hoemensch, K.-C. Schwan, A. Y. Timoshkin, M. Scheer, *Chem. Eur. J.* **2003**, *9*, 515–519; c) K.-C. Schwan, A. Y. Timoshkin, M. Zabel, M. Scheer, *Chem. Eur. J.* **2006**, *12*, 4900–4908; d) C. Marquardt, A. Adolf, A. Stauber, M. Bodensteiner, A. V. Virovets, A. Y. Timoshkin, M. Scheer, *Chem. Eur. J.* **2013**, *19*, 11887–11891; e) C. Marquardt, O. Hegen, A. Vogel, A. Stauber, M. Bodensteiner, A. Y. Timoshkin, M. Scheer, *Chem. Eur. J.* **2018**, *24*, 360–363; f) C. Marquardt, O. Hegen, M. Hautmann, G. Balázs, M. Bodensteiner, A. V. Virovets, A. Y. Timoshkin, M. Scheer, *Angew. Chem. Int. Ed.* **2015**, *127*, 13315–13318; g) U. Vogel, A. Y. Timoshkin, M. Scheer, *Angew. Chem. Int. Ed.* **2001**, *40*, 4409–4412. h) M.A.K. Weinhart, A.S. Lisovenko, A.Y. Timoshkin, M. Scheer, *Angew. Chem. Int. Ed.* **2019**, *59*, 5541–5545.

Acknowledgements. This work was supported by the joint grant of Russian Science Foundation and Deutsche Forschungsgemeinschaft (RSF project No 21-43-04404). The use of the equipment of the Resource Center "Computer Center SPbU" is gratefully acknowledged.

COMPUTATIONAL STUDY OF THE PROPERTIES OF NOVEL TRIMETHYLACETATE 1D-POLYMERS  
WITH Dy<sup>III</sup>Cd<sup>II</sup><sub>2</sub> AND Yb<sup>III</sup>Cd<sup>II</sup><sub>2</sub> CORES

*Dmitriev A.A.*<sup>1,2</sup>, *Gritsan N.P.*<sup>1,2</sup>

<sup>1</sup>Novosibirsk State University, Novosibirsk, Russia

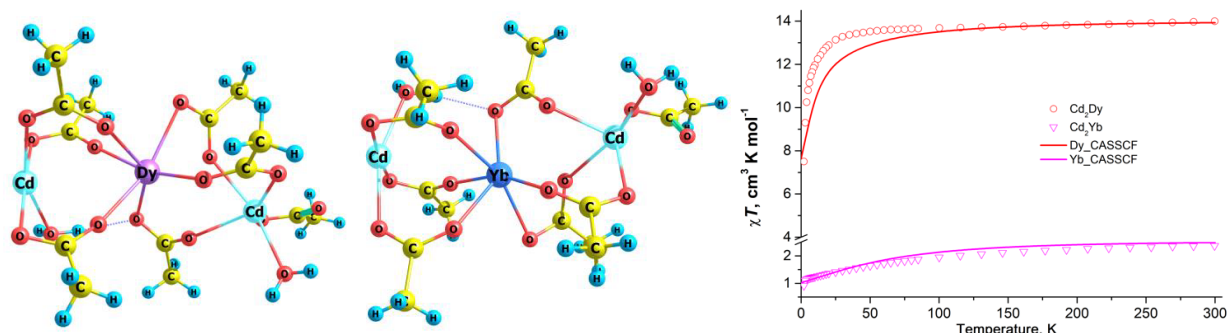
<sup>2</sup>Voevodsky Institute of Chemical Kinetics and Combustion, Novosibirsk, Russia

Young scientist

[dmitralexe@gmail.com](mailto:dmitralexe@gmail.com)

The development of new coordination compounds with two or more physical properties that are promising for practical application are urgent problem of modern coordination chemistry and physical chemistry. Application of elements with Ln<sup>III</sup> ions in such compounds is justified by the unique properties of such ions, i.e. their ability to exhibit slow magnetic relaxation (Single Molecule Magnetism, SMM, or Single Ion Magnetism, SIM) [1] along with luminescence [2]. The influence of Ln<sup>III</sup> surroundings on magnetic relaxation rate due to exchange coupling between Ln<sup>III</sup> ions and, mostly, transitional metal ions via the mechanism of quantum tunneling of magnetization (QTM) is one of the intensively studied problems [3,4]. The most interesting effects were found for magnetically diluted Ln complexes with slow magnetic relaxation [5,6,7]. Additionally, long-range magnetic ordering was found in the Ln<sup>III</sup> coordination polymers [8].

This work presents the computational study of the properties of novel trimethylacetate 1D-polymers with Dy<sup>III</sup>Cd<sup>II</sup><sub>2</sub> and Yb<sup>III</sup>Cd<sup>II</sup><sub>2</sub> cores. High-level *ab initio* SA-CASSCF/SO-RASSI/SINGLE-ANISO calculations of electronic structures and magnetic properties of these compounds were performed. The computations were done for smaller structural fragments of individual spin centers (Figure 1). Scalar relativistic effects were taken into account using the DKH2 Hamiltonian. Complexes exhibit the properties of field induced SMMs. The calculated temperature dependence of magnetic susceptibility coincide well with experimental data (Figure 1). Based on the analysis of the relaxation of magnetization and high-level *ab initio* calculations, the predominant relaxations mechanisms were proposed for DyCd<sub>2</sub> (the sum of Raman and QTM mechanisms) and YbCd<sub>2</sub> (the sum of the direct and Raman mechanisms) complexes.



**Figure 1.** (left and center) The structures of DyCd<sub>2</sub> and YbCd<sub>2</sub> core units used in calculations; (right) The experimental and calculated temperature dependence of magnetic susceptibilities of two compounds.

### References

- [1] Dey A., Kalita P., Chandrasekhar V. *ACS Omega* **2018**, 3(8), 9462–9475.
- [2] Hasegawa Y., Kitagawa Y., Nakanishi T. *NPG Asia Materials* **2018**, 10, 52–70.
- [3] Uekia S., Ishida T., Nogami T., Choi K.Y., Nojiri H. *Chem. Phys. Lett.* **2007**, 440(4-6), 263-267.
- [4] Vignesh K.R., Langley S.K., Murray K.S., Rajaraman G. *Chem.-Eur. J.* **2017**, 23(7), 1654-1666.
- [5] Titos-Padilla S., Ruiz J., Herrera J.M., Brechin E.K., Wersndorfer W., Lloret F., Colacio E. *Inorg.Chem.* **2013**, 52(16), 9620-9626.
- [6] Ruiz-Muelle A.B., García-García A., García-Valdivia A.A., Oyarzabal I., Cepeda J., Seco J.M., Colacio E., Rodríguez-Diéguez A., Fernández I. *Dalton Trans.* **2018**, 47, 12783-12794.
- [7] Lucaccini E., Briganti M., Perfetti M., Vendier L., Costes J.P., Totti F., Sessoli R., Sorace L. *Chem.-Eur. J.* **2016**, 22(16), 5552-5562.
- [8] Bartolomé E., Bartolomé J., Melnic S., Prodius D., Shova S., Arauzo A., Luzón J., Badía-Romano L., Luisb F., Turta C. *Dalton Trans.* **2014**, 43, 10999-11013.

## PREDICTION OF SYNTHESIS PATH OF CHEMICAL COMPOUND AND ITS ANALOGUES

*Fatykhova A.A.*<sup>1</sup>, *Nugmanov R.I.*<sup>1</sup>, *Mukhametgaleev R.N.*<sup>1</sup>, *Madzhidov T.I.*<sup>1</sup>, *Varnek A.*<sup>2</sup>

<sup>1</sup>Kazan Federal University, Kazan, Russia

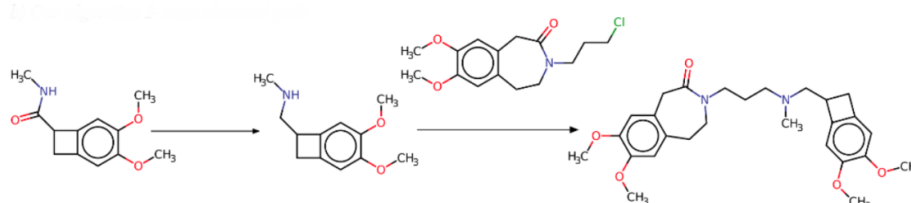
<sup>2</sup>Strasbourg University, Strasbourg, France

PhD student

[adafatyhova@kpfu.ru](mailto:adafatyhova@kpfu.ru)

Currently, the planning of the chemical synthesis of any compound, in particular, medicinal compounds, is an extremely important task. Modern methods of drug development, such as virtual screening, docking, de novo design, allow the generation of many molecules with the necessary biological activity and other properties. One of the problems is that some of the promising molecules cannot move to the next stage of development due to the problem of their synthesis. In this work, we present an approach to planning forward chemical synthesis (from reagents to products) based on the Monte Carlo tree search method. In contrast to the traditional retrosynthetic approach, the forward synthesis method makes it possible to predict the path of synthesis not only of the target molecule, but also of molecules similar to the target one. This is due to the fact that gradually approaching the target molecule, at each stage, the algorithm predicts many compounds that could potentially have similar properties.

The developed tool consists of several main blocks: a database of molecules and reaction rules, modules for virtual reactions generation, and heuristic algorithms for fast search based on similarity metrics. The developed approach uses commercially available chemical compounds as initial reagents and rules of reaction transformations to generate new products. Generation of reactions proceed using the Virtual Reactor [1], which allows the generation of chemically correct structures. Monte Carlo tree search methods allow you to effectively navigate the vast space of chemical compounds, finding the best solutions in the optimal time.



**Figure 1.** Predicted synthesis path for bevantolol by developed algorithm.

Developed approach was validated based on reference pathways of drug molecules, extracted from USPTO database. One predicted path presented on Figure 1.

### References

[1] Nugmanov, R. et al. CGRtools: Python Library for Molecule, Reaction, and Condensed Graph of Reaction Processing. *J. Chem. Inf. Model.* **2019** 59 (6), 2516-2521. doi: 10.1021/acs.jcim.9b00102.

Acknowledgements. This work was supported by the Russian Science Foundation (19-73-10137) (Код ГРНТИ 31.01.77)

COMPARATIVE ASSESSMENT OF THE RESULTS OF NICOTINE REDOCKING WITH ACETYLCHOLINE-BINDING PROTEIN USING AUTODOCK VINA AND IDOCK

*Goloso R.D.<sup>1</sup>, Ivanov I.M.<sup>1</sup>, Orlova A.B.<sup>1</sup>*

<sup>1</sup>State Research Testing Institute of Military Medicine of the Ministry of Defense of the Russian Federation, St. Petersburg, Russia

Student

[rom.goloso@yandex.ru](mailto:rom.goloso@yandex.ru)

Today virtual screening together with chemoinformatics and molecular docking methods is widely used in early stages of drug design. One of the approaches is a structural search based on known physiological targets, which are a complex of a reference ligand with a receptor, obtained by X-ray structural analysis or NMR. The use of such complexes allows one to get information about localization of the binding site on the receptor, as well as about the set of amino acid residues of the macromolecule where the interaction takes place, as well as about chemical nature of these interactions. The use of a macromolecule for flexible docking, which ligand binding area is pre-organized to the reference ligand, allows a directed structural search among libraries of various compounds.

A certain methodological problem is a choice of the region of interaction on the receptor, namely their models containing several recurring binding pockets. For example, a complex of acetylcholine-binding protein (AChBP) with nicotine (PDB ID 1UW6) obtained by X-ray structural analysis contains 10 physiologically identical nicotine binding sites. Meanwhile, the analysis of this complex by means of PLIP 2.2.0 software shows the difference between the "positions" of the reference ligand in them in terms of the set of interacting amino acids and types of chemical bonds with them.

The aim of the study was to compare the results of nicotine redocking at 10 binding sites of the macromolecule (PDB ID 1UW6) in flexible docking mode using Autodock Vina and iDOCK programs. As a criterion for the integral assessment of the degree of similarity between the predicted posture of the ligand and the posture in the original complex the PScore indicator was used. In its calculation the coincidence of amino acid residues of the macromolecule (and the types of interactions with them) where the ligand interacts in the native and predicted posture are taken into account. A PScore value of 100% corresponds to a complete match. The results of 10 repetitions of docking are presented in Table 1.

**Table 1.**

Indicator	PScore values (%) for binding sites									
	1	2	3	4	5	6	7	8	9	10
Vina results										
Average	70,75	46,25	10,56	82,14	64,14	59,16	72,17	39,35	83,36	41,78
The best	84,6	87,5	72,2	85,7	83,3	83,3	78,6	86,7	91,7	64,7
iDOCK results										
Average	44,62	37,15	22,78	61,41	39,18	30,84	47,14	40,02	58,33	43,54
The best	92,3	71,4	61,1	85,7	83,3	83,3	78,6	86,7	91,7	82,4

It was found that following 10 repetitions of docking both programs were able to predict the position of the ligand closely resembling the initial one. The maximum PScore score was 64.2 - 91.2% for Vina and 61.1 - 92.3% for iDOCK. At the same time, the topology of some binding sites, in particular № 2, 3, 5, 6, 8, was such that the average results of assessing the similarity of native and predicted postures were underestimated. The minimum figures were 10.5 - 64.4% for Vina, 22.7 - 40.0% for iDOCK. However, taking into account the relatively high value of the maximum PScore for these sites, it can be concluded that, with a sufficient number of repetitions, both programs are able to predict a ligand position close to the native one, even for sites with difficult topology.

Thus, for macromolecules containing several repeating binding sites, it is advisable to carry out a preliminary assessment of these sites to select the optimal **search space** for docking in order to reduce the cost of computing power for re-running.



# BATTERY MATERIALS DATABASE: THE RESULTS OF A STEPWISE THEORETICAL SEARCH FOR NEW SOLID ION CONDUCTORS

*Kabanov A.A.*<sup>1,2,3</sup>, *Morkhova E.A.*<sup>1,2,4</sup>, *Kabanova N.A.*<sup>1</sup>, *Leisegang T.*<sup>1,5</sup>, *Blatov V.A.*<sup>1,4</sup>

<sup>1</sup>Samara Center for Theoretical Materials Science, Samara State Technical University, Samara, Russia

<sup>2</sup>Institute of Solid State Chemistry and Mechanochemistry SB RAS, Novosibirsk, Russia

<sup>3</sup>P. N. Lebedev Physical Institute of the Russian Academy of Sciences, Samara, Russia

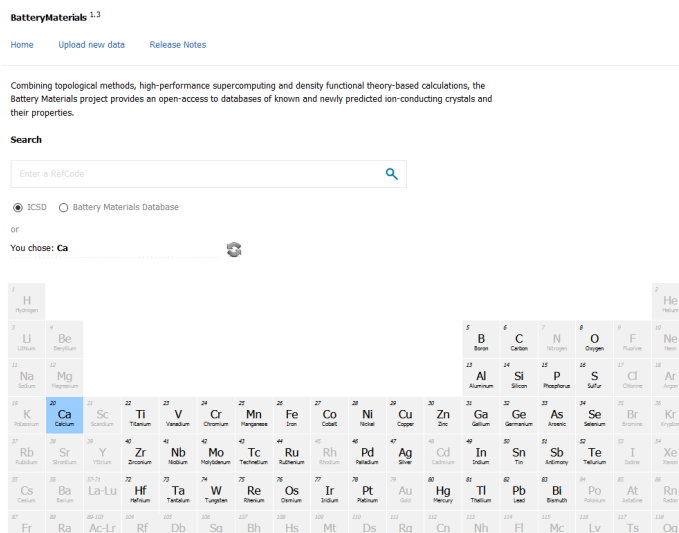
<sup>4</sup>Samara Center for Theoretical Materials Science, Samara University, Samara, Russia

<sup>5</sup>Institute of Experimental Physics, Energy Materials, TU Bergakademie Freiberg, Freiberg, Germany  
[artkabanov@mail.ru](mailto:artkabanov@mail.ru)

Post lithium-ion batteries are hot topic in the field of electrochemical energy storage systems. Such batteries are promising counterparts for expensive lithium-ion batteries (LIBs). Many different variants are proposed, from sodium-ion batteries which are already commercialized [1], till exotic aluminum-ion batteries [2,3]. Nevertheless, any new battery demands new materials. The theoretical search for new crystalline materials with ion conductivity is the goal of this study.

Here we apply a stepwise theoretical screening procedure, which consists of geometrical-topological analysis of free space in solids, bond valence site energy calculations of migration energies, simulation of ionic conductivity by using the kinetic Monte Carlo algorithm and quantum-chemical simulation of ion transport within the Density Functional Theory. We have analysed the Inorganic Crystal Structure Database (ICSD) and selected all ternary and quaternary Na<sup>+</sup>, K<sup>+</sup>, Ag<sup>+</sup>, Mg<sup>2+</sup>, Ca<sup>2+</sup>, Sr<sup>2+</sup>, Zn<sup>2+</sup> and Al<sup>3+</sup> oxides and chalcogenides which theoretically possess ionic conductivity [4,5].

All results were uploaded to the <https://batterymaterials.info> web site as a searchable database (Figure 1). The *BatteryMaterials* database also contains the experimental data gathered from the literature (articles, books, patents etc.). The following main parameters are specified in the database: type of the working ion, dimensionality of migration map, theoretical and experimental (if available) ion migration energy, theoretical and experimental (if available) capacity, conductivity etc. The structural .cif file can be downloaded for each entry.



The screenshot shows the 'BatteryMaterials' website interface. At the top, there are navigation links: 'Home', 'Upload new data', and 'Release Notes'. Below this is a descriptive paragraph about the project. A search bar is present with the text 'Enter a RefCode' and a magnifying glass icon. Below the search bar, there are radio buttons for 'ICSD' (selected) and 'Battery Materials Database'. Below that, it says 'or' and 'You chose: Ca'. At the bottom, a periodic table is displayed with Calcium (Ca) highlighted in blue.

Figure 1. An example of <https://batterymaterials.info> search page.

## References

- [1] Tarascon, Jean-Marie. **2020**, *Joule* 4(8), 1616-1620.
- [2] Leisegang T., Meutzner F., Zschornak M., Münchgesang W., Schmid R, Nestler T., Meyer D.C. **2019**, *Frontiers in chemistry*. **2019**, 4, 268.
- [3] Nestler T., Meutzner F., Kabanov A.A., Zschornak M., Leisegang T., Meyer D.C. *Chemistry of Materials*. **2019**, 31(3), 737-747.
- [4] Morkhova E.A., Kabanov A.A., Blatov, V.A. *Russian Journal of Electrochemistry*. **2019**, 55(8), 762-777.
- [5] Morkhova E., Rothenberger M., Leisegang T., Adams S., Blatov V., Kabanov A. *submitted to The Journal of Physical Chemistry C*. **2021**.

Acknowledgements. This work was supported by the Russian Science Foundation (project No 19-73-10026) and the German Federal Ministry of Education and Research (R2RBattery: 03SF0542A).

## COARSE-GRAINED APPROACHES FOR CALCULATION OF SPARINGLY SOLUBLE DRUG COMPOUNDS SOLUBILITY IN SCCO<sub>2</sub>

*Kalikin N.N.*<sup>1</sup>, *Budkov Y.A.*<sup>1,2</sup>, *Kolesnikov A.L.*<sup>3</sup>, *Ivlev D.V.*<sup>1</sup>, *Krestyaninov M.A.*<sup>1</sup>, *Kiselev M.G.*<sup>1</sup>

<sup>1</sup>G.A. Krestov Institute of Solution Chemistry of the Russian Academy of Sciences, Russia

<sup>2</sup>Tikhonov Moscow Institute of Electronics and Mathematics, National Research University Higher School of Economics, Russia

<sup>3</sup>Institut für Nichtklassische Chemie e.V., Germany

[nnk@isc-ras.ru](mailto:nnk@isc-ras.ru)

We propose two coarse-graining approaches to compute the solubility of sparingly soluble drug compounds in supercritical carbon dioxide [1,2]. The motivation of such a study lies in the fact that a sufficient percentage of the presented in the market active pharmaceutical ingredients have poor aqueous solubility leading to problems with their bioavailability. Supercritical technologies, useful nowadays for solubility enhancement (for example, supercritical micronization, cocrystallization), require fast and accurate methods for preliminary solubility estimation to assist when choosing the appropriate state parameters for the experimental procedures. The approach of the solubility calculation is based on the thermodynamic route consisting of the sublimation and solvation processes. We propose to take the sublimation data from the experimental data, available in the literature. We compute the solvation free energy with the help of the classical density functional theory and the molecular dynamics simulation of the Lennard-Jones fluid. Such coarse-graining of the solvent and solute molecules can be justified since the studied systems do not have any specificity in the intermolecular interactions. Thus the main contribution to the interactions is the Van der Waals forces, which can be modeled via the Lennard-Jones potential. The functional, proposed within the classical density functional approach consists of the hard-sphere contribution, interparticle attraction in the mean-field approximation, and the external potential, representing the solute particle. Solving the Euler-Lagrange equation leads to the equilibrium density profile. The solvation free energy can then be obtained as the difference between the grand thermodynamic potentials of the perturbed and non-perturbed fluids. Fitting the solute and solvent critical points using the WCA equation of state to the known from the literature ones allows us to obtain the parameters of the intermolecular interaction potential. These are the only input parameters, needed for the solvation free energy computation with the proposed method. The coarse-grained molecular dynamics simulation is based on the simulation of the Lennard-Jones fluid, whose parameters of the intermolecular potential we determine via the rule of the corresponding states. We have taken the critical parameters of the Lennard-Jones fluid from the literature data, obtained by the grand canonical Monte Carlo simulation. The solvation free energy is then determined using the Bennett Acceptance Ratio approach. The results of the proposed approaches are in decent agreement with the literature experimental solubility data and predict the location of the crossover points [3,4]. The computation process is much faster than that of the fully atomistic computer experiments while the number of the input parameters is lower than that required to estimate solubility with the equations of state.

### References

- [1] Kalikin, N.N., Budkov, Y.A., Kolesnikov, A.L., Ivlev, D.V., Krestyaninov, M.A., Kiselev, M.G. **2021**. arXiv preprint arXiv:2105.07240.
- [2] Budkov, Y.A., Kolesnikov, A.L., Ivlev, D.V., Kalikin, N.N., Kiselev, M. G. **2019**. *Journal of Molecular Liquids*, 276, 801-805.
- [3] Kalikin, N.N., Oparin, R.D., Kolesnikov, A.L., Budkov, Y.A., Kiselev, M.G. **2021**. *Journal of Molecular Liquids*, 334, 115997.
- [4] Kalikin, N.N., Kurskaya, M.V., Ivlev, D.V., Krestyaninov, M.A., Oparin, R.D., Kolesnikov, A.L., Budkov, Y.A., Idrissi A., Kiselev, M.G. **2020**. *Journal of Molecular Liquids*, 311, 113104.

Acknowledgements. This work was supported by Russian Foundation for Basic Research (project No 18-29-06008).

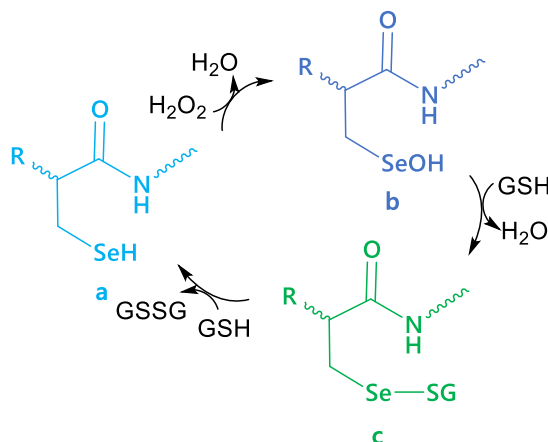
# AB INITIO SIMULATION OF THE GLUTATHIONE PEROXIDASE-1 CATALYTIC CYCLE USING SELENCYSTEINE AS A MODEL SYSTEM

*Karpov V.V.<sup>1</sup>, Tupikina E.Yu.<sup>1</sup>*

<sup>1</sup>Saint Petersburg State University, Saint Petersburg, Russia  
Student  
[st055697@student.spbu.ru](mailto:st055697@student.spbu.ru)

This work is devoted to a simulation of the glutathione peroxidase-1 (GPx1) catalytic cycle (Figure 1). Enzymes of glutathione peroxidase family metabolize hydrogen peroxide ( $H_2O_2$ ) and lipid peroxides ( $RHO_2$ ), preventing oxidative stress of body cells. [1] For instance, GPx1 catalyzes reduction of  $H_2O_2$  in cytoplasm and mitochondria as follows. A selenocysteine residue **a**, being a part of the GPx1 active site, undergoes oxidation by a hydrogen peroxide molecule. This leads to a formation of an oxidized enzyme form **b** with an SeOH group. After that a cofactor molecule, glutathione (GSH), attacks the oxidized residue providing the reduction of an active site to moiety with a sulfur-selenium bond **c**. Finally, the complete regeneration of an active site takes place with another glutathione molecule, its attack leads to a breaking of a Se-S bond giving rise to the initial **a** form.

In our previous work we demonstrated that selenium outer electronic shell is sensitive to its immediate environment. [2] For this very reason, firstly, we take into account the influence of neighbouring amino acid residues – glutamine and tryptophane that are also present in the active site and form hydrogen bonds with selenium atom. The vacant coordination spots are filled with water molecules, since they can incorporate inward enzyme in real systems. It is important to emphasize that the water saturation is performed using explicit solvent simulation. Although it is more time-consuming but we believe this is crucial for better prediction of thermodynamic properties.



**Figure 1.** The catalytic cycle of hydrogen peroxide reduction by GPx1.

The choice of selenium-containing glutathione peroxidase as an object for our investigation was driven by their prevalence in human body over sulfur-containing analogues. Moreover, there is a selenium-containing potential drug Ebselen [3] showing high anti-inflammatory, antioxidant and cytoprotective activity. It is being under controlled clinical trial at the moment. [4] Thus, the investigation of ours might shed light on some mechanistic features of the GPx cycle and is capable to assist in finding the optimal route to the new generation antioxidant drugs.

## References

- [1] Brigelius-Flohé R., Maiorino M. *Biochim. Biophys. Acta.* **2013**, *1830*, 3289–3303.
- [2] Tupikina E. Yu., Karpov V.V., Tolstoy P. *Phys. Chem. Chem. Phys.* **2021**, just accepted.
- [3] Müller A., Cadenas E., Graf P., Sies H. *Biochem. Pharmacol.* **1984**, *33*, 3235–3239.
- [4] Kil J., Lobarinas E., Spankovich C., Griffiths S. K., Antonelli P. J., Lynch E. D., Le Prell C. G. *Lancet* **2017**, *390*, 969–979.

Acknowledgements. This work was supported by the Russian Science Foundation (project No 20-73-00099).

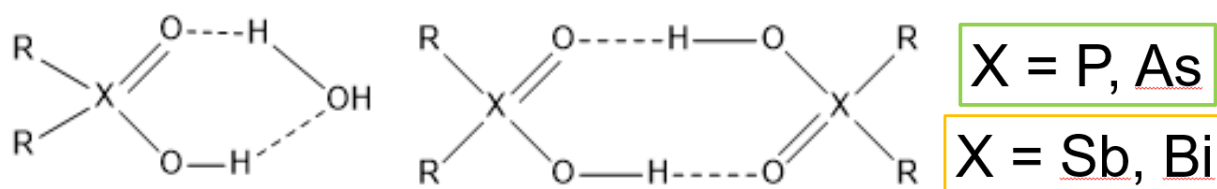
THE STABILITY OF STILBINIC AND BISMUTHINIC ACID COMPARED TO ARSINIC ACIDS ASSISTED BY HYDROGEN BONDING: AB INITIO INVESTIGATION

*Korostelev V.O.,<sup>1</sup>Tupikina E.Y.<sup>1</sup>*

<sup>1</sup>Saint Petersburg State University, Saint Petersburg, Russia  
1<sup>st</sup> year master student  
[vladfromlive@yandex.ru](mailto:vladfromlive@yandex.ru)

It is well known that carboxylic RCOOH and phosphinic RR'POOH acids exist in gas, solution and in solid states as hydrogen-bonded complexes. Such acids containing XOOH group (X = C, P) can participate in hydrogen bonding both as donors (by XOH moiety) and acceptors (by X=O moiety). Thus, such molecules form various homo-complexes (dimers, trimers etc.) as well as hetero-complexes XOH...B (B – base) or X=O...HA (HA – acid). Carboxylic RCOOH and phosphinic RR'POOH acids and their hydrogen bonded complexes are widely explored by experimental techniques such as IR and NMR spectroscopies as well as by quantum chemistry methods [1,2].

The amount of published information by moving down a group in the periodic table (from P to As atom, as an X atom) from phosphinic RR'POOH acids to arsinic R<sub>2</sub>AsOOH acids is dramatically decreases. Most commonly used arsinic R<sub>2</sub>AsOOH acids for vast research interests are diphenylarsinic or dimethylarsinic acid (also well known as cacodylic acid), which are stable compounds and exist observed both in solution and crystalline states [3]. Ability of arsinic acids R<sub>2</sub>AsOOH to form hydrogen-bonded homo- and hetero-complexes and features of their electronic shells that lead to diverse crystalline polymorphs, is practically unexplored area or research [4].



**Figure 1.** Hydrogen-bonded complexes formed by R<sub>2</sub>XOOH acids: complex with a water molecule (left) and homo-dimer (right).

At the same time compounds with general formula RR'XOOH (where X = Sb, Bi), those can be named as stilbinic R<sub>2</sub>SbOOH and bismuthinic R<sub>2</sub>BiOOH acids, are not presented in literature at all. Moreover, there is no sufficient evidence of such acids being synthesized in the first place, same can be said about absolute absence of theoretical works in this area of study.

This work is devoted to the quantum-chemical investigation (MP2/def2-TZVP) of geometries, electronic structure and thermochemistry of stilbinic R<sub>2</sub>SbOOH and bismuthinic R<sub>2</sub>BiOOH acids both in vacuum ( $\epsilon=1$ ) and in isotropic polarized media ( $\epsilon=40, 81$ ) compared to stable arsinic R<sub>2</sub>AsOOH acids.

### References

- [1] Giba I. S., Mulloyarova V. V., Denisov G. S, Tolstoy P. M. *Magn. Reson. Chem.* **2021**, *59*, 465.
- [2] Mulloyarova V. V., Ustimchuk D. O., Filarowski A., Tolstoy P. M. *Molecules* **2020**, *25*, 1907.
- [3] Reid J. W., *Powder Diffr.* **2021**, 1-6.
- [4] Mulloyarova V. V., Puzyk A. M., Efimova A. A., Antonov A. S., Evarestov R. A., Aliyarova I. S., Asfin R. E., Tolstoy P. M. *J. Mol. Struct.* **2021**, *1234*, 130176.

Acknowledgements. This work was supported by RFBR grant 20-03-00231.

# QUANTUM-CHEMICAL ANALYSIS OF THE EFFECT OF WATER AND METHANOL MOLECULES ON THE KINETICS OF 2-METHYLIMIDAZOLE FORMATION

*Kotov A.V.<sup>1</sup>, Vodyankina O.V.<sup>1</sup>, Fateev A.V.<sup>1,2</sup>, Tuguldurova V.P.<sup>1</sup>*

<sup>1</sup>Tomsk State University, Tomsk, Russia

<sup>2</sup>Tomsk State Pedagogical University, Tomsk, Russia

[asdfec01@yandex.ru](mailto:asdfec01@yandex.ru)

Imidazole and its derivatives are used in production of drugs, powder paints and agricultural chemicals [1,2]. 2-methylimidazole can be obtained by the interaction of acetaldehyde, glyoxal and ammonia in an aqueous solution [3]. The reaction does not require a catalyst, and the reagents and solvent are widely available. Currently, the mechanism of this reaction has been insufficiently studied. In the literature there are no data about the effect of solvent molecules on reaction pathway of 2-methylimidazole formation, but there are articles about solvent effect on similar reactions [4]. The study of the reaction mechanism of the formation of 2-methylimidazole by experimental methods is complicated, however, quantum-chemical methods can provide the required information.

The structures of all initial and intermediate substances as well as reaction products were optimized. Transition states (TS) for all stages of the reaction of acetaldehyde, glyoxal and ammonia without explicit solvent molecules were found. Also, TS for all stages of the reaction with the participation of one and two explicit water molecules and methanol molecules were found. Geometry optimization of all the structures was carried out using the Gaussian'16 program package installed at the ANNEMARIE – Cluster of the Philipps-Universität Marburg. Calculation with the B3LYP-D3/6-311G(d,p) level of theory was used. The geometries of the stable conformers for each molecular structure and transitional states were optimized in the solution by using the PCM model. The thermochemical data were recalculated by using the low-frequency corrections and correction from gas with the pressure of 1 atm to solution with a concentration of 1 mol l<sup>-1</sup> by using the GoodVibes script. The calculation scheme that adequately describes the experimental data was proposed [5].

All stages of the interaction of acetaldehyde, glyoxal, and ammonia were divided by types: nucleophilic addition ( $\Delta G^\ddagger \sim 33.7$  kcal mol<sup>-1</sup>,  $\Delta H^\ddagger \sim 22.2$  kcal mol<sup>-1</sup>), dehydration of aminoalcohols ( $\Delta G^\ddagger \sim 45.2$  kcal mol<sup>-1</sup>,  $\Delta H^\ddagger \sim 45.9$  kcal mol<sup>-1</sup>), hydrogen transfer ( $\Delta G^\ddagger = 29.4$  kcal mol<sup>-1</sup>,  $\Delta H^\ddagger = 29.4$  kcal mol<sup>-1</sup>). The investigation showed that the enthalpy of activation decreased by 25 – 30 kcal mol<sup>-1</sup> and the Gibbs activation energy decreased by 20 – 25 kcal mol<sup>-1</sup> when one water molecule was included into the TS structure. When two water molecules were included into the TS structures, the enthalpy of activation and the Gibbs energy of activation decreased by 35 – 40 kcal mol<sup>-1</sup> and 30 – 35 kcal mol<sup>-1</sup>, respectively.

The enthalpy of activation decreased by 27 – 32 kcal mol<sup>-1</sup>, the Gibbs activation energy decreased by 22–27 kcal / mol when one methanol molecule was included into the TS structure. The enthalpy of activation and the Gibbs energy of activation decreased by 47 – 49 kcal mol<sup>-1</sup> and 34 – 37 kcal mol<sup>-1</sup> when two methanol molecules were included into structures.

The barriers had decreased when the number of solvent molecules in the structure of transition states increased. It occurred due to the formation of stable six- and eight-center cycles providing proton transfer.

The most probable reaction pathway was determined. The highest barriers ( $\Delta G^\ddagger = 23.4$  kcal mol<sup>-1</sup>,  $\Delta H^\ddagger = 22.0$  kcal mol<sup>-1</sup>) were observed for the cyclization stage. This was the rate-limiting stage. Cyclization proceeded according to the S<sub>N</sub>2 type. In this step, the increase of the number of water or methanol molecules from one to two led to an increase in the Gibbs activation energy and the enthalpy of activation.

## References

- [1] Kumari S., Pramod K.S., Nitin K. Imidazole and its biological activities: A review. *Der Chemica sinica*. **2010**, 1(3), 36–47.
- [2] Olivier-Bourbigou H., Magna L., Morvan D. Ionic liquids and catalysis: Recent progress from knowledge to applications. *Appl. Catal. A: General*. **2010**, 373, 1–56.
- [3] Malkov V. S., Knjazev A. S., Kotelnikov O. A., Odnokopylova M. V. Method for preparing 2-methylimidazole RF patent No. 2486176. Claim. **17.11.2011**. Publ. 27.06.2013.
- [4] Sarkar S., Oram B. K., Bandyopadhyay B. Ammonolysis as an important loss process of acetaldehyde in the troposphere: energetics and kinetics of water and formic acid catalyzed reactions. *Physical Chemistry Chemical Physics*. **2019**, 21(29), 16170-16179.
- [5] Tuguldurova, Vera P., et al. Theoretical analysis of glyoxal condensation with ammonia in aqueous solution. *Physical Chemistry Chemical Physics* **2019**, 21(18), 9326-9334.

# QUANTUM CHEMICAL MODELING OF THE ELECTRON-VIBRATIONAL SPECTRA OF AZULENE AND ITS DERIVATIVES

*Kozina D.O.,<sup>1</sup> Porsev V.V.<sup>1</sup>*

<sup>1</sup>Saint Petersburg State University, Saint Petersburg, Russia

[kozina.d@yandex.ru](mailto:kozina.d@yandex.ru)

Azulene has become a popular structure for the study of its photophysical properties due to its fluorescence against the Kasha's rule. This unique feature allows the use of azulene derivatives in bioimaging, as well as as organic light-emitting diodes (OLED), molecular switches, etc. It is important to study how the spatial and donor-acceptor properties of substituents in azulene affect the color and intensity of absorption and phosphorescence of its derivatives. This knowledge will create the ability to control these properties: "select" the radiation channel and "adjust" the color of the emission. However, there is a problem, because a simple simulation of absorption and emission spectra using the time-dependent density functional theory (TD DFT) does not allow to observe in the spectra the bands corresponding to existing transitions, to reproduce the correct ratio of their intensities, this method does not describe the vibrational resolution. We use a method based on the Frank-Condon principle for estimating the intensity of transitions between the vibrational levels in a molecule. This computational approach makes it possible to solve both problems outlined above. [1]

In this work, we have studied two series of azulene derivatives: with a donor methoxy group ( $-\text{OCH}_3$ ) and an acceptor cyano group ( $-\text{CN}$ ) introduced to each carbon atom of the azulene system consecutively. For these series, absorption and fluorescence spectra corresponding to the transitions between ground and first and second excited singlet states were calculated. The obtained spectra show that the shape of the lines and their intensity agree with the experimental results. In addition, the shifts of the maxima and the changes in the shape of lines in the spectra as well as the fluctuations corresponding to the most intense transitions were analyzed.

## References

[1] Barone V., Bloino J., Biczysko M. *GAUSSIAN 09 Revision A.02*. 2009.

Acknowledgements. This work was supported by the Russian Science Foundation (project No 19-73-20055).

QUANTUM CHEMICAL STUDY OF CORRELATIONS BETWEEN BONDS' NATURE, MEROCYANINE STABILITY AND POSITIONS OF SUBSTITUENTS FOR SPIROPYRANS CONTAINING CONJUGATED CATIONIC 3H-INDOLIUM FRAGMENT

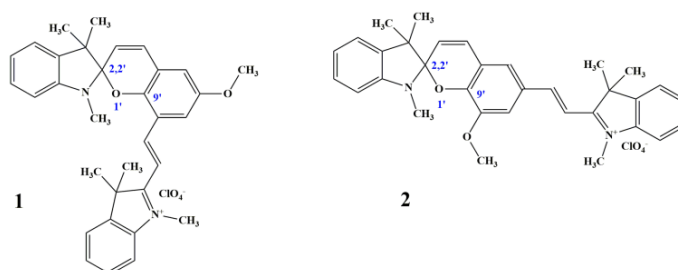
Kozlenko A.S.,<sup>1</sup> Koval V.V.,<sup>1</sup> Pugachev A.D.,<sup>1</sup> Lukyanova M.B.,<sup>1</sup> Ozhogin I.V.,<sup>1</sup> Bykusov V.V.,<sup>1</sup> Lukyanov B.S.<sup>1</sup>

<sup>1</sup>Institute of Physical and Organic Chemistry, Southern Federal University, Rostov-on-Don, Russia  
PhD student

[anastasiya.kozlenko@gmail.com](mailto:anastasiya.kozlenko@gmail.com)

Spiropyrans are a promising type of organic molecular switches that act based on reversible isomerization reaction. The properties of closed spirocyclic (SP) and opened merocyanine (MC) forms differ significantly that allows to create a wide range of smart materials based on them [1]. Currently, special interest is attracted by cationic spiropyrans' derivatives due to the possibility of hybrid multifunctional materials design [2].

Spiropyrans' properties strongly depend on the electronic effect and location of substituents in the 2H-chromene moiety that allows tuning systems' characteristics quite accurately [3]. The bright examples of this strong dependence are compounds **1** and **2** containing electron-donating methoxy group and electron-withdrawing conjugated 3H-indolium substituent. In general, the compounds of this type are characterized by the strong bathochromic shift of absorption maxima of both SP and MC forms due to elongation of the conjugation chain. Therefore, they attract great interest as molecular switches perspective for applying in molecular electronics and bioimaging. The spiropyrans **1** and **2** are characterized by different thermodynamic stability of their MC form in solutions and crystallizes in SP and MC forms respectively [4].



In this work the relative stability of different spiropyrans' isomers and bonds' character near the C<sub>spiro</sub>-O bond have been investigated using DFT approach to explain the nature of the aforementioned effects. Firstly, it was established that anion affects significantly the relative energies of different forms, and the comparison with experimentally observed phenomena indicates the importance of taking anion into account anyway. In the case of compounds **1** and **2**, the energy gaps ( $\Delta E_{\text{tot}}$ ) between *cis*-isomer and SP form are 6,53 and 3,54 kcal/mol respectively. The *trans*-isomer of compound **2** is more stable than the corresponding one for spiropyran **1** (11,2 and 7,37 kcal/mol respectively). To understand more clearly the influence of different substituents rearrangement on the C<sub>spiro</sub>-O bond reactivity (and ability of compounds to transform at ambient conditions) NBO analysis has been performed. It indicates that second-order interactions' energy between O(1') atom and aromatic system of the 2H-chromene moiety (particularly with C(9') atom) is much higher in the case of spiropyran **2** ( $E_{\text{st}} = 134,69$  kcal/mol) compared with **1** ( $E_{\text{st}} = 55,24$  kcal/mol). For interaction O(1')-C(2,2') energies are very close (13.09 kcal/mol in compound **1** and 13.63 kcal/mol for **2**). In spiropyran **2** multiplicity of O(1')-C(9') bond is close to double. Such disbalance in bonds' energies leads to easier C<sub>spiro</sub>-O bond cleavage that is in agreement with experimentally observed equilibrium between SP and MC.

Thus, the bonds' nature in the spiropyrans **1** and **2** were investigated. The imbalance in electron density was observed in O(1')-C(9') bond localization area, which leads to the destabilization of the SP isomer of compound **2**.

#### References

- [1] Klajn, R. Spiropyran-based dynamic materials *Chem. Soc. Rev.*, **2014**, *43*, 148–184.
- [2] Bénard, S., Rivière, E. A Photochromic Molecule-Based Magnet *Chem. Mater.*, **2001**, *13*, 159–162.
- [3] Balmond, E. I., Tautges, B. K., Faulkner, A. L., Or, V. W., Hodur, B. M., Shaw, J. T., Louie, A. Y. Comparative Evaluation of Substituent Effect on the Photochromic Properties of Spiropyrans and Spirooxazines. *J. Org. Chem.*, **2016**, *81*, 8744–8758.
- [4] Lukyanova, M. B., Tkachev, V. V., Lukyanov, B. S., Pugachev, A. D., Ozhogin, I. V., Komissarova, O. A., Aldoshin, S.M., Minkin, V. I. Structure Investigation of New Condensation Products of 1,2,3,3-Tetramethylindolenium with Metoxysubstituted Diformylphenols *J. Str. Chem.*, **2018**, *59*, 565–570.

Acknowledgements. This work was supported by a project of the Ministry of Science and Higher Education of the Russian Federation (project No. 0852-2020-00-19).

# MOLECULAR DYNAMICS AND DOCKING SIMULATIONS OF BINDING OF THE THIOUREA DINITROSYL IRON COMPLEX TO BOVINE SERUM ALBUMIN

*Krapivin V.B.*<sup>1</sup>, *Luzhkov V.B.*<sup>1,2</sup>

<sup>1</sup>Institute of Problems of Chemical Physics of RAS, Chernogolovka, Russia

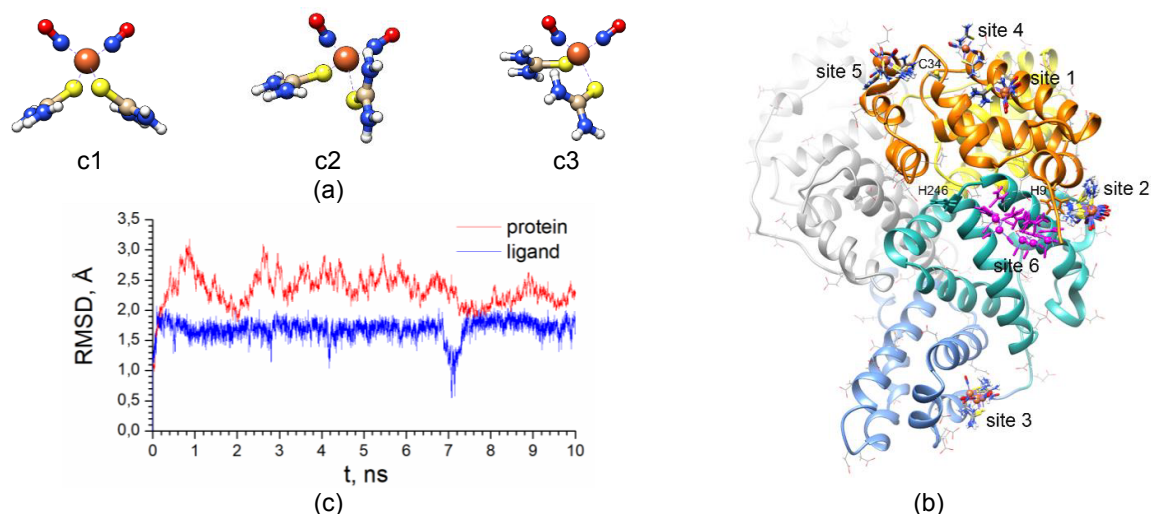
<sup>2</sup>Moscow State University, Moscow, Russia

PhD student

[krapivin-vb@mail.ru](mailto:krapivin-vb@mail.ru)

Nitrogen monoxide is a signaling molecule involved in the regulation of cardiovascular tone, neural transmission, apoptosis, and immune defense. Dinitrosyl iron complexes (DNICs) with sulfur-containing ligands are natural NO carriers that allows to consider them as perspective drugs. The advantages of DNICs as NO donors are the presence of two pharmacologically active fragments and low barrier to NO generation. *In vivo* DNICs can interact with plasma proteins containing thiol groups. The most common serum protein is albumin which is the main carrier of metabolites, hormones, ions and drugs. It can also bind coordination complexes of metals, in particular, a number of DNICs.

In this work the computational study of cationic complex  $[\text{Fe}(\text{NO})_2(\text{SC}(\text{NH}_2)_2)_2]^+$  (**1**) with bovine serum albumin (BSA) was carried out. The 3D structure of BSA was taken from the Protein Data Bank (PDB ID: 4f5s). The molecular and electronic structure of complex **1** in water was studied using DFT calculations at the B3LYP/6-311+G(2df,2p) level of theory with the polarizable continuum solvation model SMD. Three stable conformations of **1** (c1-c3) were found (Figure 1, a). For each conformer blind docking with rigid ligand geometry was performed. As a result of the docking procedure six low-energy binding sites (Figure 1, b) had been predicted at the interface between domains IA and IIA and domains IIA and IIB of BSA [1]. Sites 1 and 4 are located near Cys34 containing the free SH-group.



**Figure 1.** (a) The conformations of complex **1**, (b) six binding sites of complex **1** on the surface of BSA [1], (c) RMSDs of the protein and ligand positions after 10 ns MD simulation of the BSA-**1** complex in site 1.

The stability of the docked ligand positions on the protein surface was explored using the molecular dynamics (MD) simulations of the protein-ligand complexes with explicit TIP3P water molecules in a cubic box at 300 K. The required force field parameters related to the iron bonds and angles were obtained from the DFT calculations of compound **1**. The found value of the Fe-N force constant is close to the P-O bond constant in phosphate group, whereas the value of Fe-S force constant is much lower. The force constants for the angles S-Fe-S, N-Fe-N and S-Fe-N are lower than for the angles in phosphate group. The MD simulations of the protein-ligand complex at site 1 showed that this complex is stable on the albumin surface for 10 ns (Figure 1, c). This supports the experimental observations [1] that BSA can efficiently bind DNIC **1** that helps to prolong NO donation.

## References

[1] Pokidova O.V., Luzhkov V.B., Emel'yanova N.S., Krapivin V.B., Kotelnikov A.I., Sanina N.A., Aldoshin S.M. *Dalton Trans.* **2019**, *48*, 9328-9336.

Acknowledgements. This work was performed in accordance with the state task, state registration no. AAAA-A19-119071890015-6.



# NEW $\text{Bi}_2\text{Ti}_2\text{O}_7$ -BASED VISIBLE LIGHT ACTIVE PHOTOCATALYSTS: AB INITIO SCREENING AND EXPERIMENTAL SYNTHESIS

*Krasnov A.G.*<sup>1</sup>, *Shein I.R.*<sup>2</sup>, *Koroleva M.S.*<sup>1</sup>, *Vlasov M.I.*<sup>3,4</sup>, *Piir I.V.*<sup>1</sup>

<sup>1</sup>Institute of Chemistry, Federal Research Center Komi Science Center UB RAS, Syktyvkar, Russia

<sup>2</sup>Institute of Solid State Chemistry, UB RAS, Ekaterinburg, Russia.

<sup>3</sup>Ural Federal University, NANOTECH Center, Ekaterinburg, Russia

<sup>4</sup>Institute of High Temperature Electrochemistry, Ural Branch, Russian Academy of Sciences, Ekaterinburg, Russia

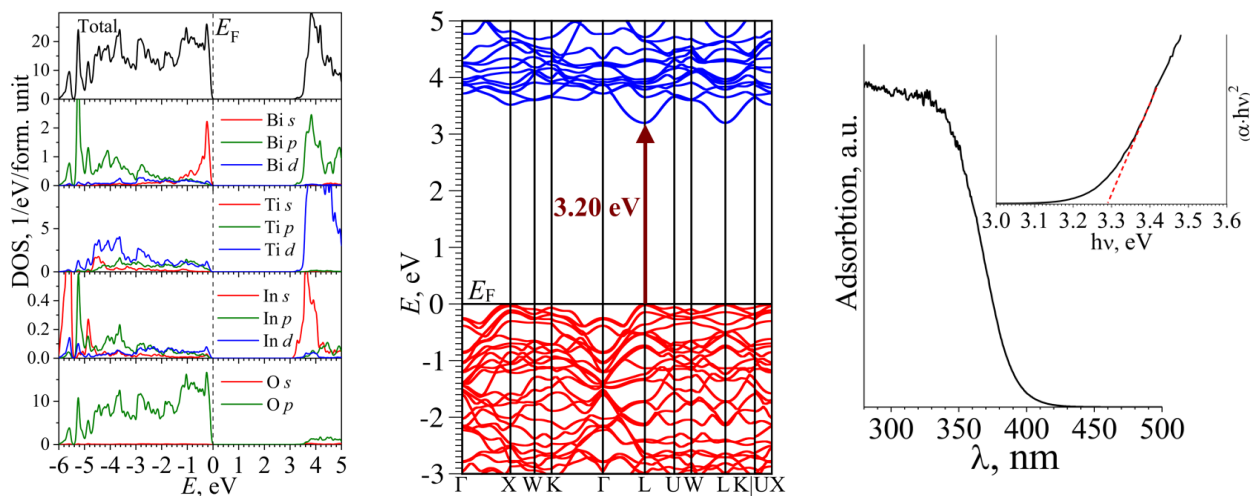
PhD, research associate

[alexey-krasnov@rambler.ru](mailto:alexey-krasnov@rambler.ru)

Advanced photochemical oxidation technologies based on heterogeneous photocatalysis processes with semiconductors are the most preferred purification methods. They offer the possibility of applying natural and renewable solar energy to purify water, air, and surfaces from organic pollutants (such as drugs, particularly paracetamol), making these processes environmentally friendly and economical.

Bismuth titanate pyrochlore  $\text{Bi}_2\text{Ti}_2\text{O}_7$  is stated to be a perspective photocatalyst [1,2]. Several strategies are known to enhance the photocatalytic activity of the single material photocatalysts in visible light, e.g., the optimization of crystal structure, surface area, morphology; the manipulation of native defects; doping to adjust the optoelectronic properties.

In the present work, combined *ab initio* and experimental investigation were performed. All calculations were conducted by means of the DFT using the PAW method as implemented in the VASP. The GGA-PBE formalism was used to describe exchange-correlation effects during geometry optimization. Doping in the pyrochlore structure was simulated by the substitution of 25 at.% Bi atoms with Al, Ga, In, Sc. We employed the screened Coulomb hybrid HSE03 exchange-correlation functional to accurately calculate the total and partial density of states, the band structure, and optical parameters of doped models. The group-III elements doped pyrochlore  $\text{Bi}_2\text{M}_x\text{Ti}_2\text{O}_7$  ( $M = \text{Al}, \text{Ga}, \text{In}, \text{Sc}$ ) photocatalysts were obtained by a coprecipitation method [2]. Characterization of the properties of the compounds by a complex of physicochemical methods (XRD, SEM-EDX, TEM, DSC, dynamic light scattering method, low-temperature physical method nitrogen sorption, diffuse scattering spectroscopy) was carried out. The ability to decompose organic dye RhB and paracetamol in aqueous solutions was revealed during the photocatalytic tests under visible light irradiation.



**Figure 1.** Electronic structure and experimental absorption spectrum of the  $\text{Bi}_{1.5}\text{In}_{0.5}\text{Ti}_2\text{O}_7$  pyrochlore.

## References

- [1] Noureldine D., Lardhi S., Ziani A., Harb M., Cavallo L., and Takanabe K., *J. Mater. Chem. C*, **2015**, *3*, 12032–12039.
- [2] Krasnov A.G., Napalkov M.S., Vlasov M.I., Koroleva M.S., Shein I.R., and Piir I.V., *Inorg. Chem.*, **2020**, *59*, 12385–12396.

**Acknowledgments.** The research was done using the equipment of Center for Collective Use «Khimiya» of Russian Academy of Sciences Ural Branch Federal Research Center Komi Science Center Institute of Chemistry; Center for Collective Use of IMM UrB RAS "Supercomputer Center URAN IMM UrB RAS." This work was supported by the Council on grants of the President of the Russian Federation (MK-310.2021.1.3).

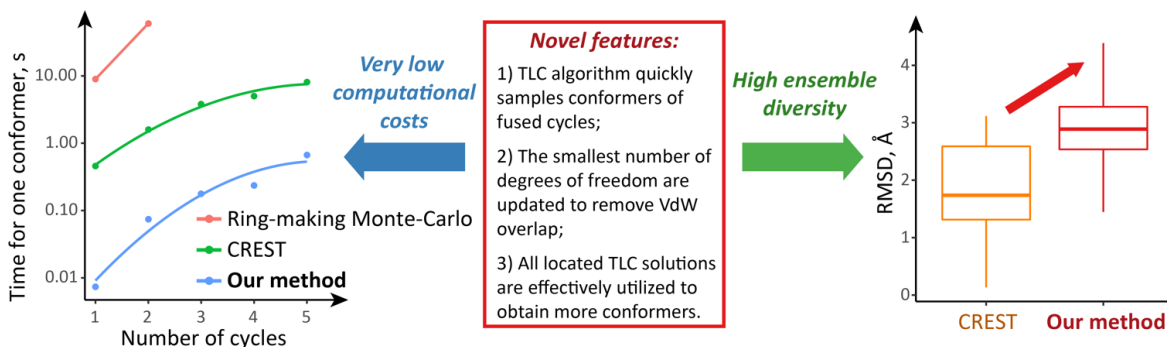
# OPEN-SOURCE ALGORITHM FOR GLOBAL CONFORMATIONAL SEARCH OF CYCLIC MOLECULES AND TRANSITION STATES

*Krivoshchapov N.V.<sup>1</sup>, Medvedev M.G.<sup>1</sup>*

<sup>1</sup>Zelinsky Institute of Organic Chemistry RAS, Moscow, Russia  
Student  
[knvvv@yandex.ru](mailto:knvvv@yandex.ru)

The accuracy of quantum chemical modeling of any reaction strongly depends on the completeness of the conformational ensemble of all considered molecules and transition states (TSs). The absence of one of the low-energy conformations in the ensemble can significantly affect the computed molecule's energy and distort the results of modeling the reaction. Overlooking the optimum TS so that the best located is only 1 kcal/mol above the correct value can lead to an error in the predicted ratios of reaction products exceeding 50%. Thus, adequate modelling of a chemical reaction requires thorough conformational analysis of all key TSs and intermediates (see [1-2] for examples). However, for the majority of practically important molecules, the problem of conformational search is complicated by the presence of fused and/or free cycles, which conformations always interconvert by changing several dihedral angles. This problem makes the traditional approach—ring-making Monte-Carlo, based on random choice of dihedral angles—ineffective. To our knowledge, there is only one algorithm called TLC [3] which effectively solves the problem of sampling conformations of cycles. This method employs the geometric approach to conformational search by generating cycle conformers strictly satisfying given constraints on bond lengths and valence angles. However, TLC can not be applied to polycyclic frameworks, making it inapplicable to most common organic molecules.

We propose the algorithm that greatly generalizes the scope of TLC to molecules with one or several fragments containing free and/or fused cycles. We also developed a user-friendly implementation of this algorithm that will be made open source by September 2021. Besides applicability to fused cycles, we aimed to make generated conformers useful for further geometry optimization, therefore, detection of unwanted Van-der-Waals atomic overlaps was implemented. In order to eliminate detected overlaps, our implementation attempts to change as little dihedral angles as possible. Given that these angles are chosen properly, the chances of successful elimination of VdW contacts become a lot greater. Moreover, the algorithm can be applied for conformational search of TSs by constraining interatomic distances for closing and breaking bonds [4].



**Figure 1.** Comparison of proposed algorithm with meta-MD and traditional Monte-Carlo by speed for different number of cycles in molecule (the left plot, note the logarithmic scale on time axis) and only with MTD by diversity of generated conformers (the right plot).

Figure 1 compares performance of proposed algorithm with meta-MD sampling implemented in recent conformational search code CREST [4]. Our algorithm shows itself as a better global sampling method due to significantly higher average RMSD of generated ensemble. Moreover, our implementation clearly outperforms meta-MD by at least an order of magnitude making possible sampling of one hundred reasonable conformers of five fused cycles without parallelization in a couple of minutes!

## References

- [1] Yaremenko I.A., Medvedev M.G., Krivoshchapov N.V. et al. *J. Am. Chem. Soc.* **2021**, *143*, 17, 6634–6648.
- [2] Yaremenko I.A., Medvedev M.G., Krivoshchapov N.V. et al. *J. Am. Chem. Soc.* **2020**, *142*, 34, 14588–14607.
- [3] Coutsiias E.A., Seok C., Jacobson M.P., Dill K.A. *Journal of Computational Chemistry*. **2004**, *25*, 4, 510–528.
- [4] Pracht P., Bohle F., Grimme S. *Phys. Chem. Chem. Phys.* **2020**, *22*, 14, 7169–7192.

# ALTERATION OF SUPERATOM MOLECULAR ORBITALS OF Li@C<sub>60</sub> DEPOSITED ON Cu(111) SURFACE

*Kuklin A.V.<sup>1</sup>, Yamada Y.<sup>2</sup>*

<sup>1</sup>Siberian Federal University, Krasnoyarsk, Russia

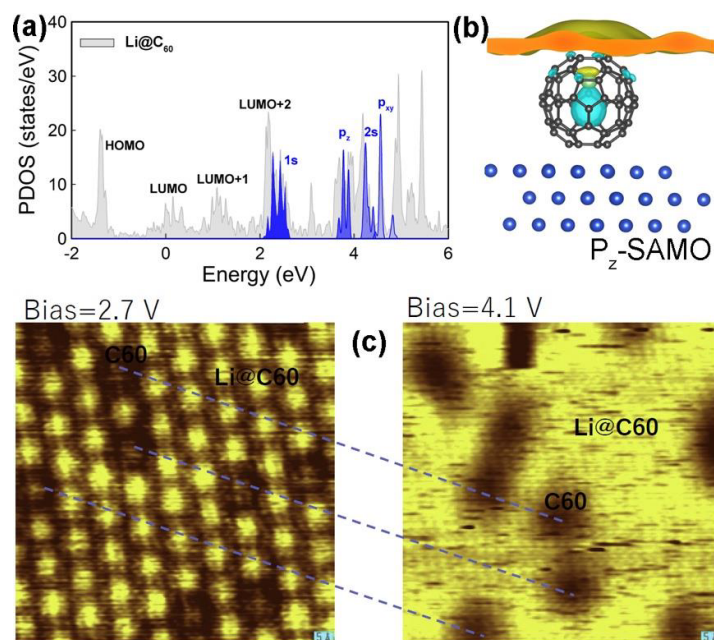
<sup>2</sup>University of Tsukuba, Tsukuba, Japan

Senior research scientist

[artem.icm@gmail.com](mailto:artem.icm@gmail.com)

Superatom molecular orbitals (SAMOs) have recently attracted significant interest [1] especially in the case of highly symmetric C<sub>60</sub> molecule revealing their delocalized and well-oriented nature allowing one to realize a well-controlled overlap between adjacent molecules and therefore promoting so called nearly free electron states (NFE) for effective electron transfer in organic materials. SAMOs of the free C<sub>60</sub> molecule has been rather widely studied, while SAMOs of the adsorbed molecules has not been known, in spite of its importance in a practical application, for instance, in weak electron-phonon interaction responsible for cooling of hot carriers [2]. Moreover, study of Li@C<sub>60</sub> molecule is especially interesting with respect to SAMOs [3], because its energy is relatively close to the Fermi level with possible contribution to transport and optical properties.

Employing density functional theory (DFT) calculations and scanning tunneling microscopy (STM), we directly show the spatial and energetic distribution of the delocalized superatom molecular orbitals (SAMO) of Li@C<sub>60</sub> and their features depending on Li position inside the fullerene cage and coupling with the Cu(111) surface. Real STM images exhibit isotropic and delocalized nearly free electron like states in Li@C<sub>60</sub> islands. They are compared and discussed in terms of theoretical results and simulated STM images.



**Figure 1.** (a) Partial DOS of Li@C<sub>60</sub> on Cu(111); (b) side view of P<sub>z</sub>-SAMO wavefunction; (c) Bias-dependent STM images of the Li@C<sub>60</sub> monolayer.

## References

- [1] Feng, M.; Zhao, J.; Petek, H. *Science* 2008, 320, 359–363.
- [2] Guo, H.; Zhao, C.; Zheng, Q.; Lan, Z.; Prezhdo, O. V.; Saidi, W. A.; Zhao, J. *J. Phys. Chem. Lett.* 2018, 9, 3485–3490.
- [3] Yamada, Y.; Kuklin, A. V.; Sato, S.; Esaka, F.; Sumi, N.; Zhang, C.; Sasaki, M.; Kwon, E.; Kasama, Y.; Avramov, P. V.; et al. *Carbon* 2018, 133, 23–30.

This work was supported by the Russian Science Foundation (project No 19-73-10015).

# CYCLOADDITION REACTION OF BENZYL VINYL ETHER TO NITRILE OXIDES: A COMPARATIVE QUANTUM-CHEMICAL STUDY OF REACTION PATHWAYS

*Kutskaya A.M.*<sup>1</sup>, *Polynski M.V.*<sup>1,2</sup>

<sup>1</sup> Saint Petersburg State University, Saint Petersburg, Russia

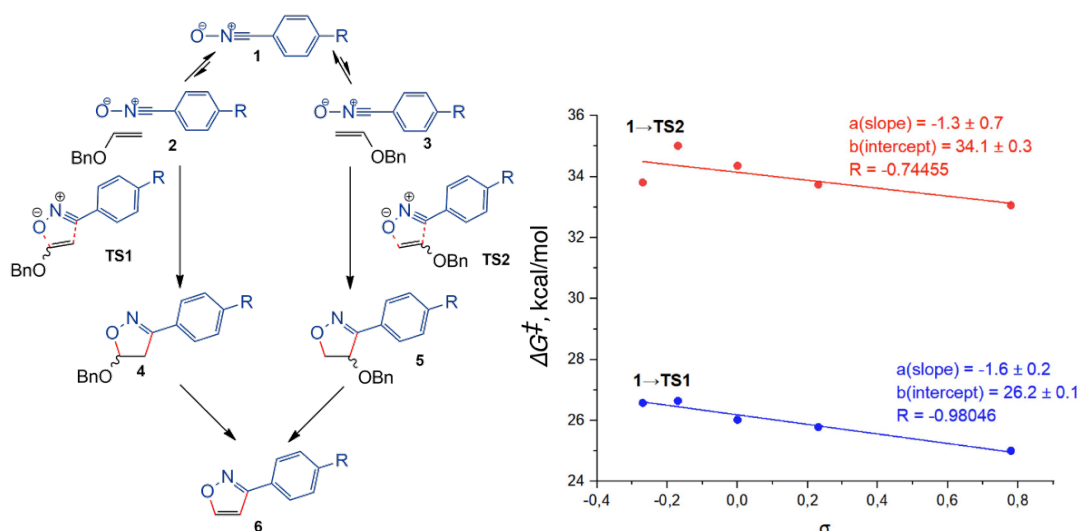
<sup>2</sup> Zelinsky Institute of Organic Chemistry, Moscow, Russia

BSc student

[st077231@student.spbu.ru](mailto:st077231@student.spbu.ru)

One of the most successful synthetic approaches in organic chemistry, directed at producing new carbo- and heterocyclic systems, are dipolar cycloaddition reactions. Here we studied the formation of isoxazoles from nitrile oxides by addition of benzyl vinyl ether (Figure 1, *left*). The products of these transformations, substituted isoxazoles, are can be used in pharmacology and in the synthesis of some commercially available drugs. [1-3]

In this work we performed quantum-chemical modeling of the cycloaddition reaction of benzyl vinyl ether to substituted nitrile oxides (R = H, Br, Me, OMe, NO<sub>2</sub>). We modeled the structures of reactants, pre-reaction and transition states, final products of cycloaddition reaction, calculated total electronic energies and thermodynamic functions (enthalpy, Gibbs free energy) of compounds. For both pathways (Figure 1, *left*), thermodynamic and kinetic parameters were compared. The substituent effect was evaluated by performing a Hammett study *in silico* (Figure 1, *right*).



**Figure 1.** *Left*: model reaction mechanism; *right*: the Hammett plot in which  $\Delta G^\ddagger$  along both reaction pathways are compared.

DFT calculations were performed with ORCA 4.2.1. Geometry optimizations and vibrational frequencies calculations were performed at two levels of the theory: B97-3c and PBE0-D4/def2-TZVP. The range-separated hybrid functional wB97X-V and def2-TZVP was also used for single point energy evaluations at optimized geometries. The SMD approach was used to simulate the reaction medium (benzene solution).

## References

- [1] Zhu J. et al. *Bioorg. and Med. Chem.* **2018**, 12, 3065–3075.
- [2] Lamberth C, *J. Heterocyclic Chem.* **2018**, 9, 2035–2045.
- [3] Ledovskaya M.S. et al. *European J. Org. Chem.* **2020**, 29, 4571–4580.

Acknowledgements. The work was supported by the Russian Science Foundation (Project № 19-7310032).

# THEORETICAL APPROACH TO DEEP EUTECTIC SOLVENTS DEVELOPMENT

*Lavrinenko A.K.<sup>1</sup>, Chernyshov I. Yu. <sup>1</sup>, Pidko E.A.<sup>1,2</sup>*

<sup>1</sup>ITMO University, Saint Petersburg, Russia

<sup>2</sup>Delft University of Technology, Delft, Netherlands

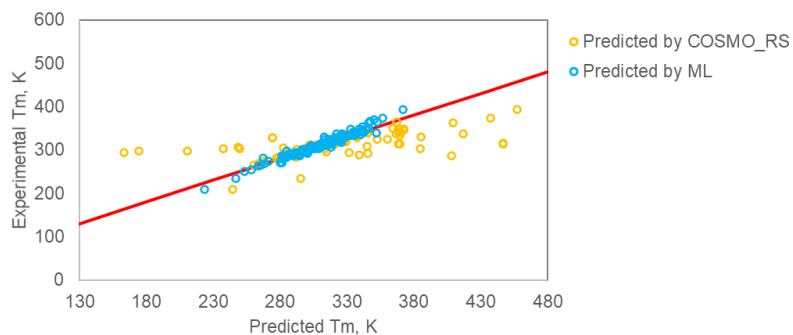
Student

[lavrinenko@scamt-itmo.ru](mailto:lavrinenko@scamt-itmo.ru)

Deep eutectic solvents (DESs) were discovered as a new class of green solvents and attracted high interest of researchers in various fields of science. Multiple hydrogen bonding between DES components leads to formation of eutectic mixture with significantly lower melting point in comparison with initial compounds [1]. Currently, new DESs are developing by experimental approach that consumes time and resources [1,2]. To the best of our knowledge, there is no general theoretical method presented in the literature of DES components selection or eutectic point prediction algorithm successfully applied to DESs. Hence, the aim of our research is to identify the limitations and possible opportunities of the eutectic point prediction methods in context of DESs based on machine learning approach.

The most relevant method for eutectic point prediction is COSMO-RS model that allows solid-liquid equilibrium modelling. This approach was applied to limited number of DESs in the literature to predict their eutectic points [2,3]. However, we showed that COSMO-RS model had poor prediction ability related to DESs. An experimental dataset of 117 DESs was used to compare experimental values with predicted ones by COSMO-RS model. Our results showed that COSMO-RS model could predict DES melting point in 72% of cases with low accuracy. One more disadvantage of COSMO-RS model is requirement to know the enthalpy of fusion for each DES compounds. However, only limited number of experimental fusion enthalpy values are presented in the literature.

To solve this problem, we propose melting point prediction algorithm based on machine learning approaches. An experimental dataset of 200 DESs is used to train the model. Thermodynamic properties of the initial compounds, several chemoinformatic descriptors, as well as  $\sigma$ -profile and activity coefficient calculated with COSMO-RS model were used as descriptors to predict the eutectic melting point. To analyze the impact of each descriptor we used linear regression model that allowed us to reduce the descriptors number to 5. Preliminary results obtained by random forest regression model showed good correlation between the predicted and experimental data for melting points ( $R^2 \sim 0.938$ ) (Figure1). Notably, fusion enthalpies of the initial compounds were not used in this prediction.



**Figure 1.** Comparative results of melting point ( $T_m$ ) prediction by COSMO-RS model and machine learning (ML) approach.

Our results showed that COSMO-RS model could predict DES melting point in limited number of cases. Whereas the machine learning approach allowed to predict DES melting point with more accuracy. This approach is also perspective as does not require the knowledge of experimental fusion enthalpy which is difficult of access. Linear regression model allowed us to determine the most impactful descriptors and random forest regression allowed to achieve good correlation between the predicted and experimental data. To improve our model, we are planning to use evolutionary machine learning algorithms and validate our model by experimental approach.

## References

- [1] A. Kovács, E. C. Neyts, I. Cornet, M. Wijnants, P. Billen, *ChemSusChem* **2020**, *13*, 3789.
- [2] Z. Song, J. Wang, K. Sundmacher, *Green Energy Environ.* **2020**.
- [3] D. O. Abranches, M. Larriba, L. P. Silva, M. Melle-Franco, J. F. Palomar, S. P. Pinho, J. A. P. Coutinho, *Fluid Phase Equilib.* **2019**, *497*, 71.
- [4] A. Klamt, in COSMO-RS, *Elsevier*, **2005**, pp. 83–107.

DEEP EUTECTIC SOLVENTS BASED ON CHOLINE CHLORIDE AND POLYOLS  
AS 'GREEN' EXTRACTANT FOR AZEOTROPIC MIXTURES

*Liubichev D.A.<sup>1</sup>, Samarov A.A.<sup>1</sup>, Prikhodko I.V.<sup>1</sup>*

<sup>1</sup>Saint Petersburg State University, Saint Petersburg, Russia  
PhD Student  
[dmitrylyubichev@gmail.com](mailto:dmitrylyubichev@gmail.com)

Nowadays chemistry tries to solve actual environmental problems. Particularly, there is a certain request for an emission of different volatile compounds reduction, creating new sustainable methods of water purification and energy production. In all these cases scientists can reach the solution using deep eutectic solvents too [1]. Deep eutectic solvents (DESs) are mixtures based on donor and acceptor of hydrogen bond. Such interactions cause the much lower melting point of DES comparing with the individual components. In fact, DESs represent a new wide-spreading kind of solvents, it made mostly from quaternary ammonium salts (especially choline chloride) and different HBDs likewise glycerol, urea, and ethylene glycol. Fortunately, developing in this field of searching variety of components state the possibility to construct relevant solvent in exact conditions.

Herein we consider the ability to separate mixtures of alcohols with its acetate esters (ethyl acetate, n-propyl acetate, n-butyl acetate) using choline chloride – 1,2-ethanediol and choline chloride – 1,2-propanediol deep eutectic solvents. Tie-lines were obtained at temperatures 293.15 K and 313.15 K and atmospheric pressure. The compositions of coexisting organic and DES phases are determined by <sup>1</sup>H NMR-spectroscopy. The extraction performance was characterized with distribution coefficients and values of selectivity for used alcohols. NRTL model was applied to correlate LLE in these systems.

#### References

[1] Florindo C., Lima F., Ribeiro B. D., Marrucho I.M. *Curr. Opin. Green Sustain. Chem.*, **2019**, 18, 31-36.

Acknowledgements. This study was supported by the Council on grants of the President of the Russian Federation (grant MK-1288.2020.3). The experimental work was facilitated by the equipment of Magnetic Resonance Research Centre at St. Petersburg State University.

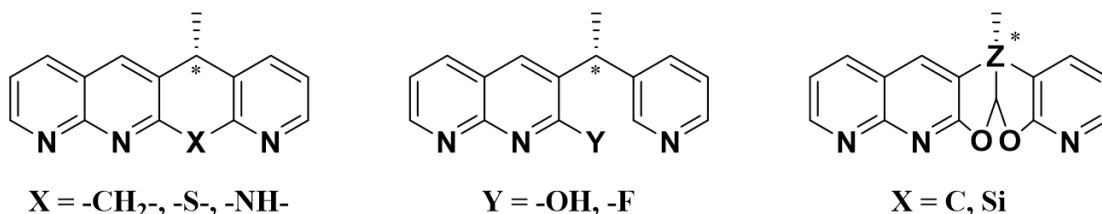
# THEORETICAL DESIGN OF MONOLAYERS ON PLATINUM CATALYSTS SURFACE FOR STEREOSELECTIVE ADSORPTION AND CATALYSIS

*Livshits G.D.,<sup>1</sup> Ignatov S.K.<sup>1</sup>*

<sup>1</sup>Lobachevsky State University, Nizhny Novgorod, Russia  
Student  
[grigory.livshits@gmail.com](mailto:grigory.livshits@gmail.com)

Regioselective hydrogenation of unsaturated carbonyl compounds is one of the most relevant questions in modern manufacturing, especially like fragrance, production of bioactive compounds [1-2]. Unfortunately, in the related industries, e.g. pharmaceutical, regioselectivity could be insufficient: there may be hundreds of stereoisomers of compound, but only one or several have required bioactivity. The main idea of the current work is the design and theoretical verification of functionalizing ligands that would form layer on the platinum surface that would discriminate different stereoisomers of chiral compounds during adsorption.

Seven condensed pyridine derivatives were proposed as orienting ligands. The idea is in strong adsorption by three nitrogen atoms and special 'book' conformation, by which these molecules would form suitable layer on the platinum surface.



**Figure 1.** Studied orienting ligands.

Structures of the considered molecules was optimized by methods PM6, B3LYP/6-31G(d,p), thermodynamic functions of formation were calculated. The (100) platinum surface was modeled by symmetric clusters Pt<sub>36</sub>, Pt<sub>64</sub>, Pt<sub>100</sub>, which corresponded to tetragonal double-layer 6x6, 8x8, 10x10 parts of platinum surface. Structures of clusters were optimized by PM6, BPW91/CRENBS.

Two ligand molecules were placed on the platinum surface, the structure was optimized by PM6. Based on the analysis of the structural and energy characteristics of the complexes, ligand A/S was chosen as the most promising orienting ligand. For it more resource-intensive modeling by BPW91/6-31G(d,p)/CRENBS was carried out.

To simulate the coadsorption two amino acids (proline, alanine) and two unsaturated ketones (pantolactone, 3-methylhex-4-en-2-on C<sub>7</sub>H<sub>12</sub>O) were considered as the latter. Amino acids were proposed because it was found that the interaction energy of various unsaturated ketones with a modified surface is insufficient for their adsorption. Thus, the catalytic reaction with these reagents should slow down significantly.

It was found that the energy of the adsorption complexes of a platinum cluster, a layer of orienting ligands, and an additional molecule is determined by the chirality of this additional molecule. For proline, the adsorption energy of D-isomer varies within 8-23 kcal/mol, depending on the relative position of the OL and the chiral molecule (PM6 calculations). At the same time, the adsorption energy of L-proline is only in the range of 6-13 kcal/mol. The significant difference of adsorption energies demonstrates that the proposed OL structures ensures the effective discrimination of different enantiomers and can be prospective for the development of stereoselective catalysts for the reactions of bifunctional amino derivatives.

## References

- [1] Gombos, R., Nagyházi, B. & Joó, F. Hydrogenation of  $\alpha,\beta$ -unsaturated aldehydes in aqueous media with a water-soluble Pd(II)-sulfosalan complex catalyst. *Reac Kinet Mech Cat.* **2019**, 126, 439–451.
- [2] R. Ghomari, A. Bouferguene, P.E. Hoggan, S.M. Mekelleche, A Density Functional Theory Study of the Adsorption of 2-Cyclohexenone on Rh(111). *Advances in Quantum Chemistry.* **2014**, 68, 175-190.

Acknowledgements. This work was supported by the Russian Foundation for Basic Research (projects No 20-03-00282 and 18-43-520012).

## URACILS ANALOGS AS POTENTIAL ANTI-TUMOR AGENTS

*Martynova Y.Z.<sup>1</sup>, Khayrullina V.R.<sup>1</sup>, Gimadieva A.R.<sup>2</sup>, Mustafin A.G.<sup>1,2</sup>*

<sup>1</sup>Bashkir State University, Ufa, Russia

<sup>2</sup>Ufa Institute of Chemistry of Russian Academy of Sciences, Ufa, Russia

Graduate student

[MartynovaYuZ@gmail.com](mailto:MartynovaYuZ@gmail.com)

A quantitative analysis of relationships between structures of 5-benzyluracils and efficiency of inhibitors deoxyuridine triphosphatase (dUTPase) was made by the program GUSAR 2019 (General Unrestricted Structure Activity Relationships) [1-2]. Biological data from ChEMBL [3] were used for creation of QSAR models. In general 6 statistically significant QSAR-models ( $R^2_{TrS} > 0.6$ ,  $R^2_{TS} > 0.5$ ,  $Q^2 > 0.6$ ) for prediction of  $IC_{50}$  values for various 5-benzyluracils for dUTPase were created based on MNA- and QNA-descriptors, as well as consensus of their combinations. The statistical characteristics of some of the models we constructed are presented in the Table 1. These models can be used for quantitative prediction of potential anti-tumor drugs against dUTPase. Atoms and structural fragments of the studied structures influencing on increase and decrease of dUTPase inhibition were identified by GUSAR 2013 visualization of quantitative “structure-activity” relationships in the created models. The results of structural analysis of the contribution of the different functional groups in the activity of dUTPase inhibition can be considered in the molecular design of active substances of known anticancer drugs in order to enhance the efficiency of their inhibitory action dUTPase. As a result of the virtual screening of the ChEMBL database using consensus models M3 and M6, 10 potential dUTPase inhibitors have been identified.

**Table 1.** Characteristics and prediction accuracy of  $IC_{50}$  values for consensus-models M1-M6.  $pIC_{50}$  activity in TrS1 and TrS2 lies in the range -7.523 – -3.733.

Training set	Models	N	$R^2_{TrS}$	$R^2_{TS}$	F	S.D.	$Q^2$	V
<i>QSAR model based on QNA-descriptors</i>								
TrS1	M1	108	0.932	0.637	13.639	0.439	0.694	15
TrS2	M4	113	0.932	0.701	16.941	0.443	0.691	12
<i>QSAR model based on MNA-descriptors</i>								
TrS1	M2	108	0.950	0.547	11.863	0.390	0.761	20
TrS2	M5	113	0.946	0.706	11.673	0.409	0.740	20
<i>QSAR model based on QNA- and MNA-descriptors</i>								
TrS1	M3	108	0.946	0.576	12.345	0.411	0.735	17
TrS2	M6	113	0.946	0.674	11.110	0.425	0.719	18

N – number of structures in the training set;  $R^2_{TrS}$  - a multiple coefficient of determination calculated for compounds from the training set;  $R^2_{TS}$  - a multiple coefficient of determination calculated for compounds from the test set;  $Q^2$  – a cross-validated  $R^2$  calculated during leave-one-out cross-validation procedure on data of the training set; F – Fisher's coefficient; SD – standard deviation; V- the number of variables in the final regression equation.

### References

- [1] Filimonov D.A. et al. *SAR and QSAR in Environmental Research*, **2009**, 20 (7–8): 679–709.  
 [2] Khayrullina V.R. et al. *Biochemistry (Moscow)*, **2015**, 80 (1): 74–86.  
 [3] ChEMBL: <https://www.ebi.ac.uk/chembl/>.

Acknowledgements. This work was supported by the Russian Science Foundation (project No 19-73-20073)



# THERMAL STABILITY OF NOVEL ENERGETIC 6,8-DINITROTRIAZOLO[1,5-A]PYRIDINES FROM QUANTUM CHEMISTRY AND THERMAL ANALYSIS

*Melnikov I.N.<sup>1</sup>, Kiselev V.G.<sup>1,2</sup>, Dalinger I.L.<sup>3</sup>, Muravyev N.V.<sup>1</sup>, Pivkina A.N.<sup>1</sup>*

<sup>1</sup>N.N. Semenov Federal Research Center for Chemical Physics  
Russian Academy of Sciences, Moscow, Russia

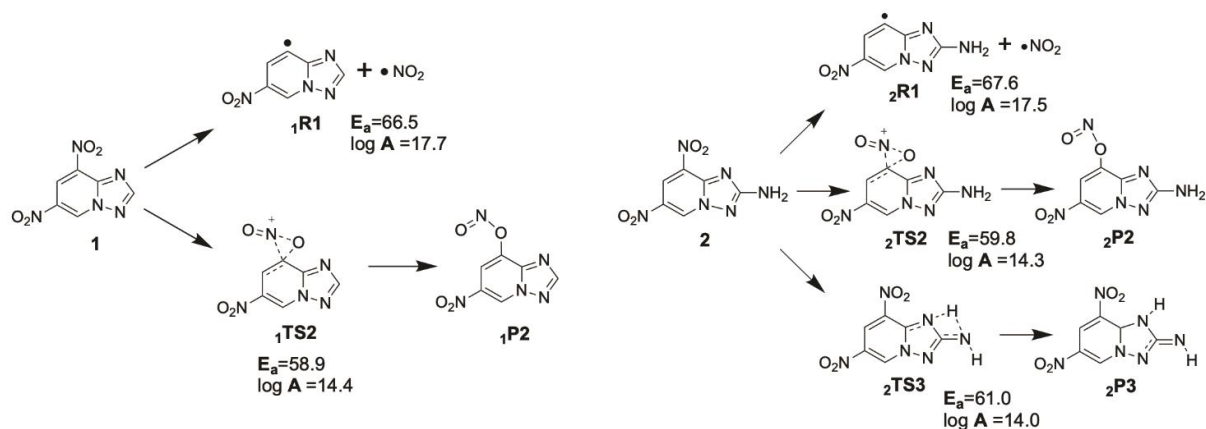
<sup>2</sup>V.V. Voevodsky Institute of Chemical Kinetics and Combustion Siberian Branch  
of the Russian Academy of Sciences, Novosibirsk, Russia

<sup>3</sup>N.D. Zelinsky Institute of Organic Chemistry Russian Academy of Sciences, Moscow, Russia  
Postgraduate student  
[igor.n.melnikov@yandex.ru](mailto:igor.n.melnikov@yandex.ru)

One of the modern trends in the design of energetic materials is synthesis of compounds with improved thermal stability and mechanical sensitivity. Fused heterocyclic structures agree with this demand. Additionally, these compounds often have a high density, which is beneficial for energetic performance. Recently, Starosotnikov et al. [1] reported the synthesis of the series of N-bridged 6,8-dinitrotriazolo[1,5-a]pyridines, including 6,8-dinitro[1,2,4]triazolo[1,5-a]pyridine (**1**) and 6,8-dinitro[1,2,4]triazolo[1,5-a]pyridin-2-amine (**2**). Compounds **1** and **2** show high thermal stability evidenced by thermal decomposition onsets at 281 and 339 °C, respectively. This preliminary characterization is the only information available about their thermal stability. Thus, the motivation of present work is to study the kinetics and mechanism of thermal decomposition of novel compounds **1** and **2**.

Thermal decomposition of **1** and **2** in a condensed phase was studied using differential scanning calorimeter (DSC) at the heating rates of 0.5-10 °C min<sup>-1</sup>. In experiments at atmospheric pressure both compounds vaporize prior to decomposition. Thus, the elevated nitrogen pressure of 2.0 MPa has been applied allowing to suppress the evaporation and to observe the thermal decomposition. Thermokinetic analysis was performed on non-isothermal data using isoconversional and model-fitting techniques.

Thermal decomposition of **1** and **2** was also investigated theoretically using the quantum chemical calculations with the novel high accuracy method DLPNO-CCSD(T)/aug-cc-pVQZ [2]. The considered primary reactions include the radical bond cleavage C-NO<sub>2</sub> (**R1**), nitro-nitrite rearrangement (**TS2**), different hydrogen transfer reactions of <sup>1</sup>**TS2** and <sup>2</sup>**TS2** are the most favorable reaction for both compounds from an energetic point of view (Figure1). However, comparison of the rate constants for molecular and radical channels shows that this conclusion is not true for the full temperature range, and at temperature near 230 °C the radical decomposition channel became to dominate. These results will be discussed in the presentation and compared with the experimental kinetic findings.



**Figure 1.** Competitive reactions in decomposition mechanisms of **1** and **2**. The activation energy values are given in kcal mol<sup>-1</sup> and pre-exponential factors are in s<sup>-1</sup>.

## References

- [1] Starosotnikov A.M., Bastrakov M.A., Knyazev D.A. et al. *Chemistry Select* **2019**, 4, 1510–1515.  
[2] Neese, F. *WIREs Comput. Mol. Sci.* **2018**, 8.

Acknowledgements. This work was supported by the Ministry of Science and Higher Education of the Russian Federation (project #075-15-2020-803 to Zelinsky Institute of Organic Chemistry).

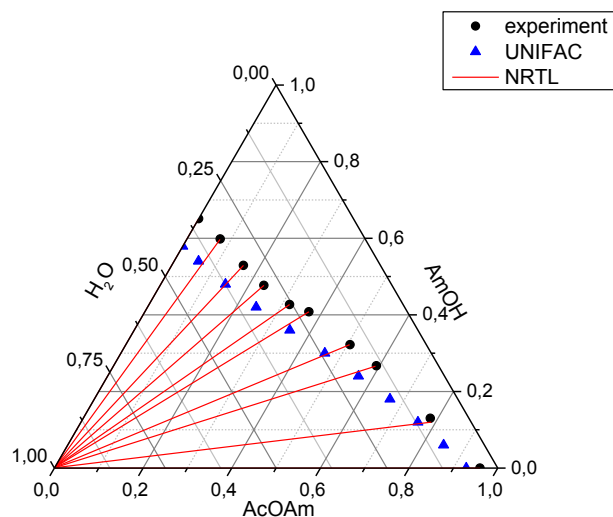
# DESCRIBING OF LIQUID-LIQUID EQUILIBRIUM FOR SYSTEMS WITH POSSIBLE ESTERIFICATION REACTION USING VARIOUS MODEL APPROACHES

*Misikov G.Kh.<sup>1</sup>, Toikka M.A.<sup>1</sup>, Samarov A.A.<sup>1</sup>, Petrov A.V.<sup>1</sup>, Toikka A.M.<sup>1</sup>*

<sup>1</sup>Saint Petersburg State University, Saint Petersburg, Russia  
Student  
[zakgeor@list.ru](mailto:zakgeor@list.ru)

Study of heterogeneous equilibria, especially in multicomponent systems, is a fundamental problem of chemical thermodynamics that nowadays attracts attention of scientist due to its theoretical and practical importance. On the one hand, phase equilibria, and liquid-liquid equilibria in particular, are the theoretical basis for many separation and purification processes, which are closely related to synthesis of various compounds both in laboratory and in industry. For this reason, mixtures containing compounds, that are capable of reacting with each other, are especially interesting. A good demonstrative example of such kind of systems are different mixtures containing acid, alcohol, ester and water, where esterification reaction is possible. Moreover, all the compounds of such systems are important for industrial purposes because they are used as solvents by production of cellulose, plastics etc.

On the other hand, interest to liquid-liquid equilibria in multicomponent systems is bind not only with its experimental study but with the opportunity to describe obtained data and to predict a phenomenon of splitting theoretically as well.



**Figure 1.** Phase diagram for system amyl alcohol – amyl acetate – water at 20 °C: ● – experiment, ▲ – UNIFAC, – – NRTL.

The object of our study are different quaternary systems acetic/propionic acid + alcohol (butanol/pentanol/hexanol) + corresponding ester + water [1-6]. In this work, some approaches for modeling liquid-liquid equilibria (UNIFAC, NRTL) were observed and compared in relation to investigated mixtures. An attempt to apply method of artificial neural network for describing liquid-liquid equilibria in ternary and quaternary systems was made as well.

## References

- [1] Trofimova M.A., Misikov G.Kh., Samarov A.A., Prikhodko I.V., Toikka M.A. *Journal of Chemical Thermodynamics* **2021**, *161*, 106515.
- [2] Toikka M.A., Vernadskaya V., Samarov A.A. *Fluid Phase Equilibria* **2018**, *471*, 68–73.
- [3] Trofimova M.A., Toikka M.A., Toikka A.M. *Fluid Phase Equilibria* **2012**, *313*, 46-51.
- [4] Toikka M.A., Samarov A.A., Toikka A.M. *Fluid Phase Equilibria* **2014**, *375*, 66–72.
- [5] Samarov A.A., Toikka M.A., Toikka A.M. *Fluid Phase Equilibria* **2015**, *385*, 129–133.
- [6] Reynel-Avila H.E., Bonilla-Petriciolet A., Tapia-Picazo J.C. *Fluid Phase Equilibria* **2019**, *483*, 153–164.

Acknowledgements. The calculation of the compositions of liquid-liquid equilibrium using the models (UNIFAC and NRTL) and experimental results were carried out with financial support from the Russian Science Foundation (project No 20-73-10007). Application of the method of artificial neural networks to describe liquid-liquid equilibria was supported by the Russian Foundation for Basic Research (project No 19-03-00375 A).

THEORETICAL EVALUATION OF NEW PROMISING SOLID ION CONDUCTORS  
FOR MULTIVALENT METAL-ION BATTERIES

*Morkhova E.A.*<sup>1,2,3</sup>, *Kabanov A.A.*<sup>1,3,4</sup>, *Leisegang T.*<sup>1,5</sup>, *Blatov V.A.*<sup>1,2</sup>

<sup>1</sup>Samara Center for Theoretical Materials Science, Samara State Technical University, Samara, Russia

<sup>2</sup>Samara Center for Theoretical Materials Science, Samara University, Samara, Russia

<sup>3</sup>Institute of Solid State Chemistry and Mechanochemistry SB RAS, Novosibirsk, Russia

<sup>4</sup>P. N. Lebedev Physical Institute of the Russian Academy of Sciences, Samara, Russia

<sup>5</sup>Institute of Experimental Physics, Energy Materials, TU Bergakademie Freiberg, Freiberg, Germany

[eliztimofeeva@mail.ru](mailto:eliztimofeeva@mail.ru)

The current trend in battery materials science is the search for new ionic conductors, which can replace lithium materials in ion batteries because of depletion of lithium resources, ecological and political issues [1]. A possible solution is multivalent metal-ion batteries, fuel cells or gas sensors. The multivalent metal-ion batteries have many advantages, such as abundance and low cost of raw materials and a higher theoretical capacity compared to lithium-ion batteries, higher safety and reduced environmental impact, which attracted the significant interest to multivalent ion batteries in the last decade [2].

We have applied a combined stepwise theoretical approach to search for solids with high ionic conductivity of multivalent working ions (WI) among ternary and quaternary Mg<sup>2+</sup>, Ca<sup>2+</sup>, Sr<sup>2+</sup>, Zn<sup>2+</sup> or Al<sup>3+</sup> oxides and chalcogenides. The search procedure has included high-throughput screening of the Inorganic Crystal Structure Database (ICSD) based on geometrical-topological analysis, bond valence site energy calculations, simulation of ionic conductivity by using the kinetic Monte Carlo method and quantum-chemical simulation of ion transport within the Density Functional Theory. As a result, we have found 52 promising potential Mg<sup>2+</sup>, Ca<sup>2+</sup>, Sr<sup>2+</sup>, Zn<sup>2+</sup>, or Al<sup>3+</sup> ion conductors (Table 1).

**Table 1.** The number of new promising ternary and quaternary cationic conductors with various compositions.

WI-environment	Total number of structures in ICSD	Total number of selected ion conductors	The most promising structures with values of migration energies ( $E_m$ , eV) of WI
Mg-O	2778	8	Mg <sub>3</sub> Nb <sub>6</sub> O <sub>11</sub> (0.41 eV), Mg <sub>3</sub> V <sub>2</sub> (SiO <sub>4</sub> ) <sub>3</sub> (0.90 eV), MgGeO <sub>3</sub> (0.91 eV) [3]
Mg-S,Se,Te	111	3	MgM <sub>2</sub> Se <sub>4</sub> (M=Ho (0.46 eV), Er (0.45 eV), Tm (0.42 eV), Yb (0.50 eV), Lu (0.38 eV)), MgLa <sub>3</sub> AlS <sub>7</sub> (0.71 eV)
Ca-O	4171	4	CaNb <sub>2</sub> O <sub>4</sub> (0.44 eV) [3]
Sr-O	2234	7	SrCr <sub>2</sub> O <sub>4</sub> (1.69 eV) [3]
Zn-O	782	9	ZnM <sub>2</sub> O <sub>4</sub> (M=V (0.55 eV), Fe (0.54 eV), Cr (0.70 eV)), ZnP <sub>2</sub> O <sub>6</sub> (0.68 eV) [4]
Zn-S,Se,Te	778	11	ZnM <sub>2</sub> Se <sub>4</sub> (M=Al (0.88 eV), Yb (0.81 eV)), ZnCaOS (0.86 eV)
Al-O	4346	3	AlFe <sub>2</sub> O <sub>4</sub> (1.00 eV), AlVO <sub>3</sub> (1.02 eV) [5]
Al-S,Se,Te	416	7	Al <sub>0.33</sub> Sm <sub>3</sub> Si <sub>7</sub> (0.60 eV), Al <sub>5.9</sub> SnTe <sub>9.892</sub> (0.99 eV)

### References

- [1] Leisegang T., Meutzner F., Zschornak M., Münchgesang W., Schmid R., Nestler T., Meyer D.C. 2019 *Frontiers in chemistry*. **2019**, *4*, 268.
- [2] Tang H., Peng Z., Wu L., Xiong F., Pei C., An Q., Mai L. *Electrochemical Energy Reviews*. **2018**, *1*(2), 169-199.
- [3] Morkhova E.A., Kabanov A.A., Blatov, V.A. *Russian Journal of Electrochemistry*. **2019**, *55*(8), 762-777.
- [4] Morkhova E., Rothenberger M., Leisegang T., Adams S., Blatov V., Kabanov A. *submitted to The Journal of Physical Chemistry C*. **2021**.
- [5] Nestler T., Meutzner F., Kabanov A.A., Zschornak M., Leisegang T., Meyer D.C. *Chemistry of Materials*. **2019**, *31*(3), 737-747.

**Acknowledgements.** This work was supported by the Russian Science Foundation (project No 19-73-10026), Russian Foundation for Basic Research (project No 20-33-90018) and the German Federal Ministry of Education and Research (R2RBattery: 03SF0542A).

## EFFECT OF IONIC LIQUID ADDITION IN THE ELECTROLYTE ON SOLVATION PROCESSES IN LITHIUM-AIR BATTERIES

*Pavlov S.V.*<sup>1,2</sup>, *Danilova V.V.*<sup>3</sup>, *Fedorov M.V.*<sup>1</sup>, *Kislenko S.A.*<sup>2,3</sup>

<sup>1</sup>Skolkovo Institute of Science and Technology, Moscow, Russia

<sup>2</sup>Joint Institute for High Temperatures of the RAS, Moscow, Russia

<sup>3</sup>Moscow Institute of Physics and Technology, Moscow, Russia

Ph.D. Student

[sergey.v.pavlov@phystech.edu](mailto:sergey.v.pavlov@phystech.edu)

This work is devoted to the study of solvation processes in the lithium-air batteries. These devices are considered a promising alternative to commercially successful lithium-ion batteries due to their high theoretical specific capacity. Because of the complexity of the oxygen reduction reaction mechanism and occurring side processes, particularly connected with the electrode and electrolyte degradation, optimization of lithium-air batteries is highly complicated. Thus, the directional design of electrode materials, electrolytes, and catalysts is an urgent scientific problem, which can be solved including with the help of computer simulations [1, 2].

In this work, we have studied the effect of an ionic liquid on the structure and stability of solvation shells around a number of ions participating in both the oxygen reduction reaction and parasitic processes. Ionic liquids are organic salts that are liquid at room temperature and possess a set of unique properties: non-volatility, high oxygen solubility, non-flammability, and high stability, which make them promising as electrolytes for various electrochemical systems [3], in particular for lithium-air batteries [4].

We obtained the structural characteristics of the solvation shells of ions: Li<sup>+</sup>, O<sub>2</sub><sup>-</sup>, O<sub>2</sub><sup>2-</sup>, CO<sub>3</sub><sup>2-</sup> in an electrolyte based on dimethoxyethane (DME) containing different amounts of the ionic liquid PYR14TFSI. This ionic liquid was chosen as the most studied experimentally in the context of lithium-air batteries [4]. The potentials of mean force (PMF) of Li<sup>+</sup> and O<sub>2</sub><sup>-</sup> ions in electrolytes with different amount of the ionic liquid was calculated, which allow characterizing the kinetics of Li<sup>+</sup> and O<sub>2</sub><sup>-</sup> association reaction, which is one of the clue stages of the oxygen reduction reaction, and directly affects its mechanism.

### References

- [1] Pavlov S.V., Kislenko S.A. *Phys. Chem. Chem. Phys.* **2016**, 18, 30830-30836.
- [2] Smirnov V.S., Kislenko S.A. *Chem. Phys. Chem.*, **2018**, 19, 75-81.
- [3] Fedorov M.V., Kornyshev A.A. *Chem. Rev.*, **2014**, 114, 2978-3036.
- [4] Xie J. et al. *Nano Letters*, **2015**, 15, 8371-8376.

Acknowledgements. This work was supported by the Russian Foundation for Basic Research (project No 20-33-90218).

## CONJUGATED QUANTITATIVE STRUCTURE-PROPERTY RELATIONSHIP MODELS

Rakhimbekova A.<sup>1</sup>, Zankov D.V.<sup>1</sup>, Nugmanov R.I.<sup>1</sup>, Madzhidov T.I.<sup>1</sup>, Baskin I.I.<sup>1,2</sup>, Varnek A.A.<sup>3</sup>

<sup>1</sup>Kazan Federal University, Kazan, Russia

<sup>2</sup>Technion - Israel Institute of Technology, Haifa, Israel

<sup>3</sup>University of Strasbourg, Strasbourg, France

PhD Student

[asima.rakhimbekova@outlook.com](mailto:asima.rakhimbekova@outlook.com)

We proposed and developed a concept of conjugated Quantitative Structure-Property Relationship (QSPR) models for the simultaneous prediction of several properties linked by strict mathematical relationships. The developed conjugated models were applied to the modeling:

(1) the logarithm of the prototropic tautomeric constant, which can be expressed as the difference between the acidity constants of two related tautomers [1];

(2) the reaction rate constant, pre-exponential factor, and activation energy which are related by the Arrhenius equation;

(3) the selectivity constant, which can be expressed as the ratio of two competing reaction rate constants.

These mathematical relations are integrated analytically into the ridge regression algorithm.

The developed conjugated QSPR models have some practically beneficial properties that classical QSPR models do not have. In the case of tautomerism reactions, the proposed approach makes it possible to simultaneously predict the equilibrium constant of tautomerism and acidity of tautomers. Moreover, the conjugated models can predict acidity for major and minor tautomers [1]. In the case of the reactions occurring through the competing mechanisms of bimolecular elimination and bimolecular nucleophilic substitution reactions, the developed conjugated QSPR models simultaneously predict the fraction of one of the products and the rate constant of competing reactions. Finally, the conjugated approach based on the Arrhenius equation allows us to build a model for predicting the activation energy without using direct experimental data on it during training models.

### References

[1] Zankov D.V., Madzhidov T.I., Rakhimbekova A., Gimadiev T.R., Nugmanov R.I., Kazymova M.A., Baskin I.I., Varnek A. *J. Chem. Inf. Model.* **2019**, *59*, 4569–4576.

Acknowledgements. This work was supported by the Russian Science Foundation (project № 19-73-10137).

## ML-ASSISTED PREDICTION OF ENZYME-MIMIKING NANOMATERIALS

*Razlivina J.S.,<sup>1</sup> Serov N.S.,<sup>1</sup> Vinogradov V.V.<sup>1</sup>*

<sup>1</sup>ITMO University, Saint Petersburg, Russia

Student

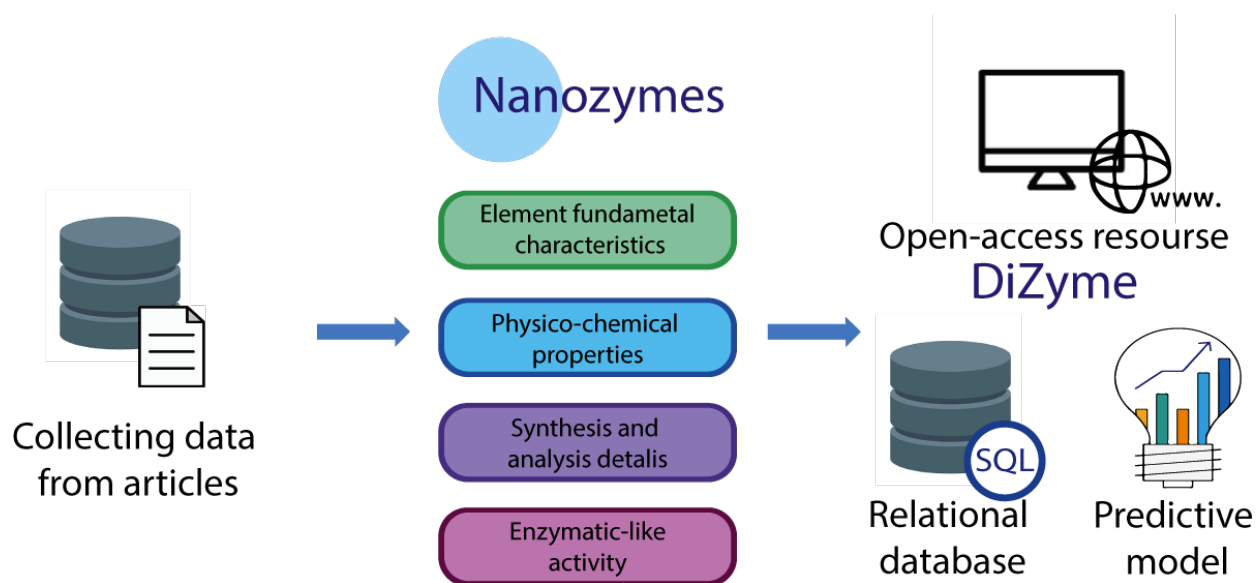
[razlivina@scamt-itmo.ru](mailto:razlivina@scamt-itmo.ru)

Nanozymes are nanomaterials with enzyme-like characteristics. Nanozymes were discovered as a way to eliminate the disadvantages of natural enzymes, such as high cost, low stability and difficulty of storage. They have proven themselves in biosensors, cancer theranostics, and environmental protection. Today there are various types of nanozymes that have been discovered by trial-and-error strategy.

The enzymatic activity of nanozymes depends on the fundamental characteristics of the element, its shape, size, porosity, etc., as well as the conditions of analysis. These dependencies are difficult to discover using theoretical approaches, for which we use machine learning methods.

In this work, we used metal oxide and metal-based nanozymes, because after reviewing a lot of literature, we saw that this class is often used in articles and it is not complicated in terms of synthesis, and the moiety built on their basis can be easily extended to other types of nanozymes.

We assembled a database of 200 samples based on existing articles on nanozymes. Our database contains predictors and response. The predictor is the independent variable of the predictor. In this work, we use four groups of predictors: element constants, physical material properties, synthesis and analysis details. The response is the dependent variable predicted by the model. The response is the enzymatic activity, which will be predicted quantitatively, namely the Michaelis constant ( $K_m$ ).



**Figure 1.** Concept.

Missing data in the features were filled in using the k-nearest neighbor method, with 80% of the data available. We chose a random forest regression model as our machine learning model, which is capable of analyzing a large amount of nonlinear data. The model showed an accuracy of 0,7. An open platform DiZyme with a built-in replenishable database with a visualizer and predictive model was created. With its help, scientists will be able to predict the enzyme-like activity of the particles they need.

# EFFECT OF EXTERNAL ELECTRIC FIELD ON THE DIFFUSION OF OXYGEN IONS AND VACANCIES IN YTTRIA-STABILIZED ZIRCONIA. MOLECULAR DYNAMICS STUDY

*Rozhkov A.V.<sup>1</sup>, Ignatov S.K.<sup>1</sup>, Suleimanov E.V.<sup>1</sup>*

<sup>1</sup>Chemistry Department, N.I. Lobachevsky State University of Nizhny Novgorod, Nizhny Novgorod, Russia  
PhD Student  
[a190064@chem.unn.ru](mailto:a190064@chem.unn.ru)

One of the promising areas of modern energy technologies is the development of fuel cells, among which solid oxide fuel cells (SOFCs) occupy a special place. Their advantages are the absence of expensive catalysts in the design, resistance to carbon monoxide poisoning, the ability to use with various types of fuels with high efficiency, as well as low product toxicity [1]. The main efforts to improve SOFCs are currently aimed at reducing their high operating temperature (700-1000°C), which is required to increase the mobility of O<sup>2-</sup> ions in a solid electrolyte.

Yttria-stabilized zirconia (YSZ) is one of the most commonly used solid electrolytes utilized in SOFC production due to its high ionic conductivity and stability in oxidation and reduction reactions. The influence of composition and temperature on the diffusion of oxygen ions in YSZ has been studied in detail experimentally [2,3] and theoretically [3,4], but another important factor – the external electric field – has been completely ignored in previous studies. In this work, we study the mobility of charge carriers in YSZ and its dependence on the external electric field by the method of classical molecular dynamics.

The model system was a 5x5x5 cubic supercell of crystalline ZrO<sub>2</sub> oxide doped with Y<sub>2</sub>O<sub>3</sub> with three-dimensional periodic conditions imposed. The number of Y<sup>3+</sup> ions varied in various computer experiments from 30 to 136. For every two Y<sup>3+</sup> ions, one oxygen vacancy was created in the crystal lattice, which is necessary to maintain electroneutrality. Modeling was carried out using the LAMMPS program and the interaction between the oxygen and metal atoms of the doped oxide was described by the sum of the classical pair potential of Buckingham and the Coulomb potential. The parameter set was taken from the study [5], where it was successfully applied for the atomic interaction simulation in YSZ. The total simulation time was up to 2 ns, with an integration step of 0.1 fs. To ensure thermodynamic equilibration, the initial 100 ps trajectory fragment was not taken into account in calculating the diffusion parameters.

It was found that in the temperature range 873-1273 K, the crystal with a 3% molar fraction of yttrium oxide has the highest ionic conductivity, which is consistent with the experiment [2]. The activation energy of the diffusion of O<sup>2-</sup> ions increases with an increase in the Y<sub>2</sub>O<sub>3</sub> content, from 0.45 eV at 4.6 mol.% to 0.61 eV at 15.7 mol%, which is consistent with the data obtained by other theoretical methods (0.2-0.9 eV).

It is shown that the application of an electric field forces the O<sup>2-</sup> ions to diffuse against the direction of the electric field vector, which leads to a significant increase in the MSD of the ions and vacancies relative to the initial position, and, consequently, an increase in the O<sup>2-</sup> diffusion coefficient from  $1.7 \times 10^{-11}$  m<sup>2</sup>/s in the absence of a field to  $5.2 \times 10^{-11}$  m<sup>2</sup>/s at a field strength of 0.02 V/Å. The vacancy diffusion coefficient increases from  $1.4 \times 10^{-9}$  m<sup>2</sup>/s to  $3.42 \times 10^{-8}$  m<sup>2</sup>/s under the same conditions. The activation energy upon application of an electric field decreases at a Y<sub>2</sub>O<sub>3</sub> content of 4.6 mol% and a temperature of 1073 K from 0.45 eV in the absence of a field to 0.32 eV at a field strength of 0.08 V/Å. The applied electric field is potentially capable of lowering the diffusion activation energy and, thus, improving the characteristics of SOFCs by decreasing their operating temperature. Thus, for a 1 mm thick dielectric layer, the imposed potential of 200 kV can be equivalent to a 250 K temperature increase. However, in the case of a static field, a severe decrease in the operating temperature requires an extremely high strength value which is unrealistic with a standard SOFC design.

## References

- [1] Zhou X.-D., Singhal S.C. Encyclopedia of Electrochemical Power Sources, Elsevier, **2009**, 1-16.
- [2] Weller M. et al. *Solid State Ionics*, **2004**, *175*, 409-413.
- [3] Kilo M., Argiris C., Borchardt G., Jackson R.A. *Phys. Chem. Chem. Phys.*, **2003**, *5*, 2219-2224.
- [4] Devanathan R., Weber W.J., Singhal S.C., Gale J.D. *Solid State Ionics*, **2006**, *177*, 1251–1258.
- [5] Gunn D.S.D., Allan N.A., Purton J.A. *J. Mater. Chem. A*, **2014**, *2*, 13407-13414.

Acknowledgments. This work was supported by the Russian Foundation for Basic Research (projects №18-43-520012, №20-03-00282).

# QUANTUM-CHEMICAL MODELING OF ELEMENTARY ACTS OF THE PROCESS OF CYCLOPROPANATION OF FULLERENE BY HALOGENMETHYLKETONES

*Sattarova A.F.*<sup>1,2</sup>, *Biglova Yu.N.*<sup>1</sup>, *Mustafin A.G.*<sup>1,2</sup>

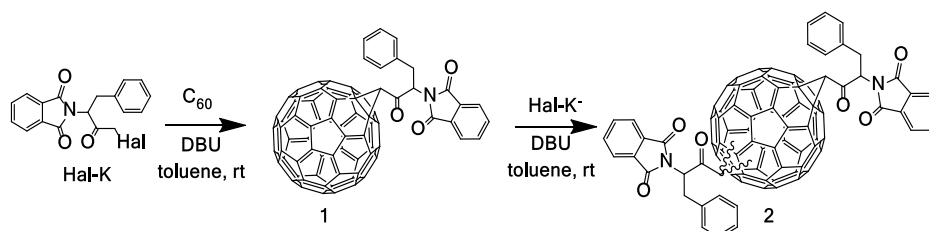
<sup>1</sup>Bashkir State University, Ufa, Russia

<sup>2</sup>Institute of Organic Chemistry Ufa Scientific Centre of Russian Academy of Sciences, Ufa, Russia

PhD Student

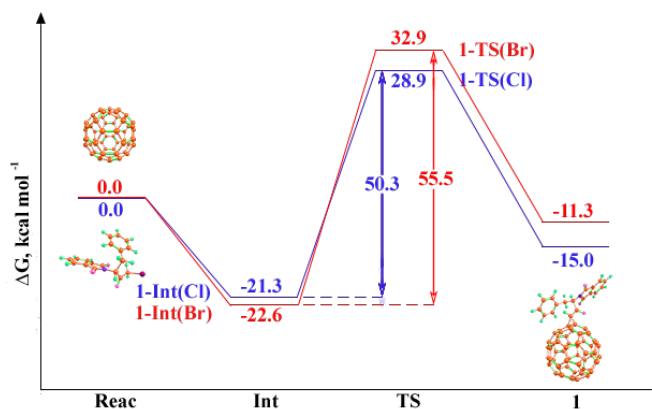
[brux1995@mail.ru](mailto:brux1995@mail.ru)

Thanks to theoretical research, an integrated approach is being implemented in the study of complex, multi-stage processes. For example, for the Bingel reaction [1], all participants in the process were optimized according to the first stage and the modeling of elementary acts was carried out. Quantum-chemical calculations were carried out at the theoretical level B3LYP/6-31G(d) using the example of the reaction of addition of halomethylketones (Cl-K and Br-K) to fullerene (Figure 1), as a model.



**Figure 1.** Synthesis and chemical structures of the mono-adduct 2-{1-benzyl-2-[cyclopropane[1f, 2f] [60] fullerene]-2-hydroxyethyl}-1H-isoindole-1,3 (2H) -dione (**1**) and bis-adduct 2,2'-[bicyclopropano [60] fullerene bis(1-oxy-3-phenylpropane-1,2-diyl)] bis(1H-isoindole-1,3(2H)-dione) (**2**).

The results of the DFT study for the first stage are displayed in Figure 2. Some overestimation of the theoretically found activation energy should be attributed to the imperfection of the basis set.



**Figure 2.** Energy profile of the first stage of fullerene cyclopropanation with chloromethylketone (blue) and bromomethylketone (red).

As seen in Figure 2, the activation energy in the case of bromomethylketone is 5 kcal×mol<sup>-1</sup> higher than that with chloromethylketone. In general, the reaction takes place under kinetic control. The considered interaction is accompanied by the formation of nine regioisomers of di-addition **2**, which were studied at the same theoretical level. It was found that the most thermodynamically stable and, accordingly, predominantly formed in the course of the reaction are the equatorial (*e'*, *e''*) and *trans*-3 isomers. The calculation results agree with the experimentally established regularities [2].

## References

[1] Bingel C. *Chem. Ber.* **1993**, *126*, 1957–1959.

[2] Djojo F., Herzog A., Lamparth I., Hampel F., Hirsch A. *Chem. Eur. J.* **1996**, *2*, 1537–1547.

Acknowledgements. This work was supported by Ministry of Science and Higher Education of the Russian Federation (as part of State task No AAAA-A19-119020890014-7) and Russian Foundation for Basic Research (project No 20-33-90242\20).



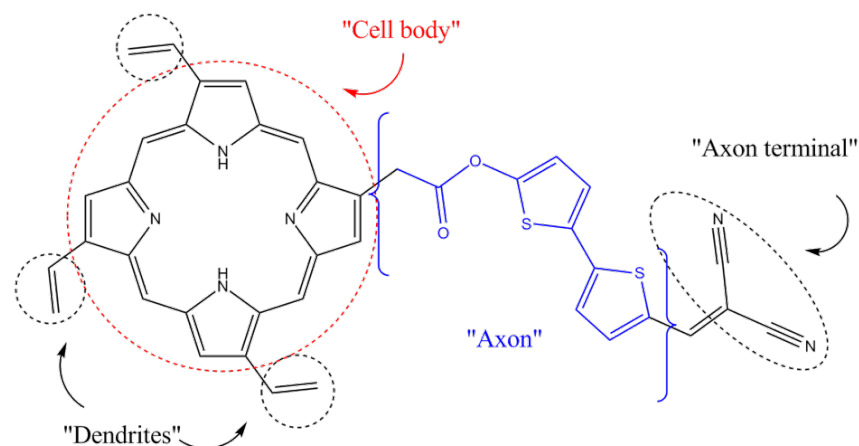
# CHARGE TRANSFER SIMULATION IN BIOMIMETIC OLIGOMERS FOR THE CREATION OF NEUROMORPHIC ORGANIC MATERIALS

*Savintseva L.A.<sup>1</sup>, Ignatov S.K.<sup>1</sup>*

<sup>1</sup>N.I. Lobachevsky State University of Nizhny Novgorod, Nizhny Novgorod, Russia  
PhD Student  
[savintsevaliana@yandex.ru](mailto:savintsevaliana@yandex.ru)

It is a known fact that animals brain works by transferring information between great amount of neurons via electrochemical impulses. Here the question arises about the possibility of creating an artificial material in which charge transport between molecules would reproduce the signal transmission in the neural network and, therefore, would reproduce the behavior of the network of neurons at the molecular level. Such material, if it was considered as a computing system (artificial neural network, ANN), would allow achieving a high density of computational elements, their three-dimensional organization and high computational efficiency.

To function as an ANN, the molecules of such material (referred hereafter as a neuromorphic material) must have the following properties: (i) high ability to intermolecular charge transfer; (ii) a certain function of the "summation" of signals from different sources; (iii) the ability to adapt the positions of intermolecular contacts to react to the most important signals. The search for materials capable to appear neuromorphic properties is the main goal of this study. Because the molecules involved in electron transfer processes are known in nature, we consider here known organic semiconductors belonging to the class of dicyanovinyloligothiophenes, as well as a number of biomimetic structures, which are derivatives of porphyrins and quinones, as components of the charge carrier chain. In this work, the simulation of charge transfer in amorphous materials consisting of oligomers of these molecules is conducted.



**Figure 1.** Possible structure of neuromorphic material molecules by analogy with the structure of a neuron.

For this purpose, the geometric and electronic structure of the molecules under consideration was calculated by the DFT method at the B3LYP/6-31G(d,p) level. The OPLS-AA force field parameterization for oligomers was carried out on the basis of quantum-chemical calculations. Then, the packing of the amorphous material consisting of these oligomers was simulated by the molecular dynamics method in the GROMACS program. In the obtained fragment of the material, the parameters of the electron transfer were calculated in the software package VOTCA. Electronic coupling elements were evaluated by the semi-empirical ZINDO method and the charge dynamics simulation was finally conducted using the kinetic Monte Carlo method.

On the basis of the results obtained the structures of monomers, which can be the most promising from the point of view of charge transfer, have been established. In the simulated materials, paired coupling elements and transfer rates are calculated for each pair of molecules; the mobility of charge carriers and the trajectory of charge transfer are estimated. It was concluded that hole transport predominates in most modeled material fragments.

Acknowledgements. This work was supported by the Russian Foundation for Basic Research (projects No 20-03-00282, 18-43-520012).

# THE CALCULATION OF THERMODYNAMIC EQUILIBRIUM CONSTANTS OF SYSTEMS FORMED BY ACETIC ACID ESTERS USING THE UNIFAC MODEL

*Senina A.A.<sup>1</sup>, Toikka M.A.<sup>1</sup>, Samarov A.A.<sup>1</sup>*

<sup>1</sup>Saint Petersburg State University, Saint Petersburg, Russia  
Student  
[alinasenina77@gmail.com](mailto:alinasenina77@gmail.com)

Nowadays, acetic acid esters (acetates), such as propyl acetate, butyl acetate, and amyl acetate, play an important role in various industries. They are widely used as flavorings in the perfume and food industries, and are also solvents of many organic compounds [1]. Moreover, recent studies have shown that the addition of acetates to biodiesel improves its operational and environmental properties, which means that it is necessary to modernize the technology of biodiesel production, which includes the processes of synthesis and purification of esters [2].

The effective design of the esterification reaction, as well as the separation processes, requires a quantitative description of the phase and chemical equilibria. Experimental information about the properties of many systems is limited due to the large variety of existing organic compounds. In this regard, local composition models were developed to describe the physical and chemical properties of various systems using a small number of parameters. One of the most popular models is the Universal Functional Activity Coefficient or UNIFAC. This model allows us to calculate the excess Gibbs energy and activity coefficients based on the concept of group contribution. The basic equation of this model includes the combinatorial component (the difference in the shapes and sizes of molecules) and the residual component (the difference in the energies of intermolecular interactions) (Figure 1).

This work is devoted to the study of the chemical equilibrium of systems with the reaction of esterification of acetates: propyl acetate, butyl acetate, amyl acetate at 45°C. The activity coefficients of the components of the reaction systems were calculated using the UNIFAC model. Based on the obtained data, the system component activities and the thermodynamic equilibrium constants were calculated, and the thermodynamic and concentration constants were compared.

$$\ln \gamma_i = \ln \gamma_i^{Comb} + \ln \gamma_i^{Res}$$
$$\ln \gamma_i^C = \ln \frac{\varphi_i}{x_i} + \frac{z}{2} q_i \ln \frac{\theta_i}{\varphi_i} + L_i - \frac{\varphi_i}{x_i} \sum_{j=1}^n x_j L_j$$
$$\ln \gamma_i^R = \sum_k^n \left[ \ln \Gamma_k - \ln \Gamma_k^{(i)} \right]$$

**Figure 1.** UNIFAC equations.

## References

- [1] Shibasaki-Kitakawa N. *Roadmaps of Japan: Future Energy Systems Based on Feasible Technologies beyond 2030 (Book Chapter)*. **2016**, 463-468.
- [2] Sami Ali, et al. *Bioresource Technol.* **2011**, 102 (21).

Acknowledgements. This work was supported by the Russian Science Foundation (project No 21-13-00038).

ELECTRONIC STRUCTURE, STABILITY, SODIUM DIFFUSION AND EXTRACTION  
IN LOW-SYMMETRY IONIC CONDUCTORS  $\text{NaMFe}(\text{MoO}_4)_3$  (M=Mg, Ni)

*Serdtssev A.V.<sup>1</sup>, Medvedeva N.I.<sup>1</sup>*

<sup>1</sup>Institute Solid State Chemistry RAS (Ural Division), Ekaterinburg, Russia  
Young Scientist  
[alexander.serdtssev@urfu.ru](mailto:alexander.serdtssev@urfu.ru)

Rechargeable sodium-ion batteries attract significant attention due to their good electrochemical properties and the high availability of low-cost sodium materials. Currently, intensive studies are devoted to the search for new electrolyte and cathode materials with fast sodium diffusion, high voltage, and long charging/discharging cycles as a cheaper alternative to replace lithium-ion batteries [1–3]. Recently, low-symmetry molybdates isostructural to  $\alpha\text{-NaFe}_2(\text{MoO}_4)_3$  and  $\beta\text{-NaFe}_2(\text{MoO}_4)_3$  were proposed as perspective ionic conductors.  $\text{NaMgFe}(\text{MoO}_4)_3$  (isostructural to  $\alpha\text{-NaFe}_2(\text{MoO}_4)_3$ ) and  $\text{NaNiFe}(\text{MoO}_4)_3$  (isostructural to  $\beta\text{-NaFe}_2(\text{MoO}_4)_3$ ) have structural channels filled with sodium atoms. Both compounds have the same chemical composition and mixed occupancy of [M/Fe] (M = Mg, Ni) site as NASICON molybdates, and belong to space group P-1 (Z=2).

We present the results of first-principles simulation of the electronic structure, stability, sodium diffusion and (de)intercalation mechanism in  $\text{NaMgFe}(\text{MoO}_4)_3$  (isostructural to  $\alpha\text{-NaFe}_2(\text{MoO}_4)_3$ ) and  $\text{NaNiFe}(\text{MoO}_4)_3$  (isostructural to  $\beta\text{-NaFe}_2(\text{MoO}_4)_3$ ). All calculations were performed in the Vienna *Ab-initio* Simulation Package (VASP) [4,5]. Using the GGA+U approach, we studied arrangement of [M/Fe] atoms and stability of these compounds, as well as performed comparison with the similar NASICON-type molybdates. Most possible [M/Fe] arrangements and stable phases were predicted. The electronic structure was calculated for possible phases using GGA and GGA+U, and a strong dependence of the band gap on the value of U was established. We calculated barriers for all sodium pathways in  $\alpha\text{-NaFe}_2(\text{MoO}_4)_3$  and  $\beta\text{-NaFe}_2(\text{MoO}_4)_3$  structures and found that they are slightly higher than in the corresponding NASICON phases (~1 eV).

Our results demonstrate that low-symmetry molybdates  $\text{NaMgFe}(\text{MoO}_4)_3$  and  $\text{NaNiFe}(\text{MoO}_4)_3$  have diffusion and redox properties similar to the known NASICON-type compounds, and can also be promising cathode materials for sodium-ion batteries.

#### References

- [1] Chen L., Fiore M., Wang J.E., et al. *Adv. Sustain. Syst.* **2018**, 2, 1700153.
- [2] Watanabe E., Chung S.C., Nishimura S.I., et al. *Chem. Rec.* **2019**, 19, 792–798.
- [3] Skundin A.M., Kulova T.L., Yaroslavtsev A.B. *Russ. J. Electrochem.* **2018**, 54, 113–152.
- [4] Kresse G., Hafner J. *Phys. Rev. B* **1994**, 49, 14251–14269.
- [5] Kresse G., Furthmüller J. *Comput. Mater. Sci.* **1996**, 6, 15–50.

Acknowledgements. This work was supported by the Russian Science Foundation (project No 18-12-00395).

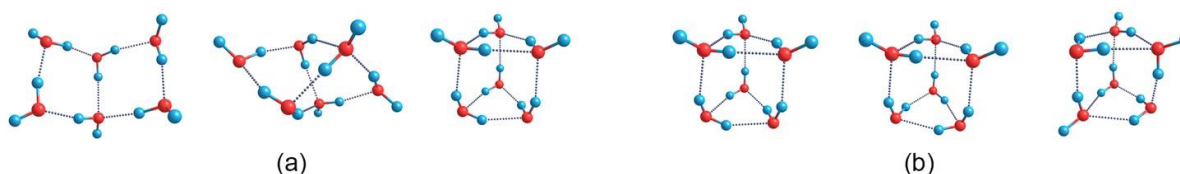
# WATER CLUSTERS (H<sub>2</sub>O)<sub>n</sub> (n = 2–6) IN GAS PHASE: AN EFFECT OF ORIENTATIONAL ISOMERISM ON THEIR THERMODYNAMIC FUNCTIONS AND CONCENTRATIONS

*Shirokova E.A.<sup>1</sup>, Razuvaev A.G.<sup>1</sup>, Ignatov S.K.<sup>1</sup>*

<sup>1</sup>Lobachevsky State University of Nizhny Novgorod, Nizhny Novgorod, Russia  
Ph. D. student  
[ekashirokova@gmail.com](mailto:ekashirokova@gmail.com)

The increased interest in water clusters is caused by their role in a number of important atmospheric properties and processes. As a result, the multimolecular complexes of water, which are found everywhere in the Earth's atmosphere, make a significant contribution to the climate formation and change [1–4].

(H<sub>2</sub>O)<sub>n</sub> clusters are formed due to the combination of n water molecules with hydrogen bonds. For the same n, two types of isomerism can be formed: (1) the isomerism of the oxygen “skeleton” (that is the structure formed by oxygen atoms) and (2) the isomerism of the hydrogen bond network for the same skeleton, which is due to the fact that the formation of the most favorable hydrogen bond in a cluster obeys the rules similar to the Bernal–Fowler rules for an ice crystal. Two types of isomerism are shown in Figure 1, which demonstrates some isomeric structures of the (H<sub>2</sub>O)<sub>6</sub> cluster, which differ in the oxygen skeleton (Figure 1a) and the network of hydrogen bonds for the same oxygen skeleton (Figure 1b).



**Figure 1.** (a) – *book*, *cage*, and *prism* conformations of the oxygen skeleton of (H<sub>2</sub>O)<sub>6</sub>; (b) – examples of orientational isomers in the *prism* conformation (H<sub>2</sub>O)<sub>6</sub>.

In this work, we study the effect of orientational isomerism of small neutral water clusters on their thermodynamic functions and concentration in the gas phase. All possible isomeric structures for (H<sub>2</sub>O)<sub>n</sub> clusters with n from 2 to 6 are considered. The thermodynamic parameters of clusters are determined directly by quantum chemical calculations.

The initial structures for the calculation are generated using the original program: first, from plane graphs with n vertices, those that can be transformed into a three-dimensional oxygen “skeleton” are selected, then for each oxygen “skeleton” all possible orientation isomers for which the Bernal–Fowler rules for water clusters are fulfilled are generated.

For each cluster structure under consideration, optimized geometry, vibrational frequencies and thermodynamic quantities (total energy  $E_{\text{tot}}$ , energy taking into account zero-point vibrations  $E_{\text{tot}} + \text{ZPE}$ , standard internal energy  $U_{298\text{ K}}^0$ , Gibbs energy  $G_{298\text{ K}}^0$  and enthalpy  $H_{298\text{ K}}^0$ ) are calculated using quantum chemical methods. The thermodynamic parameters of the reaction of the formation of a water cluster from individual molecules  $n\text{H}_2\text{O} \rightarrow (\text{H}_2\text{O})_n$ , as well as the equilibrium constant of this reaction and the concentration of clusters in the gas phase are calculated.

Additionally, the energy distribution of clusters and the dependence of the energy parameters of clusters on their geometry are studied.

When calculating the concentrations, all possible orientational isomers are taken into account, which makes it possible to obtain new results in comparison with the generally accepted approach, when the concentration is calculated only for a few of the most energetically favorable structures.

## References

- [1] Ignatov S. K., Sennikov P. G., Razuvaev A. G. et al. *J. Phys. Chem. A* **2004**, *108*, 3642–3649.
- [2] Jordan K. D., Sen K. *Chemical Modelling* **2017**, *13*, 105–131.
- [3] Vaida V. *J. Chem. Phys.* **2011**, *135*, 020901.
- [4] Anglada J. M., Hoffman G. J., Slipchenko L. V. et al. *J. Phys. Chem. A* **2013**, *117*, 10381–10396.

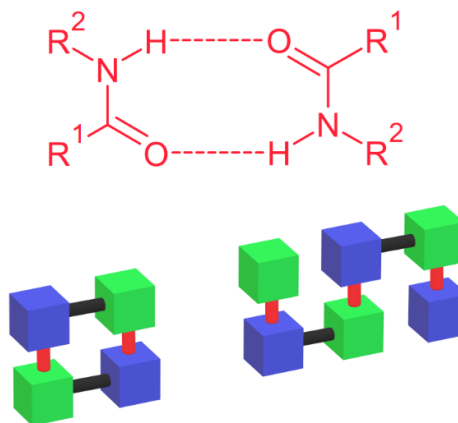
Acknowledgements. This work was supported by the Russian Foundation for Basic Research (projects No 20-03-00282 and No 18-43-520012).

AB INITIO INVESTIGATION OF THE FORMAMIDE HOMODIMERS ELECTRONIC STRUCTURE:  
FROM MULTIPLE HYDROGEN BONDS TO ADAPTIVE MATERIALS

*Shitov D.A.<sup>1</sup>, Tupikina E.Yu.<sup>1</sup>*

<sup>1</sup>Saint Petersburg State University, Saint Petersburg, Russia  
2<sup>nd</sup> year undergraduate student  
[shitovsky@gmail.com](mailto:shitovsky@gmail.com)

Polymeric materials with adaptive properties can be created, for example, by using hydrogen bonds for association between monomer building blocks. As we can see, spatial alternation of proton-donating NH<sub>2</sub> (D) and proton-accepting C=O (A) groups in the formamide molecule leads to the regioselective formation of an AD-DA homodimer by two hydrogen bonds N–H···O or an endless polymer chain (Figure 1).



**Figure 1.** Structural formula of formamide homodimers with various substituents R1, R2 (up) and two alternative types of self- association of the formamide-molecule (down), blue cube is D, green cube is A.

Thus, substituted homodimers of formamide can be considered as a part of monomeric block of supramolecular compound.

Such way of association has some sufficient advantages. On the one hand, by varying the set of substituents R<sup>1</sup> and R<sup>2</sup> (from H to EDG, EWG), we can vary the strength of hydrogen bonds in a wide range [1]. The chemical nature of these groups and their electronic structure, determines the strength and influence of individual hydrogen bonds on each other in the final non-covalent binding. It is important to note that hydrogen bonds in such homodimers affect each other, therefore the strength of a system of two hydrogen bonds is not equal to the algebraic sum of the strengths of each of the bonds taken separately [2]-[5]. On the other hand, hydrogen bonds, possessing the properties of reversibility and directionality, give the corresponding properties to the polymeric material, contributing to its adaptive nature.

This work is devoted to the *ab initio* quantum-mechanical calculations (MP2/aug-cc-pVDZ level of theory) of geometric parameters and electron density distribution of substituted formamide homodimers with R<sup>1</sup>, R<sup>2</sup> = H, EDG, EWG, sterically hindered substitute.

#### References

- [1] E. Yu. Tupikina, M. Sigalov, I. G. Shenderovich, V. V. Mulloyarova, G. S. Denisov, & P. M. Tolstoy. The Journal of Chemical Physics, 150(11), 114305, **2019**.
- [2] N. Kobko, L. Paraskevas, E. del Rio, & J. J. Dannenberg. Journal of the American Chemical Society, 123(18), 4348-4349, **2001**.
- [3] S. J. Grabowski, (Ed.). Dordrecht: Springer, **2006**.
- [4] P. Schuster, W. Mikenda, W. (Eds.). Springer Science & Business Media, **2012**.
- [5] G. Gilli, P. Gilli, P. Oxford University Press, **2009**.

*Shurygin A.V.*<sup>1</sup>, *Vovna V.I.*<sup>1</sup>, *Korochentsev V.V.*<sup>1</sup>, *Mirochnik A.G.*<sup>2</sup>

<sup>1</sup>Far Eastern Federal University, Vladivostok, Russia

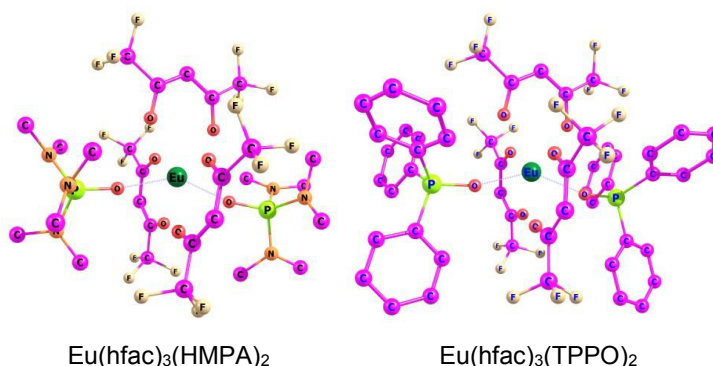
<sup>2</sup>Institute of Chemistry FEB RAS, Vladivostok, Russia

[shurygin.av@dvfu.ru](mailto:shurygin.av@dvfu.ru)

Lanthanide compounds are effective luminescent dopants for producing light-transforming materials, are used in manufacturing of emitters, are applied in detectors for detecting low water content in ethanol, in full-color tunable luminescent lyotropic liquid crystals. The main characteristic property of lanthanide adducts is luminescence – ligands, acting as antennas, absorb light energy, then, as a result of intramolecular transfer, pass it to the resonance levels of the lanthanide ion, causing luminescence [1].

In our work we present research results of the electronic structure of the ground and excited states of two adducts with the general formula  $\text{Eu}(\text{hfac})_3(\text{L})_2$ , formed by the trivalent complex  $\text{Eu}(\text{hfac})_3$  and two molecules  $\text{L} = \text{HMPA}$ ,  $\text{TPPO}$  (figure 1). Both compounds possess intense luminescence, the adduct  $\text{Eu}(\text{hfac})_3(\text{TPPO})_2$  demonstrates high light stability in polymer materials and provides intense triboluminescence [2].

Quantum chemical calculations were performed within DFT approximation using the FireFly 8.1. All calculations implied the B3LYP5. The Eu atom was described by a basis set augmented by an effective quasi-relativistic core potential (ecp52mwb). The other atoms were described by the 6-311G\*.



**Figure 1.** Calculated geometric structure of adducts in trans-isomer form.

The HOMO-LUMO energy gap under comparing different compounds is determined not only by the structure of the lower unoccupied molecular orbitals, but also by the higher occupied MOs. The weak absorbance of the groups  $\text{N}(\text{CH}_3)_2$  in a region of 220-350 nm of the adduct  $\text{Eu}(\text{hfac})_3(\text{HMPA})_2$  should lead to significant differences in the luminescence intensity relative to the adduct  $\text{Eu}(\text{hfac})_3(\text{TPPO})_2$ , but the experiment has shown that the intensity is weaker by only 5-10%. The disadvantages of the groups  $\text{N}(\text{CH}_3)_2$  are compensated for by the low energy gap value and lower density of excited states, that broadens the absorption region of the ligands hfac [3].

In the absorption spectrum of the adduct  $\text{Eu}(\text{hfac})_3(\text{TPPO})_2$  the band was found in a region of 240-290 nm caused by the vibrational structure of the phenyl groups, which corresponds to the transition  ${}^1\text{A}_{1g} \rightarrow {}^1\text{B}_{1u}$  of the benzene molecule. The obtained excitation spectra showed that for the adduct  $\text{Eu}(\text{hfac})_3(\text{TPPO})_2$  the corresponding excitation bands of phenyl groups are observed, from which the energy is transferred to the ligand (hfac) levels. The excitation spectra of the adduct  $\text{Eu}(\text{hfac})_3(\text{HMPA})_2$  contain the broadened, relative to the adduct  $\text{Eu}(\text{hfac})_3(\text{TPPO})_2$ , excitation band of the ligands hfac. The main band in the absorption spectra of two adducts with maxima at 301.4 nm and 304.8 nm is assigned to the transitions  $\pi_3\text{-}\pi_4^*$  of the ligands hfac, respectively.

### References

[1] Binnemans K. *Chem. Rev.* **2009**, *109*, 4283-4374

[2] Kalinovskaya I.V., Mirochnik A.G. *Russ. J. Phys. Chem. A.* **2014**, *88(3)*, 541-543

[3] Shurygin A.V., Vovna V.I., Korochentsev V.V., Mirochnik A.G., Kalinovskaya I.V., Sergienko V.I. *Spectrochim. Acta A Mol. Biomol. Spectrosc.* **2020**, *250*, 119397

Acknowledgements. This work was supported by the Russian Ministry of Science and Higher Education (the state task 0657-2020-0013).

# THE MESOIONIC PAIR CONCEPT

*Sizov G.N.<sup>1</sup>, Babaev E.V.<sup>1</sup>*

<sup>1</sup>Moscow State University, Moscow, Russia

Student

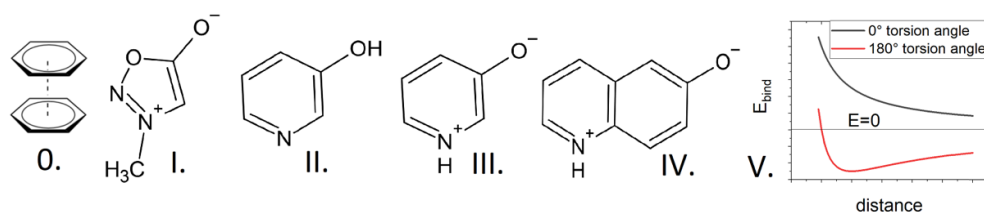
[george.n.sizov@gmail.com](mailto:george.n.sizov@gmail.com)

Mesoionic compounds are aromatic heterocycles with separated positive and negative charges. For these compounds, one formula cannot describe the electronic structure correctly. It is important to note that some compounds containing mesoionic rings are liquids. For example, 3-metylsydnone has a melting point about 36 °C, rather large dipole moment of 7.3 D, and a dielectric constant equal to 144 [1]. Such properties give a possibility of using some mesoionic compounds as super polar media similar to ionic liquids. However, mesoionic liquids (ML) do not contain free ions because they can be used in areas, where ions may be an extra constraint.

The understanding of chemical reaction mechanisms in ML requires the knowledge of intermolecular interaction, which takes place in their molecules. Computer simulations are crucial due to the limited experimental study of ML structures. In this paper, the special cases of intermolecular interaction were considered using the DFT calculation. The attention was focused on some structures with the sandwich geometry (Figure 1.0.). One of them is 3-metylsydnone (I on Figure 1), which has been investigated earlier in the paper [1]. In addition, the two hypothetical mesoionic structures (III and IV on Figure 1) and their pairs were investigated. They do not exist since the proton easily transfers from nitrogen to oxygen atom. However, they can be compared to identical covalent structure II.

The aim of this work is to implement the DFT calculations of mesoionic compounds geometry and analyze the surfaces of sandwich pair potential energy. The results presented in the framework of this study were performed using the GAMESS program [2]. The B3LYP and the long range-corrected B3LYP version named CAM-B3LYP [3] functionals were chosen. The 6-311++G\*\* basis set were used. All calculations were made for the gas phase. The optimized structures were tested with vibrational frequency analysis. The sandwich pair binding energy was defined as:  $E_{\text{bind}} = E(\text{pair}) - 2E(\text{one molecule})$

The obtained main features of sandwich pair potential energy surfaces are identical for all studied structures (Figure 1.V.). First, if the rotation angle in the pair is 0°, the binding energy is always positive at any distance between molecules. Second, if the distance between molecules is fixed, the minimal energy point is in rotation angle with the value of 180°. Third, there exists a distance, for which  $E_{\text{bind}}$  is negative. It is a local minimum point of potential energy surfaces. We propose to call this geometry a “mesoionic pair”.



**Figure 1.** 0: sandwich pair, I-IV: The structures under study, V: The main features of potential energy surfaces for the investigated systems.

The mesoionic pairs can be observed at a distance of 3.4 Å for the structure I, and 3.9 Å for structures III and IV using B3LYP functional. According to B3LYP calculations, the binding energies of mesoionic pairs are equal to -3.728, -1.578, -2.977 kcal/mol for the structures I, III, and IV, respectively, and we can conclude that the addition of another cycle to the system leads to the increase in binding energy. When using CAM-B3LYP instead of B3LYP, the binding energy of mesoionic pair decreases to -15.041 kcal/mol for structure III. The energy minimum in pair of covalent molecules II is -0.394 kcal/mol, and it is less than the binding energy of its mesoionic analogue III, for which  $E_{\text{bind}} = -1.578$  kcal/mol. Hence, the mesoionic structure is more likely to form the intermolecular pair than its covalent analogue.

## References

1. Stéphanie Cassel, Isabelle Rico-Lattes, Armand Lattes. *Science China Chemistry* **2010**, 53, 2063–2069.
2. Giuseppe M.J. Barca and co., *J. Chem. Phys.* **2020**, 152, 154102.
3. Takeshi Yanai, David P. Tew, Nicholas C. Handy, *Chemical Physics Letters*. **2004**, 393, 51–57.

# APPLICATION OF MM AND QM CALCULATIONS TO STUDY THE MOLECULAR AND CRYSTAL STRUCTURES OF BETULIN AND ITS SOLVATES

*Skakunova K.D.*<sup>1,2</sup>, *Rychkov D.A.*<sup>2</sup>

<sup>1</sup>Novosibirsk State University, Novosibirsk, Russia

<sup>2</sup>Institute of solid state chemistry and mechanochemistry of the siberian branch of the russian academy of sciences (ISSCM SB RAS), Novosibirsk, Russia

Student

[skakunova.kseniya@mail.ru](mailto:skakunova.kseniya@mail.ru)

Most of the known substances have low solubility and bioavailability. There are several ways to change the solubility, for example: changing the crystalline form or changing the molecule itself. A large number of natural compounds are capable of manifesting polymorphism and solvatomorphism. In solvatomorphism (pseudopolymorphism) the crystal structures of one substance differ, among other things, in their elemental composition due to the inclusion of solvent molecules. It is known that the difference in crystal structures can significantly affect the properties of a compound in the solid state (solubility rate, reactivity, stability, compressibility, etc.). Moreover, the presence of solvent molecules in solvatomorphs can significantly increase the toxicity of the drug. Thus, the creation of new drugs requires a comprehensive study of the crystalline forms of a substance, including polymorphic modifications, salts, cocrystals, hydrates and solvates [1]. That is why, understanding the form is important in the design of crystalline materials and using of computational methods for characterizing, quantifying and predicting various properties of solid active pharmaceutical ingredients continues to develop fast [2].

The object of study in this work is betulin (3 $\beta$ , 28-dihydroxy-20 (29) -lupene), a pentacyclic triterpene alcohol of the lupane type, obtained from birch bark. It has a pronounced biological activity as an anti-inflammatory, antitumor, antiviral agent, and therefore it has been widely studied recently. However, there is no information about its crystal structure and the structures of solvatomorphs are described mainly using crystallographic approach [3,4]. The physicochemical properties of betulin have been studied insufficiently. The aim of this work is to study the molecular and crystal structure of betulin and its solid forms using computational methods, systematize previously obtained data on solvatomorphs and interpret them in terms of interaction energies.

In this work, a comparative analysis of the known structures of betulin solvates is provided, the torsion angles of the molecule in solvate forms are analyzed. The calculation of the gas-phase molecular structure was carried out, the energy profiles were constructed. Based on the work carried out, nine possible conformers of the molecule were identified, of which two are realized in known structures according to the CSD search. Statistical analysis of possible interactions in new structures was performed using the method of constructing full interaction maps (FIM). The energies of bonds and crystal lattices of the known structures of betulin have been calculated. Crystal structure analysis was performed using energy characteristics. The data on the nature of the formation of existing forms are analyzed, classes of organic substances for obtaining new forms are proposed.

## References

- [1] Brittain HG. Polymorphism in Pharmaceutical Solids. vol 192. *Informa Healthcare USA, Inc.*; **2016**.
- [2] Bernstein J. *Cryst Growth Des.* **2011**;11(3):632-650
- [3] Drebuschak T.N., Mikhailovskaya A.V. et al. *J Struct Chem.* **2020**;61(8): 1260–1266
- [4] Yang D., Gong N. *J Pharm Sci.* **2016**;105(6):1867-1873

Acknowledgements. This work was supported by the Ministry of Higher Education and Science project FWUS-2021-005.



# QUANTUM ELECTRONIC PRESSURE AS THE INDICATOR OF HALOGEN AND Pnictogen BONDS IN MOLECULAR CRYSTALS

*Sobalev S.A.,<sup>1</sup> Matveychuk Y.V.<sup>1</sup>, Bartashevich E.V.<sup>1</sup>*

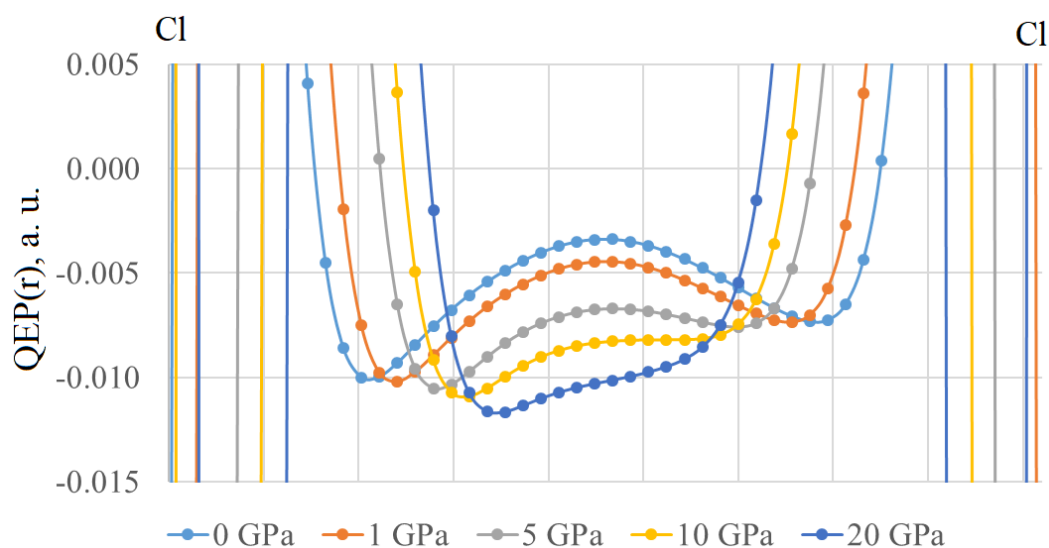
<sup>1</sup>South Ural State University (National Research University), Chelyabinsk, Russia

PhD student

[sobalevsa@susu.ru](mailto:sobalevsa@susu.ru)

A number of physicochemical properties of molecular crystals are directly determined by the features of noncovalent bonds such as the halogen [1], chalcogen [2], pnictogen bonds. The mechanical properties of crystals such as the ductility, softness, brittleness or elasticity are no exception [3, 4]. Understanding the nature of electrostatically driven noncovalent bonds is directly related with an idea of anisotropy of electronic features of the outer atomic shells.

The quantum electron pressure function QEP(r) [5] was used as a characteristic of electron density in real space of crystals under pressure. Physically QEP(r) characterizes the variation of the internal energy under a local deformation that changes the volume of a small element of the electron continuum without changing its shape.



**Figure 1.** The change of Quantum Electronic Pressure along the Cl...Cl halogen bond under the hydrostatic compression of Cl<sub>2</sub> crystal ( $\sigma$ -hole on the left).

A comparison of the behavior of the quantum electron pressure function for noncovalent bonds in the series of Hal<sub>2</sub> and HalC(NO<sub>2</sub>)<sub>3</sub> crystals, where Hal = Cl, Br, I, modeling under the external hydrostatic pressure were carried out. It was found that QEP(r) allows the identification of both electrophilic and nucleophilic regions (Figure 1), as well as the relationship between the behavior of the function for non-covalent bonds of the crystal and the crystal mechanical properties [6]. In addition, the function IQPF(r) [5] was considered, which makes it possible quantitative comparison of characteristics of the noncovalent bonds under the pressure.

## References

- [1] Desiraju G.R., Ho P.S., Kloo L. Legon A.C., Marquardt R., Metrangolo P., Politzer P.A., Resnati G., Rissanen K. *Pure Appl. Chem.* **2013**, *85*, 1711–1713.
- [2] Aakeroy C.B., Bryce D. L., Desiraju G. R., Frontera A., Legon A. C., Nicotra F., Rissanen K., Scheiner S., Terraneo G., Metrangolo P. & Resnati G. *Pure Appl. Chem.* **2019**, *91*, 1889-1892.
- [3] Coudert F.-X., Fuchs A. H. *Coord. Chem. Rev.* **2016**, *307*, 211–236.
- [4] Mishra A. K., Murli C., Pandey K. K., Sakuntala T., Poswal H. K., Verma A. K. *J. Phys. Chem. B* **2020**, *124*, 373–379.
- [5] Tsirelson V. G., Stash, A. I., Tokatly, V. *Acta Cryst. B* **2019**, *75*, 201–209.
- [6] Bartashevich E. V., Sobalev S. A., Matveychuk Y. V., Tsirelson V. G. *Acta Cryst. B* **2020**, *76*, 514–523.

Acknowledgements. This work was supported by the Russian Foundation for Basic Research (project No 20-03-00240).

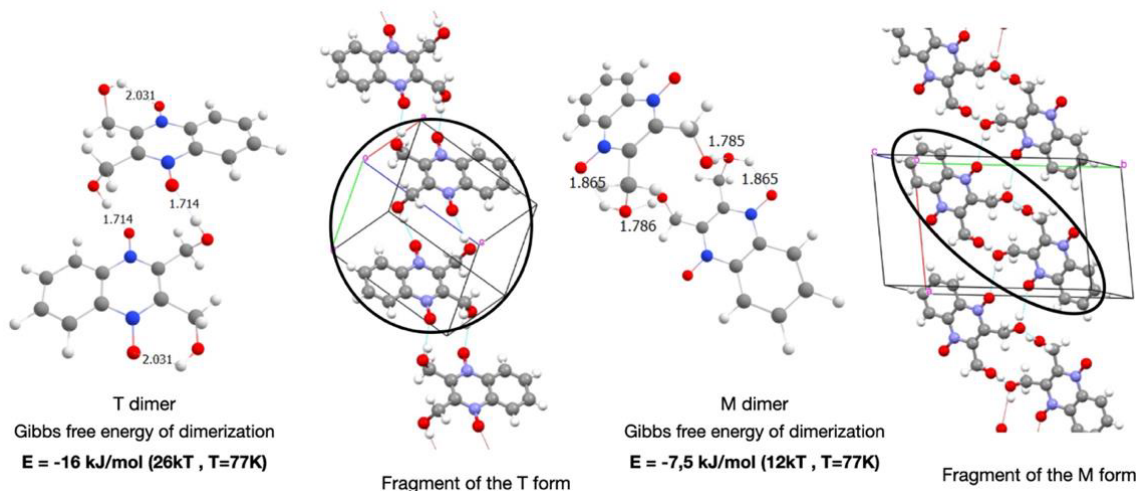
A prospective approach to enhance an effectiveness of drugs is particles size reduction down to nanoscale [1]. A common phenomenon in the production of drug nanoparticles is the appearance of new polymorphic modifications with different biomedical properties [2].

A new method for obtaining nanoparticles has been developed [3]. The method consists of sublimation of initial drug powder, transfer of drug molecules by carrier gas flow and condensation of gas mixture on the surface, cooled with liquid nitrogen. Series of experiments on obtaining of antibacterial drug dioxidine nanoparticles was carried out [4] (Table 1). According to the X-ray powder diffraction data, the phase composition of the obtained nanoparticles depends on the flow of the carrier gas.

**Table 1.** Phase composition of dioxidine nanoparticles depending on the CO<sub>2</sub> flow

Flow of CO <sub>2</sub> , mole/hour	The ratio of condensation rates CO <sub>2</sub> /dioxidine	Phase composition	Particle size, nm
0	0	T:H = 7 : 1	414±80
0,2	1,85	T:M = 2 : 1	120±24
0,45	4,16	T:M = 1 : 1	118±23
1,00	9,24	T:M = 2 : 3	108±22
4,5	41,63	T:N = 3 : 2	56±11
10,0	92,50	T:N = 3 : 2	51±10

The purpose of this work is to explain the observed dependence of the triclinic (T) and monoclinic (M) crystal phase dioxidine ratio on the carrier gas CO<sub>2</sub> flow. DFT B3LYP/(aug)-cc-pVDZ calculations using program ORCA were made for formation of dioxidine dimers in absence and in presence of various amounts of CO<sub>2</sub> molecules. Structure of T dimer corresponds to molecular packing in the triclinic crystalline form, structure of M dimer corresponds to monoclinic crystal form. Thus, formation of the most thermodynamically stable dimer leads to consequent nuclei formation and thereby, consequent nanocrystallites formation. T dimer was established to be more stable than M dimer in absence of CO<sub>2</sub>. In presence of CO<sub>2</sub> more stable conformations of M dimer exist, which leads to formation of monoclinic phase.



**Figure 1.** Fragments of the triclinic and monoclinic crystalline forms (on the right) and calculated geometries of consequent dimers and its dimerization energies (on the left).

#### References

- [1] Higashi K., Ueda K., Morible K. *Adv. Drug Del. Rev.* **2017**, 117, 71.  
 [2] Lee E.H. *Asian J. Pharm. Sci.* **2014**, 9, 163-175.  
 [3] Комаров В.С., Михалев С. П., Морозов Ю. Н., Сергеев Г.Б. Патент РФ № 2295511.  
 [4] Shabatina T.I., Morozov Y.N., Soloviev A.V., Shabatin A.V., Vernaya O.I., Chernyshev V.V., Melnikov M.Y., *Nanomaterials*, **2021**, 9 [In press].

# USING SUPERVISED MACHINE LEARNING TO PREDICT THE STRUCTURE AND ENERGIES OF MAGNESIUM NANOCCLUSERS

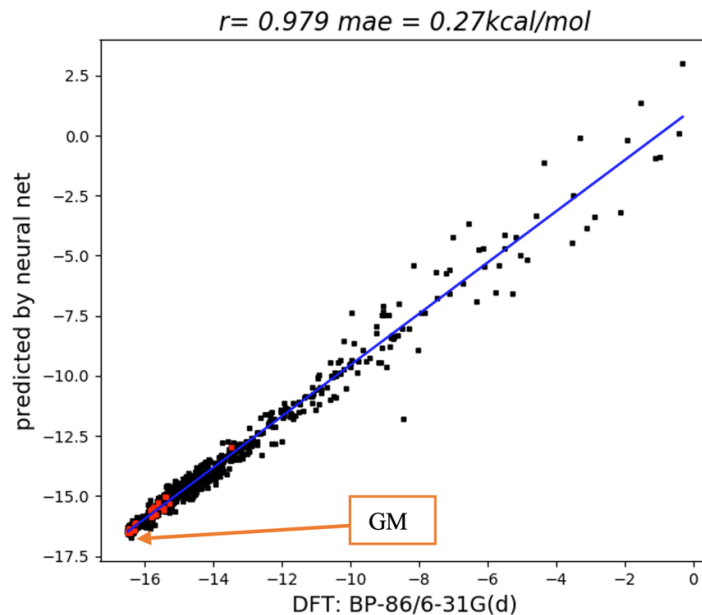
*Steshin I.S.,<sup>1</sup> Avdoshin A.A.,<sup>1</sup> Ignatov S.K.<sup>1</sup>*

<sup>1</sup>Nizhny Novgorod State University N.I. Lobachevsky, Nizhny Novgorod, Russia

Student

[ilya.steshin@icloud.com](mailto:ilya.steshin@icloud.com)

Nanoparticles (NPs) and subnanosized clusters of metals are catalysts for many important chemical processes, including highly selective organic synthesis, utilization of exhaust gases, and production of renewable fuels. At low nuclearity ( $n < 150$ ), the properties of NPs are extremely dependent on their structure and shape. This is a serious problem for the theoretical prediction of the structure, physicochemical properties, and reactivity of NPs. Modern methods of quantum chemistry in this range of nuclearities are characterized by high computational costs, and the existing classical empirical pair and metallic potentials (Lennard-Jones, Gupta, Sutton-Chen, EAM, etc.) are not able to accurately reproduce the structure of the global minima of NPs and the energy distribution of their local minimums. The more flexible and comprehensive potentials can be elaborated using the modern neural network (NN) algorithms. In the current work, we propose a new approach to presenting data for constructing the NN potential (NNP) for predicting the energies of  $Mg_n$  clusters ( $n = 20-25$ ). Depending on the cluster nuclearity, NNPs have to describe different atomic environments. In this work, methods of finding of the signatures of atomic environment for varying cluster nuclearities are of special interest and their use for predicting the energies of structures of large nuclear values are considered. The input data for the neural network are the symmetry functions proposed earlier [1], which allow describing the position of each atom by functions independent of the coordinate system. In distinction from the above NN, our NN implementation uses so called "phantom atoms" (PA) i.e. matrices with zero values of symmetry functions describing the absent atoms during training the NN on smaller nuclearities. PA do not affect the predicted structures, but allow one to train NN for several different nuclearities at once. The NNP was trained on the limited set of DFT optimized structures and energies available for  $n=18-20$  and was applied for prediction of the cluster structures in the range of  $n=21-25$ . The obtained results were compared with the test set of the DFT optimized structures of the same nuclearity. Figure 1 demonstrates comparison between the predictions of NP and the DFT results for the cluster  $Mg_{25}$ .



**Figure 1.** Comparison between the per atom binding energies of  $Mg_{25}$  predicted by neural network and the DFT (BP86/6-31G(d)) results. Black points – randomly generated structures. Red points – optimized local minima and global minima (GM).

## References

[1] Behler J. *J. Chem. Phys.* 2011, 134, 074106.

Acknowledgements. This work was supported by the Russian Foundation for Basic Research (projects No. 20-03-00282 and 18-43-520012).

# ANTIMICROBIAL ACTIVITY OF DIHYDROQUERCETIN AGAINST *E. COLI*

*Taldaev A.Kh.*<sup>1,2</sup>, *Terekhov R.P.*<sup>1</sup>, *Selivanova I.A.*<sup>1</sup>

<sup>1</sup>Sechenov First Moscow State Medical University (Sechenov University), Moscow, Russia

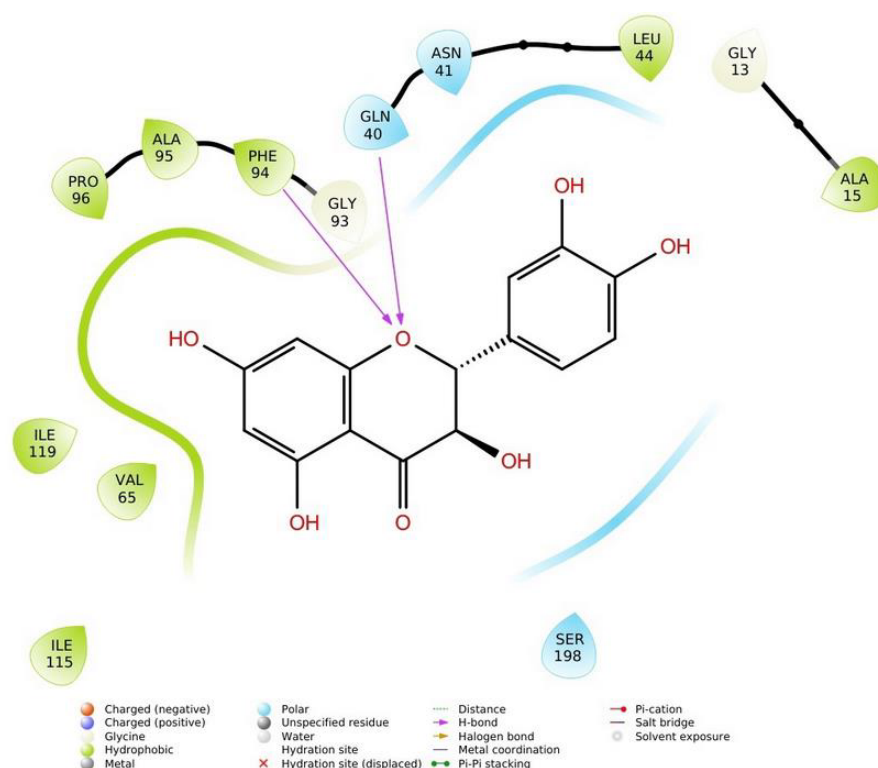
<sup>2</sup>V.N. Orekhovich Institute of Biomedical Chemistry, Moscow, Russia

Undergraduate student

[t-amir@bk.ru](mailto:t-amir@bk.ru)

Dihydroquercetin (DHQ) is a flavonoid compound and industrially produced as an active pharmaceutical ingredient. It has a wide spectrum of pharmaceutical activity including anti-oxidant [1] and anti-inflammatory [2]. Quercetin is very similar to DHQ structure and was tested *in vitro* on *E. Coli* Enoyl-acyl carrier protein reductase (ENR). It showed the inhibition capacity of this protein [3]. Investigation of the possibility of DHQ to suppress *E. Coli* growth *in vivo* and prediction of the action mechanism by *in silico* methods were aims of our study.

The moderate activity of DHQ against *E. Coli* was found in the agar diffusion test. The growth inhibition zone of DHQ was 14±0.8 mm. The crystalline structure of ENR was obtained from RCSB Protein Data Bank (PDB ID: 1C14) [4]. We performed re-docking of triclosan and docking of DHQ into one site of ENR in SwissDock.  $\Delta G$  values were -7.5 kcal/mol for triclosan and DHQ. Molecular dynamics (MD) simulation was done of the docked protein-DHQ complex with a length of 100 ns in NPT ensemble. The complex is stable during MD simulation, the minimum distance between ENR and DHQ did not fluctuate significantly. The interaction map between DHQ and ENR amino acid residues is presented in Figure 1.



**Figure 1.** Interactions between DHQ and ENR in the major conformation of the complex from MD simulation.

Thus, the moderate antibacterial of DHQ was found *in vivo* and the potential mechanism of inhibition was investigated by *in silico* methods. This mechanism could be similar to well-known agent triclosan but DHQ has a better safety profile [5]. Additionally, screening via cheminformatics methods of other bacterial targets is interesting.

## References

- [1] Ilyasov I.R., Beloborodov V.L., *Chem. Papers* **2018**, 72, 1917–1925.
- [2] Terekhov R.P., Selivanova I.A. *Bull. Sib. Med.* **2019**, 18, 101-106.
- [2] Sharma S.K., Parasuraman P. *J. Med. Chem.* **2007**, 50, 765–775.
- [4] Qui X., Abdel-Meguid, S.S. *Protein Science* **1999**, 8, 2529–2532.
- [5] Terekhov R.P., Selivanova I.A. *Bull. Exp. Biol. Med.* **2021**, 170, 444–447.

Terashkevich V.A.<sup>1</sup>

<sup>1</sup>Lomonosov Moscow State University, Moscow, Russia  
[terversik@yandex.ru](mailto:terversik@yandex.ru)

Red ( $A^2\Pi - X^2\Sigma^+$ ) and violet ( $X^2\Sigma^+ - B^2\Sigma^+$ ) bands of CN radical have been studied extensively both experimental and theoretical methods since the registration of the emission spectrum of a radical in the interstellar medium [1]. The overwhelming majority of works are devoted to the identification and interpretation of vibrational-rotational frequencies, the creation of an exhaustive database containing very highly excited transitions with large values of the quantum numbers  $\nu$  and  $J$ . The presence of  $\Lambda$  - doubling was experimentally recorded for the first excited  $A^2\Pi$  state, and the parameters of doubling ( $p$ ,  $q$ ) were determined in work [2]. These parameters are given for the values of the quantum vibrational number  $\nu$ , which takes values from 0 to 22. However, at the moment there are no works aimed at identifying the nature of doubling (the  $^2\Sigma^+$  state, which has the greatest interaction with the  $A^2\Pi$  state, has not been identified). This question can be answered by obtaining non-adiabatic matrix elements of spin-orbit,  $\xi_{ij}$ , and electron-rotational ( $L_{\pm}$  - uncoupling) interactions. By transforming the functions of intramolecular interaction using the Van Vleck contact transformations, it becomes possible to estimate the contribution from each pair of interacting states  $A^2\Pi - (1-5)^2\Sigma^+$  to the parameters  $p$  and  $q$  and, thereby, to establish the dominant interaction responsible for the origin of doubling. Thus, the aim of this work was to obtain potential curves of electronic states  $A^2\Pi$ ,  $(1-5)^2\Sigma^+$ , as well as non-adiabatic matrix elements of intramolecular interaction using nonempirical calculations.

*Ab initio* calculation of the electron energy was carried out by the method of the SA-CASSCF method in the active space of 10 orbitals. Further consideration of dynamic correlation was carried out using the method of configuration interaction (MR-CISD). The description of both atoms of the CN radical was carried out using aug-cc-pwCVQZ – DK full electronic basis set. All electronic structure calculation were done used MOLPRO software package

Analysis of the obtained matrix elements of the spin-orbit and electron-rotational interactions for pairs of interacting states  $A^2\Pi - (1-5)^2\Sigma^+$  showed that the strongest is the interaction of the  $A^2\Pi$  state with the  $B^2\Sigma^+$  state in the range of internuclear distances in region  $R \in 0.8$  to  $1.3 \text{ \AA}$ . With an increase in the internuclear distance, a decrease in the contribution from this interaction and an increase in the influence of  $(3-5)^2\Sigma^+$  electronic states are observed. The calculation of the  $\Lambda$  - doubling parameters and comparison with the known experimental values (in the region of  $\nu = 0 - 6$ ) demonstrated good agreement between the two data sets.

#### References:

- [1] McKellar A. *The Astronomical Society of the Pacific*. **1940**. 52. 187.  
 [2] Ram R., Bernath P. *The Astrophys. J. Suppl. Series*. **2011**. 194. 34.

Acknowledgements. This work was supported by the Russian Science Foundation (project No 18-13-00269)

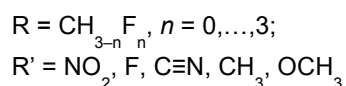
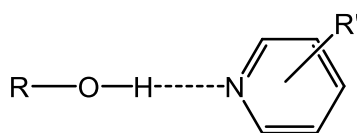
APPLICABILITY OF IR SPECTRAL PARAMETERS  
FOR ESTIMATION OF THE STRENGTH OH...N HYDROGEN BONDS

*Titova A.A.<sup>1</sup>, Tupikina E.Yu.<sup>1</sup>*

<sup>1</sup>Saint Petersburg State University, Saint Petersburg, Russia  
2<sup>nd</sup> year undergraduate student  
[aatitova1210@gmail.com](mailto:aatitova1210@gmail.com)

Non-covalent adaptive modern materials are often built from monomers, associated with hydrogen bonds. The properties of such materials are largely defined by the strength of these interactions. However, the evaluation of a single hydrogen bond strength is often a quite complicated task, especially for complexes with multiple hydrogen bonds. Thus it is necessary to use indirect methods – estimations of energies based on values of measurable spectral parameters (IR and NMR) [1,2].

In this work we investigated complexes ROH...NC<sub>5</sub>H<sub>4</sub>R' (where R = CH<sub>3-n</sub>F<sub>n</sub>, n = 0,...,3, R' = NO<sub>2</sub>, F, C≡N, CH<sub>3</sub>, OCH<sub>3</sub>, see Figure 1) by means of quantum chemistry. We calculated equilibrium geometries of the model complexes, energy of complexation and spectral IR parameters at B3LYP/6-311++g(d,p) level.



**Figure 1.** Scheme of the studied complexes.

The sensitivity of IR parameters (stretching vibration frequencies and intensities) to the strength and geometry of hydrogen bonds were investigated. It was shown that the change of proton-donating group vibrational frequency is suitable for qualitative estimations of hydrogen bond properties.

#### References

- [1] Tupikina, E. Y. et al. Correlations of NHN hydrogen bond energy with geometry and 1 H NMR chemical shift difference of NH protons for aniline complexes. *J. Chem. Phys.* **2019**, *150*, 114305.  
[2] Badger, R. M. & Bauer, S. H. Spectroscopic studies of the hydrogen bond. II. The shift of the O-H vibrational frequency in the formation of the hydrogen bond. *J. Chem. Phys.* **1937**, *5*, 839–851.

Acknowledgements. This work was supported by grant of the President of the Russian Federation number MK-946.2020.3. Computational resources were provided by Computer Center of Saint-Petersburg University Research Park (<http://www.cc.spbu.ru/>).

# MODELING THE EFFECT OF ORDER AND DISORDER IN METAL ALLOYS ON THE RATE OF HETEROGENEOUS ELECTRON TRANSFER

Tuzov D.A.,<sup>1</sup> Nazmutdinov R.R.<sup>1</sup>

<sup>1</sup>Kazan National Research Technological University, Kazan, Russia

Student

[mr.hulkbuster@gmail.com](mailto:mr.hulkbuster@gmail.com)

The electronic structure of disordered systems attracts attention for a long time [1]. Recently the electrochemical behaviour of ordered and disordered PtCo alloys at the oxygen reduction was addressed both experimentally and theoretically [2]; the ordered electrode surface was found to be catalytically more active. However, some general aspects of redox activity of ordered (disordered) electrodes are still poorly understood so far. In this work we present a simple and robust model which is aimed at predicting qualitatively interesting trends in the kinetics of outersphere electron transfer across ordered and disordered bimetallic alloys with different composition. We consider a monoatomic wire consisting of  $N$  atoms of two different type ( $N$  amounts to several hundreds) with free boundary conditions, as well as with ring closure. The electronic structure of such a system is treated in the framework of Hückel method. The atom ionization energy ( $\alpha$ ) and coupling constant ( $\beta$ ) are used as input parameters. An original code has been written for matrix diagonalization with the help of *Matlab* program package. Disordered configurations were generated randomly with subsequent averaging of calculated characteristics. The primary attention is paid on the density of electronic states (DOS), as this quantity (especially in the vicinity of the Fermi level) is an important contribution to the rate constant of heterogeneous electron transfer (ET) in the non-adiabatic (weak coupling) regime [3]. Another key quantity in the ET kinetics is the effective resonance integral ( $V_{if}$ ) which originates from the electrode – reactant orbital overlap [3]. The  $V_{if}$  values were estimated on the basis of perturbation theory [4]. In our approach the electrode wave function near the Fermi level is treated in terms of free electrons restricted by a one-dimensional potential and depends on the HOMO energy of the electrode which plays the role of work function. A reactant is modeled as a hydrogen-like ion for simplicity. The preliminary results point to a higher redox activity of ordered electrodes as compared with disordered ones.

## References

- [1] Ziman J.M. *Models of disorder*. Cambridge University Press, Cambridge, 1979.
- [2] [Lebedeva M.V.](#), [Pierron-Bohnes V.](#), [Goyhenex C.](#) et al. *Electrochimica Acta*. **2013**, *108*, 605-616.
- [3] Kuznetsov A.M. *Charge Transfer in Physics, Chemistry and Biology. Mechanisms of Elementary Processes and Introduction to the Theory*. Gordon and Breach Science Publishers, Berkshire, **1995**.
- [4] Nazmutdinov R.R., Bronshtein M.D., Zinkicheva T.T., Glukhov D.V. *Int. J. Quantum Chem.* **2016**, *116*, 189-201.

Acknowledgements. This work was supported by the Russian Foundation for Basic Research (project No 20-03-00772).

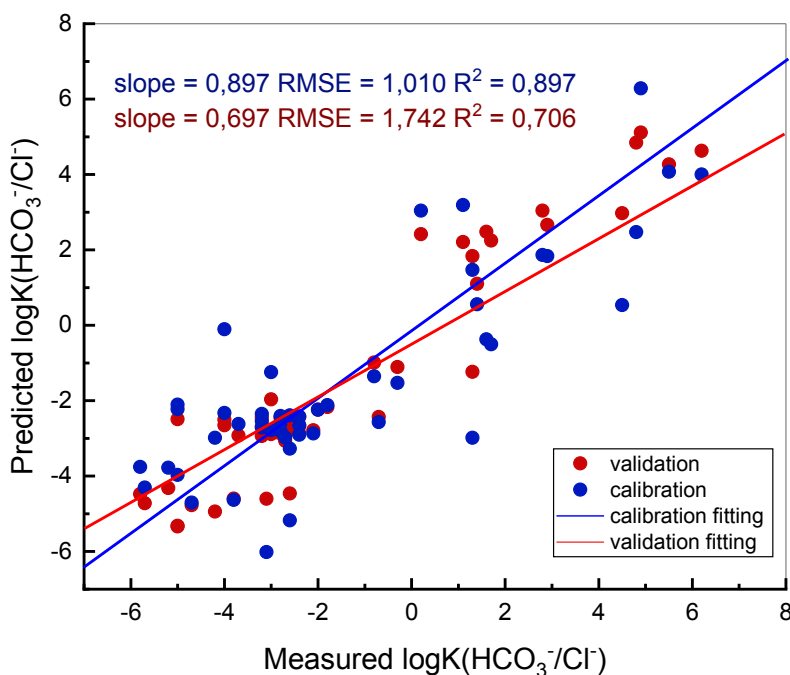
# FEASIBILITY STUDY OF QSPR AS A TOOL FOR $\text{HCO}_3^-/\text{Cl}^-$ POTENTIOMETRIC SELECTIVITY PREDICTION

*Vladimirova N.*,<sup>1</sup> *Kirsanov D.O.*<sup>1</sup>

<sup>1</sup>Saint Petersburg State University, Saint Petersburg, Russia  
PhD Student  
[st040543@student.spbu.ru](mailto:st040543@student.spbu.ru)

QSPR (Quantitative Structure-Property Relationship) is a modern research tool [1], where the chemical structure of organic compound is characterized with formal descriptors and regression model is built to relate the structure with properties of the compound. It has a number of applications in pharmaceutical industry, development of novel materials, etc. Amongst these materials are ionophores for potentiometric sensors. The mathematical prediction of ionophores' properties is very perspective due to long and laborious procedure of experimental procedures, such as synthesis and characterization of each new membrane active compound. The number of proposed anion-selective ligands for membrane ion sensor is much smaller than that for cations because of the following reasons: inorganic anions have widely different shapes (unlike spherical cations), denser solvate shells of anions, some forms exist only in narrow pH range. The development of the sensors with selectivity towards hydrophilic anions, like, e.g. carbonate has specific problems. Since ion sensors with PVC-plasticized membranes are widely employed in routine analytical procedures as a convenient and inexpensive tool for activity assessment, an attractive opportunity would be to create a model that could predict the selectivity of ligand towards carbonate without real synthesis and characterization of the corresponding sensors.

In this work, based on 48 ligand structures suggested in literature for carbonate sensing we have developed a model for prediction of  $\log K(\text{HCO}_3^-/\text{Cl}^-)$ . Substructural Molecular Fragments (SMF) were used to describe the structure of compounds, where fragments were considered as sequences of bonds and atoms. The Projection on Latent Structures (PLS) method was used to calculate the regression model. The obtained model was tested in prediction of selectivity of several newly synthesized ligands. The details on the results will be provided in the presentation.



**Figure 1.** The QSPR modeling of the selectivity of potentiometric sensors towards  $\text{HCO}_3^-$  in the presence of  $\text{Cl}^-$ .

## References

[1] Katritzky A.R., Lobanov V.S. and Karelson M. *Chem. Soc. Rev.*, **1995**, 24, 279-287.

Acknowledgements. This work was supported by RFBR project #20-33-70272.



STRUCTURE DETERMINATION AND ATOMIC PROPERTIES OF METAL CLUSTERS IN ESI-MS SPECTRA OF PRECATALYST SOLUTIONS WITH BOMD, DFT, AND QTAIM

*Vlasova Y.S.*<sup>1</sup>, *Bondarenko A.A.*<sup>2</sup>, *Polynski M.V.*<sup>2,3</sup>, *Ananikov V.P.*<sup>2,3</sup>

<sup>1</sup>Moscow State University, Moscow, Russia

<sup>2</sup>Saint Petersburg State University, Saint Petersburg, Russia

<sup>3</sup>Zelinsky Institute of Organic Chemistry, Moscow, Russia

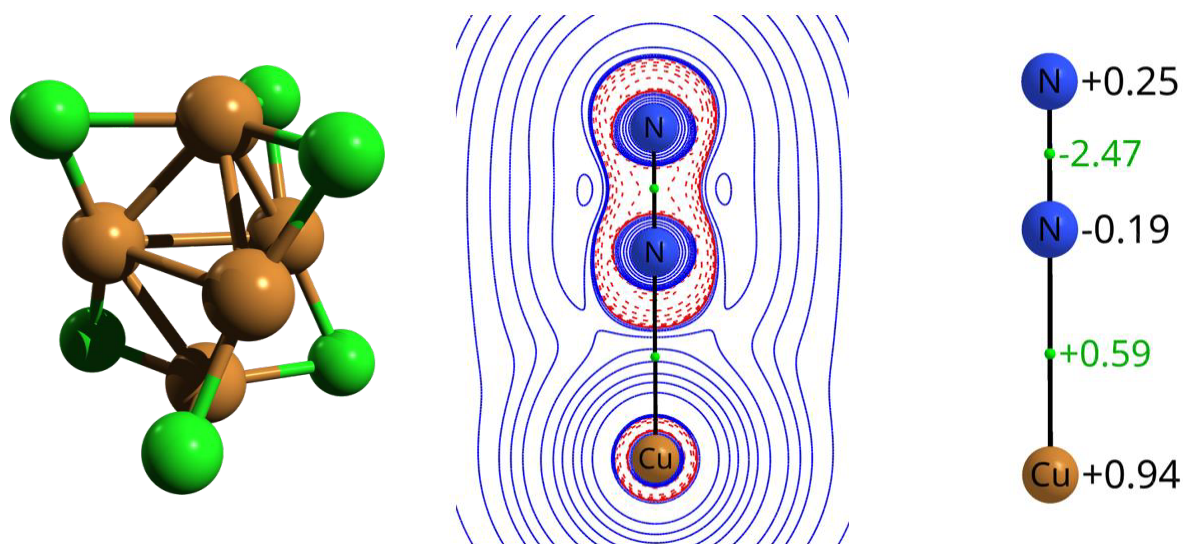
Student

[iuliia.vlasova@chemistry.msu.ru](mailto:iuliia.vlasova@chemistry.msu.ru)

Copper and palladium compounds have proven to be highly efficient catalysts for cross-coupling in organic chemistry. As one of the leading examples, Sonogashira reaction was studied to understand the reaction mechanism in further details and to find approaches for the rational catalyst design. Electrospray ionization mass spectrometry (ESI-MS) is an extremely accurate and express method, however, challenging data analysis is a limiting factor. Indeed, data-rich spectra are hard to analyze without automation. The main problem is that chemical structure is not determined in routine ESI-MS. As the determination of mechanisms of catalytic reactions is generally impossible without structural information, we aimed to boost ESI-MS with quantum chemical methods that allow nowadays *de novo* structure determination.

Identification of copper (I) chloride, palladium (II) chloride, and the mixture of palladium and copper chlorides in acetonitrile spectra was carried out manually and by a newly script designed to reproduce the results of manual heuristic peak identification. Spectra in both positive and negative modes were analyzed. Pronounced clustering of Cu and Pd chlorides in the spectra was observed, as well as binding of impurities (ligands: O<sub>2</sub>, N<sub>2</sub>, etc.) and redox processes (Cu(II) and Pd(I) formation).

Born-Oppenheimer MD (BOMD) revealed conformational mobility of [Cu<sub>n</sub>Cl<sub>m</sub>L<sub>z</sub>]<sup>+/-</sup> and [Pd<sub>n</sub>Cl<sub>m</sub>L<sub>z</sub>]<sup>+/-</sup> under the conditions of the mass analyzer chamber at the temperature of the nebulizer gas (200 °C). Low-energy conformers of particular ions were found, the nature of chemical bonds in these conformers was determined with Bader's topological analysis of the electronic density. Binding modes with impurity ligands were determined with BOMD and the structures were refined by DFT modeling.



**Figure 1.** *Left:* optimized structure of [Cu<sub>5</sub>Cl<sub>6</sub>]<sup>-</sup>; *middle:* Laplacian contour map and (*right*) charges and Laplacian in bond critical points in [Cu-N≡N]<sup>+</sup>.

Calculations of low-energy conformers were carried out by meta-dynamics and molecular dynamics with GFN2-xTB Hamiltonian, geometry optimizations were performed at the OLYP-D3(BJ)/ma-def2-SVP level. The ZORA method was used to obtain electronic density distribution for the analysis within the QTAIM in AIMALL program. All DFT calculations were performed in ORCA 4.1.2.

Acknowledgments. Authors are grateful to Daniil Boiko and Dmitry Eremin for helpful discussions, especially those on the binding of impurity ligands to ions in ESI-MS spectra.

# INTERACTION OF NEW ANTITUMOR DRUG DIOXADET WITH LIPID DOUBLE LAYER AS MODEL CELL MEMBRANE

*Yakush E.*<sup>1,2</sup>, *Kim A.*<sup>1,2</sup>

1.

<sup>1</sup>Voevodsky Institute of Chemical Kinetics and Combustion SB RAS, Novosibirsk, Russia

<sup>2</sup>Novosibirsk State University, Novosibirsk, Russia

Student

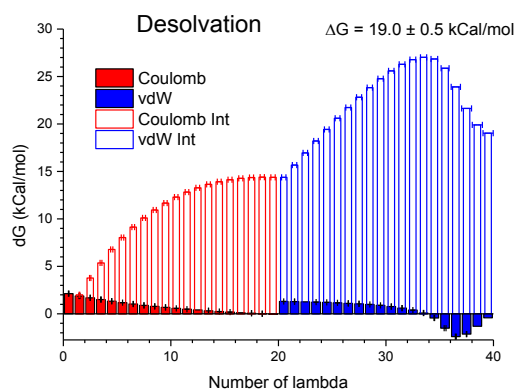
[elenayakush43@gmail.com](mailto:elenayakush43@gmail.com)

Dioxadet is a small molecule from the class of alkylating ethylenimines which was developed and is being actively studied at the NMRC of Oncology, St. Petersburg. It has been experimentally proven that dioxadet is an effective antitumor agent. The drug has passed the second phase of clinical testing, is approved for production and use in clinical practice. Compared to other compounds of its class, dioxadet is less toxic and has fewer side effects [1].

The improvement of the drug is hindered by the almost complete lack of accurate information about the mechanism of its action. Therefore, this study is devoted to the physicochemical interaction of dioxadet with the phospholipid bilayer as a model of the cell membrane, namely, the answer to the question of how the drug penetrates a biological cell through its membrane at the very first stage of the drug's action.

All simulations were performed using the GROMACS 2018 package. The dioxadet molecule is parameterized in ATB Builder. For comparison with the experimental results, a lipid bilayer consisting of distearylphosphatidylcholine (128 DSPC) molecules with 1 dioxadet molecule in water (SPC) was modeled at a temperature of 300 K and a constant pressure of 1 bar. During the first 5 ns, the dioxadet molecule settled on the membrane from the water and practically did not move during the entire simulation time of 600 ns. To obtain more theoretical information about the behavior of dioxadet under conditions close to the human body, simulations were performed with membranes composed of DOPC and DSPC lipids at a temperature of 310K. The DSPC membrane in contrast to DOPC membrane has an ordered structure at chosen temperature. Because of this difference different results were obtained: dioxadet penetrates under the surface of the DOPC membrane.

The free energy of solvation of dioxadet in water was calculated by the Bennett acceptance ratio method and amounted to  $-19 \pm 0.5$  kcal/mol. 20 intermediate states were used for each of Coulomb and van der Waals interaction decoupling (100 ns to each simulation). Also, the free energy profile of dioxadet's penetration through the membranes by the umbrella sampling method (60 windows of 100 ns each) was calculated. A potential barrier was found in the middle of each studied membrane. The profile of diffusion coefficient and permeability were estimated for both DSPC and DOPC membranes. In general, it is shown that the membrane is permeable to dioxadet molecules.



**Figure 1.** Free energy of desolvation of the dioxadet molecule in water.

## References

[1] *J. of Chemotherapy* **2016**, 28.3, 203-209.

SUBLIMATION ENTHALPY PREDICTION AND THEORETICAL THERMODYNAMIC STUDY  
OF SOME MESOIONIC TETRAZOLIUM 5-AMINIDES

*Yurkshtovich Y.N.<sup>1</sup>, Blokhin A.V.<sup>1</sup>*

<sup>1</sup>Belarusian State University, Minsk, Belarus  
Student  
[yanayurksht@gmail.com](mailto:yanayurksht@gmail.com)

Mesoionic derivatives of tetrazoles represent an interesting for thermodynamic study class of organic substances, since they can be used as components of highly efficient fuels and thermally destructible systems, due to high positive values of heats of formation, thermal stability and high nitrogen content. Moreover, these substances are widely used in organic synthesis in cycloaddition reactions [1]. Also, the relevance of the development of theoretical methods for calculating the thermodynamic parameters of tetrazole derivatives is explained by the complexity of the experiment due to their explosiveness. In this work we present the results of theoretical thermodynamic study of 1,3-di-*tert*-butyltetrazolium-5-aminide (TBU) and 1-methyl-3-*tert*-butyltetrazolium-5-aminide (ME).

The standard thermodynamic functions (entropy, heat capacity, reduced enthalpy and reduced Gibbs energy) of TBU and ME in the ideal gas state were calculated using the statistical thermodynamics approach in temperature range (0 – 1000) K. Geometry optimization and calculation of normal vibrational frequencies were done using the DFT/B3LYP/6-311G+(3df,p) level of theory. Standard enthalpies of formation of TBU and ME in the ideal gas state at  $T = 298.15$  K were calculated using the isodesmic reactions approach in the framework of composite quantum chemistry method G4 [2]. Standard thermodynamic properties of the substances in the ideal gas state at  $T = 298.15$  K are represented in Table 1.

**Table 1.** Standard thermodynamic properties of the substances in the ideal gas state at  $T = 298.15$  K

	$C_{p,m}^0$	$\Delta_0^{298} S_m^o$	$\Delta_0^{298} H_m^o / T$	$-\Delta_0^{298} G_m^o / T$	$\Delta_f H_{298}^o, \text{ kcal} \cdot \text{mol}^{-1}$
	$\text{cal} \cdot \text{mol}^{-1} \cdot \text{K}^{-1}$				
TBU	$65.9 \pm 0.7$	$127.5 \pm 1.3$	$37.1 \pm 0.4$	$90.4 \pm 0.9$	$42.4 \pm 0.9$
ME	$47.0 \pm 0.5$	$109.3 \pm 1.1$	$27.6 \pm 0.3$	$81.7 \pm 0.8$	$65.4 \pm 0.9$

To calculate standard sublimation enthalpies of tetrazole derivatives modified electrostatic potential model was proposed. To train and test model a dataset of 44 CHN organic compounds was divided into training and test sets in a ratio of 4:1. The search for the optimal feature space was performed using correlation analysis and exhaustive feature selection, which was done by optimization of mean MSE over k-folds cross-validation. Molecular surface properties were calculated using DFT/B3LYP/6-31G+(2df,p) level of theory. The final parametric equation is:

$$\Delta_{\text{sub}} H_{298}^0 = 1.535 \cdot 10^{-4} \cdot (SA)^2 + 1.274 \cdot (\sigma_{\text{tot}}^2 \cdot \nu)^{0.5} + 4.147 \cdot 10^{-3} \cdot \Pi \cdot V + 10.41 \cdot \rho - 0.2069 \cdot V_s^2 - 11.08$$

were  $SA$  – the volume of molecular surface,  $\text{\AA}^2$ ;  $\sigma_{\text{tot}}^2$  – the degree of variability of the potential on the molecular surface,  $\text{kcal}^2 \cdot \text{mol}^{-2}$ ;  $\nu$  – a measure of the balance between positive and negative extrema on the molecular surface;  $\Pi$  – local polarity measure,  $\text{kcal} \cdot \text{mol}^{-1}$ ;  $V$  – molecular volume,  $\text{\AA}^3$ ;  $\rho$  – estimated density,  $\text{g} \cdot \text{cm}^{-3}$ ;  $V_s$  – average value of the potential at the molecular surface,  $\text{kcal} \cdot \text{mol}^{-1}$ .

The RMSE and MAE for training and test sets are 1.65 and 2.1, 1.32 and 1.37  $\text{kcal} \cdot \text{mol}^{-1}$  respectively. Adjusted  $R^2$  for training set was calculated to be 0.72. The maximum deviations for test and training splits are 4.57 and 4.09  $\text{kcal} \cdot \text{mol}^{-1}$ . According to k-folds cross-validation the RMSE and MAE of proposed model are 1.97 and 1.62  $\text{kcal} \cdot \text{mol}^{-1}$  respectively. To substantiate the possibility of using the obtained model for calculating the standard sublimations of TBU and ME the principal component analysis was used. According to the proposed parametric equation the standard sublimation enthalpies of TBU and ME at  $T = 298.15$  K were calculated to be  $28.6 \pm 2.1$  and  $24.1 \pm 2.1$   $\text{kcal} \cdot \text{mol}^{-1}$  respectively. Corresponding values of the standard enthalpies of formation of TBU and ME in crystalline state are  $13.8 \pm 2.3$  and  $41.3 \pm 2.3$   $\text{kcal} \cdot \text{mol}^{-1}$  respectively.

### References

- [1] Budevich V.A., Voitekhovich S.V. *Belstein J. Org. Chem.* **2021**, *17*, 385–395.  
[2] Curtiss L.A., Redfern P.C. *J.Chem.Phys.* **2007**, *126*, 84108.

Acknowledgements. This work was supported by State Program of Scientific Investigations «Chemical processes, reagents and technologies, bioregulators and bioorganic chemistry» (project No 2.1.1)

*Zolotovskiy K.A.<sup>1</sup>, Petrov A.V.<sup>1</sup>, Toikka A.M.<sup>1</sup>*

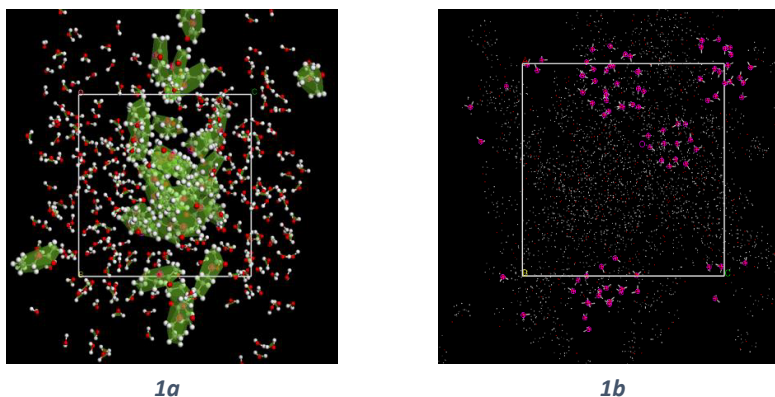
<sup>1</sup>Saint Petersburg State University, Saint Petersburg, Russia

Student

[NeoRam1@yandex.ru](mailto:NeoRam1@yandex.ru)

The conditions of stability of heterogeneous systems are the central place in classical and modern chemical thermodynamics. The general formulation of these conditions applies to both absolutely stable and metastable states. Indeed, a separate formulation for these two types of equilibrium requires knowledge of the state diagram and general conclusions cannot be obtained (see e.g. [1]). Accordingly, the calculation of the location of binodals, as the boundary between stable and metastable states, faces a lot of difficulties, and this task requires the use of model approaches. This problem is connected with a set of other tasks of the theory of phase transitions including molecular dynamic simulation. On the other hand the limit of absolute stability / instability has a clear mathematical formulation and can be presented in some equivalent forms [2]. In thermodynamics this border is determined as a spinodal. Depending on the number of components it may be spinodal curve, spinodal surface or spinodal manifold. However, the experimental determination of the spinodal location is also a complex procedure, since, as a rule, the loss of stability of the system, the spinodal decomposition occurs before reaching the spinodal itself. Thus, the problem of analyzing and determining the boundary of absolute stability remains relevant, including in the light of the need to fully characterize the structure of state diagrams.

In recent years, a number of studies have been carried out on the analysis of the spinodal and its location using molecular dynamics (MD) simulation. In particular, spinodals in vapor–liquid systems were considered, e.g. in [3]. In this work, the spinodal estimation (for pure substances) was carried out on the basis of molecular dynamic simulation using the density profile of the vapor–liquid interface. In our work we also used the density as one of the main factors but the objects of the studies were binary systems propyl acetate – water and ethyl propionate – water with liquid phase splitting. Thus we consider the spinodals in liquid-liquid systems. The MD permitted to consider changes and singularities in both density and self-diffusion. Materials Studio and GROMACS software had been used. Models of the fluid states of propyl acetate and ethyl propionate that correctly describe the density and diffusion coefficients by the MD method are developed. The Figures 1 and 2 demonstrate some results for propyl acetate – water systems.



**Figure 1.** Propyl acetate (green) and water (red/white) associated molecules in the MD cell: 1a - 10, 1b – 80 mol % of ester (dots – propyl acetate molecules).

The analysis of the radial distribution functions allowed us to obtain results that are sufficiently (qualitative) consistent with the available estimated data for the spinodal (experiment or calculation using the NRTL model). The report also discusses the prospects for the development of methods for evaluating the parameters of spinodal and stability of fluid systems based on MD.

#### References

- [1] Munster A. *Chemische Thermodynamik*, Akademie-Verlag, Berlin, **1969**.
- [2] Gromov D., Toikka A. *Entropy* **2020**, 22, 1113.
- [3] Imre A.R., Kraska T. *Fluid Phase Equilibria* **2009**, 284, 31–37.

Acknowledgements. Authors are grateful to Russian Foundation for Basic Research (project No 19-03-00375) for the support of this study.



# **INORGANIC AND ORGANOMETALLIC CHEMISTRY**

# STRUCTURE AND SYNTHESIS OF COBALT(II)-ORGANIC FRAMEWORKS WITH 1,4-DIAZABICYCLO[2.2.2]OCTANE N,N'-DIOXIDE BRIDGE.

*Abasheeva K.D.<sup>1,2</sup>, Demakov P.A.<sup>1</sup>*

<sup>1</sup>Nikolaev Institute of Inorganic Chemistry SB RAS, Akad. Lavrentieva 3, Novosibirsk, Russia

<sup>2</sup>Novosibirsk State University, Pirogova 1, Novosibirsk, Russia

Student

[k.abasheeva@g.nsu.ru](mailto:k.abasheeva@g.nsu.ru)

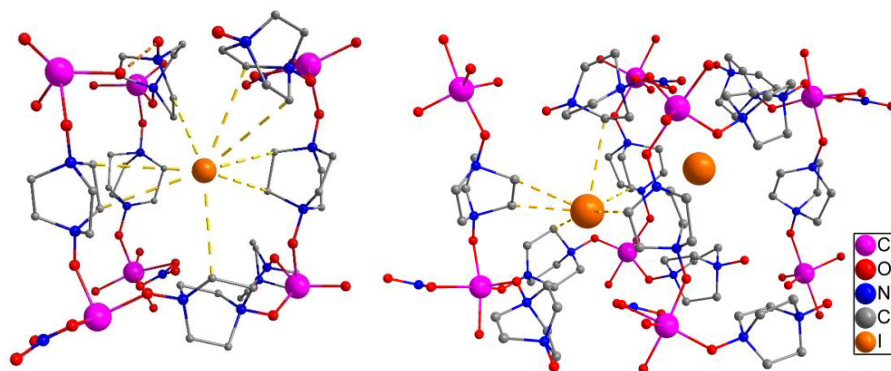
Metal-organic frameworks (MOFs) are constructed from metal ions coordinated by organic linkers. Due to their highly regular crystal structure with the large cavities possible, this class of compounds has a great potential applications in catalysis, sorption, chemical sensors, etc.

This work is devoted to the synthesis of compounds based on cobalt(II) and 1,4-diazabicyclo[2.2.2]octane N,N'-dioxide (odabco) – a rare ligand for coordination chemistry, interesting for its conformational lability and electroneutrality, which makes it possible to design cationic MOFs purposefully [1]. The combination of odabco with the magnetic and redox-active Co(II) ion uncovers a great variety of multifunctional or stimuli-responsive materials. The possibility of the torsion angle Co-O<sub>odabco</sub>-O<sub>odabco</sub>-Co change almost in the 0°...180° range makes the structure of the product easily tuned by synthetic conditions.

A chain-like acetate-containing coordination polymer [Co<sub>3</sub>(odabco)<sub>2</sub>(OAc)<sub>6</sub>] (**1**; OAc<sup>-</sup> = acetate) was synthesized in the mixture of DMF and AcOH at 80°C. On the contrary, a two-dimensional coordination polymer [Co<sub>2</sub>(OAc)<sub>2</sub>(odabco)<sub>3</sub>](NO<sub>3</sub>)<sub>2</sub> (**2**) was obtained in DMA at 120°C. Thus, a temperature and solvent composition affect the structure of the forming metal-organic framework.

A 3D metal-organic framework [Co(odabco)<sub>3</sub>](NO<sub>3</sub>)<sub>2</sub> (**3**) was obtained in the mixture of DMF and water, slightly acidified by HNO<sub>3</sub>. Increasing the acid concentration by one and a half times in the similar synthetic system leads to one-dimensional MOF [Co(Hodabco)<sub>2</sub>(odabco)<sub>3</sub>](NO<sub>3</sub>)<sub>4</sub> (**4**), which contains partially protonated and, thus, non-bridging odabco ligands. Therefore, the acidity of the reaction mixture shows the reasonable impact on the structure of the product.

A layered Co(II) formate [Co(H<sub>2</sub>O)<sub>2</sub>(HCOO)<sub>2</sub>]-odabco (**5**) was crystallized with the high yield from the acidified mixture of DMF and H<sub>2</sub>O at 70°C. Odabco molecules in this structure are not coordinated, while HCOO-ligands are formed during the hydrolysis of the solvent. Increasing the concentrations of reagents twice while fixing the rest of synthetic parameters gives a three-dimensional [Co<sub>2</sub>(odabco)<sub>5</sub>(H<sub>2</sub>O)(NO<sub>3</sub>)](NO<sub>3</sub>)<sub>3</sub>·3.65H<sub>2</sub>O (**6**) also with the high yield. This example shows a remarkable effect of the reactant concentrations on the structure and composition of odabco-based MOF. The last compound **6** contains large channels with a size of 4 × 6 Å<sup>2</sup>, in which the anion exchange is possible. Several experiments on environmental pollutants adsorption by **6** were performed. For example, a full substitution of guest nitrates by iodide-anion was achieved, and the corresponding adduct [Co<sub>2</sub>(odabco)<sub>5</sub>(H<sub>2</sub>O)(NO<sub>3</sub>)]I<sub>3</sub>·1.5H<sub>2</sub>O (**6-I**) was successfully characterized by single-crystal XRD.



**Figure 1.** Localization of iodides in cavities in **6**. Dotted lines indicate Co<sub>odabco</sub>-I distances of less than 4.1 Å.

## References

[1]. Chen L., Ji Q., Wang, X. Pan Q., Cao X., Xu G. *CrystEngComm*, **2017**, *19*(39), 5907-5914.

Acknowledgements. This work was supported by Russian Foundation for Basic Research (project No 19-43-543016).

# SPECTROSCOPY STUDY OF ORGANOMETALLIC COMPOUNDS BASED ON THE DIPYRRROMETHENES WITH P-AND D-ELEMENTS

*Aksenova Iu.V.*<sup>1</sup>, *Kuznetsova R.T.*<sup>1</sup>, *Antina E.V.*<sup>2</sup>, *Berezin M.B.*<sup>2</sup>

<sup>1</sup>National Research Tomsk State University, Tomsk, Russia

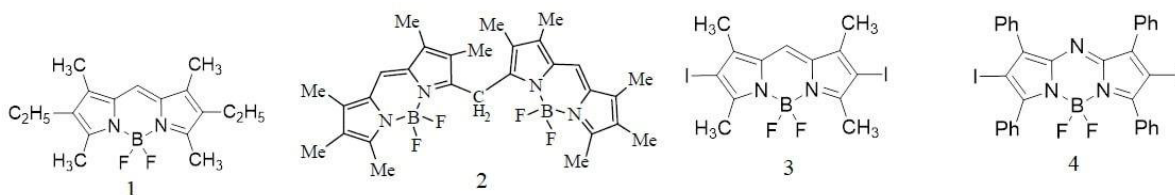
<sup>2</sup>G.A. Krestov Institute of Solution Chemistry of the RAS, Ivanovo, Russia

Young Scientist

[juliya1711@rambler.ru](mailto:juliya1711@rambler.ru)

The active research of dipyrromethene compounds is due to the broad prospects of their application in specific high-tech devices acting as fluorescent labels, optical sensors, probes, and photosensitive cells. The most promising representatives of this family are boron fluoride complexes of dipyrromethenes (BODIPY). Active laser media created on their basis (PM567, PM597) are characterized by intense radiation in the visible region of the spectrum and are successfully produced by a number of commercial firms. Nevertheless, in numerous publications mainly synthesis techniques are described, while there are not enough works on studying the relationship between structure and properties, which significantly complicates their application in other modern technologies. In this regard, the purpose of this work is to spectroscopically study the photoprocesses occurring in dipyrromethene complexes with different structures during their interaction with optical radiation in order to establish the possibility of using these compounds in modern optical devices.

The structures of some investigation compounds are shown in Figure 1. These complexes were synthesized in Institute of Solution Chemistry of the RAS (Ivanovo). The structure of complexes is confirmed by elemental and chromatography analysis [1]. Spectral-luminescent characteristics measured on spectrometer CM2203 according to standard procedures. Fluorescence, phosphorescence, luminescence excitation and emission lifetimes in the frozen (77 K) non-degassed ethanol were measured by the spectrometer Cary Eclipse. Laser experiments were carried out by the second and third harmonic of Nd:YAG laser.



**Figure 1.** Structural formulas of coordination complexes of dipyrromethenes.

The results obtained on the study of spectroscopic and lasing properties indicate the possibility of creating laser active media based on the studied alkyl BODIPY (1) with high photostability and lasing efficiency [2]. Binuclear bis (alkyl-substituted) BF<sub>2</sub>-dipyrromethenates (2) exhibit a temperature dependence of the fluorescence intensity, which can be used in the development of optical sensors to determine the temperature in the range of 300-80K [3].

The introduction of halogen atoms into the dipyrromethene ligand decreases the fluorescence efficiency and leads to the appearance of phosphorescence due to an increase in the yield of intersystem crossing by the “heavy atom” mechanism, which makes it possible to use such complexes to create sensory and photosensitizing media for singlet oxygen [2]. The use of Zn (II) and Cd (II) and ligands with meso-aza-substitution as a complexing agent increases the efficiency of nonradiative processes and the yield of triplets, decreases the lifetime of excited states, and increases molecular photostability. The quantum yield of phototransformations for the studied compounds upon irradiation of the second (532 nm) and third (355 nm) harmonics of Nd:YAG laser radiation is on the order of 10<sup>-5</sup>, which will make it possible to successfully use these compounds in the optical devices.

## References

- [1] Antina E.V., Berezin M.B., Dudina N.A., Burkova S.L., Nikonova A.Yu. *J. Inorg. Chem.* **2014**, 59, 1187–1194
- [2] Kuznetsova R.T., Aksenova Iu.V., Prokopenko A.A. et al. *J. Mol. Liq.* **2019**, 278, 5–11
- [3] Aksenova Iu., Prokopenko A., Kuznetsova R. et al. *IOP Conf. Ser: Mater. Sci. Eng.* **2019**, 597, 012003

Acknowledgements. This work was supported by the Russian Science Foundation (project No 21-73-00073).

## LOW-TEMPERATURE PHASE FORMATION IN THE BaF<sub>2</sub>–LaF<sub>3</sub> SYSTEM

*Alexandrov A.A.*<sup>1,2</sup>, *Bragina A.G.*<sup>3</sup>, *Tsygankova M.V.*<sup>3</sup>, *Fedorov P.P.*<sup>1</sup>, *Ivanov V.K.*<sup>2</sup>

<sup>1</sup>Prokhorov General Physics Institute of the Russian Academy of Sciences, Moscow, Russia

<sup>2</sup>Kurnakov Institute of General and Inorganic Chemistry RAS, Moscow, Russia

<sup>3</sup>MIREA — Russian Technological University, Moscow, Russia

PhD student

[alexandrov1996@yandex.ru](mailto:alexandrov1996@yandex.ru)

Inorganic fluorides have got a lot of applications due to their unique properties. Solid solutions in the system BaF<sub>2</sub>–LaF<sub>3</sub> are known as solid electrolytes for fluoride ion batteries. They are operated in non-ambient conditions which range of working temperatures is about 300 °C. Understanding the behavior of the system at working temperatures of such batteries is of a great interest.

Phase diagram of the system BaF<sub>2</sub>–LaF<sub>3</sub> is presented in work [1]. There are three areas on the diagram. Two of them are related to solid solutions that occur in the system with compositions that can be written as Ba<sub>1-x</sub>La<sub>x</sub>F<sub>2+x</sub> ( $x \leq 0.52$ ) which has a fluorite-related structure with Fm  $\bar{3}$  m space group (s.g.) and La<sub>1-y</sub>Ba<sub>y</sub>F<sub>3-y</sub> ( $y \leq 0.14$ ) which has tysonite-related structure with P  $\bar{3}$  c1 s.g. The third one is a two-phase area which is a mixture of above mentioned solid solutions.

In present work we applied flux-assisted method [2] to synthesize samples. Sodium nitrate is used as a flux and sodium fluoride as a fluorinating agent. Typical reaction can be described by following equation:



All samples were obtained with 5 fold molar excess of the fluorinating agent and 10 fold molar excess of the flux with different exposure time. Synthesis temperatures were varied between 350 °C to 450 °C. Samples were characterized by X-ray powder diffraction phase analysis (Bruker D8 Advanced diffractometer CuK $\alpha$  radiation), scanning electron microscopy (Carl Zeiss NVision 40) equipped with an prefix for energy dispersive X-ray analysis (Oxford Instruments XMAX).

We have synthesized two series of samples at 350 °C and 450 °C and adjusted lanthanum fluoride content with step of 10 % mol. to investigate the phase formation. When the nominal lanthanum content is under 40 % mol. two cubic phases are presented in the sample. There are pure BaF<sub>2</sub> and fluorite-related solid solution according to calculated cell parameters. When the nominal content of LaF<sub>3</sub> is more than 50 % there are also two phases in the sample. One of them is fluorite-based solid solution and second is pure LaF<sub>3</sub>. No tysonite-related solid solution is formed.

Also effect of exposure time on phase composition has been studied. According to experimental data it is established that only 60 minutes are needed to reach the equilibrium at 450 °C.

### References

- [1] Sobolev B.P., Tkachenko N.L. *J. Less Common Metals*. **1982**, 85, 155-170.  
[2] Fedorov P., Mayakova M., Alexandrov A., et al. *Inorganics* **2018**, 6(2), 38.

Acknowledgements. Mayakova M.N., Kuznetsov S.V., Voronov V.V., Baranchikov A.E.



*Alferova D.A.<sup>1</sup>, Cheremisina O.V.<sup>1</sup>*

<sup>1</sup>Saint Petersburg Mining University, Saint Petersburg, Russia

Student

[AlferovaDasha@yandex.ru](mailto:AlferovaDasha@yandex.ru)

According to the European Committee, Rare Earth Elements (REEs) are critical for the industry. The main global supplier of REEs is the People's Republic of China, with a global market share of approximately 70% [1]. The Russian Federation has a strategic reserve of a valuable resource contained in the depths of the Kola Peninsula in the form of fluorapatite and in the product of its processing, which is industrial phosphoric acid [2].

The extraction of REEs from phosphoric acid solutions has specific features, which are high acidity of solutions, low content of target components, and the presence of iron and titanium impurities. The most effective method of metal recovery and separation is solvent extraction using di-(2-Ethylhexyl)phosphoric acid (D2EHPA) as an extractant.

As well as the valuable component, impurity elements (iron and titanium) pass into the organic phase, interact with the extractant and reduce its capacity by the REEs. To get a pure solution, it is required to implement the stage of the purification from Fe and Ti. Previously, a method for isolating an extract of rare earth elements with an iron content of less than 0.1% was obtained [3].

The purpose of this research was to find an effective solution for obtaining a REEs extract that does not contain titanium impurities. To accomplish the task, it was necessary to describe the chemical reaction of titanium re-extraction, select a re-extractant, determine the effective re-extraction parameters, and obtain individual metal compounds.

As a re-extractant, oxalic acid was chosen, which forms strong complexes with titanium ions. To determine the effective purification parameters, the dependences of the degree of titanium recovery on the concentration of oxalic acid, the time of the process, the mixing rates, the relative content of the aqueous and organic phases and the temperature were studied. The results of the experiments are presented in Table 1.

**Table 1.** Effective parameters of purification of REEs extract from titanium impurity

Parameters	Numerical value	Units of measurement
D2EHPA concentration in kerosene	50	%
C <sub>2</sub> H <sub>2</sub> O <sub>4</sub> concentration	0.25	Mol/l
V <sub>org</sub> /V <sub>aq</sub> phase ratio	0.5	

According to the tangent of the slope angle of the logarithm of the degree of approximation to equilibrium as a function of time, it was found that an increase in temperature by 20 °C only increases the speed of the process by 1.5 times, which characterizes the process in the diffusion region, which corresponds to the calculated value of the activation energy equal to 2.8±0.4 kJ.

The enthalpy of the reaction of titanium with D2EHPA is determined based on the obtained metal distribution coefficients between the aqueous and organic phases, and equal to 16.5±0.6 kJ/mol. The reaction is endothermic, i.e., it proceeds with the absorption of heat. Thus, an increase in the temperature in the reaction zone shifts the equilibrium in the direction of obtaining reaction products.

To increase the degree of purification of solutions from titanium, a multistage counter-current contact of the extract and oxalic acid is used. The higher the number of stages of oxalic acid re-extraction, the higher the degree of titanium recovery. The optimum is reached after 14 stages when the mass fraction of titanium (relative to REEs) is less than 0.9%, and its concentration in the organic phase is reduced by more than 10 times with the REM content unchanged. Moreover, the removal of impurity metals makes it possible to increase the capacity of the extractant for REEs by 2-2.5 times.

Based on the obtained data, a scheme for the extraction and separation of REEs was compiled. Its products are individual purified compounds with the content of the target component from 83 to 95% and the content of non-rare earth impurities at the ppm level.

#### References

- [1] Critical Raw Materials Resilience: Charting a Path towards greater Security and Sustainability COM/2020/474 URL: <https://eur-lex.europa.eu/legal-content/EN/TXT/?uri=CELEX:52020DC0474>  
 [2] U.S. Geological Survey. URL: <https://pubs.er.usgs.gov/publication/ofr20191023A>  
 [3] Cheremisina O.V. *Zapiski Gornogo Instituta*, **2015**, 214, 39–50.

Acknowledgements. This work was supported by the Russian Science Foundation (project No 19-19-00377).

## GOLD(I) NUCLEOPHILICITY TOWARD HALOMETHANES

*Aliyarova I.S.*<sup>1,2</sup>, *Ivanov D.M.*<sup>1,2</sup>

<sup>1</sup> Institute of Chemistry, Saint Petersburg State University, Saint Petersburg 199034, Russia

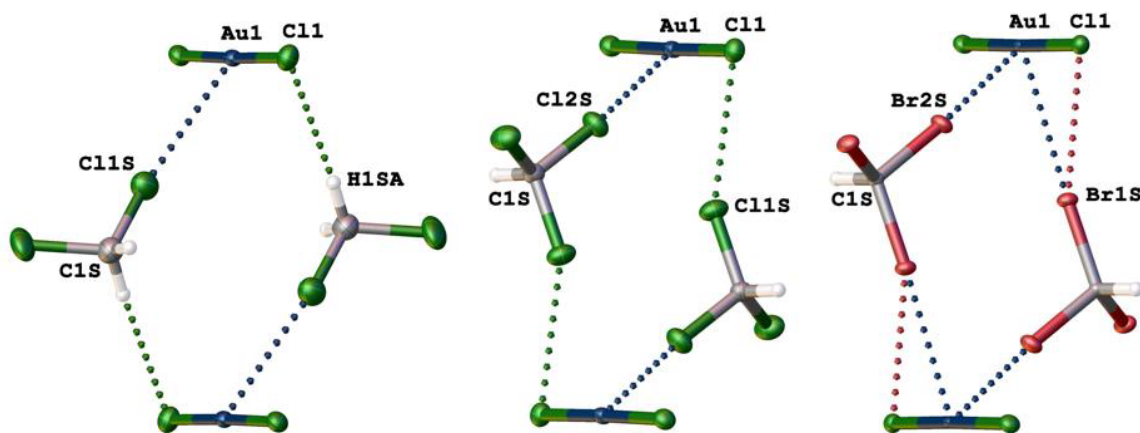
<sup>2</sup> Tomsk Polytechnic University, Tomsk 634034, Russia

PhD Student

[st072374@student.spbu.ru](mailto:st072374@student.spbu.ru)

Halogen bonding (XB) is one of the types of non-covalent interactions actively studied in recent years. XB is an electrostatic interaction between a nucleophilic, electron-rich center and a region of positive potential ( $\sigma$ -hole) that exists on the surface of a covalently bonded halogen atom [1]. Usually as XB acceptors can be anions,  $\pi$ -systems and atoms with lone electron pairs, however, as shown in the work [2], a metal atom can also act as a nucleophilic center.

In this work cocrystals of [PPN][AuCl<sub>2</sub>] ([PPN]<sup>+</sup> - bis(triphenylphosphine)iminium cation, (C<sub>6</sub>H<sub>5</sub>)<sub>3</sub>P)<sub>2</sub>N<sup>+</sup>) with halomethanes were studied. In all cases the halomethane...chloride and halomethane...gold(I) interactions were detected. The presence and nature of the contacts were confirmed by X-ray diffraction data and DFT calculations.



**Figure 1.** Cocrystals of [PPN][AuCl<sub>2</sub>] with halogenmethanes.

### References

- [1] G. R. Desiraju, P. S. Ho, L. Kloo, A. C. Legon, R. Marquardt, P. Metrangolo, P. Politzer, G. Resnati, K. Rissanen. *Pure Appl. Chem.* **2013**, *85*, 1711–1713.  
[2] S.V. Baykov, U. Dabranskaya, D.M. Ivanov, A.S. Novikov, V.P. Boyarskiy. *Cryst. Growth Des.* **2018**, *18*, 5973–5980.

**Acknowledgements.** This work was supported by the Russian Foundation for Basic Research (project 20-33-90029; synthetic and X-ray diffraction experiments) and the Russian Science Foundation (project 20-13-00144; theoretical calculations).

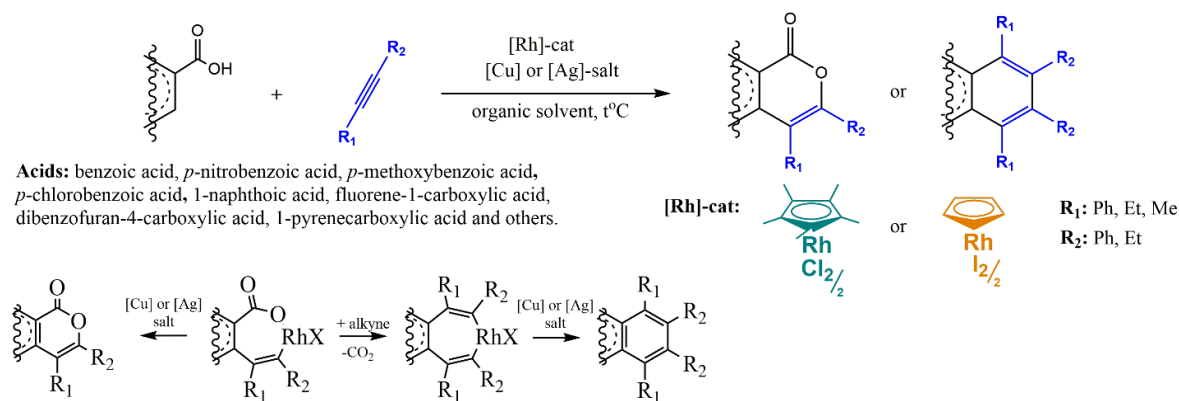
# EXPANSION OF SUBSTRATE SCOPE FOR SYNTHESIS OF POLYCYCLIC AROMATIC HYDROCARBONS VIA C–H ACTIVATION REACTIONS

*Arsenov M.A.*<sup>1</sup>, *Loginov D.A.*<sup>1</sup>

<sup>1</sup>A. N. Nesmeyanov Institute of Organoelement Compounds, Russian Academy of Sciences, Moscow, Russia  
Student  
[arsmikhail33@gmail.com](mailto:arsmikhail33@gmail.com)

The development of atom-effective and energy-efficient approaches to the creation of carbon-carbon bonds is one of the most important tasks for organic synthesis. In particular, catalytic reactions (including C-H activation) are efficient methods for the synthesis of molecules with a complex structure from easily available starting compounds. The recent discovery of the directing group assisted C-H activation has triggered a rapid development of this field. In the case of aromatic compounds, substituents with donor atoms (e. g. pyrazole, carboxylic, and ketone functions) act as directing groups to provide high selectivity of C-H activation in *ortho*-position under chelation-assistance mechanism [1]. Inclusion of alkenes or alkynes in these reactions proved to be efficient approach to synthesis of a wide range of heterocycles with various biological and optical properties.

The reaction of the oxidative coupling of aromatic carboxylic acids with acetylenes is an efficient direct approach to isocoumarin and naphthalene derivatives, which are of great interest for application in the development of photoactive materials. Earlier, we have found that selectivity of the reaction is strongly dependent on the nature of the supporting ligand at the rhodium atom [2]. For example, the pentamethyl derivative [Cp\**Rh*Cl<sub>2</sub>]<sub>2</sub> predominantly gives isocoumarins, while the non-methylated complex [Cp*Rh*Cl<sub>2</sub>]<sub>n</sub> produces naphthalene derivatives (Figure 1). However, the disadvantage of the reaction is low reactivity of carboxylic acids with electron-withdrawing groups (such as NO<sub>2</sub>, CF<sub>3</sub>, COOH, etc.)



**Figure 1.** Synthesis of isocoumarin and naphthalene derivatives.

In the present work, we perform comprehensive screening of solvents and additives to optimize the reaction conditions for electron-deficient carboxylic acids. With the optimized conditions in hand, we were able to expand the substrate scope and synthesize novel isocoumarins and PAHs. The mechanism of catalytic reactions as well as photoactive properties of compounds prepared will be also discussed.

## References

- [1] C. Sambigioglio, D. Schönbauer, R. Blicke, T. Dao-Huy, G. Pototschnig, P. Schaaf, T. Wiesinger, M.F. Zia, J. Wencel-Delord, T. Besset, B.U.W. Maes, M. Schnürch, *Chem. Soc. Rev.*, **2018**, *47*(17), 6603-6743
- [2] A.P. Molotkov, M.A. Arsenov, D.A. Kapustin, D.V. Muratov, N.E. Shepel', Y.V. Fedorov, A.F. Smol'yakov, E.I. Knyazeva, D.A. Lypenko, A.V. Dmitriev, A.E. Aleksandrov, E.I. Maltsev, D.A. Loginov, *ChemPlusChem*, **2020**, *85*(2), 334-345

Acknowledgements. This work was supported by the Russian Science Foundation (Grant No. 17-73-30036).

REACTIVITY OF LOW-VALENT DERIVATIVES OF GROUP 14 ELEMENTS  
BEARING O-AMIDOPHENOLATE LIGANDS

*Arsenyeva K.V.*<sup>1</sup>, *Piskunov A.V.*<sup>1</sup>, *Chegerev M.G.*<sup>2</sup>

<sup>1</sup> G.A. Razuvaev Institute of Organometallic Chemistry, Nizhny Novgorod, Russia.

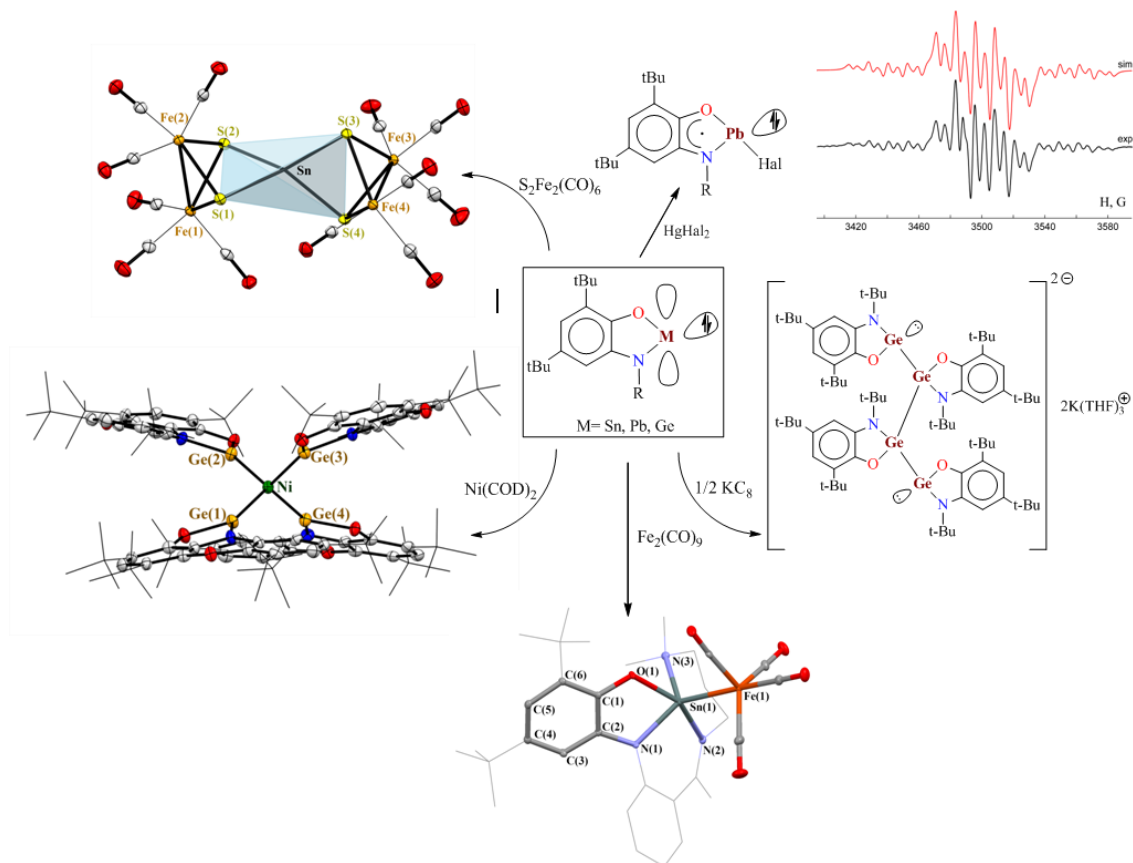
<sup>2</sup> Southern Scientific Center of Russian Academy of Sciences, Rostov on Don, Russia.

PhD Student

[kselenia22@gmail.com](mailto:kselenia22@gmail.com)

The interest in the chemistry of the heavier analogs of carbene has not decreased over the past years. At present, a lot of stable metallylenes derived from different heterocycles have been described. The N,N-heterocyclic analogs of carbenes based on various diimines are the most studied today. But there are practically no data concerning O,N-heterocyclic metallylenes.

This report presents the synthesis of new O,N-heterocyclic germlylenes, stannylenes, and plumbylenes bearing N-(R)-substituted o-amidophenolate backbone. o-Aminophenoles, being redox-active, can be used as reservoirs of electrons for bond-making and bond-breaking reactions. They can support the multi-electron changes required to promote group- or atom-transfer processes. Thus, introducing such a ligand system to the heavier carbene analog center allows imparting new redox reactivity to the metallylenes. The report discusses the molecular and electronic structure of low-valent germanium, tin, and lead derivatives containing various di- and tetradentate o-amidophenolate ligands. X-ray analysis of Ge(II) o-amidophenolates shows that they are monomeric in the solid-state. This behavior is in contrast to the situation observed for related stannylenes and plumbylenes. The appearance of the aromatic system in the five-membered chelate cycle of O,N-heterocyclic germlylenes, and associated compounds is shown. The presence of several reaction centers leads to various reductive or oxidative transformations of the studied compounds. Reactions in which O,N-heterocyclic germlylenes, stannylenes, and plumbylenes are involved as acids or Lewis bases are considered.



**Figure 1.** The reactivity of new metallylenes.

Acknowledgments. This work was supported by the Russian Science Foundation (Grant 17-13-01428p)

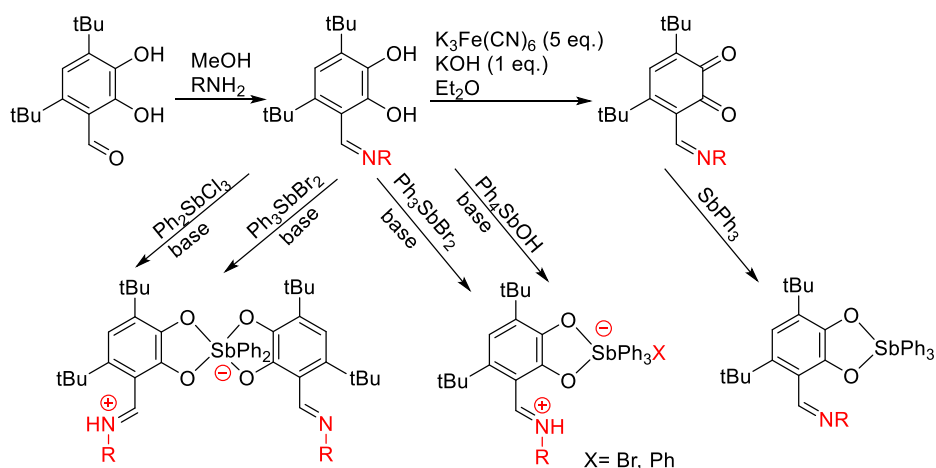
<sup>1</sup> Lobachevsky State University, Nizhni Novgorod, Russia<sup>2</sup> Razuvaev Institute of Organometallic Chemistry, Nizhni Novgorod, Russia

PhD student

[tata1525@mail.ru](mailto:tata1525@mail.ru)

The chemistry of metal complexes based on redox-active ligands has been intensively developed over the last several years. More and more unusual chemical transformations are becoming available because of the ability of the ligands to undergo reversible redox transformations within the metal coordination sphere. Variations in the substituents in the ligand have a significant effect on both the redox properties of catechol complexes [1–2] and their chemical behaviour, biochemical activity [3]. The five-coordinated antimony catecholates are of particular interest, due to their ability to further coordinate various donor substituents.

In our work, the influence of the ligands form with the aldimine fragment on the complexation of antimony catecholate complexes was shown (Figure 1).



**Figure 1.** Synthesis of catechols, quinones and antimony complexes

It was found that when using catechol by the substitution reaction in the presence of bases, six-coordination complexes of antimony are formed. When carrying out reactions with catechols, the products of symmetrisation catecholates complexes were found, which were obtained by counter synthesis. When using the oxidized form of ligands (o-quinones), five-coordination catecholates complexes of triphenylantimony (V) were isolated by the oxidative addition reaction.

### References

- [1] Poddel'sky A.I. et al. *Russ. Chem. Bull.* **2009**, 58, 532–537  
 [2] Smolyaninov I.V. et al. *Russ. J. Coord. Chem.* **2010**, 36, 644–650  
 [3] Smolyaninov I.V. et al. *J. Organomet. Chem.* **2011**, 696, 2611–2620

**Acknowledgements.** The reported study was funded by RFBR, project number 19-33-90067. The spectroscopic investigations of compounds were performed in accordance with state assignment of IOMC RAS. The spectroscopic and X-ray structural investigations were performed in the Analytical centre of IOMC RAS.

# TITRIMETRIC DETERMINATION OF METAL MASS FRACTION IN METAL-ORGANIC FRAMEWORKS COMPOUNDS

*Babitova E.S.<sup>1</sup>, Skripkin M. Yu.<sup>1</sup>*

<sup>1</sup>Saint Petersburg State University, Saint Petersburg, Russia

Student

[st064214@student.spbu.ru](mailto:st064214@student.spbu.ru)

Metal-organic frameworks are perspective objects for investigation due to their porous structure. MOFs are applied to gas adsorption, catalysis and gas separation. Identification of the composition of metal-organic frameworks is often a quite complicated task. Principal methods of identification are X-ray diffraction analysis requiring single crystals of MOF and CHNS-analysis. However, application of both methods request specific laboratory equipment. This fact determines the interest to elaboration of alternative methods of MOFs identification, among which titrimetric methods are at the top. In this work, complexometric titration used for determination of the metal mass fraction in metal-organic frameworks based on Cu<sup>2+</sup>, Zn<sup>2+</sup>, Co<sup>2+</sup> and Mg<sup>2+</sup> as a cations, trimesate, terephthalate, phthalate and 4,4'-bipyridine as a linker[1].

**Table 1.** Information of some MOFs synthesized.

Name	Cation	Linker	Solvent
NICS-4	Mg <sup>2+</sup>	trimesate	H <sub>2</sub> O, EtOH
Cutere5	Cu <sup>2+</sup>	terephthalate	H <sub>2</sub> O, DMF
HMHH-6	Cu <sup>2+</sup>	4,4'-bipyridine, terephthalate	H <sub>2</sub> O, EtOH
Zntere	Zn <sup>2+</sup>	terephthalate	H <sub>2</sub> O, DMF
B34	Co <sup>2+</sup>	4,4'-bipyridine	H <sub>2</sub> O, EtOH
CuNO3-7	Cu <sup>2+</sup>	phthalate	H <sub>2</sub> O

Wet mineralization was chosen as the method of sample decomposition. After heating with concentrated nitric acid pH was increased by ammonia buffer solution and then standard complexometric titration was applied. It shown that complexometric titration can be used to determinate the mass fraction of metal in metal-organic frameworks with Cu<sup>2+</sup>, Co<sup>2+</sup> and Mg<sup>2+</sup>.

## References

[1] Matjaž Mazaj, Tadeja Birsa *Cryst. Growth Des.* **2013**, *13*, 8, 3825–3834

## IN SEARCH OF BIOLOGICALLY ACTIVE COMPOUNDS WITH Zn<sup>2+</sup> IONS

*Baravikov D.E.*<sup>1,2</sup>, *Lutsenko I.A.*<sup>2</sup>, *Kiskin M.A.*<sup>2</sup>, *Becker O.B.*<sup>3</sup>, *Eremenko I.L.*<sup>2</sup>

<sup>1</sup> Russian University of Chemical Technology named after I.I. DI. Mendeleev, Moscow

<sup>2</sup> Institute of General and Inorganic Chemistry, N.S. Kurnakov RAS, Moscow

<sup>3</sup> Institute of General Genetics, N.I. Vavilova RAS, Moscow

Student

[dbbaravikov@gmail.com](mailto:dbbaravikov@gmail.com)

Zinc (Zn) is one of the vital elements, it takes part in all types of metabolism, is part of 7200 enzymes, it plays an important role in the synthesis and stabilization of protein and nucleic acid structures, plays an important role in the process of cell growth and division, the formation of antioxidant status as a protector of free radical reactions<sup>1, 2</sup>, etc. Recently, more and more biochemists, biologists and physicians have noted a feature when using metal-containing drugs for the treatment of tuberculosis - at relatively low concentrations (in contrast to organic drugs), a stable effect of suppressing the growth of mycobacteria is observed. Thus, the use of coordination compounds of transition metals opens up the prospect of creating a new generation of anti-tuberculosis drugs. The purpose of this work was to develop methods for the synthesis of zinc complexes with 2-furancarboxylic acid (2-HFur) and additional N-donor ligands (pyridine (Py), 2,2'-bipyridine (2,2'-bpy), 4-phenylpyridine (phpy), 2,9-dimethyl-1,10-phenanthroline (neocuproin, nec), 2,9-dimethyl-4,7-diphenyl-1,10-phenanthroline (Bathocuproin, bathcup).

Mono- [Zn(fur)<sub>2</sub>(2,2'-bpy)] (1), [Zn(fur)<sub>2</sub>(bathcup)] (2), [Zn(fur)<sub>2</sub>(nec)] (3) and binuclear complexes [Zn<sub>2</sub>(fur)<sub>4</sub>]<sub>n</sub> (4), [Zn<sub>2</sub>(fur)<sub>4</sub>(phpy)<sub>2</sub>] (5), [Zn<sub>2</sub>(fur)<sub>4</sub>(py)<sub>2</sub>] (6). All compounds were isolated as single crystals and their structure was determined by X-ray diffraction.

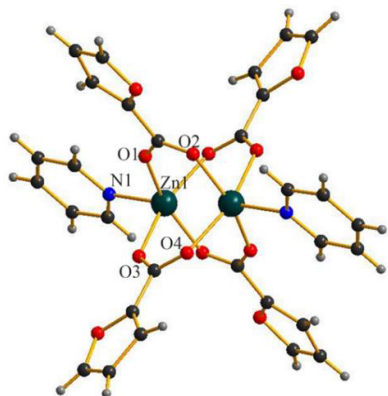


Figure 1. [Zn<sub>2</sub>(fur)<sub>4</sub>(py)<sub>2</sub>]

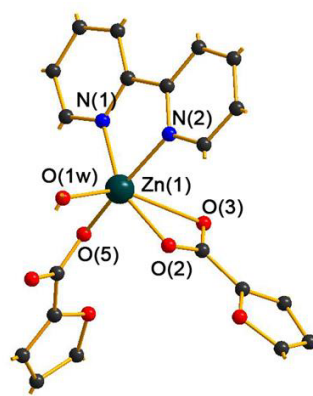


Figure 2. [Zn(fur)<sub>2</sub>(2,2'-bpy)]

The antibacterial activity of compounds 1-6 was determined in vitro against the non-pathogenic strain of *Mycobacterium smegmatis*. The *M. smegmatis* test system exhibits a higher degree of drug resistance than *M. tuberculosis*; therefore, the selection criterion is a substance concentration of <100 µg / disc. The results of the trials obtained correlated with the first-line drugs for treatment of tuberculosis with isoniazid (100 µg / disc) and rifampicin (10 µg / disc). Complexes 1-3 and 5 showed similar bioactivity (about 45 µg / disc)<sup>4, 5</sup>; the smallest 4 and 6 (about 500 mcg / disc). Thus, the tests carried out have shown that additional N-donor ligands introduced into the complex are capable of both increasing the biological activity (bipyridine) and decreasing (pyridine).

### References

[1] Kimura T., Kambe T. *Int. J. Mol. Sci.* **2016**, *1*, 336

[2] Mason J.B. Vitamins, trace minerals, and other micronutrients // L.S. Goldman, I. Andrew (Eds.). Cecil Medicine, Philadelphia: Saunders Elsevier, 2016. P. 1445–1455

[4] Lutsenko I.A., Baravikov D.Ye., Kiskin M.A. et al., *Coord. chemistry.* **2020**. 46.No. 6.P. 366-375.

[5] Lutsenko I.A., Yambulatov D.S., Kiskin M.A. et al. // *Coord. chemistry.* **2020**.46.No. 12.P. 715-722.

Acknowledgements. This work was supported by Russian Foundation for Basic Research (project No 20-13-00061).

# SYNTHESIS AND REACTIVITY OF 1,8-BIS(DIMETHYLAMINO)NAPHTHALENYL BORONIC ACIDS

*Bardakov V.G.<sup>1</sup>, Yakubenko A.A.<sup>1</sup>, Antonov A.S.<sup>1</sup>*

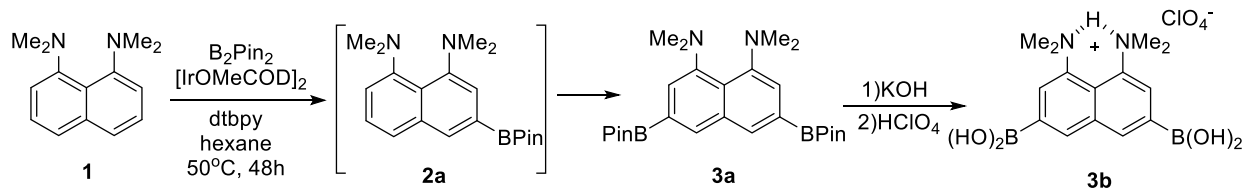
<sup>1</sup>Saint Petersburg State University, Saint Petersburg, Russia

PhD Student

[st081032@student.spbu.ru](mailto:st081032@student.spbu.ru)

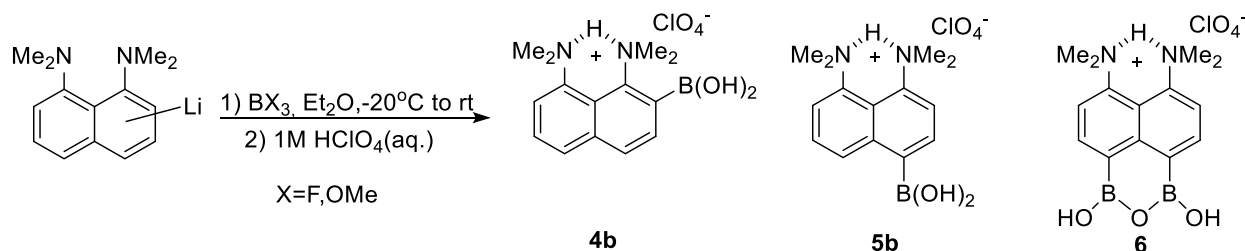
1,8-bis(dimethylamino)naphthalene (DMAN) **1**, also known as naphthalene «proton sponge» attracts the attention of researchers for many years due to its outstanding high basicity combined with low nucleophilicity. Multiple reported methods of DMAN derivatization are generally based on electrophilic substitution, while organometallic approaches are way less developed. Here we report the preparation of organoboron derivatives of DMAN – perspective precursors for the synthesis of organic superbases.

Direct iridium-catalysed borylation of DMAN **1** with B<sub>2</sub>Pin<sub>2</sub> was successfully used for the preparation of *meta*-disubstituted boronic ester **3a** and corresponding acid **3b** (Scheme 1). Second borylation occurs much faster making it impossible to obtain monoborylated derivative **2a** selectively, however, usage of the excess of B<sub>2</sub>Pin<sub>2</sub> gives **3a** with high yield and 100% selectivity.



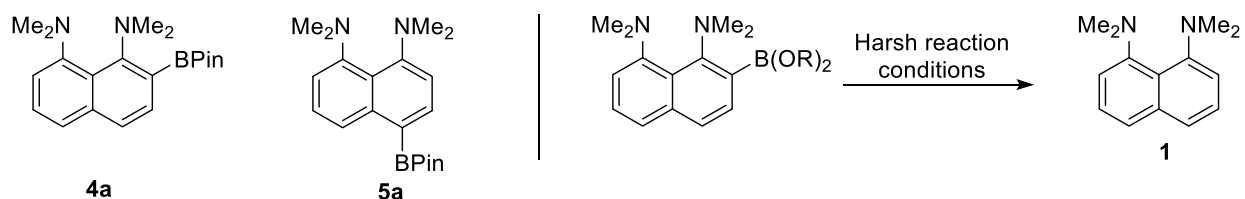
**Scheme 1.** Synthesis of *meta*-diboronic derivatives of 1,8-bis(dimethylamino)naphthalene.

*Ortho*-, *para*-monoboronic and *peri*-diboronic acids were prepared by the treatment of suitable organolithium reagent with B(OMe)<sub>3</sub> or BF<sub>3</sub> followed by hydrolysis. Noticeably, *peri*-diboronic derivative undergo spontaneous transformation into cyclic anhydride **6**. Our attempts to obtain *ortho*-diboronic acid failed due to the strong steric repulsion between B(OMe)<sub>2</sub> and NMe<sub>2</sub> groups, leading to the deborylation.



**Scheme 2.** Synthesis of *ortho*- and *para*- 1,8-bis(dimethylamino)naphthalenylboronic acids.

Esterification of obtained boronic acids with pinacol occurs smoothly leading to the formation of corresponding esters **4a** and **5a** with quantitative yield.



**Scheme 3.** *Ortho*- and *para*- 1,8-bis(dimethylamino)naphthalenylboronic pinacol esters; Deborylation of *ortho*-derivatives.

Surprisingly, under conditions of typical for arylboronic acids reactions such as Suzuki cross-coupling, halodeboronation, Chan-Lam amination, oxidative hydroxylation and Petasis borono-Mannich reaction, *para*- and *meta*-boronic acids and their esters show no reactivity. At the same time *ortho*-boronic acid undergo complete sterically facilitated deborylation due to the above mentioned repulsion of B(OMe)<sub>2</sub> and NMe<sub>2</sub> groups.

Acknowledgements. This work was supported by the Russian Science Foundation (project 18-73-00020)



# SYNTHESIS BALL-TYPE II CLAM-SHELL MAGNESIUM PHTHALOSYANINES WITH OXY-BENZENE FRAGMENTS AS A BRIDGE SUBSTITUTES AND STUDY OF FLUORESCENCE PROPERTIES

*Belikova A.A.<sup>1</sup>, Erzunov D.A.<sup>1</sup>, Vashurin A.S.<sup>1</sup>*

<sup>1</sup>Ivanovo State University of Chemistry and Technology, Ivanovo, Russia

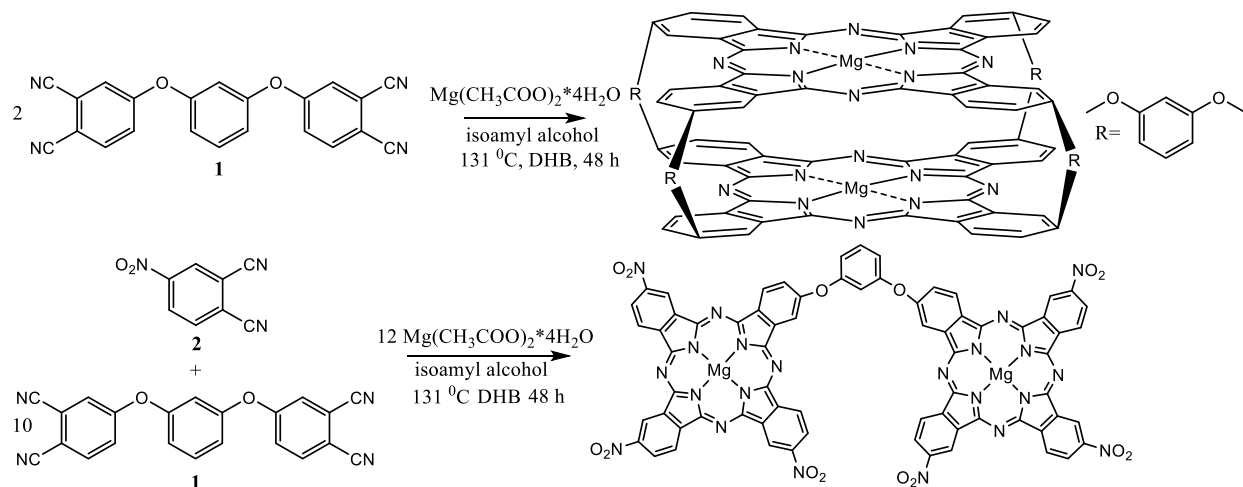
Student

[89051065598@mail.ru](mailto:89051065598@mail.ru)

Phthalocyanines have a unique structure that includes four isoindole fragments, due to which these complexes exhibit linear and nonlinear optical properties. Based on the above, compounds of this class can be used to create nonlinear optical materials that protect human eyes and optical devices from laser radiation. Compared to their monomeric counterparts, ball-type phthalocyanines show greater interaction between macro rings, which is reflected in the properties [1]. Therefore, such compounds have promising applications in semiconductors, liquid crystals, and solar cells. Compounds of this structure absorb light in the long-wave region of the spectrum, so they can be considered as promising complexes for photodynamic therapy [2]. In addition, their absorption is shifted to the red region of the spectrum, where the transparency of biological tissues is higher, which expands the therapeutic possibilities of the method. However, the compounds of this structure are prone to uncontrolled aggregation, which makes it very difficult to work with these compounds, since most studies are performed in organic and aqueous solutions. It was also demonstrated that the aggregation is significantly influenced by structural parameters of the dimers, such as relative slippage, tilting and rotation of the macrocycles, while distortions and increase in distance between the phthalocyanine planes lead to suppression of the aggregation [3].

In this work we present methods for the synthesis of phthalocyanines with complex structures, such as clam-shell and ball-type phthalocyanines, and study their fluorescent properties.

The synthesis was carried out in iso-amyl alcohol solution at the boiling temperature of the solvent using a reflux condenser. Nitriles of various structures and four-water magnesium acetate were used as starting compounds.



**Figure 1.** Synthesis ball-type and clam-shell magnesium phthalocyanines

All the compounds were isolated from the reaction mixture, purified, and their structure proved by mass spectrometry and electron absorption spectroscopy. The choice of the oxy-benzene fragment as a bridging substituent was due to the fact that in this case the benzene rings are bound flexibly by oxygen bridges, which causes their high mobility.

## References

- [1] Kakı E., Altındal A., Salih B. et al. *Dalton Trans.* **2015**, 44, 8293–8299.
- [2] Canlıca M., *Inorg. Chim. Acta.* **2020**, 511, 119830–119838.
- [3] Tolbin, A.Y., Pushkarev V.E., Sedova M.V. et al. *Spectrochim. Acta, Part A.* **2018**, 205, 335–340.

Acknowledgements. This work was supported by the Russian Science Foundation (project No 17-73-20017).

NEW TYPE OF PLANAR BINUCLEAR PHTHALOCYANINES SHARING A COMMON CARBAZOLE SPACER:  
SYNTHESIS, OPTICAL AND ELECTROCHEMICAL PROPERTIES STUDY

Belousov M.S.<sup>1</sup>, Dubinina T.V.<sup>1,2</sup>

<sup>1</sup>Lomonosov Moscow State University, Department of Chemistry, 119991 Moscow, Russian Federation

<sup>2</sup>Institute of Physiologically Active Compounds, RAS, 142432 Chernogolovka, Russian Federation

Student

[mikbelousov99@gmail.com](mailto:mikbelousov99@gmail.com)

Planar binuclear phthalocyanines are macroheterocycles of the porphyrazine family consisting of two phthalocyanine rings sharing a common aromatic spacer, thus forming a new extended system of  $\pi$ -conjugation. Absorption maxima of planar binuclear phthalocyanines are red-shifted, and they are as stable as their mononuclear analogs. Thus, such compounds are of increasing importance due to their potential use in non-linear optical and data storage devices, as laser dyes and IR-marks. Binuclear phthalocyanines sharing benzene, naphthalene or pyrazine linkers are well known. But as far as we know binuclear phthalocyanines bearing heteroaromatic bridging fragment with convenient site of modification are unrepresented in literature.

Herein we report the synthetic route to novel binuclear phthalocyanines sharing a common carbazole spacer. Initial compound - carbazole tetranitrile **1** was obtained throughout 6 step synthesis starting from ethyl acetoacetate. To increase yields of target complexes, it was then transformed to the *bis*diiminoisoindoline form, which is more reactive in statistical condensation reaction. Binuclear complexes **3-5** demonstrate an intense absorption up to 721 nm hypsochromically shifted in comparison with the earlier described planar binuclear complexes sharing common benzene and naphthalene rings.

For the series of obtained complexes **3-5** singlet oxygen quantum yields were measured in DMF using 1,3-diphenylisobenzofuran (DPBF) as a chemical <sup>1</sup>O<sub>2</sub> trap. And for binuclear phthalocyanine **3** the mechanism of photodegradation under longer irradiation time and without <sup>1</sup>O<sub>2</sub> trap was studied using MALDI TOF mass spectrometry.

At the next stage the benzyl protection group was successfully removed from 9H-carbazole moiety of complex **3**. Thus, complex **6** prospective for further structural modification via nucleophilic substitution, Ullmann-type or Buchwald-Hartwig coupling reactions was obtained.

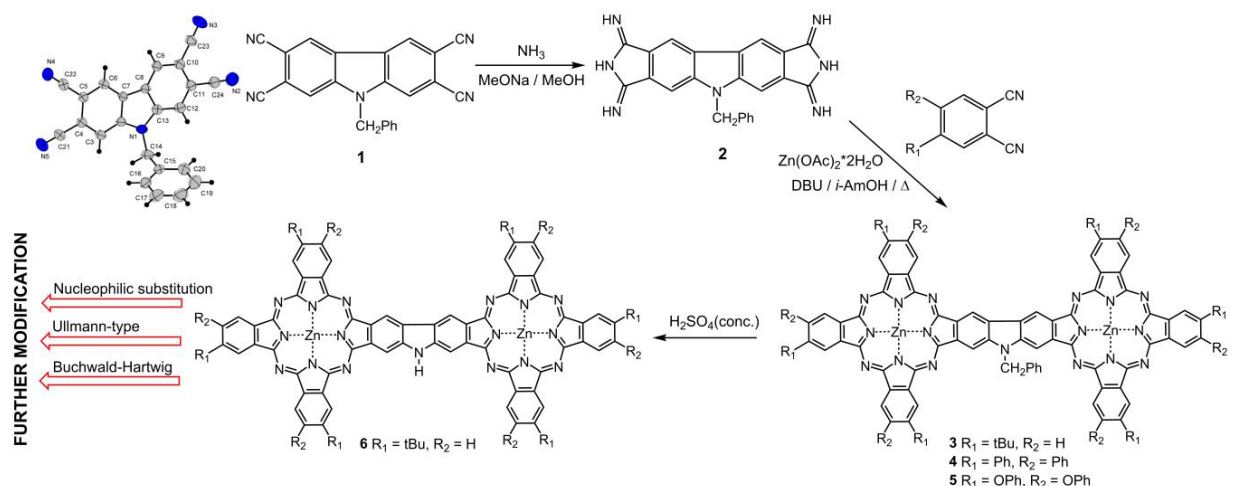


Figure 1.

Acknowledgements. This work was supported by ERA.Net RUS Plus Plasmon Electrolight and FWO funding (RFBR №18-53-76006 ERA).

# HIGH PERFORMANCE Rh/TiO<sub>2</sub> PHOTOCATALYSTS FOR HYDROGEN EVOLUTION REACTION

*Berdyugin S.<sup>1,3</sup>, Kozlova E.<sup>2</sup>, Kurenkova A.<sup>2</sup>, Gerasimov E.<sup>2</sup>, Bukhtiyarov A.<sup>2</sup>, Kolesov B.<sup>1</sup>, Yushina I.<sup>1</sup>, Vasilchenko D.<sup>1</sup>, Korenev S.<sup>1</sup>*

<sup>1</sup>Nikolaev Institute of Inorganic Chemistry SB RAS, Novosibirsk, Russia

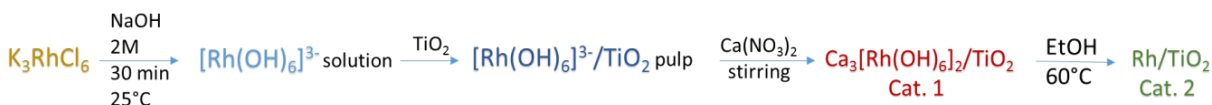
<sup>2</sup>Boreskov Institute of Catalysis, Novosibirsk, Russia

<sup>3</sup>Novosibirsk State University, Novosibirsk, Russia

PhD Student

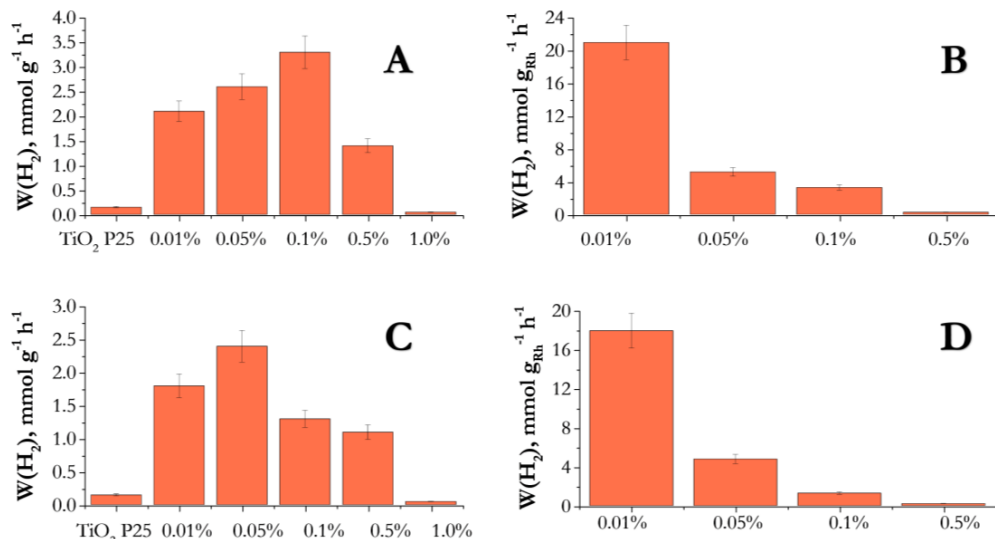
[berdyugin@niic.nsc.ru](mailto:berdyugin@niic.nsc.ru)

The new deposition method (Figure 1) of rhodium onto oxide carriers was applied to prepare Ca<sub>3</sub>[Rh(OH)<sub>6</sub>]<sub>2</sub>/TiO<sub>2</sub> (Catalyst 1) and Rh/TiO<sub>2</sub> (Catalyst 2) photocatalysts for hydrogen evolution reaction (Figure 1).



**Figure 1.** Preparation procedure of Ca<sub>3</sub>[Rh(OH)<sub>6</sub>]<sub>2</sub>/TiO<sub>2</sub> (Catalyst 1) and Rh/TiO<sub>2</sub> (Catalyst 2) photocatalysts.

Catalyst 1 consists of particles of Ca<sub>3</sub>[Rh(OH)<sub>6</sub>]<sub>2</sub> with average diameter 2.5 nm which are evenly distributed onto TiO<sub>2</sub> surface according to EDX, HAADF TEM and DRS. The treatment of Catalyst 1 with ethanol results in reduction of rhodium with the formation of 2.5 nm Rh particles. Both catalysts are active in hydrogen evolution reaction from 10% ethanol/water solution which proceeds under 380 nm irradiation (Figure 2). During the process Ca<sub>3</sub>[Rh(OH)<sub>6</sub>]<sub>2</sub> undergoes reduction to metallic rhodium, nevertheless, in such situation particles are attached to the surface of TiO<sub>2</sub> stronger than in a case of Catalyst 2 which results in higher activity of Catalyst 1 in HER. The activity of both catalysts strongly depends on rhodium loading: 1 wt.% samples are not active due to light filtering by Rh nanoparticles, the decreasing of Rh loading results in increasing of activity which maximum is achieved when rhodium loading is 0.1% for Catalyst 1 (3.3 mmol·h<sup>-1</sup>·g<sup>-1</sup>) and 0.05% for Catalyst 2 (2.4 mmol·h<sup>-1</sup>·g<sup>-1</sup>). On the other hand, the activity per rhodium loading is increasing with the decreasing of amount of metal down to 0.01 wt.% achieving 21 and 18 mol·h<sup>-1</sup>·g<sub>Rh</sub><sup>-1</sup> for Catalyst 1 and Catalyst 2 correspondingly which are order of magnitude higher than those described earlier in the literature. The cycling test showed the stability of both catalysts for at least 5 runs.



**Figure 2.** The rate of HER per gram of catalyst (A, C) and per gram of rhodium in catalyst (B, D) for Ca<sub>3</sub>[Rh(OH)<sub>6</sub>]<sub>2</sub>/TiO<sub>2</sub> (A, B) and Rh/TiO<sub>2</sub> (C, D) respectively.

Acknowledgements. B.S.N. thanks the Ministry for Science and Higher Education of the Russian Federation for the award of a fellowship of the President of the Russian Federation for young scientists.

# STUDY ON DEPOSITION OF A LAYER OF MANGANESE DIOXIDE ON THE SURFACE OF THE MACROPOROUS SORBENT FOR RADIUM SORPTION

*Berseneva M.A.<sup>1</sup>, Semenishchev, V.S.<sup>1</sup>, Kirillov E.V.<sup>1</sup>, Gordeev E.V.<sup>1</sup>*

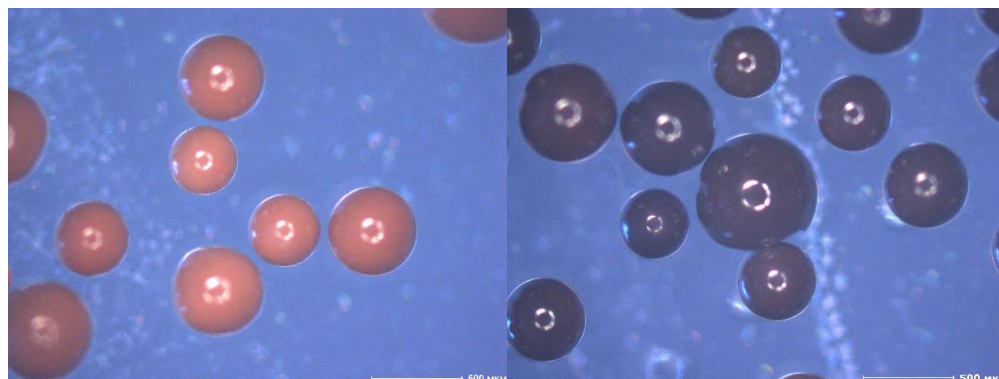
<sup>1</sup>Ural Federal University, Saint Petersburg, Russia

Student

[maryanaberseneva@mail.ru](mailto:maryanaberseneva@mail.ru)

Radium is a radioactive alkaline earth element with the chemical properties very similar to calcium, strontium and barium. Because of the radiotoxicity of radium, it is necessary to determine its activity in drinking water. However, due to the low activity of radium in aqueous media, the techniques of pre-concentration and selective separation are used in analytical methods. There are works describing the sorption of radium on a thin-layer MnO<sub>2</sub>-CTA sorbent, which is a layer of manganese dioxide deposited on a cellulose triacetate film [1], [2]. The purpose of this work was to deposit a layer of manganese dioxide on the surface of a macroporous sorbent and to study the fundamental possibility of sorption of radium on it.

To apply manganese oxide to the sorbent surface, a sample of resin weighing 2.5 g was placed in a plastic test tube and mixed with a 0.1 M solution of potassium permanganate with a volume of 30 ml for 24 h. pH of the solution is 9. Then the solution was separated from the sorbent on the filter, the sorbent surface was washed with a solution weak hydrochloric acid. Then the resin was kept in a drying cabinet for 24 hours at a temperature of 50 ° C to remove moisture residues. The presence of a layer of manganese dioxide on the surface of the sorbent was established visually and using an optical microscope (Fig.1).



**Figure 1.** Image of the resin from an optical microscope a) before applying a layer of manganese dioxide and b) after applying a layer of manganese dioxide.

MN202 resin is spherical brown beads, after mixing with potassium permanganate solution the resin has acquired a dark purple color. This allowed us to visually assess the presence of manganese on the sorbent surface. Experiments on the sorption of <sup>223</sup>Ra were carried out on the obtained sorbent. Sorption experiments were carried out on a <sup>223</sup>Ra solution obtained from an isotope generator based on <sup>227</sup>Ac. The degree of sorption was 90%.

## References

- [1] Semenishchev V. S., Tomashova L. A. The study of sorption of Ra-223 by a thin-layer manganese dioxide sorbent //AIP Conference Proceedings. – AIP Publishing LLC, 2020. – T. 2313. – №. 1. – C. 050052.
- [2] Semenishchev V. S. et al. Determination of Ra-224 and Ra-226 in drinking waters //AIP conference proceedings. – AIP Publishing LLC, 2017. – T. 1886. – №. 1. – C. 020061.

INVESTIGATION OF PHASE EQUILIBRIA IN A MUTUAL SYSTEM OF POTASSIUM AND BARIUM BROMIDES AND TUNGSTATES

*Berezova E.A., Danilushkina E.G.*

Samara State Technical University

Student

[Berezova11@gmail.com](mailto:Berezova11@gmail.com)

Multicomponent salt systems based on salts are of great practical importance for the creation of multifunctional materials, such as electrolytes for chemical current sources, heat-accumulating and heat-conducting compositions, as well as for the theory of ionic melts. [1-2]

The study of the three-component mutual system was carried out by the DTA method [3]. The initial reagents  $\text{BaBr}_2$ ,  $\text{KBr}$ ,  $\text{K}_2\text{WO}_4$ ,  $\text{BaWO}_4$  were previously prepared. The potassium and barium bromides were melted, and the potassium and barium tungstates were calcined for 40 minutes at a temperature of 700-750 °C. The square of the compositions of the three-component mutual system is shown in Fig. 1. At the  $\text{K}_2$  point, the  $\text{BaBr}_2 + \text{K}_2\text{WO}_4 \rightarrow \text{BaWO}_4 + 2\text{KBr}$  exchange reaction takes place. The presence of a double compound of the dystectic melting type in one of the binary systems and the calculation of the Gibbs energy at the  $\text{K}_2$  conversion point suggests the following variant of splitting the system into simplexes. The secant  $\text{KBr}-\text{BaWO}_4$  and  $\text{D}_1-\text{BaWO}_4$  divide the system into three simplexes:  $\text{KBr} - \text{K}_2\text{WO}_4 - \text{BaBr}_2$ , and  $\text{KBr} - \text{D}_1 - \text{BaWO}_4$  and  $\text{D}_1 - \text{BaWO}_4 - \text{BaBr}_2$ . To confirm the partition, the  $\text{KBr} - \text{BaWO}_4$  quasi-binary system was experimentally studied. The characteristics of the quasi-double eutectic point  $e$  (725 °C, 95 %  $\text{KBr}$ .) are determined.

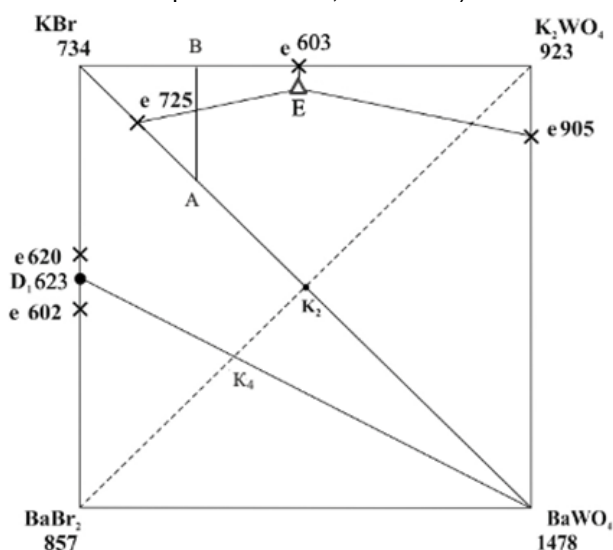


Figure 1. Three-component mutual system K, Ba || Br,  $\text{WO}_4$ .

For the experimental study of the triple mutual system K, Ba || Br,  $\text{WO}_4$  in the stable triangle  $\text{KBr} - \text{K}_2\text{WO}_4 - \text{BaWO}_4$  according to the rules of the projection-thermographic method [4], the polythermal section AB in the field of crystallization of potassium bromide was chosen. The study of the AB section determined the temperature of the triple eutectic point at 586°C and the projection of the point on the section (the ratio of the components  $\text{K}_2\text{WO}_4$  and  $\text{BaWO}_4$  at the triple point). The composition of the triple eutectic point is determined by studying the section originating from the  $\text{KBr}$  vertex and passing through the projection point.

#### References

- [1] I. K. Garkushin, G. E. Yegortsev, M. A. Istomova, *Electrochemical Power Engineering*, **2009**, 9, 2, 95-109.
- [2] I. K. Garkushin, E. M. Dvoryanova, T. V. Gubanova, E. I. Frolov, M. A. Istomova, A. I. Garkushin. *Journal of neorgan. Chemistry*, **2015**, 60, 3, 374-391.
- [3] Yegunov V. P. Introduction to thermal analysis. Samara: SamVen, **1996**. 270 p.
- [4] Kosmyrin A. S., Trunin A. S. Projection-thermographic method for studying heterogeneous equilibria in condensed multicomponent systems. Tr. Samar. scientific. schools of physics and chemistry. analysis of multicomponent systems. Vol. 9. Samara, Samara State Technical University. univ., **2006**. 183 p.

## CYCLOMETALATED IRIDIUM(III) COMPLEXES WITH PERIMIDINE-BASED LIGANDS

Kalle P.<sup>1</sup>, Kiseleva M.A.<sup>1,2</sup>, Tatarin S.V.<sup>1,2</sup>, Bezzubov S.I.<sup>1</sup>

<sup>1</sup>Kurnakov Institute of General and Inorganic Chemistry, Moscow, Russia

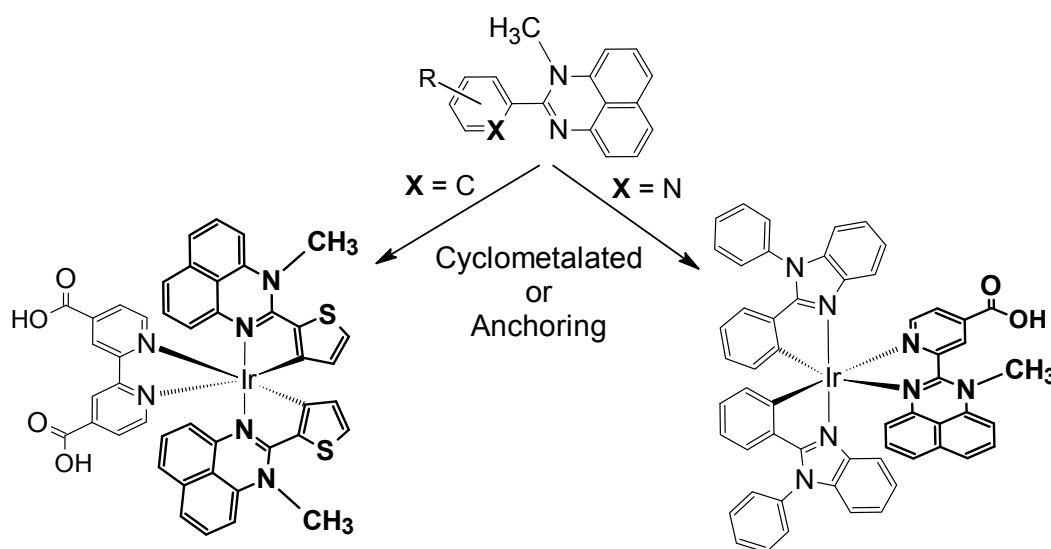
<sup>2</sup>Moscow State University, Moscow, Russia

PhD Student

[bezzubov@igic.ras.ru](mailto:bezzubov@igic.ras.ru)

The unique physicochemical properties of cyclometalated iridium(III) complexes – in particular, their high thermodynamic and kinetic stability and intense phosphorescence - make it possible to consider these compounds as potential photosensitizers when creating effective photovoltaic devices. To use iridium dyes in dye-sensitized solar cells, it is necessary to broaden the absorption spectrum of the complexes and to increase the extinction coefficients. We assume that the use of perimidines (one of the most  $\pi$ -donor heterocycles) as ligands in cyclometalated iridium(III) complexes will significantly expand the absorption spectrum and enhance the extinction coefficients of the dyes.

Herein, we synthesized several cyclometalated iridium(III) complexes with 2-arylperimidines acting as either cyclometalated or ancillary ligands (scheme 1).



**Scheme 1.** Cyclometalated iridium(III) complexes in this study.

The complexes exhibited high molar absorptivity in the visible spectral range and were successfully tested in solar cells.

Acknowledgements. This work was supported by the Presidential Grant Program (project MK-1200.2020.3).

# SYNTHESIS AND PROPERTIES OF PROPIONITRILIUM DERIVATIVES OF COBALT AND IRON BIS(DICARBOLLIDES)

*Bogdanova E.V.*<sup>1</sup>, *Stogniy M.Yu.*<sup>1,2</sup>, *Sivaev I.B.*<sup>1</sup>, *Bregadze V.I.*<sup>1</sup>

<sup>1</sup> A.N. Nesmeyanov Institute of Organoelement Compounds, Russian Academy of Sciences, Moscow, Russia.

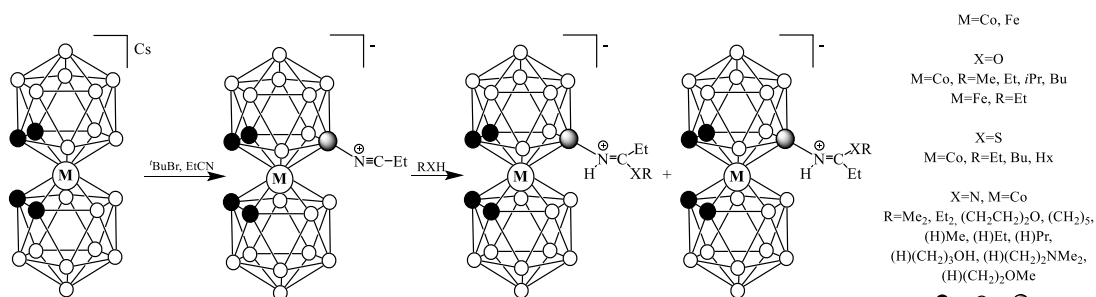
<sup>2</sup> M.V. Lomonosov Institute of Fine Chemical Technology, MIREA - Russian Technological University, Moscow, Russia

PhD Student

[bogdanovakatte@mail.ru](mailto:bogdanovakatte@mail.ru)

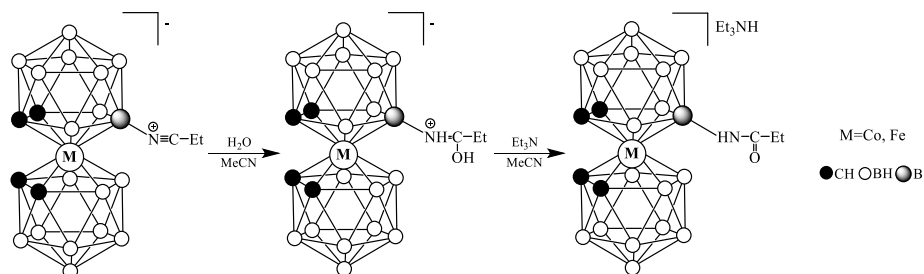
The metallocarboranes, and first of all, cobalt and iron bis(dicarbollides) have shown the promise of their use in various fields, from medicinal chemistry to the creation of new materials. In this regard the development of methods for their functionalization is very important [1].

In this work the propionitrilium derivatives of cobalt and iron bis(dicarbollides) were prepared by the reaction of cesium salts of the parent bis(dicarbollide) anions with propionitrile in the presence of *tert*-butyl bromide. The nucleophilic addition reactions of alcohols, thiols and amines to the  $-N^+=C$  triple bond of the prepared nitrilium derivatives were studied and a series of imidates, thioimidates and amidines were synthesized as mixtures of E and Z-isomers.



**Figure 1.** The synthetic route to the nitrilium derivatives of cobalt and iron bis(dicarbollides) and the study of the nucleophilic addition reactions to them

The hydrolysis of propionitrile derivatives of cobalt and iron bis(dicarbollides) led to the charge-compensated iminols, the treatment of which with triethylamine resulted in anionic amides [2].



**Figure 2.** The hydrolysis of the nitrilium derivatives of cobalt and iron bis(dicarbollides)

## References

[1] Grimes R. N. *Carboranes*. London: Academic Press, London, **2016**. P. 711-903.

[2] Bogdanova E. V., Stogniy M. Yu., Chekulaeva L. A., Anisimov A. A., Suponitsky K. Yu., Sivaev I. B., Grin M. A., Mironov A. F., Bregadze V. I. *New J. Chem.* **2020**, 44, 15836 – 15848.

Acknowledgments. This work was supported by Russian Foundation for Basic Research (project № 19-03-00255 A)

# KINETICS OF THE PROCESS OF SORPTION OF HYDROGEN SULFIDE ON FERROMANGANESE MATERIAL

*Bolotov V.A., Cheremisina O.V., Ponomareva M.A., Osipov A.S.*

Saint Petersburg Mining University, Saint Petersburg, Russia  
PhD student  
[vab-94@mail.ru](mailto:vab-94@mail.ru)

Today, metallurgical gas emissions are a serious problem. For cleaning from harmful gaseous impurities, the most effective method of gas sorption on solid materials is used. Many studies by domestic scientists have shown that one of the most promising solid sorbents are manganese materials with high selectivity towards H<sub>2</sub>S.

The aim of this work is to determine the kinetic regularities of the sorption of hydrogen sulfide by solid sorbents exhibiting obvious oxidizing properties, to determine the mechanism and to identify a number of specific characteristics of the sorption heterogeneous process.

In this work, we studied the kinetics of sorption of ferromanganese ore with a specific surface area of 110 m<sup>2</sup>/g. The ore includes manganese, silicon, aluminum, and iron. According to the results of X-ray phase analysis, it was determined that the composition of the ore includes such phases as a mixture of oxides of iron (II) and (III), takanelite and quartz.

As a result of the experiment, kinetic dependences of changes in the concentration of hydrogen sulfide in samples at various temperatures (255, 280, 298 K) over time were obtained. When processing the obtained kinetic curves, a linear dependence of the logarithm of the concentration of hydrogen sulfide (lnC) on the sorption time was obtained, the value of the sorption activation energy  $E_a = 3.9$  kJ/mol was calculated, according to which the limiting stage, which is a chemical reaction, was determined.

In order to reveal the catalytic action of iron (III) oxide, we carried out the sorption of hydrogen sulfide on model samples of manganese (IV) oxide and on iron (III) oxide. An experiment on iron oxide showed that it does not exhibit sorption properties with respect to hydrogen sulfide. The kinetic dependences of sorption on a mixture of oxides were used to calculate the activation energy  $E_a = 18.6$  kJ/mol.

To confirm the catalytic action of iron oxide, the elemental composition of the ore was determined before and after contact with hydrogen sulfide. The results indicate the appearance of sulfur in the composition of the ore, which indicates the occurrence of another stage of the sorption process - chemisorption, namely, the redox reaction, which is catalyzed by iron (III) oxide.

The results of X-ray phase analysis demonstrate the appearance of a new hydrated crystalline phase Mn<sub>2</sub>O<sub>3</sub> · 2H<sub>2</sub>O, which is absent in the initial samples. Based on the analysis of the products of sorption absorption of hydrogen sulfide, the process is expressed by a chemical redox reaction:  $2\text{MnO}_2 + \text{H}_2\text{S} = \text{S} + \text{Mn}_2\text{O}_3 + \text{H}_2\text{O}$ .

In order to determine the contribution of iron (III) oxide as a catalyst to the sorption process, the thermal effect of hydrogen sulfide sorption was determined, which was -69.44 KJ/mol, and the Bronsted-Polyani ratio was used to calculate the degrees of catalyst coverage with the initial hydrogen sulfide and chemisorption products through experimentally obtained expressions and were  $\theta_1 = 0.23$  and  $\theta_2 = 0.07$ , respectively.

As a result, the established features of the catalytic process of H<sub>2</sub>S sorption by ferromanganese materials contribute to the creation of a promising catalyst for the implementation of catalytic reactions on an industrial scale.

## References

- [1] Bolotov, V.A.; Cheremisina, O.V.; Ponomareva, M.A.; Alferova, D.A.. *Key Eng. Mater.* **2020**, *836*, 13–18.
- [2] Kadirova, Z.C.; Katsumata, K.; Isobe, T.; Matsushita, N.; Nakajima, A.; Okada, K. *Appl. Surf. Sci.* **2013**, *284*, 72–79.
- [3] Kovshov, S.V.; Skamyin, A.N. *Environ. Earth Sci.* **2017**, *76*, 660.
- [4] Lau, L.C.; MohamadNor, N.; Lee, K.T.; Mohamed, A.R. *Int. J. Petrochemical Sci. Eng.* **2016**, *1*, 36–44.

Acknowledgements. The study was carried out at the expense of a subsidy for the fulfillment of the state task in the field of scientific activity for 2021 No. FSRW-2020-0014.



SYNTHESIS AND CRYSTAL STRUCTURE OF NEW LUTETIUM FLUOROTRIFLUOROACETATE  
[Lu<sub>2</sub>(μ<sub>2</sub>-F)(η<sup>2</sup>-CF<sub>3</sub>COO)<sub>4</sub>(H<sub>2</sub>O)<sub>3</sub>](CF<sub>3</sub>COO)

*Boltkov E.D.*<sup>1</sup>, *Belousov Yu.A.*<sup>1</sup>, *Glazunova T.Yu.*<sup>1</sup>, *Lermontova E.Kh.*<sup>2</sup>

<sup>1</sup>Moscow State University, Moscow, Russia

<sup>2</sup>Kurnakov Institute of General and Inorganic Chemistry

Student

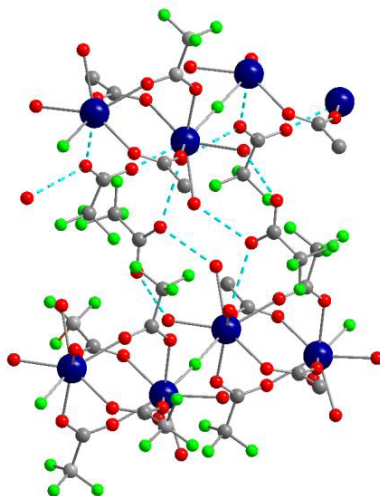
[mr.boltkov@icloud.com](mailto:mr.boltkov@icloud.com)

In the work published last year, we reported the existence of isotopic fluorotrifluoroacetate complexes of lanthanides with the general formula Na<sub>2</sub>[Ln<sub>6</sub>(μ<sub>3</sub>-F)<sub>8</sub>(η<sup>2</sup>-CF<sub>3</sub>COO)<sub>12</sub>], Ln = Nd, Tb and their crystal structure [1]. These compounds were obtained in trifluoroacetic acid from Ln<sub>2</sub>(CO<sub>3</sub>)<sub>3</sub> in the presence of NaF.

In this work the possibility of synthesizing individual fluorotrifluoroacetate complexes of lanthanides has been shown for the first time and their crystal structure has been studied. In contrast to the island structure of heteronuclear ionic complexes [1] chain structure [Lu<sub>2</sub>(μ<sub>2</sub>-F)(η<sup>2</sup>-CF<sub>3</sub>COO)<sub>4</sub>(H<sub>2</sub>O)<sub>3</sub>](CF<sub>3</sub>COO) (I) is formed.

Lu<sub>2</sub>(CO<sub>3</sub>)<sub>3</sub> was dissolved by heating in concentrated 90% trifluoroacetic acid. To the resulting solution was added a 0.75 M aqueous solution of hydrofluoric acid with vigorous stirring. The resulting solution was left in a desiccator over phosphoric anhydride. With complete removal of the solvent, it is possible to isolate compound I in the form of crystals suitable for X-ray diffraction analysis.

According to X-ray diffraction data, the compound crystallizes in the triclinic system, space group P -1, with unit cell parameters a = 7.9158 (19) Å, b = 21.271 (4) Å, c = 26.307 (7) Å, α = 84.803 (11) °, β = 87.675 (12) °, γ = 85.232 (10) °, V = 4393.6 (18) Å<sup>3</sup>, Z = 2. In contrast to the island structure of heteronuclear ionic complexes, an individual complex forms a chain structure. Each chain is formed by Lu<sub>2</sub>(CF<sub>3</sub>COO)<sub>4</sub> dimers. Metal atoms in dimers are linked by four bidentate trifluoroacetate groups. The dimers are linked to each other by bidentate fluorine ions. The coordination environment of each lutetium atom is complemented to a quadrangular antiprism by three oxygen atoms of water molecules. The coordination number of the metal is 8. The structure contains uncoordinated anions and acid molecules. Each solvate particle participates in the formation of three hydrogen bonds with two oxygen atoms of the water molecules included in the coordination environment of lutetium atom of one chain and with the oxygen atom of the water molecule coordinated by the lutetium atom of the neighboring chain (Figure 1).



**Figure 1.** Crystal structure of [Lu<sub>2</sub>(μ<sub>2</sub>-F)(η<sup>2</sup>-CF<sub>3</sub>COO)<sub>4</sub>(H<sub>2</sub>O)<sub>3</sub>](CF<sub>3</sub>COO).

#### References

[1] Boltkov E.D. Materials of the International Youth Scientific Forum "LOMONOSOV-2020". **2020**, 170-171

Acknowledgements. This work was supported by Russian Foundation for Basic Research (project No 19-03-01059 A).

# INVESTIGATION OF THE EFFECT OF HALOGEN SUBSTITUTION ON THE STRUCTURAL FEATURES AND SENSOR PROPERTIES OF METAL PHTHALOCYANINES

*Bonegardt D.V.<sup>1</sup>, Klyamer D.D.<sup>1</sup>, Sukhikh A.S.<sup>1</sup>, Basova T.V.<sup>1</sup>*

<sup>1</sup>Nikolaev Institute of Inorganic Chemistry, Novosibirsk, Russia

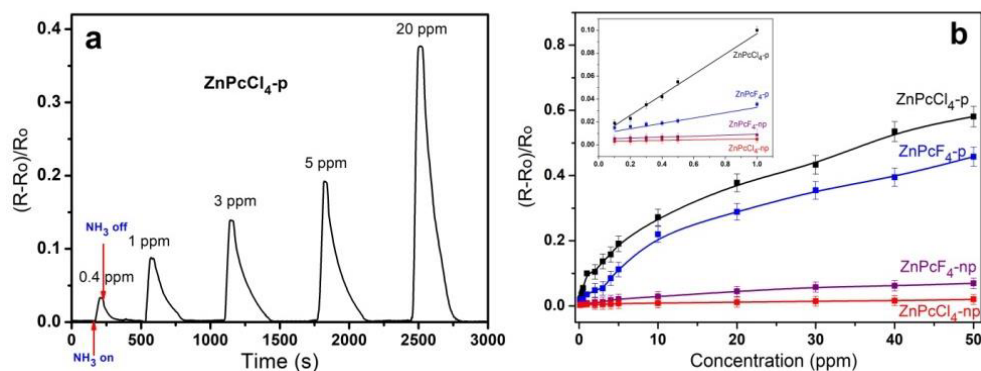
PhD Student

[bonegardt@niic.nsc.ru](mailto:bonegardt@niic.nsc.ru)

Metal phthalocyanines (MPcs) are of significant interest as active layers of chemical sensors due to their thermal and chemical stability, ability to form thin films and change their conductivity depending on the composition of the gaseous phase [1]. Thin films of phthalocyanines have reversible sensor response to various gaseous analytes at room temperature with a reasonably low response time. The ability of phthalocyanine films to change their conductivity in different gas media can be used for the production of low cost portable chemiresistive sensors.

Introduction of various substituents into the phthalocyanine macrocycle can considerably change the films' structure and morphology and, therefore, affect their electrical, optical and sensing properties. Introduction of halogen substituents causes a decrease in the electronic density of the aromatic macrocycle and an increase in the oxidation potential of the MPc molecule. This leads to a better sensor response to reducing gases, such as hydrogen or ammonia. It was shown in previous works that the sensor response of films of fluorosubstituted phthalocyanines was higher compared to their unsubstituted analogues [2]. However, the works on investigation of the effect of other halogen substituents in MPc molecules on the sensor properties were not found in the literature.

In this work, the sensor response of thin films of  $ZnPcX_4$  ( $X=F, Cl$  in peripheral and nonperipheral positions) films toward gaseous  $NH_3$  (0.1-50 ppm) was investigated by chemiresistive method in the presence of various interfering gases (Fig.1). The structure of tetrahalogen-substituted zinc phthalocyanines and their thin films were examined by spectroscopic (IR, Raman, UV-VIS) and X-ray diffraction methods. The assignment of the most intense bands both in IR and Raman spectra was performed on the basis of DFT calculations.



**Figure 1.** (a) Real-time sensor response of a  $ZnPcCl_4$ -p film to ammonia, measured at RH 10 % and 25 °C. (b) Dependence of the sensor response of  $ZnPcF_4$ -np,  $ZnPcF_4$ -p,  $ZnPcCl_4$ -np, and  $ZnPcCl_4$ -p sensing layers on ammonia concentration.

## References

- [1] Wannebroucq, A., Gruntz, G., Suisse, J. M., Nicolas, Y., Meunier-Prest, R., Mateos, M., Toupance T., Bouvet M. *Sensors and Actuators B: Chemical* **2018**, 255, 1694
- [2] Klyamer D.D., Sukhikh A.S., Krasnov P.O., Gromilov S.A., Morozova N.B., Basova T.V. *Applied Surface Science* **2016**, 372, 79

Acknowledgements. This work was supported by the Russian Science Foundation (project No 20-73-00080).

# SYNTHESIS, CRYSTAL STRUCTURE, AND FUNCTIONAL PROPERTIES OF CADMIUM(II)-BASED FLEXIBLE MOFs

*Burlak P.V.<sup>1</sup>, Kovalenko K.A.<sup>1</sup>*

<sup>1</sup>Nikolaev Institute of Inorganic Chemistry, Novosibirsk, Russia  
PhD Student  
[burlakpv@gmail.com](mailto:burlakpv@gmail.com)

The design and syntheses of coordination polymers have attracted great attention of scientists all over the world. The number of polymers are growing very fast, due to its potential wide application in photochemistry, heterogeneous catalysis and adsorption. This is made possible by the incredible variety of the structures. However, the prediction and obtaining of the desired MOFs is still a fundamental scientific problem, since a large number of factors, such as the coordination preferences of metal ions, the role of multifunctional linkers, solvents, and temperatures in the synthesis, affect the nature of coordination and formation of structures in different ways. There are different strategies in synthesis of MOFs, for example using two types of ligands — carboxylate and N-donor. As a special case — using imidazole-like ligands with modified (-NO<sub>2</sub>, -Br, -NH<sub>2</sub>...) terephthalic acid as a secondary ligand are shown good performance for gas adsorption, catalysis and luminescence. One of these ligands is 1,3-bis(2-methyl-imidazolyl)propane (bmip), due to its flexible alkyl group, it becomes possible to obtain unusual, complex structures with the necessary textural and functional characteristics [1, 2].

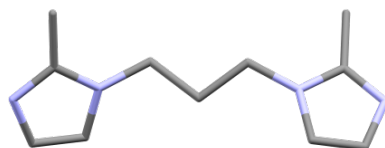
In this work were obtained and characterized two pairs of isostructural metal-organic coordination polymers based on Cd, bmip and nitro-/bromo-terephthalate anions (bdc-X, X=-NO<sub>2</sub>, -Br) as ligands:



Fresh [Cd(bdc-X)bmip] crystallized with diamond topology and have 2-fold-interpenetrating structure with void volume about 35%. However, the replacement or removal of the solvent leads to dramatic changes in the structure of the framework. Using Et<sub>2</sub>O, EtOH or air we obtained isomeric structure with diamond topology, but 4-fold interpenetrating structure with lower void volume. These flexible structure of compound create interesting behavior in sorption of C<sub>2</sub>-hydrocarbons and luminescence properties. So, usually in the series C<sub>2</sub>H<sub>2</sub>, C<sub>2</sub>H<sub>4</sub>, C<sub>2</sub>H<sub>6</sub>, a regular decrease in sorption capacity is observed due to an increase in the size of hydrocarbons. However, in the case of the obtained compounds, the maximum sorption capacity is observed in the case of C<sub>2</sub>H<sub>4</sub>, which is clearly associated with the structural changing during the adsorption process.

Moreover, the luminescence properties are unusual too. We observed a normative change in the emission maxima depending on λ<sub>ex</sub>. This complex behavior is caused by the complex structure of the resulting framework. Thus, by changing the λ<sub>ex</sub>, we can get different colors emitted, including white.

[Cd<sub>3</sub>(bdc-X)<sub>3</sub>(bmip)<sub>2</sub>] crystallized into rigid layers formed by the building blocks of Cd<sub>3</sub>, interconnected by anions of terephthalic acid derivatives. These layers, in turn, are combined into a three-dimensional structure using the bmip ligand. The bmip ligand in a compressed position can give the possibility of obtaining the effect of opening the gate during the sorption of gases or vapors. We have shown, that using different solvents, we had obtained a different structures with different luminescence and sorption properties.



**Figure 1.** 1,3-bis(2-methyl-imidazolyl)propane (bmip)

## References

- [1] Schneemann A. et al. *Chem. Soc. Rev.* **2014**, 43, 6062–6096.  
[2] Wang J. et al. *J. Mol. Struct.* **2019**, 1182, 79–86.

Acknowledgements. This work was supported by the Russian Science Foundation (project No 19-73-20087) and Russian Foundation for Basic Research (project No 20-33-90207).

SYNTHESIS AND CRYSTAL STRUCTURE OF SODIUM HEXATRIFLUOROACETATOTITANATE (IV)  
 $\text{Na}_2[\text{Ti}(\text{CF}_3\text{COO})_6] \cdot 2\text{CF}_3\text{COOH}$

*Buzoverov M.E.*<sup>1</sup>, *Glazunova T. Yu.*<sup>1</sup>, *Lermontova E. Kh.*<sup>2</sup>

<sup>1</sup>Moscow State University, Moscow, Russia

<sup>2</sup>Institute of General and Inorganic Chemistry, Moscow, Russia  
Student

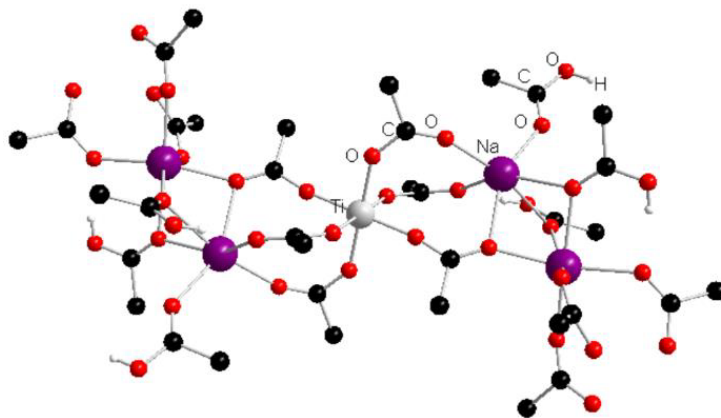
[agentneopentan@gmail.com](mailto:agentneopentan@gmail.com)

Titanium compounds are biocompatible and therefore could be used in medicine [1]. The study of titanium compounds with organic ligands and their role in the human body is an important practical task. For example, it was found that titanocene dichloride has an anti-cancer effect [2], and the biological role of titanium (III) and (IV) citrate complexes was studied [1, 3].

The synthesis and crystal structure of the sodium hexatrifluoroacetotitanate (IV), the first mononuclear complex of titanium (IV) and monobasic carboxylic acid described using the X-ray crystallography method, is outlined in this paper. The composition of its thermal degradation products is also discussed.

Colorless crystals of the product, which is extremely unstable in air, were obtained as a result of a new synthesis. Titanium (IV) tetrachloride was dissolved in a mixture of trifluoroacetic acid – trifluoroacetic anhydride in an argon atmosphere and sodium trifluoroacetate was added to the resulting solution. Then the resulting solution was kept in the desiccator at a reduced pressure over the phosphoric anhydride.

A fragment of the crystal structure of the sodium hexatrifluoroacetotitanate (IV) is shown in Figure 1. The compound has a structure consisting of corrugated layers connected to a three-dimensional framework by means of hydrogen bonds. Inside each layer, a pair of sodium atoms and a titanium atom bound together by trifluoroacetate ions alternate in a staggered pattern. Two crystallographically independent titanium atoms have a distorted octahedral environment, which consists of six oxygen atoms of the bidentate groups ( $\text{CF}_3\text{COO}$ ). The coordination environment of the two sodium atoms is also a distorted octahedron, but it is composed of oxygen atoms of both trifluoroacetate ions and neutral trifluoroacetic acid molecules. The third sodium atom has an irregular polyhedron with eight vertices.



**Figure 1.** Fragment of the crystal structure of  $\text{Na}_2[\text{Ti}(\text{CF}_3\text{COO})_6] \cdot 2\text{CF}_3\text{COOH}$  (fluorine atoms omitted).

In addition, it was found that when decomposed in vacuum, this compound makes it possible to obtain complex fluorides of the  $\text{TiF}_4 - \text{NaF}$  system.

#### References

- [1] Kefalas, E.T., Panagiotidis P. et al. *Inorg. Chem.* **2005**, *44*, 2596–2605.
- [2] Köpf-Maier, P. *Eur. J. Clin. Pharmacol.* **1994**, *47*, 1–16.
- [3] Schneider, K., Müller, A., Krahn, E. et al. *FEBS J.* **1995**, *230*, 666–675.

Acknowledgements. This work was supported by Russian Foundation for Basic Research (project No 19-03-01059 A).

# OUT-PROTONATION OF DMAN PROTON SPONGE BY PHOSPHINIC ACID

*Chakalov E.R.*<sup>1</sup>, *Mulloyarova V.V.*<sup>1</sup>, *Antonov A.S.*<sup>1</sup> and *Tolstoy P.M.*<sup>1</sup>

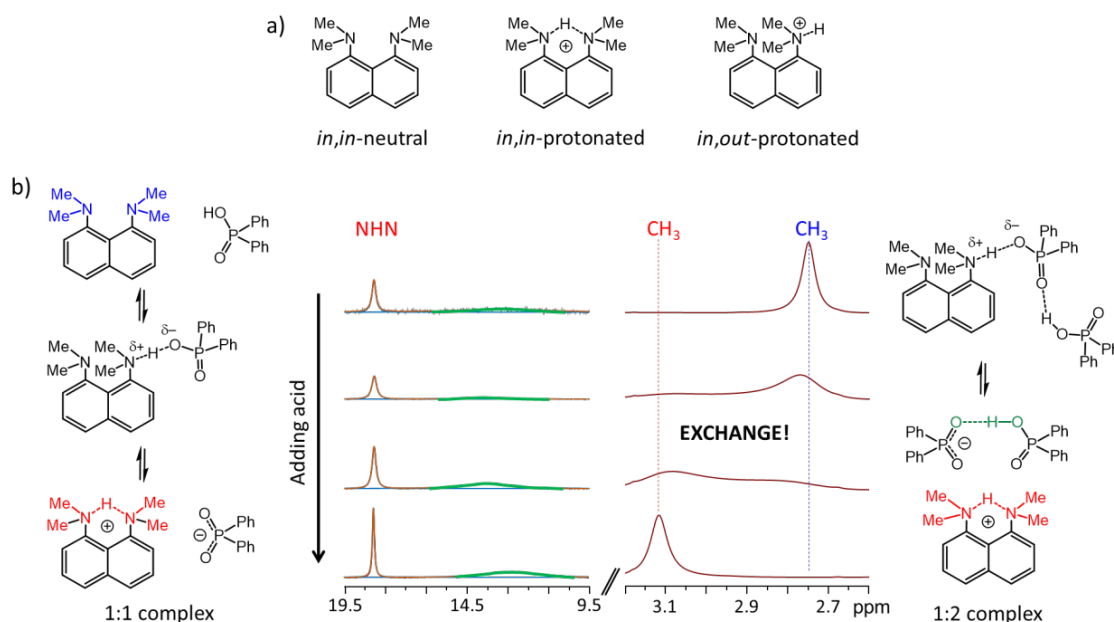
<sup>1</sup>Saint Petersburg State University, Saint Petersburg, Russia

Student

[st086266@student.spbu.ru](mailto:st086266@student.spbu.ru)

The vast majority of proton sponges including the parent 1,8-bis(dimethylamino)naphthalene (DMAN) usually exist in the so-called *in,in*-conformation (Fig. 1a, left), in which the methyl groups are turned outside and axes of the nitrogen free electron pairs point inside the inter-nitrogen space [1]. An electrostatic repulsion between the electron pairs and steric repulsion of the four methyl groups strongly destabilize the neutral base. The protonation by an acid AH results in the formation of a strong (NHN)<sup>+</sup> hydrogen bond (chelated cation H<sup>+</sup>; Fig. 1a, middle) which removes the electrostatic and steric strains and thus provides a considerable decrease in Gibbs free energy, causing an exceedingly high DMAN proton sponge basicity (pK<sub>a</sub> = 12.1 [2]). In aprotic media protonated proton sponges usually exist as an ion pair with the acid's residue A<sup>-</sup>. The somewhat hypothetical *in,out*-protonated form of unsubstituted DMAN (Fig. 1a, right) is an elusive short-lived intermediate state on its protonation pathway [3,4].

POOH-containing acids (R<sub>2</sub>POOH, (RO)<sub>2</sub>POOH) are strong proton donors (f.e. pK<sub>a</sub>(Ph<sub>2</sub>POOH) = 2.32) which are known to form strong H-bonds in self-associates [5]. We have studied 1:1 and 1:2 complexes of DMAN with several POOH acids in polar aprotic medium by <sup>1</sup>H NMR (Fig. 1b; solvent: DMSO, 298 K). Despite the huge difference in the basicity of the acid and the base we found evidence for the facilitated exchange between neutral and protonated base, indicating the unusual stabilization of the *in,out*-conformation of DMAN-H<sup>+</sup> presumably due to the formation of a short strong NHO hydrogen bond with the Ph<sub>2</sub>POO<sup>-</sup> anion. This hypothesis was further supported by the results of low-temperature <sup>1</sup>H and <sup>31</sup>P{<sup>1</sup>H} NMR measurements (solvent: liquefied gas mixture CDF<sub>3</sub>/CDCF<sub>2</sub>, 100 K) and quantum-chemical calculations (DFT) including the potential energy profile for the protonation pathway in 1:1 and 1:2 complexes.



**Figure 1.** <sup>1</sup>H NMR spectrum of an equimolar mixture of DMAN and Ph<sub>2</sub>POOH in DMSO at 298 K.

## References

- [1] P. R. Mallinson, K. Wozniak, C. C. Wilson, K. L. McCormack, D. C. Yufit, *J. Am. Chem. Soc.* **1999**, *121*, 4640–4646.
- [2] F. Hibbert, *J. Chem. Soc., Perkin Trans. 2* **1974**, 1862–1866.
- [3] A. Szemik-Hojniak, J. M. Zwier, W. J. Buma, R. Bursi, J. H. van der Waals, *J. Am. Chem. Soc.* **1998**, *120*, 4840–4844.
- [4] V. A. Ozeryanskii, A. F. Pozharskii, A. S. Antonov, A. Filarowski, *Org. Biomol. Chem.* **2014**, *12*, 2360–2369.
- [5] R. E. Asfin, G. S. Denisov, K. G. Tokhadze, *J. Mol. Struct.* **2002**, *608*, 161–168.

Acknowledgements. This work was supported by the Russian Science Foundation (project № 18-13-00050).

## FLUX GROWN TITANIUM SUBSTITUTED M-TYPE BARIUM HEXAFERRITES

*Cherkasova N.A.<sup>1</sup>, Zhivulin V.E.<sup>1</sup>, Vinnik D.A.<sup>1</sup>*

<sup>1</sup>South Ural State University (National Research University), 454080, Lenin ave. 76, Chelyabinsk, Russia  
Student

[Cherkasova.N.A@yandex.ru](mailto:Cherkasova.N.A@yandex.ru)

This work is devoted to the development of a technology for growing bulk single crystals based on barium hexaferrite ( $\text{BaFe}_{12}\text{O}_{19}$ ) in which iron atoms are partially substituted by titanium atoms.

Single crystals were grown using the spontaneous crystallization from sodium based flux. The choice of sodium oxide as a solvent was due to the fact that it is not incorporated into the crystal structure of barium hexaferrite.

The initial components for the charge preparation were iron oxide  $\text{Fe}_2\text{O}_3$ , titanium  $\text{TiO}_2$  and barium carbonates  $\text{BaCO}_3$ , sodium  $\text{Na}_2\text{CO}_3$ .

To prepare the charge, the initial components were taken in stoichiometric ratios according to the formula  $\text{BaFe}_{10}\text{Ti}_2\text{O}_{19}$  with the addition of 26.6 mol. % sodium carbonate and mixed using an agate mortar. The resulting mixture was placed in a platinum crucible and heated to a temperature of  $1300^\circ\text{C}$ . The crucible volume was 100 ml. The total weight of the charge was 50 g. After melting, the resulting solution was kept at the maximum temperature for 24 hours. Isothermal holding is necessary for good solution homogenization. The furnace was cooled at a rate of  $4.5^\circ\text{C}/\text{h}$  to a temperature of  $1000^\circ\text{C}$  below which the cooling rate was not controlled.

The crystals separation from the solvent was carried out by boiling in an aqueous solution of nitric acid.

The elemental composition of the grown crystals was determined using an Oxford INCA X-max 80 X-ray fluorescence spectrometer installed on a Jeol JSM 7001F electron microscope. The obtained crystals were certified using a Rigaku X-ray diffractometer, model Ultima IV, by the powder method. For this, a small piece was broken off from a bulk single crystal and ground in an agate mortar.

Figure 1 shows photographs of bulk barium hexaferrite single crystals with the brutto formula  $\text{BaFe}_{11.1}\text{Ti}_{0.9}\text{O}_{19}$ .

X-ray diffraction showed that all the crystals obtained have a single hexagonal ferrite phase with a magnetoplumbite structure. According to the X-ray fluorescence analysis data, the brutto formula was calculated.

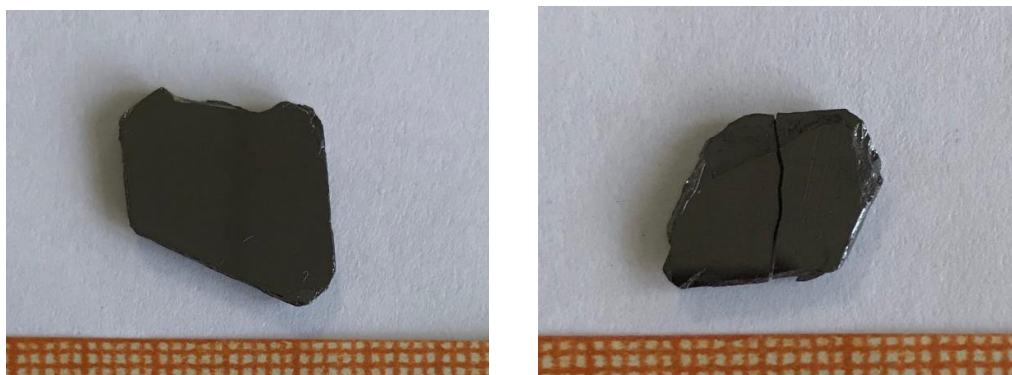


Figure 1. Single crystals of barium ferrite composition  $\text{BaFe}_{11.1}\text{Ti}_{0.9}\text{O}_{19}$ .

As a result of the work, the growth parameters for ferrite  $\text{BaFe}_{11.1}\text{Ti}_{0.9}\text{O}_{19}$  bulk single crystals using spontaneous crystallization from a sodium based flux were developed. The obtained single crystals sizes vary in the range from 2 to 10 mm. The maximum substitution degree of iron with titanium that was achieved in the experiment using current charge composition was  $x(\text{Ti}) = 0.9$ .

Acknowledgements. This work was supported by the reported study was funded by RFBR (project number 20-38-70057).

A NEW APPROACH TO THE STABILIZATION OF Pd/NHC COMPLEXES  
TOWARD DECOMPOSITION IN ALKALINE MEDIA

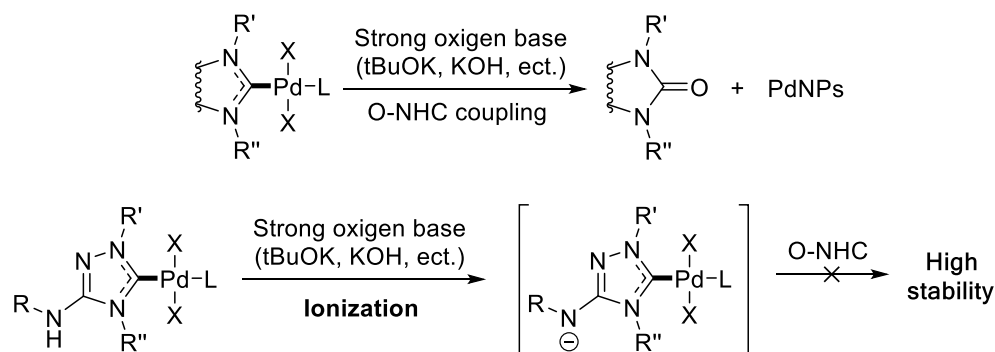
*Chernenko A.Yu.<sup>1</sup>, Astakhov A.V.<sup>1</sup>, Chernyshev V.M.<sup>1</sup>*

<sup>1</sup>Platov South-Russian State Polytechnic University (NPI), Novocherkassk, Russia  
Young scientist  
[chernenko.andrew@mail.ru](mailto:chernenko.andrew@mail.ru)

Homogeneous Pd catalysts with N-heterocyclic carbene ligands have received ubiquitous application as a very powerful tool for promoting numerous organic reactions owing to the high variability of their steric and electronic parameters combined with well-defined binding with Pd species, as well as the great diversity of possible frameworks.

Palladium-catalyzed reactions are often carried out in the presence of strong oxygen-containing bases, including alkali metal hydroxides and alcoholates, which can decompose Pd/NHC complexes by O-NHC coupling to form azolones and palladium black. This process can lead to deactivation of catalytic systems, which is a very important problem for homogeneous catalysis of Pd/NHC complexes in strongly alkaline media [1].

To solve the problem of deactivation of Pd/NHC complexes by O-NHC coupling, we proposed a new approach to stabilize the metal-ligand bond, based on the use of 3-RNH-substituted (R = acyl, aryl, alkyl) 1,2,4-triazole-5-ylidene, which have NH-acidity in an alkaline medium. Deprotonation of the 3-RNH group of the NHC ligand with a strong base leads to the formation of anionic Pd/NHC complexes, which have increased resistance to O-NHC coupling, compared to complexes with non-ionizable NHC ligands [2]. The negative charge of the ionized group conjugated with an aromatic NHC core suppresses undesirable O-NHC coupling reactions.



**Prevents O-NHC coupling up to a few days**

**Figure 1.** Strong base-induced decomposition of common Pd/NHC complexes via O-NHC coupling (top) and deprotonation of new RNH-substituted complexes provided high stability in alkaline media.

New Pd/NHC catalysts have been developed using the proposed approach to stabilization of Pd/NHC complexes in the presence of strong oxygen-containing bases. In the model Suzuki-Miyaura reaction in the presence of KOH, the obtained complexes showed high activity and, in the catalyst recycling mode, provided higher (1.5-2 times) TON values than similar complexes without the RNH group.

#### References

- [1] Chernyshev V. M., Khazipov O. V., Shevchenko M. A., Chernenko A. Yu., Astakhov A. V., Eremin D. B., Pasyukov D. V., Kashin A. S. and Ananikov V. P. *Chem. Sci.*, **2018**, 9, 5564-5577.  
[2] Chernenko A.Yu., Astakhov A.V., Kutyrev V.V., Gordeev E.G., Burykina J.V., Minyaev M.E., Khrustalev V.N., Chernyshev V. M., Ananikov V. P. *Inorg. Chem. Front.*, **2021**, 8, 3382-3401

Acknowledgements. This work was supported by the Russian Science Foundation (project No 19-73-10100).

PYRIDYLETHYL-SUBSTITUTED 1,5-DIAZA-3,7-DIPHOSPHAOCTANES FOR THE SYNTHESIS OF LUMINESCENT COMPLEXES WITH D<sup>10</sup>-METALS

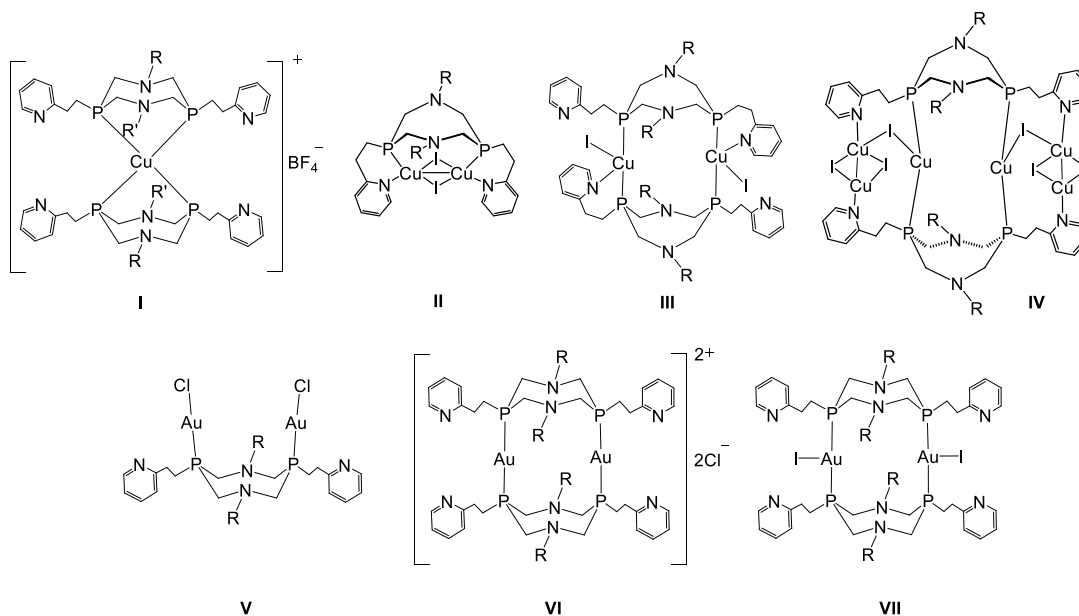
*Dayanova I.R.<sup>1</sup>, Gerasimova T.P.<sup>1</sup>, Strelnik I.D.<sup>1</sup>, Musina E.I.<sup>1</sup>, Karasik A.A.<sup>1</sup>*

Arbuzov Institute of Organic and Physical Chemistry, FRC Kazan Scientific Center of RAS, Kazan, Russia

PhD Student

[dayanova\\_ira@mail.ru](mailto:dayanova_ira@mail.ru)

1,5-Diaza-3,7-diphosphacyclooctanes are synthetic available bidentate phosphine ligands. Easy variation of the substituents on heteroatoms allows to tune the steric and electronic properties of the cyclic ligands. In the current research a wide row of 1,5,3,7-diazadiphosphacyclooctanes containing pyridyl moieties linked to the phosphorus atom via flexible ethylene spacer have been obtained. It was found that diazadiphosphacyclooctanes can form mono- and dinuclear copper(I) complexes. The structure of copper (I) complexes **I-IV** depends on substituents on N-atoms, stoichiometric ratio of the reaction and counter ion nature [1]. The reaction of 1,5-diaza-3,7-diphosphacyclooctanes with gold (I) halides led to the formation of complexes **V-VII** [2].



**Figure 1.** Complexes of Cu (I) and Au (I) with P-pyridylethyl-substituted 1,5-diaza-3,7-diphosphacyclooctanes.

All complexes exhibit moderate luminescence in the solid state. Mononuclear complexes **I** and binuclear complexes **III** exhibit blue emission with  $\lambda_{\max} \approx 480$  nm. Binuclear complexes **II** exhibit green emission with  $\lambda_{\max} \approx 525$  nm. In the emission spectra of hexanuclear complexes **IV** two emission bands are recorded, the luminescence of these complexes is visualized as white. The luminescence of complexes **IV** is sensitive towards the temperature changes. Binuclear gold (I) complexes **V** exhibit luminescence with maxima in the range 496-573 nm and sensitive towards the molecules of organic solvents. Macrocyclic dinuclear gold(I) complexes **VI-VII** display a greenish emission with the maxima in the emission spectra at ca. 540 nm.

### References

- [1] Strelnik I.D., Dayanova I.R., Kolesnikov I.E., Fayzullin R.R., Litvinov I.A., Samigullina A.I., Gerasimova T.P., Katsyuba S.A., Musina E.I., Karasik A.A. *Inorganic Chemistry*, **2019**, *58*, 1048-1057  
 [2] Dayanova I.R., Shamsieva A.V., Strelnik I.D., Kolesnikov I.E., Fayzullin R.R., Musina E.I., Hey-Hawkins E., Karasik A.A. *Inorganic Chemistry*, **2021**, *60*, 7, 5402–5411

Acknowledgements. This work was supported by the Russian Science Foundation (project No 19-43-04119)



# STRUCTURAL DIVERSITY AND OPTICAL PROPERTIES OF 1,4-DIAZABICYCLOCTANE-N,N'-DIOXIDE-BASED METAL-ORGANIC FRAMEWORKS

*Demakov P.A.*<sup>1</sup>

<sup>1</sup>Nikolaev Institute of Inorganic Chemistry SB RAS, Novosibirsk, Russia

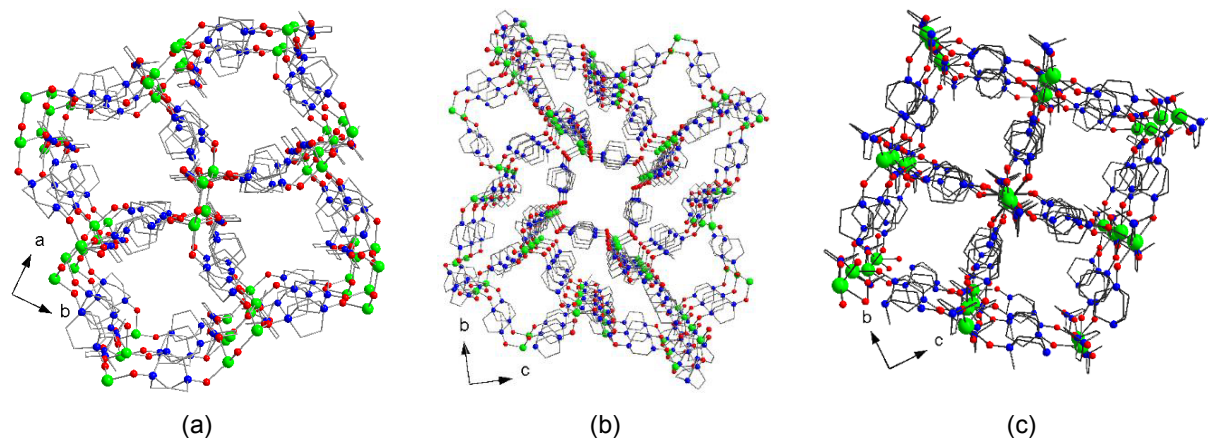
PhD Student

[demakov@niic.nsc.ru](mailto:demakov@niic.nsc.ru)

**Introduction:** Cationic metal-organic frameworks (MOFs) deserve a great interest in such applications as anion selective sorption, detection and post-synthetic functionalization. The targeted synthesis of cationic frameworks can be achieved if the uncharged ligand is used. This class of ligands is mainly represented by N-donors (bipyridyls, imidazole derivatives etc.), which form unstable complexes with oxophilic cations, and therefore are more often used as auxiliary "bridges" in mixed-ligand frameworks. On the opposite, N,N'-dioxides can form more stable coordination compounds with a wide range of metal centers, due to the presence of O donor atoms [1-2]. Such bridges have been poorly studied in the MOF chemistry.

**Results and conclusions:** 1,4-diazabicyclo[2.2.2]octane-N,N'-dioxide (odabco) is quite unique ligand which combines the electroneutrality with aliphatic backbone and corresponding conformational lability [2-4]. Using this ligand, a series of Zn(II) and Ln(III) metal-organic frameworks were synthesized and structurally characterized. Zn(II)-odabco compounds possess great diversity and the structural features of the target network can be predictably designed by tuning the synthetic conditions, especially solvent nature and the anion templation. All the characterized Zn(II) frameworks demonstrate high UV/vis transparency due to the absence of light-absorbing moieties and, therefore, are perfect building blocks for matrices perspective for photochemical applications as well as for materials with tunable photoactivity.

On the contrary, Ln(III) coordination compounds usually demonstrate intensive luminescence which is provided by the cation electronic structure. In this work, new cationic MOFs constructed by Ln(III) and odabco were used as fluorescent sensors on nitrate and nitrite anions by the "turn-off" mechanism. The detection limit for NO<sub>3</sub><sup>-</sup> is near 10<sup>-5</sup> M in DMF solution, what suggests a perfect sensor for the nitrate in the biological and environmental samples.



**Figure 1.** View along the channels in coordination networks: [Zn<sub>2</sub>( $\mu$ -O)(odabco)<sub>3</sub>]<sup>2+</sup> (a, *pcu* topology); [Zn(odabco)<sub>2</sub>]<sup>2+</sup> (b, *bct* topology); [Tb(odabco)<sub>3</sub>]<sup>3+</sup> (c, *pcu* topology). H atoms are not shown.

## References

- [1] Long D.L., Hill R.J., Blake A.J., Champness N.R., Hubberstey P., Wilson C., Schröder M. *Chem. Eur. J.* **2005**, 11, 1384–1391
- [2] López-Cabrelles J., Mínguez Espallargas G., Coronado E. *Polymers* **2016**, 8, 171
- [3] Chen L., Ji Q., Wang X., Pan Q., Cao X., Xu G. *CrystEngComm* **2017**, 19, 5907–5914
- [4] Demakov P.A., Romanov A.S., Samsonenko D.G., Dybtsev D.N., Fedin V.P. *Russ. Chem. Bull.* **2020**, 8, 1511–1519
- [5] Demakov P.A., Yudina Y.A., Samsonenko D.G., Dybtsev D.N. Fedin V.P. *J. Struct. Chem.* **2021**, 62, 403–411

**Acknowledgements.** This work was supported by the Russian Foundation for Basic Research (Project No. 19-43-543016) and by the government of Novosibirsk Region.

SYNTHESIS AND STRUCTURE OF  $[(\text{NH}_2)_2\text{CSSC}(\text{NH}_2)_2]_2[\text{Ru}^{\text{IV}}\text{Br}_6]\text{Br}_2 \cdot 3\text{H}_2\text{O}$

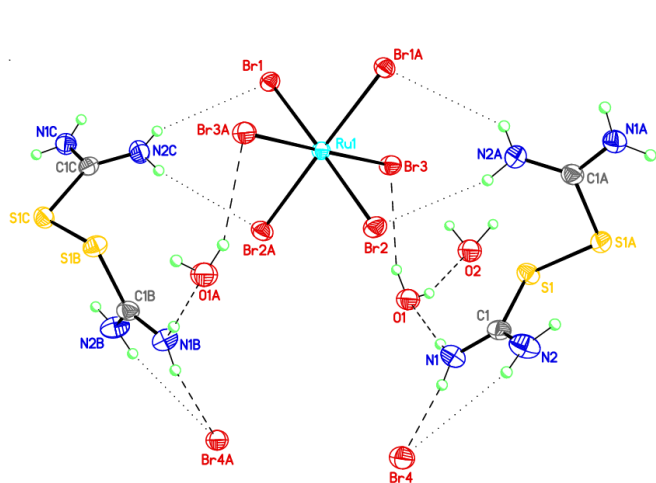
*Dobrokhotova E.V.*<sup>1</sup>, *Rudnitskaia O.V.*<sup>1</sup>, *Kultyshkina E.K.*<sup>1</sup>, *Tereshina T.A.*<sup>1</sup>,  
*Komarovskikh M.R.*<sup>1</sup>, *Pekarskaya M.G.*<sup>1</sup>, *Zelenskaya A.V.*<sup>1</sup>, *Yakushev I.A.*<sup>2</sup>

<sup>1</sup>RUDN, Moscow, RF.  
<sup>2</sup>IGIC RAS, Moscow, RF.  
Young Scientist  
[dobrokhotova-ev@rudn.ru](mailto:dobrokhotova-ev@rudn.ru)

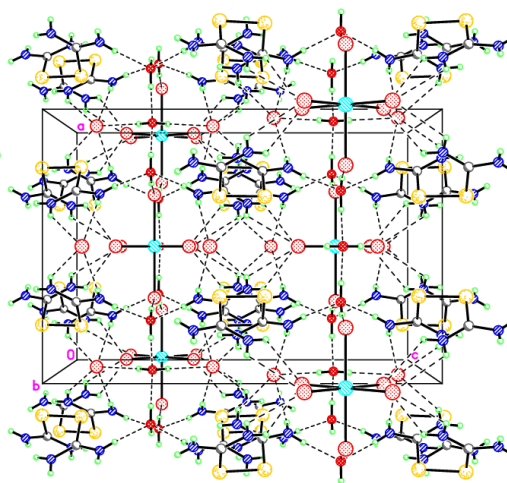
Thiocarbamide (Thio) is a classical ligand, which widely used in the analysis and technology of platinum metals. Thio demonstrate a reducing properties and in an acidic environment can be oxidized to  $[\text{S}_2\text{C}_2(\text{NH}_2)_4]^{2+}$ , which in turn can interact with platinum metal halides.

Dark red crystals were obtained by the reaction of « $\text{RuCl}_3$ » with  $[\text{S}_2\text{C}_2(\text{NH}_2)_4] \text{X}_2$  ( $\text{X}=\text{Cl}, \text{Br}$ ) in conc. HBr, the structure of which was established by X-ray studies. The compound  $[(\text{NH}_2)_2\text{CSSC}(\text{NH}_2)_2]_2[\text{Ru}^{\text{IV}}\text{Br}_6]\text{Br}_2 \cdot 3\text{H}_2\text{O}$  crystallizes in orthorhombic syngony, sp. gr. Cmcm,  $a = 11.6462(3)$ ,  $b = 13.9943(4)$ ,  $c = 16.9225(5)$  Å,  $V = 2758.04(13)$  Å<sup>3</sup>,  $Z = 4$ . The compound is isostructurally  $[(\text{NH}_2)_2\text{CSSC}(\text{NH}_2)_2]_2[\text{Os}^{\text{IV}}\text{X}_6] \text{X}_2 \cdot 3\text{H}_2\text{O}$  ( $\text{X} = \text{Cl}, \text{Br}$ ) [1].

In  $\alpha, \alpha$ -bis(dithiobisformamidinium) cation the S-S bond is single with a length of 2.0282 (12) Å. The cation assumes the most energetically favorable gauche-conformation, and thiocarbamide fragments retain a flat structure. The cations  $[(\text{NH}_2)_2\text{CSSC}(\text{NH}_2)_2]^{2+}$  and complex anions  $[\text{RuBr}_6]^{2-}$  form a system of hydrogen bonds with Br<sup>-</sup> ions and water molecules (Fig. 1). Two cations are combined in a cycle by two Br<sup>-</sup> ions, which form 4 hydrogen bonds with NH<sub>2</sub>-groups of cations. The cycles are linked to each other like water molecules by hydrogen bonds N-H...O...H-N (Fig. 2).



**Fig. 1.** Structure of  $[(\text{NH}_2)_2\text{CSSC}(\text{NH}_2)_2]_2[\text{RuBr}_6]\text{Br}_2 \cdot 3\text{H}_2\text{O}$



**Fig. 2.** The system of hydrogen bonds

**References**

[1] O.V. Rudnitskaya, E.V. Dobrokhotova, E.K. Kultyshkina, P.V. Dorovatovskii, V.A. Lazarenko, V.N. Khurstalev, *Inorganica Chimica Acta*, **2019**, *484*, 352-356.

Acknowledgements. This work was supported by the RUDN University Strategic Academic Leadership Program.

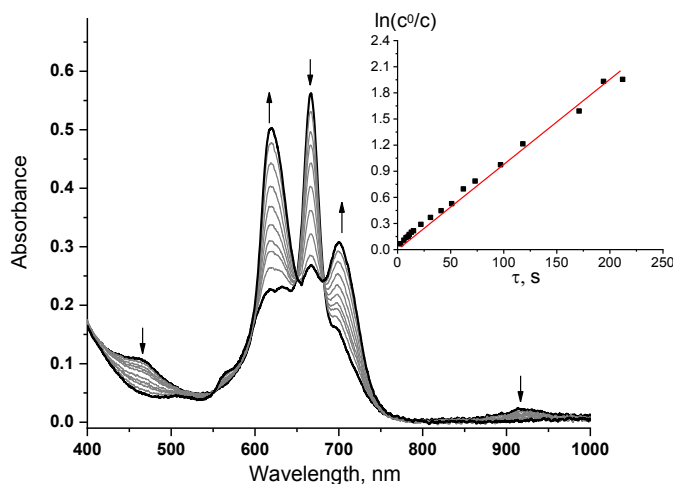
# REDOX-ACTIVE PHTHALOCYANINE SANDWICH COMPLEXES WITH RARE EARTH METALS AS PROMISING BIOSENSOR PROTOTYPES

*Domareva N.P.<sup>1</sup>, Alekseeva A.Yu.<sup>1</sup>, Botnar A.A.<sup>1</sup>, Erzunov D.A.<sup>1</sup>, Tikhomirova T.V.<sup>1</sup>, Vashurin A.S.<sup>1</sup>*

<sup>1</sup>Ivanovo State University of Chemistry and Technology, Ivanovo, Sheremetevsky Avenue, 7  
[domarevanat@gmail.com](mailto:domarevanat@gmail.com)

In recent decades, the chemistry of phthalocyanine complexes has developed intensively, where the most promising structures are sandwich molecules with lanthanide ions as a complexing metal [1]. In such complexes having two macrocyclic ligands, a strong  $\pi$ - $\pi$ -interaction is observed that allows electron transfer and is in several redox forms (neutral-radical, reduced, oxidized), which allows you to act as promising components of multi-color electrochromic displays, sensors and biosensors, conductor materials.

The use of diphthalocyanines of lanthanides with macromolecular structures is becoming promising in various fields and techniques. For example, high-sensitivity detection of albumin using diphthalocyanine-based sensory devices will diagnose inflammatory processes, diabetes mellitus, liver disease [2].



**Figure 1.** Changes in UV-vis for LuPc<sub>2</sub> in a THF solution ( $c = 1.2 \times 10^{-5}$  mol/L) in the presence of phenylhydrazine ( $c = 3.3 \times 10^{-4}$  mol/L) for 4 min. Insertion:  $\ln(c_0/c)$  versus the reaction time of LuPc<sub>2</sub> with phenylhydrazine.

Therefore, the purpose of this work is to study the kinetics of redox processes for homoleptic diphthalocyanine structures. It should be noted that there are few reports of kinetically controlled redox reactions involving diphthalocyanines in the literature. Thus, by the spectrophotometric method, the redox properties of double-deck phthalocyanine complexes of lanthanides (Er, Yb, Lu) were investigated depending on the ion radius of the metal (Fig.1). At the first stage, the aggregation behavior of complexes in solution was investigated. Next, the ability of sandwich structures to redox transitions with the addition of an oxidizing/reducing agent was spectrally studied. At the final stage, kinetic dependencies were established and an effective process constant was calculated [3].

It has been found that since the lutetium ion has the smallest radius, this leads to a stronger  $\pi$ - $\pi$  interaction of the two phthalocyanine ligands and, as a result, a more complete redox process with the addition of a reducing agent. On the other hand, ytterbium and erbium ions have a larger ion radius and a larger distance between macrocycles. This leads to the fact that the reduction process of diphthalocyanines proceeds more difficult with the formation of a mixture of neutral and anionic forms. A study of the kinetics of model reactions involving small redox-active agents and diphthalocyanines will predict their sensory properties for determining biologically important molecules, for example, albumin.

## References

- [1] Pushkarev, V.E et al. *Eur. J. Org. Chem.*, **2012**, 18(29), 9046–9055.
- [2] Lobanov, A. V., Gromova, G. A. et al. *Physical surface chemistry and material protection.*, **2014**, 50 (5), 465-465.
- [3] Erzunov, D. A., Botnar, A. A. et al. *Molecules*. **2021**, 26(8), 2181.

Acknowledgements. This work was supported by the Russian Science Foundation (project No 17-73-20017).

*Dubinina T.V.*<sup>1</sup>, *Gorbunova E.A.*<sup>1</sup>, *Kosov A.D.*<sup>1</sup>

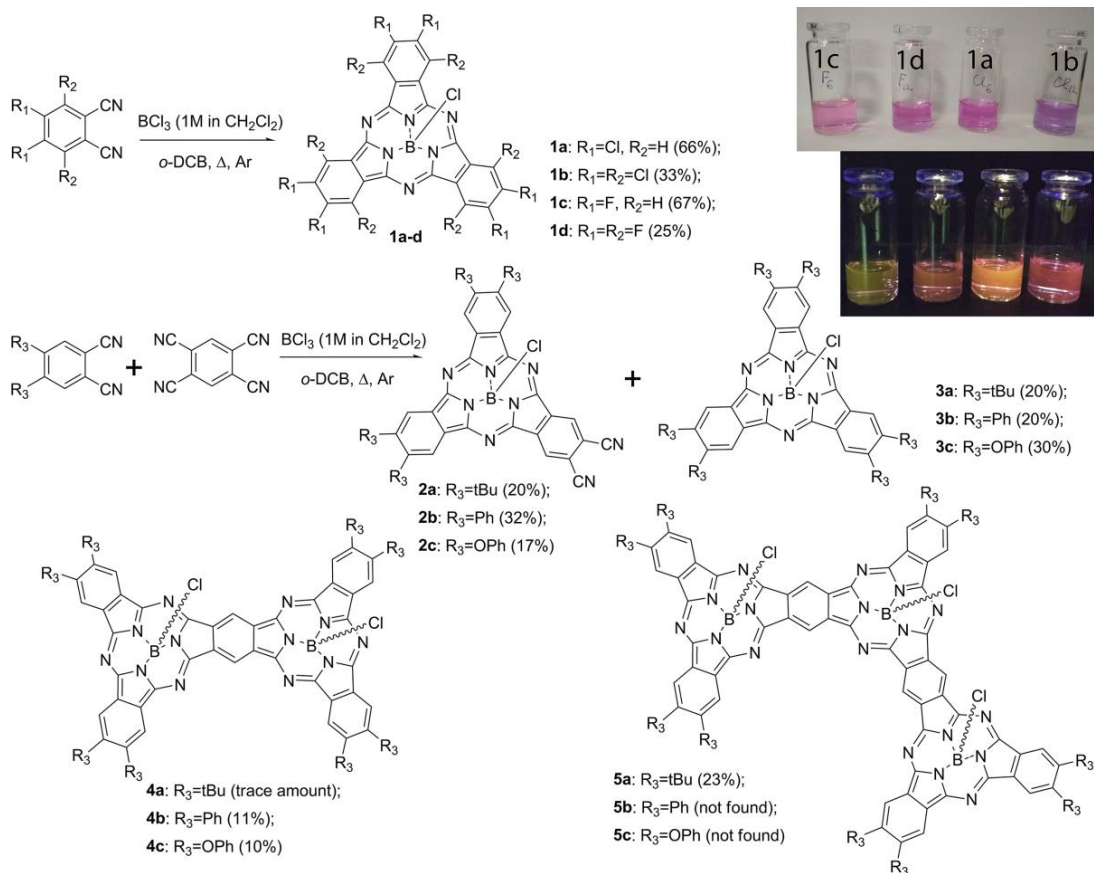
<sup>1</sup>Lomonosov Moscow State University, Moscow, Russia

PhD

[dubinina.t.vid@gmail.com](mailto:dubinina.t.vid@gmail.com)

Due to the high solubility in common organic solvents, intensive absorption and luminescence in visible region subphthalocyanines are prospective materials for photoactive layers of solar cells. Introduction of electron-withdrawing groups results in their high stability to oxidation by atmospheric oxygen.

Halogen-substituted subphthalocyanine complexes were obtained using modified template approach. Complexes **1a-d** show intense absorption and luminescence maxima, shifting bathochromically from 550 to 600 nm in a row **1c**<**1a**<**1d**<**1b**.



**Figure 1.** Synthesis of target boron subphthalocyanines.

Novel low symmetry A<sub>2</sub>B alkyl and aryl-substituted subphthalocyanines **2a-c**, containing reactive CN groups were obtained in relatively high yields using statistical condensation reaction. All by-products: mono- **3**, bi- (**4**) and trinuclear (**5**) complexes, were separated and characterized. A<sub>2</sub>B compounds **2a-c** can be further modified by cyclization with other substituted phthalonitriles. Nonlinear optical properties of compounds **1 - 3** were compared by Z-scan technique. A<sub>2</sub>B compounds demonstrate higher nonlinear response than symmetrically substituted ones.

**Acknowledgements.** The research was funded by RFBR and Moscow city Government according to the project № 21-33-70004.

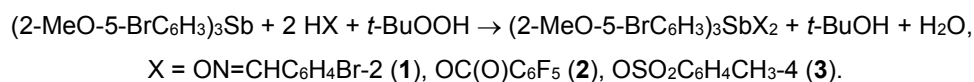
SYNTHESIS AND STRUCTURE OF *TRIS*(5-BROMO-2-METHOXYPHENYL)ANTIMONY DERIVATIVES  
(2-MeO-5-BrC<sub>6</sub>H<sub>3</sub>)<sub>3</sub>SbX<sub>2</sub> (X = ON=CHC<sub>6</sub>H<sub>4</sub>Br-2, OC(O)C<sub>6</sub>F<sub>5</sub>, OSO<sub>2</sub>C<sub>6</sub>H<sub>4</sub>CH<sub>3</sub>-4)

*Efremov A.N.*<sup>1</sup>, *Sharutin V.V.*<sup>1</sup>, *Sharutina O.K.*<sup>1</sup>

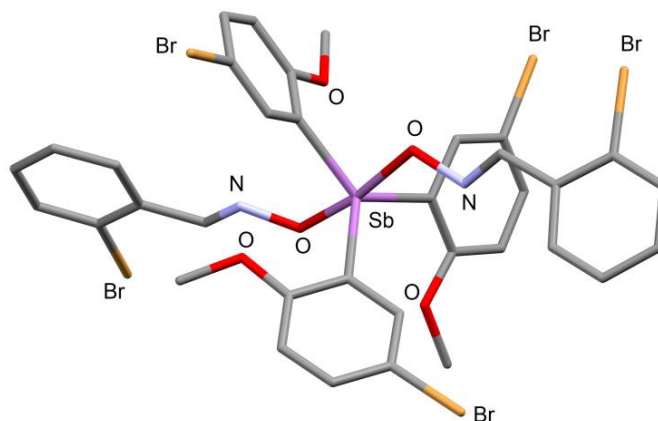
<sup>1</sup>South Ural State University (National Research University), Chelyabinsk, Russia  
PhD Student  
[efremov\\_an94@mail.ru](mailto:efremov_an94@mail.ru)

Of all the triarylantimony derivatives of the general formula Ar<sub>3</sub>SbX<sub>2</sub> (where X is an electronegative ligand bound to the antimony atom through a heteroatom), one of the least structurally characterized compounds are *tris*(5-bromo-2-methoxyphenyl)antimony derivatives [1].

*Tris*(5-bromo-2-methoxyphenyl)antimony *bis*(2-bromobenzaldoximate), *bis*(2,3,4,5,6-pentafluorobenzoate) and *bis*(4-methylphenylsulfonate) were obtained by the oxidative addition reaction from *tris*(5-bromo-2-methoxyphenyl) antimony, *tert*-butylhydroperoxide and, respectively, oxime, carboxylic acid or sulfonic acid at a molar ratio of reagents 1:1:2 in diethyl ether. After recrystallization of the solid residue from a benzene–octane (2:1) mixture, crystals suitable for X-ray diffraction analysis were obtained in a yield of up to 98%. This synthesis method is one-stage and is characterized by mild reaction conditions (20 °C, 12 h).



According to X-ray diffraction data, in molecules of *tris*(5-bromo-2-methoxyphenyl)antimony derivatives, antimony atoms have a distorted trigonal-bipyramidal coordination with oxygen atoms of oximate, carboxylate, and sulfonate ligands in axial positions (Figure 1). Triarylantimony sulfonate is a solvate (2-MeO-5-BrC<sub>6</sub>H<sub>3</sub>)<sub>3</sub>Sb(OSO<sub>2</sub>C<sub>6</sub>H<sub>4</sub>CH<sub>3</sub>-4)<sub>2</sub> · PhH (**3**) after recrystallization from benzene. In the triarylantimony dicarboxylate molecule, the -C<sub>6</sub>F<sub>5</sub> fragment is disordered over two positions with an atomic occupancy of 0.41/0.59.



**Figure 1.** Structure of compound 1.

Equatorial substituents in *tris*(5-bromo-2-methoxyphenyl)antimony dioximate are farther from the central atom than axial ones. The opposite is observed in triarylantimony disulfonate, while in the dicarboxylate the distance of the substituents from the antimony atom is practically the same. The antimony atom is deviated from the equatorial plane [C<sub>3</sub>] by 0.073 (**1**), 0.056 (**2**), and 0.051 (**3**) Å. Planar aryl rings are rotated around Sb–C<sub>eq</sub> bonds in such a way as to minimize intra- and intermolecular interactions. The OSbC axial angles deviate from 180° and are 169.1(1)° (**1**), 176.2(1)° (**2**) and 169.72(9)° (**3**). The obtained structures contain intramolecular contacts Sb···N=CH (**1**), Sb···O=C (**2**), Sb···O=S (**3**), as well as Sb···O(Me) contacts. The formation of the crystal structure of the compounds is due to the presence of hydrogen bonds of the type H···O=C, H···O=S, H···O–N, H···F, H···Br and CH–π-interactions.

#### References

[1] [www.ccdc.cam.ac.uk/structures](http://www.ccdc.cam.ac.uk/structures) (Cambridge Crystallographic Database. Release 2021. Cambridge).

Acknowledgements. This work was supported by Russian Foundation for Basic Research (project No 20-33-90099).

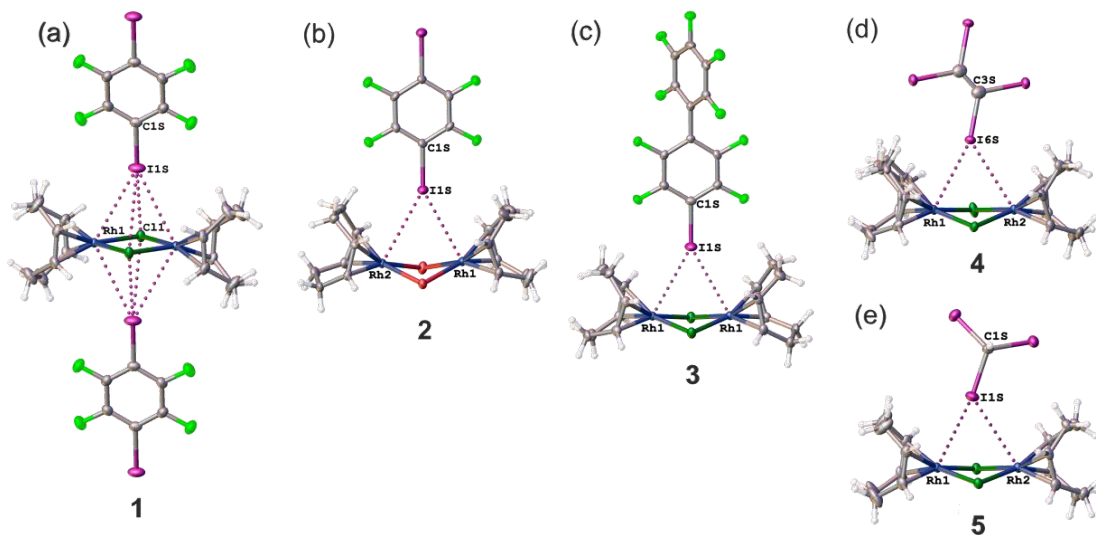
BIFURCATED HALOGEN BONDING INVOLVING TWO RHODIUM(I) CENTERS  
AS AN INTEGRATED XB ACCEPTOR

*Eliseeva A.A.*<sup>1</sup>

<sup>1</sup>Saint Petersburg State University, Saint Petersburg, Russia  
PhD, Research Fellow  
[a.a.eliseeva@spbu.ru](mailto:a.a.eliseeva@spbu.ru)

Halogen bonding (XB) — together with other types of noncovalent interactions — has exponentially emerged as an important concept in supramolecular design and crystal engineering, synthetic coordination chemistry, polymer science, XB-involving catalysis, medicinal chemistry, and human physiology. To date, metal-involving two-center XBs have been recognized for Ni<sup>II</sup>, Pd<sup>II</sup>, Pt<sup>II</sup>, Au<sup>0</sup>, and Au<sup>I</sup>. In a few instances, a M<sup>II</sup> center and the adjacent coordinated non-metal atom function as an integrated XB acceptor to give three-center bifurcated  $\mu_2$ -X $\cdots$ [Pt<sup>II</sup>,Cl] (X = Br, I) and  $\mu_2$ -I $\cdots$ [Pt<sup>II</sup>,C] linkages. In this work, we found that simultaneous action of the  $d_{z^2}$ -orbitals of two positively charged rhodium(I) centers provide sufficient nucleophilicity to form three-center XBs with  $\sigma$ -hole ( $\sigma_h$ ) donating iodine(I)-based organic species [1].

The [RhX(COD)]<sub>2</sub> (X = Cl, Br; COD = 1,5-cyclooctadiene) complexes were co-crystallized with various iodine(I)-based XB donors to give corresponding co-crystals **1–5** studied by single-crystal X-ray diffraction (XRD; Fig. 1). Upon analysis of noncovalent forces in the XRD structures of the obtained adducts, we recognized hitherto unknown Ar<sup>F</sup>( $\mu_4$ -I) $\cdots$ [Rh<sub>2</sub>Cl<sub>2</sub>] and R<sup>EWG</sup>( $\mu_2$ -I) $\cdots$ [Rh,Rh] XBs involving iodine centers of  $\sigma_h$  donors and [Rh<sub>2</sub>X<sub>2</sub>] metal cores of the rhodium(I) complexes (Fig. 1). We examined the geometric and energetic features of the detected contacts using the combined experimental and theoretical approaches. The noncovalent XB nature of the observed interactions was confirmed theoretically by the DFT calculations via several computational tools (QTAIM, DFT energies, NCI and EDD plots, MEP surfaces, ELF analysis).



**Figure 1.** The Ar<sup>F</sup>( $\mu_4$ -I) $\cdots$ [Rh<sub>2</sub>Cl<sub>2</sub>] and R<sup>EWG</sup>( $\mu_2$ -I) $\cdots$ [Rh,Rh] interactions in **1** (a), **2** (b), **3** (c), **4** (d), and **5** (e). The XBs are given by dotted lines and thermal ellipsoids are shown with the 50% probability.

In this work, we found the first example of the three-center XB that involves simultaneously two metal centers functioning as integrated XB acceptor toward iodine(I)-based  $\sigma_h$  donors. Moreover, we performed the assembly through two- or more metal-involving XBs exploring the potential of  $\cdots$ [Rh<sub>2</sub>Cl<sub>2</sub>] $\cdots$ I(Ar<sup>F</sup>) $\cdots$ [Rh<sub>2</sub>Cl<sub>2</sub>] $\cdots$  or tetrafurcated Ar<sup>F</sup>( $\mu_4$ -I) $\cdots$ [Rh<sub>2</sub>Cl<sub>2</sub>] interactions.

### References

[1] Eliseeva A.A., Ivanov D.M., Rozhkov A.V., Ananyev I.V., Frontera A., Kukushkin V.Yu. *JACS Au* **2021**, *1*, 356.

Acknowledgements. This work was supported by the Council for Grants of the President of Russian Federation (project MK-1614.2021.1.3).

# SYNTHESIS AND CRYSTAL STRUCTURES OF CYTOTOXIC MIXED-LIGAND MANGANESE(II) COMPLEXES WITH 5-PHENYLTETRAZOLE AND POLYPYRIDINE DERIVATIVES

*Ermakova E.A.*<sup>1,2,3</sup>, *Eremina J.A.*<sup>1,2,3</sup>, *Smirnova K.S.*<sup>1</sup>

<sup>1</sup>Nikolaev Institute of Inorganic Chemistry, SB RAS, Novosibirsk, Russia

<sup>2</sup>Novosibirsk State University, Russia

<sup>3</sup>Institute of Molecular Biology and Biophysics – Subdivision of FRC FTM, Novosibirsk, Russia

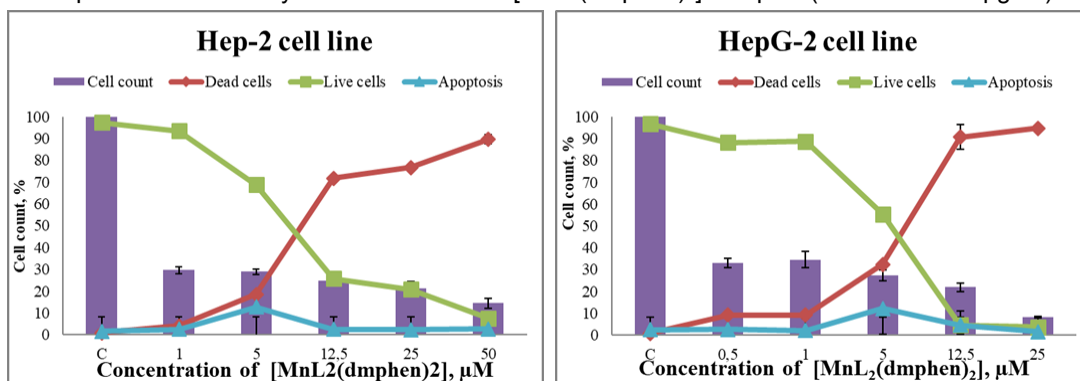
Student

[ermakova2299@gmail.com](mailto:ermakova2299@gmail.com)

Chemotherapy is one of the methods of oncological diseases treatment. Therefore, large scale studies are being carried out, the purpose of which is to create new anticancer drugs that have lower dose-dependent side effects in comparison with cisplatin and its analogues [1]. In particular, one of the promising classes of compounds is mixed-ligand complexes of endogenous metals with polypyridine ligands. There are data on mixed-ligand Cu(II) complexes based on 1,10-phenanthroline and its derivatives (Casiopeinas®), which have shown high cytotoxic activity [2]. An equally important factor for research is the biological activity of the ligands themselves. Tetrazoles are known pharmacophores that are capable of forming stable coordination bonds with metal ions. That is why the appropriate ligands were selected for research.

A series of mixed-ligand manganese(II) complexes  $[\text{Mn}_3(\text{phen})_2\text{L}_4(\text{OAc})_2]$  (**1**),  $[\text{Mn}_3(\text{bipy})_2\text{L}_4(\text{OAc})_2]$  (**2**),  $[\text{Mn}_2(\text{dmbipy})_2\text{L}_2(\text{OAc})_2]$  (**3**), and  $[\text{Mn}(\text{dmphen})_2\text{L}_2]$  (**4**), where L – 5-phenyltetrazolate anion, phen – 1,10-phenanthroline, bipy – 2,2'-bipyridine, dmbipy – 4,4'-dimethyl-2,2'-bipyridine, dmphen – 4,7-dimethyl-1,10-phenanthroline, has been synthesized. The complexes have been characterized by elemental and powder X-ray diffraction analysis, and IR spectroscopy. Crystal structures of complexes have been determined by single-crystal X-ray diffraction analysis. The UV-vis spectroscopy has been applied to study the behavior of the compounds in solution. The effect of the compounds on viability of HepG2 and Hep-2 cell lines has been investigated. The antimicrobial activity of complexes and ligands has been investigated against *Escherichia coli*, *Staphylococcus aureus*, *Penicillium italicum* and *Colpoda steinii*.

Although the ratio M:polypyridine:HL = 1:1:2 was used in the synthesis of complexes **1-4**, synthesized compounds have different composition: Mn(II) complexes **1, 2** – trinuclear with 3:2:4 ratio, Mn(II) complex **3** – binuclear with 1:1:1 ratio, in turn, Mn(II) complex **4** – mononuclear with 1:2:2 ratio. In the complexes listed above, HL act as monodentate (L, coordinated by N2 atom) or bidentate ligand (coordinated by N2 and N3 atoms) or even as a counterion. UV-vis spectroscopy has revealed that the complexes **1-4** are stable enough during 48h in water-ethanol solution. The cytotoxic activity of the ligands, metal salts and the obtained complexes was studied on the human cell lines *Hep-2* (laryngeal carcinoma cells) and *HepG2* (hepatocellular carcinoma cells) using an IN Cell Analyzer 2200 device (GE Healthcare, UK). Among the series of compounds, the most pronounced cytotoxic properties are exhibited by Mn(II) complex with 4,7-dimethyl-1,10-phenanthroline and 5-phenyltetrazole ( $\text{IC}_{50} = 5.7 \pm 0.6 \mu\text{M}$ , HepG2). Among polypyridine ligands, cytotoxic activity is observed only for 4,7-dimethyl-1,10-phenanthroline, but toxicity is enhanced in the complexes of Mn(II) with 5-phenyltetrazole. All complexes showed no fungistatic activity against *P. italicum* and no bacteriostatic activity against *St. aureus*. Slight inhibition of *E. Coli* growth compared to reference drugs was observed under the influence of complexes **1, 2** (inhibition zone  $\approx 7\text{-}10$  mm). In a series of complexes, the most pronounced protistocidal activity is observed for the  $[\text{MnL}_2(\text{dmphen})_2]$  complex ( $\text{C} = 5.6 \pm 0.15 \mu\text{g/ml}$ ).



**Figure 1.** Effect of complex  $[\text{MnL}_2(\text{dmphen})_2]$  (**4**) on the viability of Hep2 and HepG2 cells determined by dual staining with Hoechst 33342/propidium iodide

## References

- [1] D J Higby, H J Wallace Jr, J F Holland, *Cancer Chemother. Rep.* **1973**, 57. 459–463.
- [2] L Ruiz-Azuara, M E Bravo-Gómez, *Curr. Med. Chem.* **2010**, 17. 3606–3615.

Acknowledgements. This work was supported by the Russian Science Foundation (project № 20-73-10207).

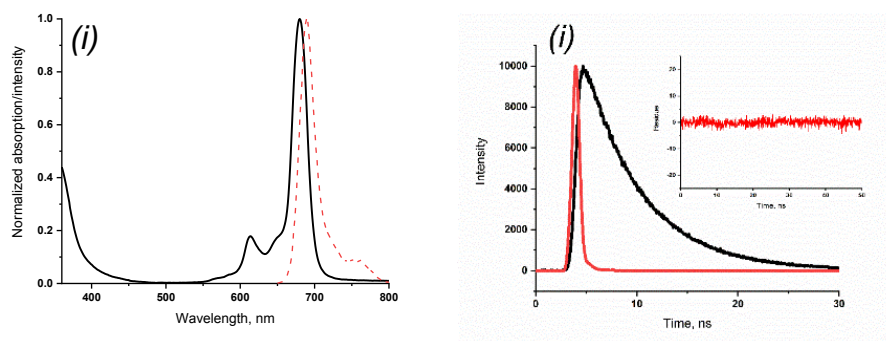
# SYNTHESIS AND STUDY OF THE SPECTROSCOPIC AND LUMINESCENT PROPERTIES OF DICYANOPHENOXYPTHALOCYANINE COMPLEXES OF DIFFERENT STRUCTURE WITH RARE-EARTH ELEMENTS

*Erzunov D.A.<sup>1</sup>, Vashurin A.S.<sup>1</sup>*

<sup>1</sup>Ivanovo State University of Chemistry and Technology, Ivanovo, Sheremetevsky Avenue, 7  
PhD Student  
[demon\\_erz@mail.ru](mailto:demon_erz@mail.ru)

Phthalocyaninates of rare-earth metals represent a special subgroup of compounds of this class due to the high specificity of the displayed properties, and, as a consequence, and the scope of their application [1]. The preparation of such complexes opens up the possibility of using luminescent active atoms due to the removal of quantum prohibitions on the manifestation of high-energy light emission processes, which, in turn, make it possible to use materials based on such compounds as highly efficient second-generation sensitizers [2-3]. The structure of the ligand used has a strong effect on the described properties of the resulting coordination compounds. Thus, an important factor is the modeling of the structure of the used ligand, taking into account the nature of the substituents for the full disclosure of the energy potential of the introduced luminescent active center.

The paper presents data on the preparation and study of the properties of rare-earth phthalocyaninates of mono- and double-deck structure with cyanophenoxyl- substitution at the periphery. Compounds were obtained by condensation in a high-boiling solvent and template fusion, and in the first case, the target objects were not detected due to the course of polymerization processes. The complexes were isolated and purified using column and gel permeation chromatography. The structure has been proven by NMR, IR spectroscopy, elemental analysis, MALDI-TOF mass spectrometry. The spectral properties were studied, the maximums of light absorption in the visible region and the extinction coefficients were found, and the concentration ranges of the aggregation stability of the complexes in various organic solvents were determined. For sandwich structures, the kinetics of redox processes occurring upon the addition of hydrazine or bromine has been studied, and the constants of these processes have been calculated. For monophthalocyaninates, the spectral-luminescent properties have been investigated, the quantum yields of fluorescence and its lifetimes have been determined. For complexes of both types, the effect of the structure of the peripheral substituent and the central metal atom on the properties is shown.



**Figure 1.** Absorption and emission spectra of lanthanide complexes (left) and fluorescent quenching (right) curve

## References

- [1] Platonova, Y.B., Volov, A.N., Tomilova, L.G. *J. Catal.* **2020**, *391*, 224-228.
- [2] Guo, J., Yan, X., Liu, Q., Li, Q., Xu, X., Kang, L., Cao, Z., Chai, G., Chen, J., Wang, Y. et al. *Nano Energy* **2018**, *46*, 347-355.
- [3] Erzunov, D.A., Botnar, A.A., Domareva, N.P., Tikhomirova, T.V., Vashurin, A.S. *Molecules* **2021**, *26*, 2181.

Acknowledgements. This work was supported by the Russian Science Foundation (project 17-73-20017).



SYNTHESIS AND STRUCTURAL STUDY OF NON-FLUORINATED MAGNESIUM BETA-DIKETONATE COMPLEXES WITH (O<sup>^</sup>N) AND (N<sup>^</sup>N)-DONOR NEUTRAL LIGANDS

*Evseev G.S.<sup>1,2</sup>, Vikulova E.S.<sup>1</sup>, Sukhikh A.S.<sup>1</sup>*

<sup>1</sup> Nikolaev Institute of Inorganic Chemistry, Novosibirsk, Russia

<sup>2</sup>Novosibirsk State University, Novosibirsk, Russia

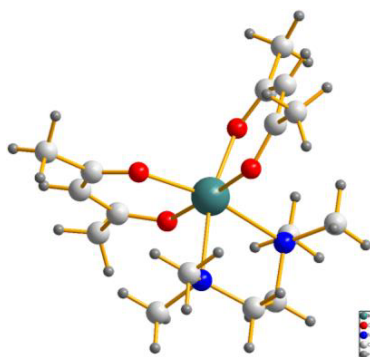
Student

[g.evseev@q.nsu.ru](mailto:g.evseev@q.nsu.ru)

Volatile magnesium complexes are demanded as precursors for the obtaining MgO thin films, manifesting a high secondary electron emission coefficient, by means of chemical vapor deposition (MOCVD). To prevent the formation of MgF<sub>2</sub>, such precursors must be fluorine-free. Typically, β-diketonate ligands provide an effective platform for the creation of volatile metal complexes. However, a magnesium atom in such an environment is coordinatively unsaturated, which leads to oligomerization and complicates the use of complexes as precursors. One of the solutions to this problem is mixed ligand complexation (MLC). This work develops research in the field of MLC magnesium with non-fluorinated β-diketonates: acetylacetonate ion (acac) and dipivaloylmethanate ion (dpm).

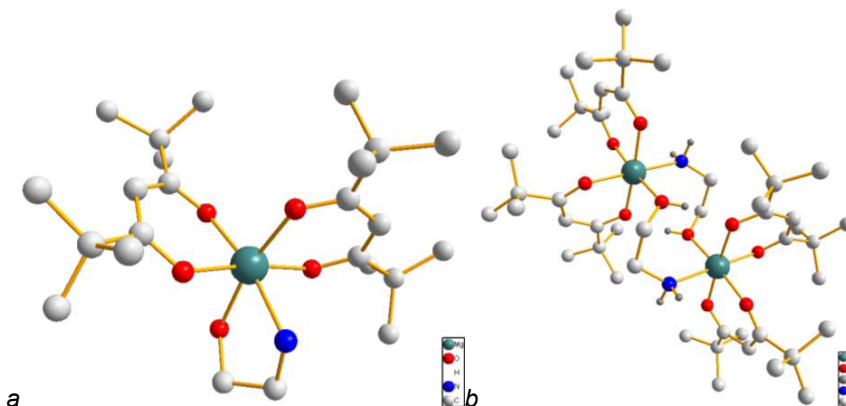
A new polymorphic modification [Mg(tmeda)(dpm)<sub>2</sub>] (tmeda = N,N,N',N'-tetramethylethylenediamine) was discovered, which explains the inconsistency of the rate of transfer of substance in the MOCVD process and the differences in the literature melting temperatures. The thermal properties of the new polymorph in the condensed phase were studied by DSC and the saturated vapor pressure was measured by the flow method. The phase composition of the product was studied depending on the purification method.

An approach was found to obtain [Mg(tmeda)(acac)<sub>2</sub>] (fig. 1), which turned out to be unstable on air. The related complex with 2,2'-bipyridyl (bipy) is stable in the condensed phase but decomposes in chloroform to form [Mg(acac)<sub>2</sub>]<sub>3</sub>. This was confirmed by 1H-NMR and XRD data of the [Mg(acac)<sub>2</sub>]<sub>3</sub>·2CHCl<sub>3</sub> precipitate.



**Figure 1.** Structure of [Mg(tmeda)(acac)<sub>2</sub>]

For the first time, complexes [Mg(Q)(dpm)<sub>2</sub>] with amino alcohols were obtained: Q = dmae (N,N-dimethylaminoethanol), mae (aminoethanol) by the substitution reaction of aqua ligands in [Mg(H<sub>2</sub>O)<sub>2</sub>(dpm)<sub>2</sub>]. The synthesis of the complex with dmae occurs in hexane, and the excess in stoichiometry of amino alcohol can be included in the composition of the forming crystals due to hydrogen bonds with the [Mg(dmae)(dpm)<sub>2</sub>] molecules. For the synthesis of [Mg(mae)(dpm)<sub>2</sub>], amino alcohol must be used as a solvent. The complex can have both mononuclear and binuclear structures due to the bridging functions of mae ligands (fig. 2).



**Figure 2.** Structures of mononuclear (a) and binuclear (b) [Mg(mae)(dpm)<sub>2</sub>]

# SYNTHESIS OF OCTAHEDRAL BROMIDE CLUSTER COMPLEXES OF TUNGSTEN FROM ELEMENTARY SUBSTANCES

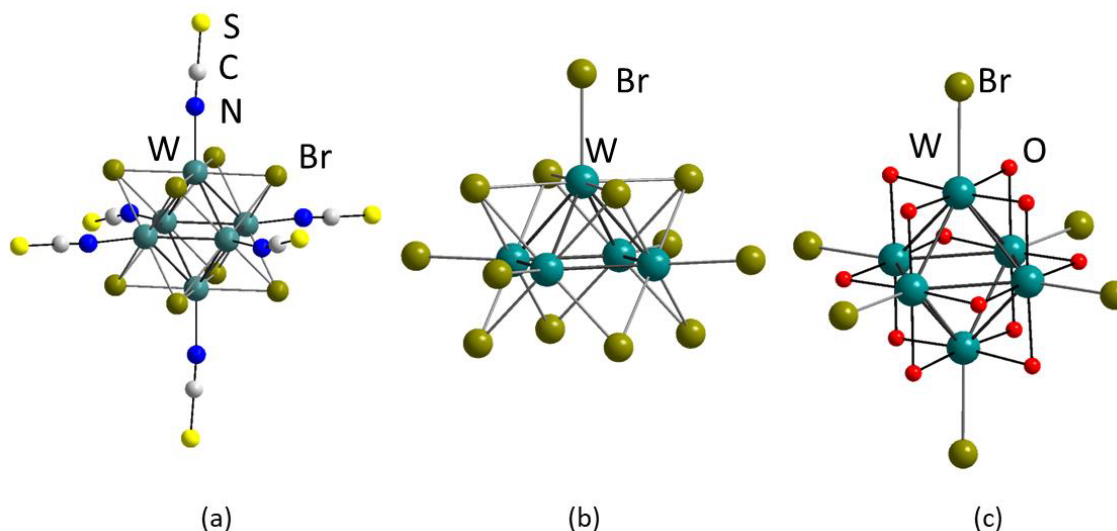
*Evtushok D.V.*<sup>1</sup>

<sup>1</sup>NIIC SB RAS, Novosibirsk, Russia

PhD Student

[evtushok@niic.nsc.ru](mailto:evtushok@niic.nsc.ru)

The luminescence of high-Z octahedral cluster complexes  $[M_6X_8L_6]^{2-}$  ( $M = Mo, W$ ;  $X = Cl, Br, I$ ;  $L =$  organic or inorganic ligand) is quenched by molecular oxygen with the formation of singlet oxygen  $^1O_2$ . This feature can potentially be used in blue-light or X-ray-induced photodynamic therapy [1] and antibacterial coatings [2]. Molybdenum clusters are more studied than tungsten ones since effective methods of synthesis from simple substances have been developed for them [3]. There are several main methods of obtaining tungsten bromide cluster complexes. The first is a multi-step method based on the reduction of  $WBr_5$  with elementary tungsten or aluminum to  $WBr_4$ , followed by thermolysis to polymer  $[W_6Br_8Br_4]_n$  [4]. The second method is the reduction of  $WBr_6$  with bismuth yielding compound  $(BiBr_2)_2W_6Br_{14}$ . However,  $WBr_6$  is obtained from  $W(CO)_6$ , which significantly increases the cost of the process [5]. The third method involves the direct interaction of stoichiometric amounts of elementary substances of tungsten and bromine at high temperatures, which requires special equipment using a two-zone furnace [6]. Therefore, we have developed a new synthesis method of  $(N(C_4H_9)_4)[W_6Br_{14}]$  from W, Br, Bi to develop the chemistry of tungsten bromide cluster complexes.



**Figure 1.** The structure of anion  $[W_6Br_8(NCS)_6]^{2-}$  (a),  $[W_5Br_{13}]^-$  (b),  $[W_6O_{12}Br_6]^{8-}$  (c).

The report discusses a new approach to the synthesis of bromide cluster complexes with the anion  $[W_6Br_8Br_6]^{2-}$  from simple substances. A mixture of pentanuclear cluster complexes  $[W_5Br_{13}]^-$  and  $[W_5Br_{13}O]^-$  is formed as by-products. Substitution of external bromide ligands is discussed. The synthesis of a cluster complex with a new type of cluster core  $\{W_6O_{12}\}^{2-}$  is reported.

## References

- [1] Kirakci K. et al. *Inorg. Chem.* **2020**, 59, 13, 9287–9293
- [2] Vorotnikova, N. A. et al. *Mater. Sci. Eng. C* **2019**, 105, 110150
- [3] Kirakci K., et al. *Z. Anorg. Allg. Chem.* **2005**, 631, 2-3, 411–416
- [4] McCarley R.E. et al. *Inorg. Chem.* **1964**, 3, 9, 1232.
- [5] Stroebele M. et al. *Z. Anorg. Allg. Chem.* **2010**, 636, 9-10, 1817.
- [6] Yarovoi S. et al. *Russ. J. Coord. Chem.*, **2012**, 38, 6, 402.

Acknowledgements. This work was supported by Russian Foundation for Basic Research (project No 19-53-12019).

# PASSAGE OF A GAS BUBBLE THROUGH THE BOUNDARY OF TWO IMMISCIBLE LIQUIDS ON THE EXAMPLE OF THE MATTE-SLAG SYSTEM

*Amdur A.M.<sup>1</sup>, Fedorov S.A.<sup>2</sup>*

<sup>1</sup>Ural State Mining University, Ekaterinburg, Russia

<sup>2</sup>Institute of Metallurgy UrB RAS, Ekaterinburg, Russia

Postgraduate student

[saf13d@mail.ru](mailto:saf13d@mail.ru)

The passage of a gas bubble through the interface of two immiscible liquids is poorly understood. During the period of passing this boundary, the bubble can capture and float a drop of a heavier liquid. The process is considered on the example of the matte - slag boundary, and the conditions for the matte drop to float up together with the bubble are established. This is of practical importance, since it is known that the transfer of matte droplets into slag by flotation is one of the main processes leading to losses of valuable metals during pyrometallurgical processing of sulfide ores, including platinum and gold, which are in matte and slag in the form intermetallic compounds [1]. Irregularly shaped particles of intermetallic compounds of gold and platinum, containing impurities of various metals, and found in the surface layers of the slag, are associated with floating matte droplets. Gold and platinum are dispersed. Their sizes are 5-7 microns and in rare cases reach 20 microns. Evaluation of adhesion at the interface between a drop of Au-matte and a solid particle of Pt-matte showed that this value is high and comparable, for example, with the calculated values for Fe-Cr.

In order for the bubble to "tear off" the matte droplet from the sulfide melt and float up with it in the slag, two conditions must be met. 1. The droplets are held on the bubbles by interfacial tension, which can be called the cohesion force. To prevent the drop from breaking away from the bubble, the adhesion force of the matte drop with the bubble must be greater than its gravity. 2. The buoyant force applied to the bubble must be greater than the gravity of the drop. Otherwise, the droplet bubble will sink.

Evaluation of the interfacial tension at the matte boundary required to calculate the adhesion force of a matte drop with a bubble was carried out on the basis of photographs obtained with a Tescan Vega 3 scanning electron microscope after cooling from a temperature of 1300°C of platinum sulfide and gold-containing materials. The photographs were also used to determine the angles characterizing the interphase boundaries.

Calculations showed that for the slag and matte we studied experimentally, the maximum possible radius of a matte droplet held by the cohesion force on the surface of the gas bubble is about 4 mm. The size of the bubble that lifts the matte drop can be even smaller than its size. The possible sizes of floating matte droplets are very significant, which is consistent with the noticeable loss of valuable components.

## References

[1] Amdur A., Selivanov E., Fedorov S., Pavlov V., Krasikov S. *Journal of Mining and Metallurgy, Section B: Metallurgy*. **2021**, 57 (2), 209-215.

Acknowledgements. This research work was carried out supported by the RFBR grants No. 18-29-24081\20 and No. 19-38-90080\19.

# HYBRID PHOSPHORUS AND NITROGEN-BASED LIGANDS FOR NICKEL CATALYZED ETHYLENE OLIGOMERIZATION

Gafurov Z.N.<sup>1</sup>, Soficheva O.S.<sup>1</sup>, Yakhvarov D.G.<sup>1,2</sup>

<sup>1</sup>Arbuzov Institute of Organic and Physical Chemistry, FRC Kazan Scientific Center, Kazan, Russia

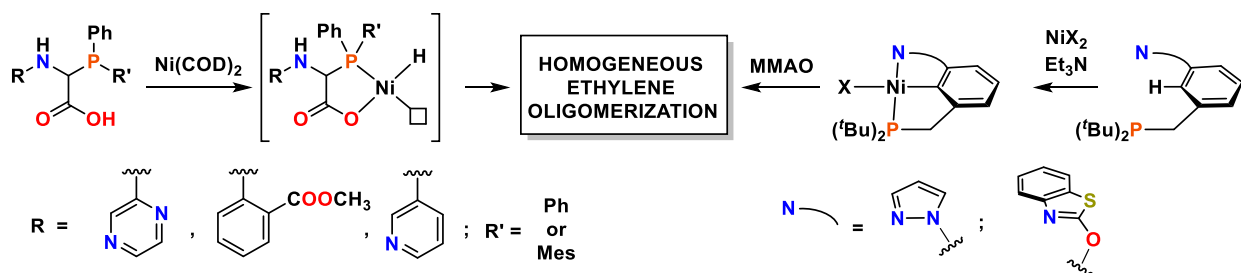
<sup>2</sup>Kazan Federal University, Alexander Butlerov Institute of Chemistry, Kazan, Russia

Young Scientist

[zufargo@gmail.com](mailto:zufargo@gmail.com)

Transition metal complexes based on hybrid chelate ligands have unique properties due to the combination of hard (for N-side) and soft (for P-side) electron-donors. In such species, the difference in the donor properties between the two different ligand arms provide the hemilability of the ligand since the group with the weak interaction with the metal center being more likely to dissociate from the metal center, which lead to a vacant coordination site at the metal center and so can allow for effective coordination and transformation of substrate molecules in the homogeneous catalysis conditions [1].

Thus, in this study, we have prepared different types of hybrid phosphorus and nitrogen-based ligands: the N- and P- substituted  $\alpha$ -phosphinoglycine derivatives [2] and unsymmetrical benzothiazole- or pyrazole-based PCN pincer systems [3] (see figure 1). The obtained ligands are able to react with nickel precursor to form active species, which oligomerize ethylene into a wide range of even-numbered olefins (mainly C<sub>4</sub>-C<sub>30</sub> fractions).



**Figure 1.** Hybrid phosphorus and nitrogen-based ligands for nickel catalyzed ethylene oligomerization.

Moreover, DFT calculations were performed to explore the mechanism of ethylene oligomerization catalyzed by generated organonickel active species. The obtained results revealed that the steric influence of the ligand plays the key role on the nickel catalyzed ethylene oligomerization. Thus, when  $\alpha$ -phosphino- $\alpha$ -amino acids are applied as ligands, sterically less loaded substituents are required both at the phosphorus and nitrogen atoms in order to obtain low molecular weight ethylene oligomers. Thereby, *N*-(pyrazin-2-yl)- $\alpha$ -diphenylphosphinoglycine was found to be selective to but-1-ene, with turnover number (TON) value 2493.

While, preliminary activated complexes ( $\text{BzTzPCN}$ )NiX (X = F, Br) containing an oxo-bridged benzothiazole side-arm demonstrated high catalytic activity in ethylene oligomerization (up to  $200 \times 10^3 \text{ mol}_{\text{C}_2\text{H}_4} \cdot \text{mol}_{\text{Ni}}^{-1} \cdot \text{h}^{-1}$ ) with formation of butenes as main products. The comparison of their performance with the results obtained for more rigid pyrazole-based analogues ( $\text{PyrPCN}$ )NiX (X = F, Br) demonstrates a positive effect of the flexibility modification of the ligand and reduced N-donor basicity, which favors dissociation of the N-side arm and its rotation around the bond connecting the two pincer sides. The benzothiazole side-arm remains uncoordinated, generating a vacant coordination site which is a prerequisite for the obtainment of a more active catalyst [4].

## References

- [1] Gafurov Z.N., Kagilev, A.A., Yakhvarov D.G. et al. *Russ. Chem. Bull.* **2018**, 67, 385–394.
- [2] Soficheva O.S., Yakhvarov D.G. et al. *Mendeleev Commun.* **2019**, 29, 575–577.
- [3] Luconi L., Gafurov Z.N., Yakhvarov D.G. et al. *ACS Omega* **2019**, 4, 1118–1129.
- [4] Gafurov Z.N., Kagilev A.A., Yakhvarov D.G. et al. *J. Organomet. Chem.* **2020**, 912, 121163.

Acknowledgements. This work was supported by Russian Foundation for Basic Research (project No 19-29-08051).

COORDINATION COMPOUNDS BASED ON NEW TETRANUCLEAR VANADIUM FRAGMENT  $\{V_4OSe_8I_6\}$ :  
SYNTHESIS, STRUCTURE AND PROPERTIES

Galiev R.R.<sup>1</sup>

<sup>1</sup>Nikolaev Institute of Inorganic Chemistry, Novosibirsk, Russia

PhD student

[galiev@niic.nsc.ru](mailto:galiev@niic.nsc.ru)

Transition metal chalcogenide halides (TMCH) are the coordination compounds with formula of  $M_xQ_yHal_z$ , where M = transition metal (M = Mo, W, Re, Nb etc.), Q = S, Se, Te, Hal = F, Cl, Br, I. Frequently oxygen is included in composition. Vanadium in coordination compounds can form ions with different electronic configurations which corresponds to intermediate oxidation states, which may be interesting as from new formation of a new structures point of view, as from magnetic and electro-physical properties perspective. However, despite the variety of structures of TMCH in the literature at the moment only one vanadium chalcogenide halide is described – thiobromide  $V_4S_9Br_4$  [1]. To expand the list of vanadium chalcogenide halides ( $V_xQ_yHal_z$ ) we've started the search for new compounds in this systems and firstly in the «V-Se-I» system.

In the present work a series of synthesis were performed to obtain new vanadium selenide iodides by reaction between elements and known binary compounds in evacuated ampoules.

As a result of a work a series of a new coordination vanadium oxide selenide iodides with the same O-centered tetranuclear complex  $\{V_4(\mu_4-O)(\mu_2-Se_2)_4(\mu_2-I)_2I_4\}$  were obtained. The resulting complexes are presented by compounds with various dimensionalities of coordination array – 0D, 1D, 2D. Complex core  $\{V_4OSe_8I_6\}$  is new for chemistry of vanadium. In the center of complex a  $V_4O$  is located, in which vanadium atoms occupy the vertex positions of distorted tetrahedral around oxygen. Between themselves vanadium atoms additionally bonds by four bridging  $\mu_2-Se_2$  groups and two bridging  $\mu_2-I$  groups. In the present work the synthesis, structures of a new vanadium oxide selenide iodides with same structural fragment  $\{V_4OSe_8I_6\}$ , results of DFT calculations of complex core and magnetic properties for some of the obtained compounds are discussed

#### References

[1] Mironov Y.V., Yarovoi S.S., Naumov D.Y., Kozlova S.G., Ikorsky V.N., Kremer R.K., Simon A. and Fedorov V.E. *Journal of Physical Chemistry B*, **2005**, *109*, 23804-23807.

Acknowledgements. This work was supported by the Russian Science Foundation (project No 21-13-00274)

NEW SOLID SOLUTIONS OF  $\text{La}_{1-x}\text{RE}_x\text{Ga}_{0.5}\text{Sb}_{1.5}\text{O}_6$  (RE = Ce, Eu, Tb, Dy, Er, Tm)  
FOR LUMINESCENT APPLICATIONS

*Golodukhina S.V.*<sup>1</sup>, *Veselova V.O.*<sup>1</sup>, *Gajtko O.M.*<sup>1</sup>, *Svetogorov R.D.*<sup>2</sup>, *Egorysheva A.V.*<sup>1</sup>

<sup>1</sup>Kurnakov institute of general and inorganic chemistry RAS

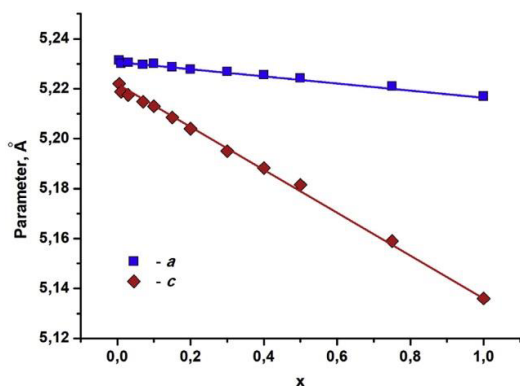
<sup>2</sup>National Research Centre "Kurchatov Institute"

PhD student

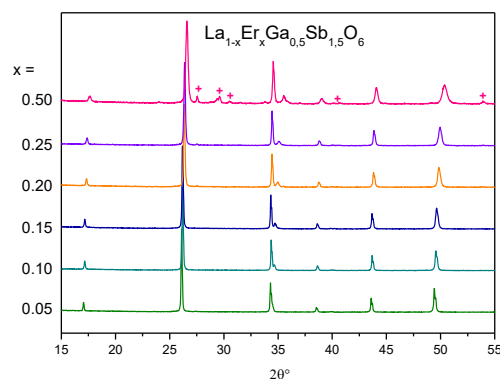
[brightorangedandelion@gmail.com](mailto:brightorangedandelion@gmail.com)

Solid solutions based on the complex oxide  $\text{La}_{1-x}\text{RE}_x\text{Ga}_{0.5}\text{Sb}_{1.5}\text{O}_6$  are promising phosphors for visible light LED [1,2]. The complex oxide  $\text{LaGa}_{0.5}\text{Sb}_{1.5}\text{O}_6$  belongs to the structural type of rosielite, in which  $\text{La}^{3+}$  ions are located in octahedral voids between layers formed by  $(\text{Ga}/\text{Sb})\text{O}_6$  octahedra connected in six-membered rings (fig. 1). A feature of this structure is the large distance between  $\text{La}^{3+}$  ions, which reduces the probability of nonradiative energy transfer from an excited to an unexcited ion and increases the threshold concentration of luminescence quenching. With a decrease in the ionic radius  $R$  of the REE in the  $\text{LnGa}_{0.5}\text{Sb}_{1.5}\text{O}_6$  series, the distance between the layers of the  $(\text{Ga}/\text{Sb})\text{O}_6$  octahedra decreases and the structure becomes destabilized, as a result of which the existence of this series of compounds is possible only at RE = La-Tb. In this case, the change in the lattice parameter with RE radius decreasing is much weaker. The aim of this work was to investigate the possibilities of isovalent substitution of  $\text{LaGa}_{0.5}\text{Sb}_{1.5}\text{O}_6$  with different RE.

To synthesize phosphors for white light sources, it is necessary to create  $\text{La}_{1-x}\text{Ln}_x\text{Ga}_{0.5}\text{Sb}_{1.5}\text{O}_6$  solid solutions, in which different RE ions are used as activators. We have successfully synthesized a continuous series of single-doped solid solutions  $\text{La}_{1-x}\text{RE}_x\text{Ga}_{0.5}\text{Sb}_{1.5}\text{O}_6$  (RE = Ce - Tb,  $x = 0 - 1$ ), as evidenced by a monotonous decrease in the lattice parameters. Ions of the end of the REE series (Dy, Er, Tm), that don't form  $\text{REGa}_{0.5}\text{Sb}_{1.5}\text{O}_6$ , are perspective activators for LED but their insertion leads to discontinuous solid solutions. For solid solutions Ln = Dy or Er we obtained single-phase samples only at an Ln content of 5 to 25 mol. %, failed to synthesize solid solutions with an Er content of 50 mol. % (fig. 2). For Tm doped samples we observed impurities starting with 15% Tm. This result can not be explained only in terms of a decrease of the average RE ionic radius. It was assumed that the stability of the rosielite layered structure is provided by electrostatic stabilization by strong polarization of O-anions by  $\text{Sb}^{5+}$  ions [3]. We suppose that the rosielite layered structure destabilization occurs not only due to a general decrease in the distance between the  $(\text{Ga}/\text{Sb})\text{O}_6$  layers of the crystal lattice, but also due to the arising structural distortions when the rare-earth ions of a small radius (Dy, Er, Tm) are located in neighboring positions.



**Figure 1.** Lattice parameter change for continuous solid solutions  $\text{La}_{1-x}\text{Pr}_x\text{Ga}_{0.5}\text{Sb}_{1.5}\text{O}_6$



**Figure 2.** XRD patterns of discontinuous solid solutions  $\text{La}_{1-x}\text{Er}_x\text{Ga}_{0.5}\text{Sb}_{1.5}\text{O}_6$

Thus we have found that the possibilities of doping complex  $\text{La}_{1-x}\text{Ln}_x\text{Ga}_{0.5}\text{Sb}_{1.5}\text{O}_6$  oxide with small REE ions are significantly limited. At the same time, we managed to obtain solid solutions of double, in which we were able to achieve RE concentrations up to 5% Dy, 5% Tm in one sample and triple doping up to 4% Eu, 7% Tb, 7% Tm. Nevertheless, the enclosed REE concentration limits exceed those required for practical application of these compositions as luminescent materials.

**References**

- [1] Egorysheva, A. V. *et al. Ceram. Int.* **2019**, *45*, 16886–16892
- [2] Egorysheva, A. V. *et al. J. Lumin.* **2021**, *232*, 117869.
- [3] Egorysheva, A. V. *et al. J. Alloys Compd.* **2019**, *777*, 655–662.

Acknowledgements. This work was supported by the Russian Foundation for Basic Research (project No 18-29-12009) and performed using the equipment of the JRC PMR IGIC RAS.

## SOPHISTICATED TRANSFORMATIONS OF HETEROSPIN COMPLEX

*Golomolzina I.V.*<sup>1</sup>, *Tolstikov S.E.*<sup>1</sup>, *Romanenko G.V.*<sup>1</sup>, *Letyagin G.A.*<sup>1</sup>, *Bogomyakov A.S.*<sup>1</sup>, *Ovcharenko V.I.*<sup>1</sup>

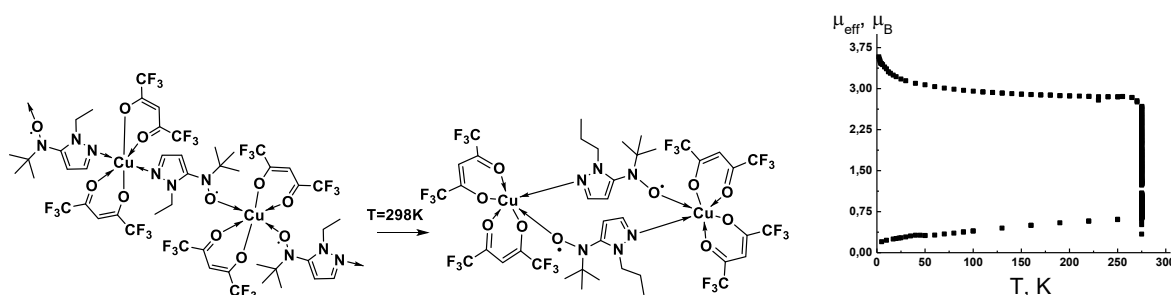
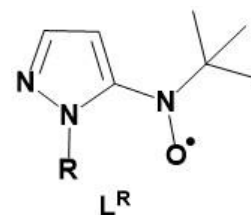
<sup>1</sup> International Tomography Center SB RAS, Novosibirsk, Russia

Research Assistant

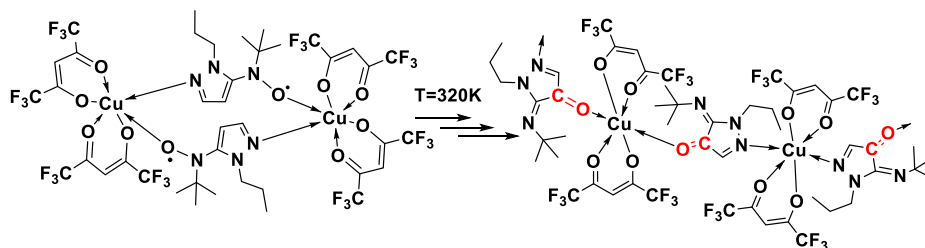
[i.golomolzina@tomo.nsc.ru](mailto:i.golomolzina@tomo.nsc.ru)

We succeeded in synthesizing a series of 1-R-5-(N-tert-butyl-N-oxylamino)-pyrazoles L<sup>R</sup> (R = Me, Et, n-Pr, i-Pr, n-Bu). The reaction of [Cu(hfac)<sub>2</sub>] with L<sup>R</sup> gives rise to a variety molecular and polymeric chain heterospin complexes.

Chain polymeric [Cu(hfac)<sub>2</sub>L<sup>Et</sup>] at room temperature undergoes to irreversible solid-phase transformation into binuclear [Cu(hfac)<sub>2</sub>L<sup>Et</sup>]<sub>2</sub> (Figure 1). In case of complex [Cu(hfac)<sub>2</sub>L<sup>nPr</sup>]<sub>2</sub> the heating provokes a series of sophisticated transformations into the chain polymeric [Cu(hfac)<sub>2</sub>L<sup>nPr</sup>«O»] containing coordinated diamagnetic pyrazolone L<sup>nPr</sup>«O» (Figure 2). It is the first example of such transformation for copper-nitroxide complexes.



**Figure 1.** Phase transition of [Cu(hfac)<sub>2</sub>L<sup>Et</sup>] into [Cu(hfac)<sub>2</sub>L<sup>Et</sup>]<sub>2</sub>, dependence  $\mu_{\text{eff}}(T)$ .



**Figure 2.** The solid-phase transformation [Cu(hfac)<sub>2</sub>L<sup>nPr</sup>]<sub>2</sub> into [Cu(hfac)<sub>2</sub>L<sup>nPr</sup>«O»].

### References

- [1] Ovcharenko V. I., Maryunina K. Yu., Fokin S. V., Tretyakov E. V., Romanenko G. V., Ikorskii V. N. *Rus. Chem. Bull.* **2004**, 11, 2406
- [2]. Tretyakov E. V., Tolstikov S.E., Suvorova A. O., Polushkin A. V., Romanenko G. V., Bogomyakov A. S., Veber S. L., Fedin M. V., Stass D. V., Reijerse E., Lubitz W., Zueva E. M., Ovcharenko V. I. *Inorg. Chem.* **2012**, 51, 9385–9394
- [3]. Fokin S. V., Kostina E. T., Tretyakov E. V., Romanenko G. V., Bogomyakov A. S., Sagdeev R. Z., Ovcharenko V. I. *Rus. Chem. Bull.* **2013**, 3, 661-671.

Acknowledgements. This work was supported by the Russian Science Foundation (project 18-13-00380)

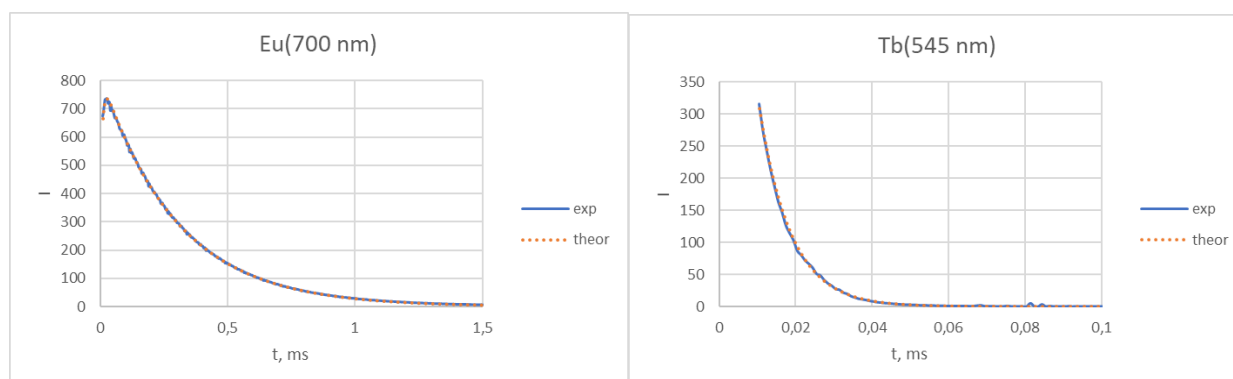
MIXED-METAL LANTHANIDE COMPLEXES WITH CH<sub>3</sub>-,CF<sub>2</sub>H- AND CF<sub>3</sub>-SUBSTITUED 1,3-DIKETONES:  
KINETIC ASPECTS OF ENERGY TRANSFER BETWEEN EU<sup>3+</sup> AND TB<sup>3+</sup>

*Gontcharenko V.E.*<sup>1</sup>, *Belousov Yu.A.*<sup>1,2</sup>, *Taydakov I.V.*<sup>2</sup>

<sup>1</sup>M.V. Lomonosov Moscow State University, Saint Petersburg, Russia  
<sup>2</sup>P.N Lebedev Physical Institute of Russian Academy of Sciences, Moscow, Russia  
Student  
[victo.goncharenko@gmail.com](mailto:victo.goncharenko@gmail.com)

Mixed-metal lanthanide complexes represent a relatively new field of objects that are actively studied due to their application as color-tunable emitters, white light sources, luminescent thermometers and chemical sensors. The performance of these materials is determined by the efficiency and kinetic parameters of excitation energy transfer in the ligand-lanthanide<sup>1</sup>-lanthanide<sup>2</sup> system, and the efficiency of energy transfer from one lanthanide ion to another depends significantly on the distance between metal atoms in the structure.

In this work, we have synthesized a series of mixed-metal complexes [(Ln<sup>1</sup><sub>x</sub>Ln<sup>2</sup><sub>1-x</sub>L<sup>1-3</sup><sub>3</sub>(H<sub>2</sub>O)<sub>2</sub>], where Ln<sup>1</sup>, Ln<sup>2</sup> = Eu, Tb, Gd, and HL<sup>1</sup> = 1-(1,5-dimethyl-1H-pyrazol-4-yl)-1,3-butanedione, HL<sup>2</sup> = 1-(1,5-dimethyl-1H-pyrazol-4-yl)-4,4-difluoro-1,3-butanedione [1], HL<sup>3</sup> = 1-(1,5-dimethyl-1H-pyrazol-4-yl)-4,4,4-trifluoro-1,3-butanedione. Small distance between the lanthanide ions in the structure and the behaviour of lanthanide luminescence decay curves indicate presence of excitation energy transfer from Tb<sup>3+</sup> to Eu<sup>3+</sup>. A model of one-sided energy transfer was developed and used in order to take into account the energy transfer in the fitting of the decay curves, which led to a precise description of the experimental data.



**Figures 1,2.** Correspondence of the developed fitting model to the experimental data, using data for complex [Eu<sub>0.25</sub>Tb<sub>0.75</sub>L<sup>2</sup><sub>3</sub>(H<sub>2</sub>O)<sub>2</sub>] as an example.

#### References

[1] V.E.Gontcharenko, M.A. Kiskin, V.D Dolzhenko, V.M. Korshunov, I.V. Taydakov, Y.A. Belousov. *Molecules*, **2021**, 26, 2655.

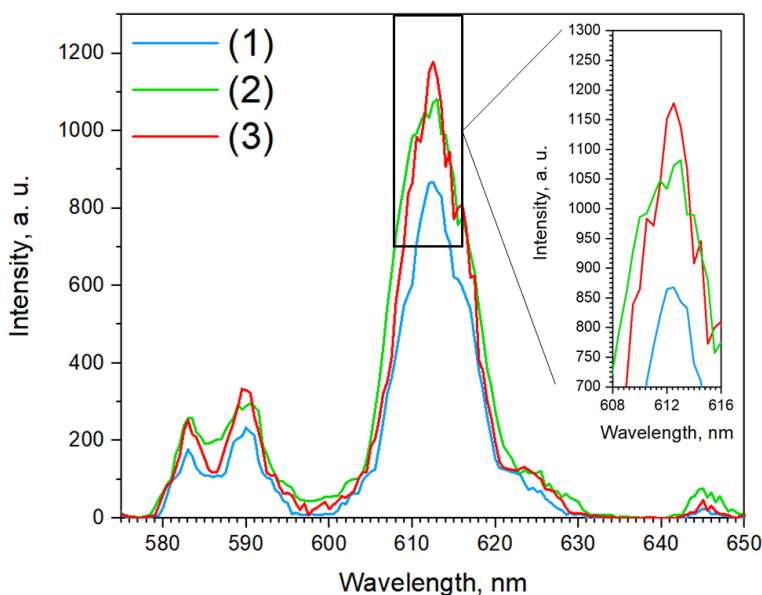
Acknowledgements. This work was supported by the Russian Foundation for Basic Research (project № 20-33-70208).



Luminescent materials are an integral part of many manufacturing industries such as LEDs, monitors, glowing paints and many more. Organo-inorganic hybrids based on layered rare-earth hydroxides are one of the new promising materials for the manufacture of phosphors. These compounds have become popular because of their increased photostability relative to organic phosphors and their increased excitation range relative to inorganic phosphors. In this work, the dependence of the photoluminescence intensity of an organic-inorganic composite based on Gd-Eu on the content of Eu ions in the system was investigated.

Layered Gd-Eu hydroxides were synthesized using controlled double-jet precipitation at a constant pH = 8 [1] with the molar ratio of europium ions to the total content of rare earth ions in the layered hydroxide of 0.01; 0.1 and 0.15. After precipitation, the suspension was filtered, and the precipitate was washed with distilled water and absolute isopropyl alcohol. The washed precipitate was dried at 50 °C for 24 hours. 2 g of the dried precipitate was intercalated in 1 dm<sup>3</sup> of a solution of sodium salt of terephthalic acid with a concentration of 0.042 mol/dm<sup>3</sup>. Intercalation was carried out in an autoclave at a temperature of 90 °C for 24 hours. After intercalation, suspension and sediment in it were subjected to the same treatment as after precipitation.

The synthesized hybrids were investigated by photoluminescence spectrometry with excitation by UV radiation with a wavelength of 256 nm.



**Figure 1.** The photoluminescence spectrum of hybrids containing 1 (1), 10 (2) and 15 mol. % (3) Eu ions.

The maximum photoluminescence intensity occurs at a wavelength of 612 nm. With an increase in the content of Eu ions, the intensity of photoluminescence also increases, despite the fact that the intensity of luminescence of similar oxide systems begins to decrease after the content of Eu ions is more than 10 mol% [2]. Further work will be aimed at studying the mechanism of energy transfer in the system and at expanding the range of the content of Eu ions.

#### References

- [1] Gordeev E.V., Mashkovtsev M.A., Berseneva M.A., Baksheev E.O., Zhirenkina N.V., Buynachev S.V. *AIP Conference Proceedings* **2020**, 2313, 050011  
 [2] Mashkovtcev M.A., Aleshin D.K., Gordeev E.V., Buinachev S.V., Kuznetsova Y.A. *AIP Conference Proceedings* **2019**, 2174, 020039

Acknowledgements. Authors thank Minobrnauki project FEUZ-2020-0059 for financial support.

# VANADIUM(V) COMPLEXES WITH CARBOHYDRATES AND ALCOHOLS

*Gorkusha G.V.<sup>1</sup>, Fedorishkina A.A.<sup>1</sup>, Ruzanov D.O.<sup>1</sup>*

<sup>1</sup>Saint Petersburg State Institute of Technology (Technical University), Saint Petersburg, Russia

Student

[Grigorygor2014@yandex.ru](mailto:Grigorygor2014@yandex.ru)

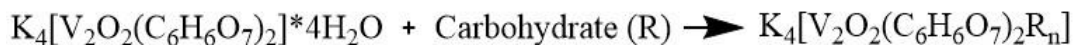
It is known that vanadium complexes are insulin-mimetics that affect the components of enzymes responsible for carbohydrate metabolism in the body. This is due to the effect of vanadium compounds on the activity of glucose-6-phosphate dehydrogenase. [1]

Until now, the mechanism and reactions of the interaction of vanadium-containing complexes with carbohydrates and their phosphate derivatives remain unclear. The use of complex compounds of vanadium (IV), (V) is promising due to their stability, low toxicity, and they can also be easily excreted from the body. [2]

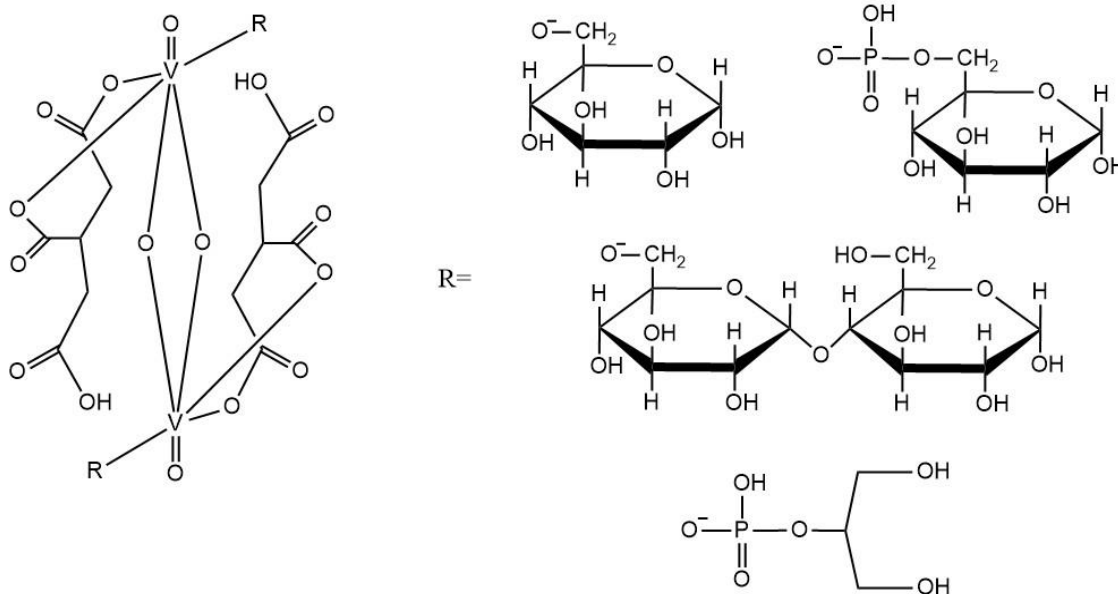
In this work we studied the interaction of vanadium citrate complex  $K_4[V_2O_2(C_6H_6O_7)_2] \cdot 4H_2O$  (1) with carbohydrates of various structures - glucose, maltose, and phosphorus-containing compounds - carbohydrate glucose-6-phosphate and alcohol -  $\beta$ -glycerophosphate.

The interaction of aqueous solutions of carbohydrates and complex 1 at pH ~ 6-7 led to the production of complex compounds of vanadium (V). Each complex was isolated as a colored crystalline powder from aqueous solutions containing the original complex and a dissolved carbohydrate. The solutions were kept at 25°C; after a few days, crystalline precipitates formed on the bottom and walls of the vessels. The interaction with phosphate-containing alcohols occurs in a similar way. All the compounds obtained have good solubility in water and are insoluble in organic solvents and are air-stable.

By IR-spectroscopy, UV-spectrometry, <sup>1</sup>H and <sup>13</sup>C NMR, CHN-analysis was found, that the binuclear citrate complex of vanadium (IV) is not destroyed during the reaction and is capable of oxidizing to the citrate complex of vanadium (V), forming complex compounds with carbohydrates. [Fig.1] According to the studies carried out, the complexes have the composition  $K_4[V_2O_2(C_6H_6O_7)_2R_n]$ , n=1-2. [Fig. 2]



**Figure 1.** General reaction.



**Figure 2.** Resulting compounds.

### References:

- [1] Lucy Marzban and John H. McNeill. *The J. of Trace Elem. in Exp. Med.* **2003**, 16, 253–267  
 [2] Sudeep Bhattacharyya, Alan S. Tracey. *J. Inorg. Biochem.* **2001**, 85, 9–13

CHIRAL TITANIUM(IV) AND VANADIUM(V) SALEN COMPLEXES AS CATALYSTS  
FOR CARBON DIOXIDE AND EPOXIDE COUPLING REACTIONS

*Gorodishch I.V.*<sup>1</sup>

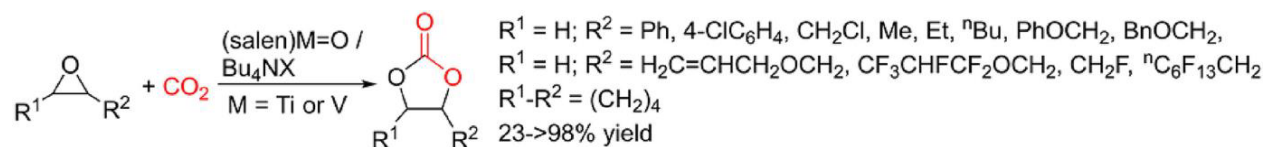
<sup>1</sup>Moscow State University, Moscow, Russia

Student

[ilia.gorodishch@chemistry.msu.ru](mailto:ilia.gorodishch@chemistry.msu.ru)

Chiral titanium(IV) and vanadium(V) salen complexes were found to catalyse the synthesis of cyclic carbonates from carbon dioxide and epoxides. Reactions could be conducted at room temperature and 50 bar pressure of carbon dioxide or at 100°C and atmospheric pressure with catalyst concentrations as low as 0.1 mol% and co-catalyst (tetrabutylammonium bromide) concentrations as low as 0.5 mol%. The cyclic carbonates formed were racemic and a mechanism is proposed which relies on Lewis base catalysis to activate the carbon dioxide rather than Lewis acid catalysed activation of the epoxide as more commonly proposed for catalysis by metal complexes

Keywords: salen ligand; carbon dioxide; cyclic carbonate; vanadium; titanium



**Figure 1.** Formation of cyclic carbonates from carbon dioxide and epoxides.

#### References

[1] Svetlana A. Kuznetsova, Iliia V. Gorodishch, Alexander S. Gak, Valeria V. Zhrebtsova, Igor S. Gerasimov, Michael G. Medvedev, Dinara Kh. Kitaeva, Ekaterina A. Khakina, Michael North, Yuri N. Belokon, *Tetrahedron* **2021**, 82

PROTONATED FORM OF TRIS(2,6-DIMETHOXYPHENYL)ANTIMONY OXIDE

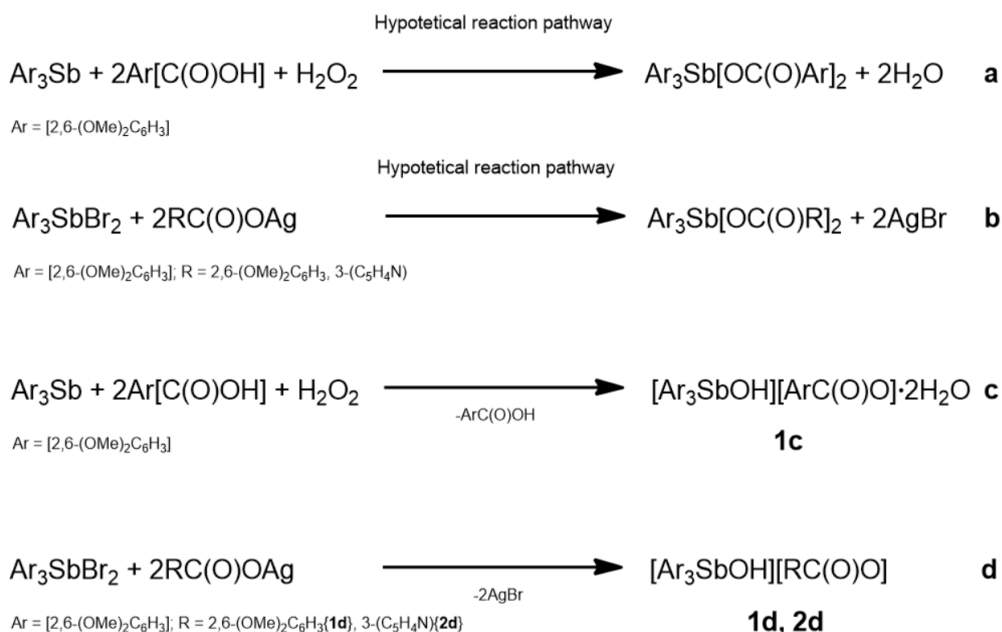
*Grinishak I.P.*<sup>1</sup>, *Egorova I.V.*<sup>1</sup>

<sup>1</sup> Blagoveshchensk State Pedagogical University, Amur Region, Blagoveshchensk, Russia  
[grinishak@mail.ru](mailto:grinishak@mail.ru)

Some organoantimony(V) acylates show the antibacterial, antifungal, antitumor activities. That's have been of great interest to researchers studying the organoantimony(V) compounds [1–3]. Also it may be used to synthesize amides [4].

Exchange reaction between organoantimony(V) dihalides and silver carboxylates or three-component reaction (oxidation addition) of organoantimony(III) with hydrogen peroxide / organic peroxide and Brønsted acid is often used to study of this compounds [5].

We have attempted to synthesize *tris*(2,6-dimethoxyphenyl)antimony biscalboxylates (Fig. 1; Scheme **a**, **b**).



**Figure 1.** Reaction scheme for the synthesis of *tris*(2,6-dimethoxyphenyl)antimony acylates and *tris*(2,6-dimethoxyphenyl)hydroxoantimony acylates

Monocarboxylate complexes were obtained instead of the expected triaryl antimony dicarboxylates (Fig. 1; Scheme **c**, **d**). All complexes displays an anionic part, the deprotonated carboxylic group and a cationic part, the protonated *tris*(2,6-dimethoxyphenyl)antimony.

The structure of **1c**, **1d**, **2d** was established by infrared spectroscopy. Molecular weights of two complexes determined by cryoscopic method suggest that they are monomeric and undissociated in CHCl<sub>3</sub>. Structure of **1c** characterized by X-ray monocrystal diffraction. The antimony atoms display a defective tetrahedral (ranges in bond angles CSbC 105.45(14)-116.81(15)° and CSbO 97.34(13)-109.36(13)°) environment with additional intra-ion Sb...O (shortest intramolecular contact 2.864 Å) contacts.

### References

- [1] Gupta R., Mathur M., Swami A.K., Sharma J., Singh Y. *Journal of Saudi Chemical Society*. **2017**, *21*, 67–75.
- [2] Islam A., Da Silva J.G., Berbet F.M., Da Silva S.M., Rodrigues B.L., Beraldo H., Melo M.N., Frézard F., Demicheli C. *Molecules*. **2014**, *19*, 5, 6009–6030.
- [3] Wang G-C, Lu Y-N, Xiao J, Yu L, Song H-B, Li J-S, Cui J-R, Wang R-Q, Ran F-X *J. Organomet. Chem.* **2005**, *690*, 151–156.
- [4] Nomura R., Wada T., Yamada Y., Matsuda H. *Chem. Lett.* **1986**, *15*, 11, 1901–1904.
- [5] Egorova I.V., Zhidkov V.V., Grinishak I.P., Rodionova N.A. *Zh. Obshch. Khim. Russ. J. Gen. Chem.* **2016**, *86*, 11, 2484–2491.

## ADDITION OF 2-PYRIDYLSELENYL HALIDES TO UNACTIVATED NITRILES

*Grishina M.M.*<sup>1</sup>, *Matsulevich Z.V.*<sup>2</sup>, *Borisov A.V.*<sup>2</sup>, *Khrustalev V.N.*<sup>1</sup>, *Tskhovrebov A.G.*<sup>1</sup>

<sup>1</sup>RUDN University, Moscow, Russia

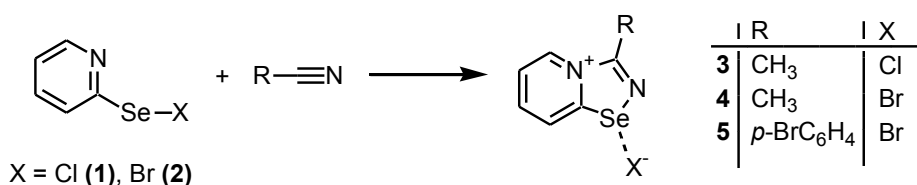
<sup>2</sup> Nizhny Novgorod State Technical University, Nizhny Novgorod, Russia

PhD Student

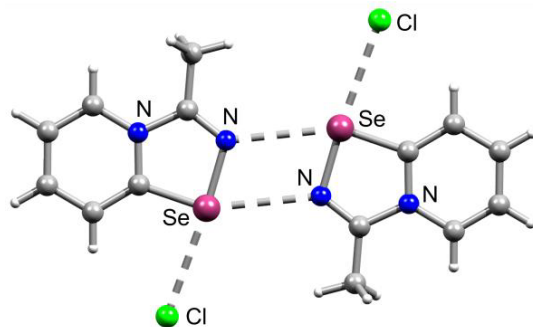
[mmgri@yandex.ru](mailto:mmgri@yandex.ru)

Nitriles are important building blocks that are widely used both in the laboratory and industry. Electrophilic or nucleophilic additions or asymmetric dipolar cycloaddition to the triple bond of nitriles are often an indispensable tool for the creation of various functionalities [1-3]. However, utilization of nitriles in organic synthesis is often difficult due to their inert nature, which even allows some of their related compounds to be applied as synthesis media. Efficient electrophilic (or nucleophilic) activation of nitriles can be achieved upon their coordination to electron-poor, high-oxidation-state (or electron-rich, low-valent) metal centers [2,4].

Here we report that 2-pyridylselenyl halides undergo facile coupling with a triple CN bond of unactivated nitriles (Figure 1).



**Figure 1.** Synthesis of **3-5**.



**Figure 2.** Ball-and-stick representation of crystal structure of **3**, demonstrating attractive Se...N interactions. Grey and light-grey spheres represent carbon and hydrogen, respectively.

Unprecedented heterocyclization allowed the preparation of novel class of cationic 1,2,4-selenadiazoles in remarkably high yields. Cationic 1,2,4-selenadiazoles form supramolecular dimers in the crystal via Se...N chalcogen bonding (Figure 2) [5].

### References

- [1] Kukushkin V.Y., Pombeiro A.J.L. *Chem. Rev.* **2002**, *102*, 1771–1802.
- [2] Gothelf K. V, Jørgensen K.A. *Chem. Rev.* **1998**, *98*, 863–910.
- [3] Tskhovrebov A.G., Bokach N.A., Haukka M., Kukushkin V.Y. *Inorg. Chem.* **2009**, *48*, 8678–8688.
- [4] Fairlie D.P., Jackson W.G., Skelton B.W., Wen H., White A.H., Wickramasinghe W.A., Woon T.C., Taube H. *Inorg. Chem.* **1997**, *36*, 1020–1028.
- [5] Khrustalev V.N., Grishina M.M., Matsulevich Z.V., Lukyanova J.M., Borisova G.N., Osmanov V. K., Novikov A.S., Kirichuk A.A., Borisov A.V., Solari E., Tskhovrebov A.G. *Dalton Transactions.* **2021**, *accepted*.

**Acknowledgements.** This work was supported by the Ministry of Education and Science of the Russian Federation (award no. 075-03-2020-223 (FSSF-2020-0017)) and the RUDN University Strategic Academic Leadership Program. Funding for this research was provided by Russian Foundation for Basic Research (project number 20-53-00006) and Belarusian Foundation for Fundamental Research (grant X20P-066).

# ARYL- AND HETEROARYL GOLD(I) ISOCYANIDE COMPLEXES: SYNTHESIS VIA BORON-TO-GOLD TRANSMETALLATION, STRUCTURES AND SELF-ASSEMBLY DUE TO AUROPHILIC INTERACTIONS

Grudova M.V.<sup>1</sup>, Tskhovrebov A.G.<sup>1,2</sup>

<sup>1</sup>People Friendship University of Russia, Moscow, Russia

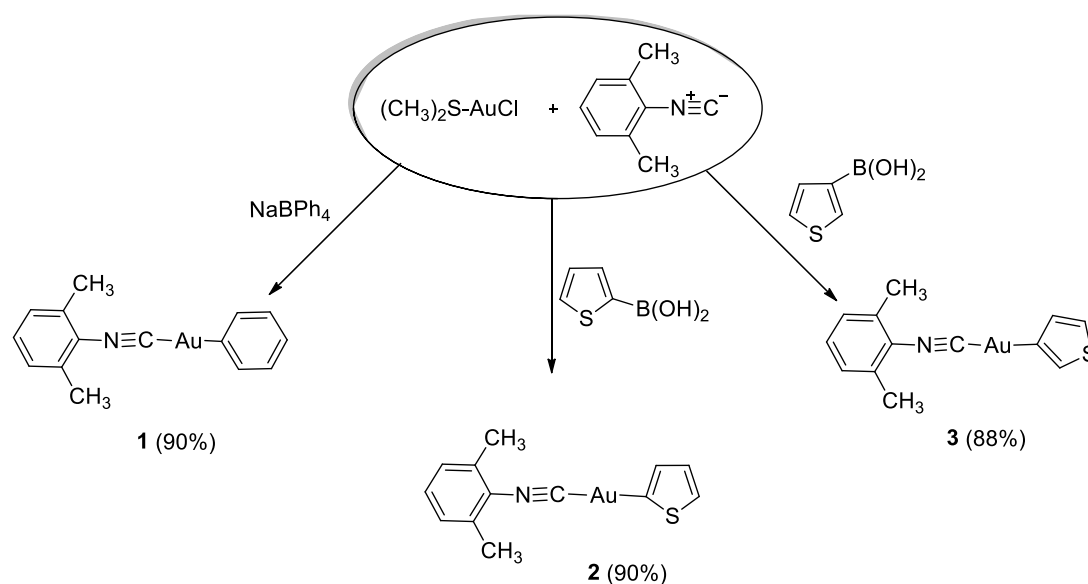
<sup>2</sup>FCCP RAS, Moscow, Russia

Student

[grudovamv@gmail.com](mailto:grudovamv@gmail.com)

Recently, isocyanide gold complexes attracted attention due to their intriguing photophysical properties. Luminescent gold(I) isocyanide complexes can be potentially used as sensors, probes and memory devices. [1]

Here we present a facile and efficient method for the preparation of gold(I) isocyanide compounds in high yields under mild conditions. In previous works, similar isocyanide gold complexes were prepared from organometallic Mg [1] or Li [2] precursors under inert atmosphere and subzero temperatures. Here we describe a more convenient procedure: all reactions were performed at room temperature under air. In most cases, target gold(I) isocyanide complex was easily isolated by slow crystallization in excellent yields (Figure 1).



**Figure 1.** Preparation of gold(I) isocyanide complexes.

Novel approach allowed us to prepare several new aryl- and heteroaryl gold(I) isocyanide complexes. Interestingly, the latter organogold(I) isocyanide complexes were found to exist in several polymorphic modifications in the solid state. Crystallization of complexes under various conditions afforded different polymorphs: dimeric, trimeric, tetrameric or even higher nuclearity forms. Self-assembly in the solid state was driven by the aurophilic interactions between gold(I) centers.

## References

- [1] Seki T., Sakurada K., Ito H. *Angewandte Chemie* **2013**, *125*, 13062-13066
- [2] Seki T., Kobayashi K., Ito H. *Chemical communications* **2017**, *53*, 6700-6703

**Acknowledgements.** This work was supported by the Russian Foundation for Basic Research (project number 20-53-00006) and Belarusian Foundation for Fundamental Research (grant X20P-066). Funding for this research was provided by Ministry of Science and Higher Education of the Russian Federation (award no. 075-03-2020-223 (FSSF-2020-0017)) and the RUDN University Strategic Academic Leadership Program.

# SYNTHESIS, STRUCTURE AND THERMAL PROPERTIES OF SILVER(I) BETA-DIKETONATES WITH BULKY TERMINAL SUBSTITUENTS AND THEIR CYCLOOCTADIENE DERIVATIVES

*Gulyaev S.A.*<sup>1,2</sup>, *Sukhikh T.S.*<sup>1</sup>, *Ilyin I.Yu.*<sup>1</sup>, *Vikulova E.S.*<sup>1</sup>

<sup>1</sup> Nikolaev Institute of Inorganic Chemistry, Novosibirsk, Russia

<sup>2</sup>Novosibirsk State University, Novosibirsk, Russia

Student

[themw3style@gmail.com](mailto:themw3style@gmail.com)

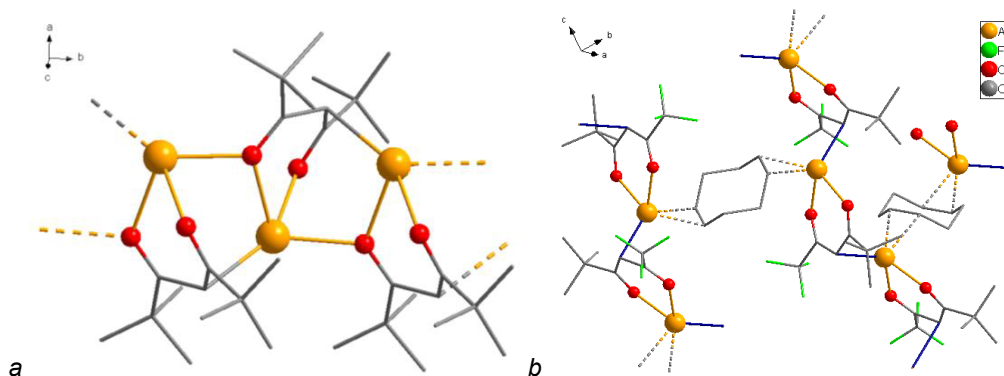
Silver films and nanoparticles are the most commonly used metal antibacterial agents. This gives rise to interest in the development of effective methods for their deposition onto the objects of nonplanar geometry, such as medical implants. It has been recently shown that the traditional wet chemistry methods can lead to the inclusion of impurities in the material composition, which affect the observed biological characteristics [1]. The promising alternatives are metal-organic chemical vapor deposition (MOCVD) and related methods.

However, MOCVD of silver-containing materials is much less developed than for other noble metals [2]. The most likely reason is a very limited set of silver volatile compounds (precursors) that meet the requirements for thermochemical properties. The main problem is the trend the form polymer structures of Ag(I) complexes with anionic ligands that traditionally used for MOCVD precursors (beta-diketonates, carboxylates). Polymeric compounds usually exhibit low volatility and thermal stability.

To reduce the structure dimensionality, the introduction of bulky substituents into the anionic ligand and/or additional neutral ligands are proposed. In this work, we implement both approaches for silver(I) complexes with beta-diketonate ligands (RC(O)CHC(O)R'). The aim was to reveal the influence of the modification of ligands and metal coordination environment on the structure and thermal properties of the complexes.

First, a series of monoligand beta-diketonate Ag complexes with C(CH<sub>3</sub>)<sub>3</sub>, C(OCH<sub>3</sub>)(CH<sub>3</sub>)<sub>2</sub> and C<sub>2</sub>F<sub>5</sub> substituents instead of common CF<sub>3</sub>, CH<sub>3</sub> were produced. These compounds were characterized by elemental CHN analysis, <sup>13</sup>C-NMR and FT-IR spectroscopy, single crystal XRD. It was shown that the introduction of bulky terminal substituents in diketonate ligand transforms the layered polymeric structures (2D) to chain coordination polymers (1D). The structural organization of the chains depends on combination of substituents, but the Ag-C bonds are typical for all the structures (Fig. 1a). Inclusion of solvent molecules (MeCN, PhMe) to fill Ag coordination sphere is also characteristic for these compounds. TGA has shown that the structure with the longest Ag...Ag distances (the least tense) is the most thermally stable.

For some beta-diketonates, heteroligand Ag complexes with 1,5-cyclooctadiene (cod) were prepared. If Ag(beta-dik):cod ratio is 1:1, these complexes are molecular; if this ratio is 2:1, the layered coordination polymers are formed due to bridge function of cod-ligand (Fig. 1b).



**Figure 1.** Ag(I) coordination polymers: (a)  $[Ag(tBuCOCHCOtBu)]_{\infty}$  (b)  $[Ag_2(cod)(tBuCOCHCOCF_3)_2]_{\infty}$ . Hydrogen atoms are omitted for clarity.

## References

[1] Aderibigbe, B. A. *Molecules* **2017**, *22*(8), 1370

[2] Piszczek, P., Radtke, A. In *Noble and Precious Metals - Properties, Nanoscale Effects and Applications*; Seehra, MS, Bristow, AD, Eds, **2018**, 187-213.

Acknowledgements. The research is supported by the grant of the President of the Russian Federation for Young Scientists MK-6148.2021.1.3.

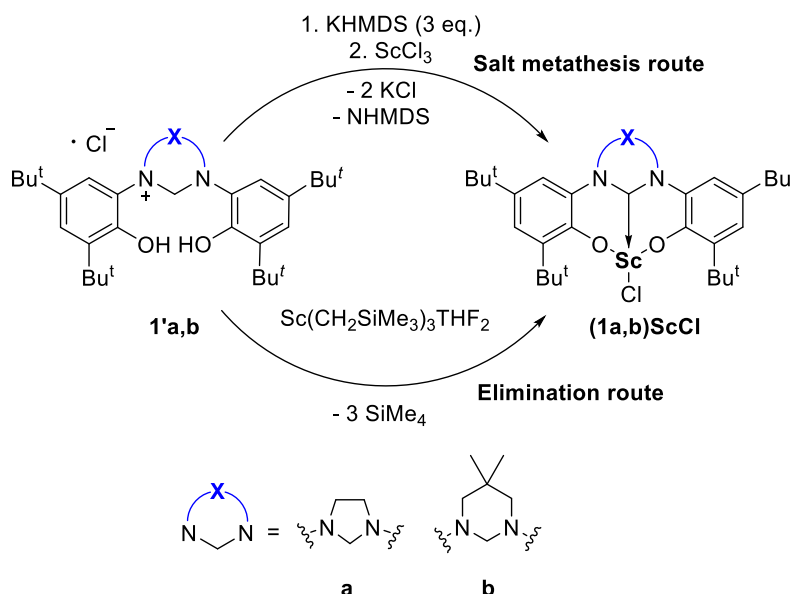
<sup>1</sup>National Research Lobachevsky State University of Nizhny Novgorod, Nizhny Novgorod, Russia<sup>2</sup>G.A. Razuvaev Institute of Organometallic Chemistry of Russian Academy of Sciences, Nizhny Novgorod, Russia<sup>3</sup>A.N. Nesmeyanov Institute of Organoelement Compounds of Russian Academy of Sciences, Moscow, Russia

PhD Student

[live\\_love\\_peace@mail.ru](mailto:live_love_peace@mail.ru)

N-heterocyclic carbenes (NHCs) are of ever-growing interest due to their enormous potential as organocatalysts as well as ligands for metal-based catalysts.<sup>1</sup> Strong  $\sigma$ -donicity makes saturated NHCs versatile ligands with the ability to bind not only to d-block transition metals, but also to more electropositive rare-earths. Catalytic properties of NHC-ligated rare-earth complexes are perspective but still underdeveloped due to a mismatch between the hard rare-earth metal center and the relatively soft Lewis base nature of NHCs possibly leading to the dissociation of NHCs in the presence of other Lewis bases (e.g. THF). Polydentate NHC-ligands bearing anionic functions can be designed and successfully employed for the synthesis of metal complexes possessing strong metal-ligand bonds, which, in turn, prevents undesired competition between Lewis bases.

In the present work, bulky N-phenoxy fragments were chosen as substituents on the nitrogen atoms adjacent to the carbene carbon. Rare-earth metal phenoxydes are easily prepared and stable. At the same time, they can serve as suitable pre-catalysts for the polymerization and hydrofunctionalization reactions.

**Figure 1.** Synthesis of scandium halides

A series of NHC pincer pro-ligands was prepared in excellent yield using a general three-step approach. In particular, a new expanded-ring NHC (*er*-NHC) precursor was designed and prepared. The compound has shown diastereotopic behavior in chloroform-*d* solution. Reactions of the compound with the scandium tris(alkyl) Sc(CH<sub>2</sub>SiMe<sub>3</sub>)<sub>3</sub>·THF<sub>2</sub> afforded corresponding scandium halides. It has been shown that a scandium-NHC complex converts into a scandium-coordinated formamide within a short period of time.

Finally, the first example of scandium alkyl bearing pincer-type NHC ligand was obtained. The compound adopts a dimeric structure where each scandium atom is six-coordinate with a slightly distorted octahedral geometry. Synthesized compounds turned out to be active pre-catalysts for the polymerization of isoprene and 1-alkenes and hydrofunctionalization of unsaturated substrates.

### References

[1] Hopkinson M.N., Richter Ch. Schedler M., Glorius F. *Nature* **2014**, *510*, 485–496

Acknowledgements. This work was supported by Russian Foundation for Basic Research (project No 20-33-90191).



# BIOMIMETIC OXIDATION OF WATER BY CERIUM AMMONIUM NITRATE IN THE PRESENCE OF A BINUCLEAR NITRIDE COMPLEX OF RUTHENIUM

*Iliashchenko V. Yu.*<sup>1</sup>, *Dzhabiev T. S.*<sup>2</sup>, *Dzhabieva Z. M.*<sup>2</sup>

<sup>1</sup>M.V. Lomonosov Moscow State University, Russia

<sup>2</sup>Institute of Problems of Chemical Physics, Russian Academy of Sciences, Moscow Region, Chernogolovka, Russia  
[virineya\\_lam@mail.ru](mailto:virineya_lam@mail.ru)

Artificial photosynthesis is one of the effective way to store solar energy (SE), which uses the principles of chemical reactions involved in oxygenic photosynthesis (OFS) for photoinduced water decomposition. In the process of OFS in the oxygen releasing active center of photosystem II, water is oxidized by single-electron oxidizers – cation radicals P680<sup>+</sup> - by reaction:  $4 \text{P680}^{+\bullet} + 2 \text{H}_2\text{O} \rightarrow 4 \text{P680} + \text{O}_2 + 4\text{H}^+$ .

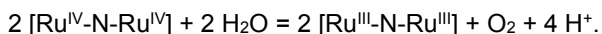
This four-electron concert process is catalyzed by a manganese cofactor  $\text{Mn}_4\text{O}_5\text{Ca}$  the enzyme water: plastoquinone oxidoreductase, which oxidizes water in the OFS. In artificial photosynthesis other transition metals can perform the function of a manganese cofactor: Co, Ni, Fe, Ru, etc. Recently, much attention has been paid to the development of stable high-activity catalysts for the oxidation of water in artificial photosynthesis to create effective converters of SE into the energy of chemical bonds.

Ruthenium complexes with organic ligands show low activity due to the presence of organic ligands that oxidize faster than water and low stability due to the presence of a labile bond Ru-O-Ru.

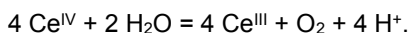
To create an active and stable ruthenium catalyst, the following approaches have been investigated:

- 1) replacing organic ligands in complexes with inorganic ligands;
- 2) replacement of oxygen bridge between ruthenium cores with nitrogen bridge;
- 3) the use of anti-cations in the synthesis of  $\text{Li}^+$ .

In this work, a new inorganic binuclear complex of ruthenium with a nitrogen bridge and  $\text{Li}^+$  anti-cations was synthesized  $\text{Li}_3[\text{Ru}_2(\mu\text{-N})\text{Cl}_8 \cdot 2\text{H}_2\text{O}]$  (**1**). Its structure was studied by the method of PCA, physicochemical and catalytic properties in the reaction of water oxidation in artificial photosynthesis. The bond Ru-N (1.71 Å) is shorter than Ru-O (1.86 Å) in its oxygen analog  $\text{Li}_4[\text{Ru}_2(\mu\text{-O})\text{Cl}_{10} \cdot 2\text{H}_2\text{O}]$ . In dilute aqueous solutions  $\text{Cl}^-$  ions are substituted with  $\text{OH}^-$  and  $\text{H}_2\text{O}$ . In acidic solutions, complex **1** is stable, in the IR-spectra a peak (Ru-N-Ru) is preserved with  $\nu = 1075 \text{ cm}^{-1}$  for several days. Reduction of **1** in 3 M HCl solution occurs in the coordination sphere of the tetra-nuclear cluster  $\text{Ru}_4\text{N}_2\text{O}_5^+$  ( $m/z = 512.28$ ), which catalyzes the four-electron oxidation of water with formation of  $\text{O}_2$ :



Catalytic oxidation of water by a single-electron oxidizer  $(\text{NH}_4)_2\text{Ce}(\text{NO}_3)_6$  also occurs by a four-electron mechanism:



ESI-mass spectrometry analyses of water oxidation reaction products are consistent with kinetic studies. Nitride catalyst activity  $\text{Ru}_4\text{N}_2\text{O}_5^+$  (TOF =  $0.33 \text{ c}^{-1}$ ) ~ is 3 times higher than that of similar oxygen bridged catalyst (TOF =  $0.12 \text{ c}^{-1}$ ). The number of revolutions of the nitride catalyst  $\text{Ru}_4\text{N}_2\text{O}_5^+$  (TON = 360) ~ is an order of magnitude higher than ruthenium complexes containing organic ligands and labile bonds of Ru-O-Ru.

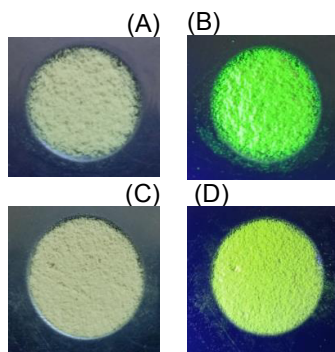
Ivanenko T.Yu.<sup>1</sup>, Golovnev N.N.<sup>1</sup>, Molokeev M.S.<sup>1,2</sup><sup>1</sup>Siberian Federal University, Krasnoyarsk, Russia<sup>2</sup>Laboratory of Crystal Physics, Kirensky Institute of Physics, Federal Research Center KSC SB RAS, Krasnoyarsk, Russia

Student

[timivonk@gmail.com](mailto:timivonk@gmail.com)

OD organic-inorganic halides of  $ns^2$  metal ions ( $Pb^{2+}$ ,  $Sn^{2+}$ ,  $Sb^{3+}$ ) have recently gained attention as highly efficient broadband light emitters [1-3]. In these ionically bonded materials the photoluminescence (PL) are mainly centered at metal halide anions while the role of organic cations consists in the isolation of the  $ns^2$  metal ions. At the same time, the coordination of organic ligands may strongly affect the properties of metallic luminescence centers, leading to high quantum yield photoluminescence (PLQY) and tunable optical properties metal-organic halide complexes.

A new luminescent series  $trans-Pb(DMTU)_4Br_xCl_{2-x}$  ( $DMTU = N,N'$ -dimethylthiourea,  $x = 0, 0.5, 0.61, 1.0, 1.73, \text{ and } 2.0$ ) was obtained by direct grinding of  $PbBr_2$  and  $PbCl_2$  together with  $N,N'$ -dimethylthiourea, as well as by the hydrothermal method. Their absorption, excitation and photoluminescence spectra and thermal stability have been studied. The samples  $trans-Pb(DMTU)_4Br_2$ ,  $trans-Pb(DMTU)_4Cl_2$ ,  $trans-Pb(DMTU)_4BrCl$ ,  $trans-Pb(DMTU)_4Br_{0.5}Cl_{1.5}$ ,  $trans-Pb(DMTU)_4Br_{1.73}Cl_{0.27}$ ,  $Pb(DMTU)_4Br_{0.61}Cl_{1.39}$  under UV-light excitation exhibit a bright broadband green emission with a high PLQY. When heated in air, the compounds first melt without decomposition, and then undergo thermal decomposition at 187-197 °C.



**Figure 1.** The compounds  $Pb(DMTU)_4Cl_2$  and  $Pb(DMTU)_4Br_2$  under day light (A, C) and UV-light excitation 365nm (B, D), respectively

Taking into account the determination error, it can be stated that the replacement of bromide ions with chloride ions in general has a small effect on the quantum yield, the value of which usually lies in the range of 70–90%. The high PLQE of complexes can be explained by the formation of strong hydrogen bonds  $N-H \cdots X$  ( $X = Cl, Br$ ), which impart rigidity to the structure. The broad peak, large Stokes shift and long lifetime of PL suggest that the (PL) of  $trans-Pb(DMTU)_4Br_xCl_{2-x}$  samples should originate from self-trapped exciton (STE)  $^3P_1 \rightarrow ^1S_0$  transition.

### References

- [1] Zhou C.K., Lin H.R. *Chem. Sci.* **2018**, 9(3), 586–593.  
 [2] MacCall K.L., Morad V. *ASC Materials Lett.* **2020**, 2, 1218-1232.  
 [3] Morad V., Shynkarenko Y. *J. Am.Chem.Soc* **2019**, 141(25), 9764–9768.

Acknowledgements. This work was supported by the Russian Foundation for Basic Research (project No 19-52-80003).

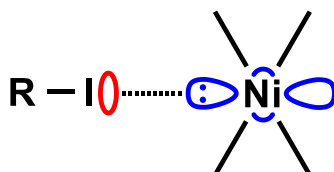
*Ivanov D.M.*<sup>1,2</sup><sup>1</sup> Institute of Chemistry, Saint Petersburg State University, Saint Petersburg 199034, Russia<sup>2</sup> Tomsk Polytechnic University, Tomsk 634034, Russia

Associate Professor

[d.m.ivanov@spbu.ru](mailto:d.m.ivanov@spbu.ru)

Halogen bonding (XB) is actively investigated type of noncovalent interactions, where an electrophilic area on covalently-bound halogen interacts with some nucleophilic center [1]. In most cases, the nucleophilic center is associated with lone pair or  $\pi$ -system on nonmetal atoms. Nonetheless, it was shown  $d^8$  metal centers in square planar complexes can also be nucleophiles due to sterically evaluable lone pairs on  $d_{z^2}$  orbitals, for example, in the formation of the  $C-I\cdots Pd^{II}$  and  $C-I\cdots Pt^{II}$  XBs [2].

In the  $Pt^{II} > Pd^{II} > Ni^{II}$  row the nucleophilicity decreases, and the formation of the  $C-I\cdots Ni^{II}$  XBs is complicated. In this work we show that it is possible in the case of strongly  $\sigma$ -donating ligands, which increase the energy of  $d_{z^2}$  orbitals. The  $C-I\cdots Ni^{II}$  XBs (**Figure 1**) was achieved in the cocrystallization of *sym*-triiodotrifluorobenzene taken as I-centered electrophile with nickel(II) nitrosoguanidinate *trans*-[Ni(NH=C(NMe<sub>2</sub>)NN(O))<sub>2</sub>] [3] and nickel(II) dithiocarbamate [Ni(Et<sub>2</sub>NCS<sub>2</sub>)<sub>2</sub>] [4]. The formation of the  $C-I\cdots Ni^{II}$  interactions was detected by single-crystal X-ray diffraction experiments and confirmed by following density functional theory calculations.



**Figure 1.** The  $C-I\cdots Ni^{II}$  XBs.

#### References

- [1] G. R. Desiraju, P. S. Ho, L. Kloo, A. C. Legon, R. Marquardt, P. Metrangolo, P. Politzer, G. Resnati, K. Rissanen. *Pure Appl. Chem.* **2013**, *85*, 1711–1713.
- [2] S.V. Baykov, U. Dabranskaya, D.M. Ivanov, A.S. Novikov, V.P. Boyarskiy. *Cryst. Growth Des.* **2018**, *18*, 5973–5980.
- [3] Z.M. Bikbaeva, D.M. Ivanov, A.S. Novikov, I.V. Ananyev, N.A. Bokach, V.Yu. Kukushkin. *Inorg. Chem.* **2017**, *56*, 13562–13578.
- [4] L.E. Zelenkov, A.A. Eliseeva, S.V. Baykov, V.V. Suslonov, B. Galmés, A. Frontera, V.Y. Kukushkin, D.M. Ivanov, Bokach N.A. *Inorg. Chem. Front.* **2021**, *8*, 2505–2517.

Acknowledgements. Physicochemical studies were performed at the Centre for X-ray Diffraction Studies (belonging to Saint Petersburg State University).

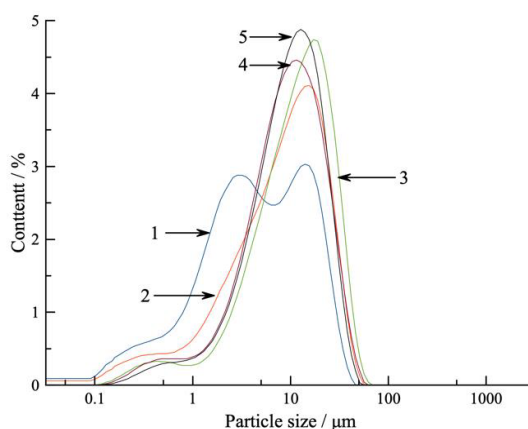
CO-PRECIPITATION OF STRONTIUM AND BARIUM PHOSPHATES WITH LANTHANIDES  
FROM ALKALI CHLORIDE BASED MELTS

*Ivanov A.B.*<sup>1</sup>, *Homutinina D.A.*<sup>1</sup>, *Volkovich V.A.*<sup>1</sup>, *Pavlova E.A.*<sup>1</sup>, *Chukin A.V.*<sup>1</sup>, *Malychev A.S.*<sup>1</sup>

<sup>1</sup> Ural Federal University, Yekaterinburg, Russia  
Young Scientist  
[chivasch@yandex.ru](mailto:chivasch@yandex.ru)

Earlier [1–3], the effect of an excess of phosphate ions on the degree of precipitation of barium and lanthanide phosphates, as well as on the phase composition and particle size of the resulting phosphates, was studied. In this work, the effect of lanthanide chlorides present in the melt on the precipitation of barium and strontium phosphates was determined.

To determine the conditions required for complete removal of barium, the initial phosphate-to-barium molar ratio in the melt was set at 0.5; 1.2; 1.8; 2.4 and 3.5. The residual barium content in the melt was determined by the mass spectroscopy. Precipitated phosphates were subjected to X-ray powder diffraction analysis. Particle size was determined by laser diffraction and examples of particle size distribution curves for precipitates formed in (Na-K)Cl+LaCl<sub>3</sub>+BaCl<sub>2</sub> based melts are shown in Fig. 1. The precipitates consisted of particles ranging from 0.1 to 100 microns. Increasing the initial (Ba/La):PO<sub>4</sub><sup>3-</sup> ratio resulted in increasing particle size. The results of the X-ray powder diffraction analysis of phosphates are presented in Table 1.



**Figure 1.** Particle size distribution curves for barium phosphate precipitated from (Na-K)Cl+LaCl<sub>3</sub>+BaCl<sub>2</sub> based melts at 1023 K. Initial (Ba/La):PO<sub>4</sub><sup>3-</sup> ratio was 0.5 (line 1); 1.2 (2); 1.8 (3); 2.4. (4); 3.5 (5).

**Table 1.** Precipitation of strontium and barium phosphates from alkali chloride based melts.

(Ba/La):PO <sub>4</sub> <sup>3-</sup> ratio	Solid Phase Composition
0.5	Ba <sub>4</sub> La <sub>2</sub> O <sub>7</sub> , LaPO <sub>4</sub>
1.2	Na <sub>2</sub> Ba <sub>6</sub> La <sub>2</sub> (PO <sub>4</sub> ) <sub>6</sub> Cl <sub>2</sub> , LaPO <sub>4</sub> , La <sub>3</sub> PO <sub>7</sub>
1.8	Na <sub>2</sub> Ba <sub>6</sub> La <sub>2</sub> (PO <sub>4</sub> ) <sub>6</sub> Cl <sub>2</sub> , LaPO <sub>4</sub> , Na <sub>3</sub> Ce(PO <sub>4</sub> ) <sub>2</sub> , La <sub>3</sub> PO <sub>7</sub> , La <sub>2</sub> O <sub>3</sub>
2.4	Na <sub>2</sub> Ba <sub>6</sub> La <sub>2</sub> (PO <sub>4</sub> ) <sub>6</sub> Cl <sub>2</sub> , LaPO <sub>4</sub> , La <sub>3</sub> PO <sub>7</sub> , La <sub>2</sub> O <sub>4</sub> , Na <sub>4</sub> P <sub>2</sub> O <sub>7</sub> , NaBaPO <sub>4</sub>
3.5	NaBaPO <sub>4</sub> , Na <sub>4</sub> P <sub>2</sub> O <sub>7</sub>

#### References

- [1] A. B. Ivanov, E. D. Byzova, V. A. Volkovich, A. V. Chukin, and T. R. Griffiths, *ECS Transactions*, **2020**, 98(10), 283-294.  
 [2] A. B. Ivanov, V. V. Sukhikh, V. A. Volkovich, B. D. Vasin, A. V. Chukin, *Russian Metallurgy*, **2019**, (2), 152-154.  
 [3] V. V. Sukhikh, A. B. Ivanov, V. A. Volkovich, B. D. Vasin, A. V. Chukin and T. R. Griffiths, *AIP Conference Proceedings*, **2018**, 2015, 020099 (1-6).

Acknowledgements. This work was supported by by the Council for Grants of the President of the Russian Federation SP-2021.

# MIXED-METAL FORMATRIAZOLE DICARBOXYLATES OF SAMARIUM, GADOLINIUM AND TERBIUM: SYNTHESIS, STRUCTURE, AND LUMINESCENT PROPERTIES

*Ivanova A.A.*<sup>1</sup>, *Belousov Yu.A.*<sup>1</sup>, *Lunev A.M.*<sup>1</sup>

<sup>1</sup>M.V. Lomonosov Moscow State University, Moscow, Russia

Student

[rusitur2@gmail.com](mailto:rusitur2@gmail.com)

The luminescence of lanthanide complexes with organic ligands is widely studied in connection with their use as luminescent thermometers, OLEDs, sensor materials, and for the protection of banknotes and securities. Most of the works of lanthanide complexes with organic ligands are devoted to  $\beta$ -diketonates and aromatic carboxylates of rare earth elements (REE). The complexes of lanthanides with heterocyclic carboxylic acids is significantly less studied. At the same time, these compounds have good absorption properties and photo- and thermal stability. To create a well-luminescent lanthanides complexes, it is necessary to minimize the number of OH<sup>-</sup>, CH- and NH-bonds in the complex molecules, which contribute to the effective quenching of the luminescence of REE ions. Deprotonated ion TDA<sup>3-</sup> does not contain CH-, NH- and OH-groups that cause luminescence quenching.

Previously, the structure of europium and gadolinium triazoldicarboxylates in our laboratory was described [1], where, thanks to the replacement of the solvent with a DMF-water mixture, it was possible to remove intra-sphere water molecules that cause vibrational quenching of Eu<sup>3+</sup> luminescence.

In this work, the optimal conditions for the production of crystals  $\{(NMe_2H_2)\}[Sm(TDA)(HCOO)] \cdot nH_2O$  were described. It was shown that the pH of the solution should be 1.5, and the optimal synthesis temperature is 160 °C. The crystal structure of this compound was described by X-ray diffraction. Two series of complexes of mixed metals samarium-gadolinium and samarium-terbium with 1,2,3-triazole-4,5-dicarboxylic acid:  $\{(NMe_2H_2)(Sm_{1-x}Gd_x)(TDA)(HCOO)\}$ ;  $\{(NMe_2H_2)(Sm_{1-x}Tb_x)(TDA)(HCOO)\}$  were synthesized and characterized.

The luminescence spectra of the excitation and emission of these compounds were recorded. In the luminescence spectra of the Sm-Gd series, Sm<sup>3+</sup> ion transition bands and ligand phosphorescence bands were observed, while for the Sm-Tb series, the Sm<sup>3+</sup> and Tb<sup>3+</sup> bands were observed together. The single-phase and isostructural properties of the compounds were confirmed by X-ray diffraction.

## References

[1] Belousov Yu.A., Goncharenko V.E., Lunev A.M., Sidoruk A.V., Bezzubov S.I., Taydakov I.V. *Coordination Chemistry* **2020**, 46, 1-8

# SYNTHESIS AND INVESTIGATION OF PHOTOLUMINESCENT COMPLEXES OF RARE EARTH METALS WITH 1-(1H-BENZIMIDAZOL-1YL-METHYL)-1H-BENZOTRIAZOLE

Ivanova E.A.<sup>1,2</sup>, Smirnova K.S.<sup>1</sup>

<sup>1</sup>Nikolaev Institute of Inorganic Chemistry, SB RAS, Novosibirsk, Russia

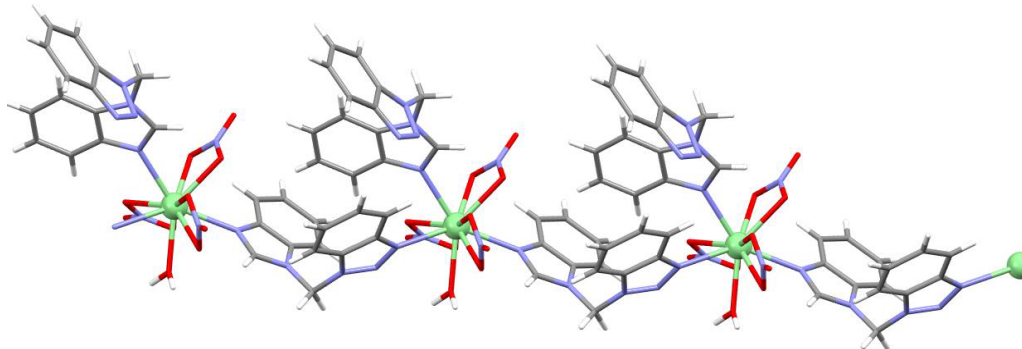
<sup>2</sup>Novosibirsk State University, Russia

Student

[e.ivanova4@q.nsu.ru](mailto:e.ivanova4@q.nsu.ru)

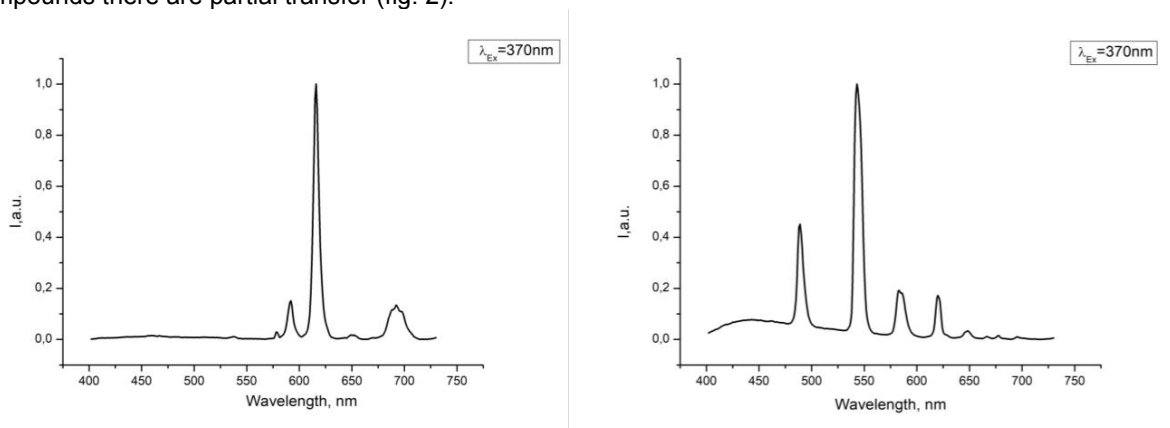
The preparation of complex compounds with benzotriazole derivatives is a promising direction due to their wide application in pharmacology and medicine as drugs, since these compounds exhibit of biological activity. Studies show that due to the structure of benzotriazole derivatives and the presence of several nitrogen atoms, it is possible to obtain a variety of structures. In addition, some complex compounds with benzimidazole derivatives have luminescent properties, but they are poorly studied.

In this work, a number of complex compounds of rare earth metals (Eu(III), Tb(III), Sm(III), Dy(III), Gd(III)) with 1-(1H-benzimidazol-1yl-methyl)-1H-benzotriazole (L) was synthesized. The complexes have been characterized by elemental and powder X-ray diffraction analysis, and IR spectroscopy. The crystal structures of some complexes have been determined by single-crystal X-ray diffraction analysis. In the compound  $[\text{Tb}(\text{L})_2(\text{H}_2\text{O})(\text{NO}_3)_3]_n$  one ligand molecule is coordinated in a bidentate-bridging mode by the nitrogen atoms of the triazole and imidazole rings to form a polymer chain. The second ligand is coordinated monodentately by the nitrogen atom of the imidazole ring. The coordination sphere of the metal ion is supplemented by six oxygen atoms of three nitrate ions and one oxygen atom of a water molecule, thus the coordination number of the central atom is 10 (fig. 1).



**Figure 1.** Structure of the polymeric chain in the complex  $[\text{Tb}(\text{L})_2(\text{H}_2\text{O})(\text{NO}_3)_3]_n$ .

The excitation and emission spectra, lifetimes of the excited states, and quantum yields of the ligand and obtained complexes have been investigated. In emission spectra of lanthanide compounds complete or partial energy transfer from the ligand to the emission level of the metal is observed. In the case of the europium(III) complex a complete energy transfer occurs, and in the samarium(III), terbium(III), and dysprosium(III) compounds there are partial transfer (fig. 2).



**Figure 2.** Emission spectrum of the complexes  $[\text{Eu}(\text{L})_2(\text{H}_2\text{O})(\text{NO}_3)_3]_n$  and  $[\text{Tb}(\text{L})_2(\text{H}_2\text{O})(\text{NO}_3)_3]_n$ .

Acknowledgements. This work was supported by the Russian Science Foundation (project № 20-73-10207).

# STUDY OF THE ELECTROCHEMICAL PROPERTIES OF NICKEL COMPLEXES BASED ON BIDENTATE NITROGEN-CONTAINING LIGANDS

Kagilev A.A.<sup>1,2</sup>, Soficheva O.S.<sup>1</sup>, Kagileva A.A.<sup>1,2</sup>, Gafurov Z.N.<sup>1</sup>, Morozov V.I.<sup>1</sup>,  
Zueva E.M.<sup>2,3</sup>, Mamedov V.A.<sup>2</sup>, Yakhvarov D.G.<sup>1,2</sup>

<sup>1</sup>Arbuzov Institute of Organic and Physical Chemistry, FRC Kazan Scientific Center, Kazan, Russia

<sup>2</sup>Kazan Federal University, Alexander Butlerov Institute of Chemistry, Kazan, Russia

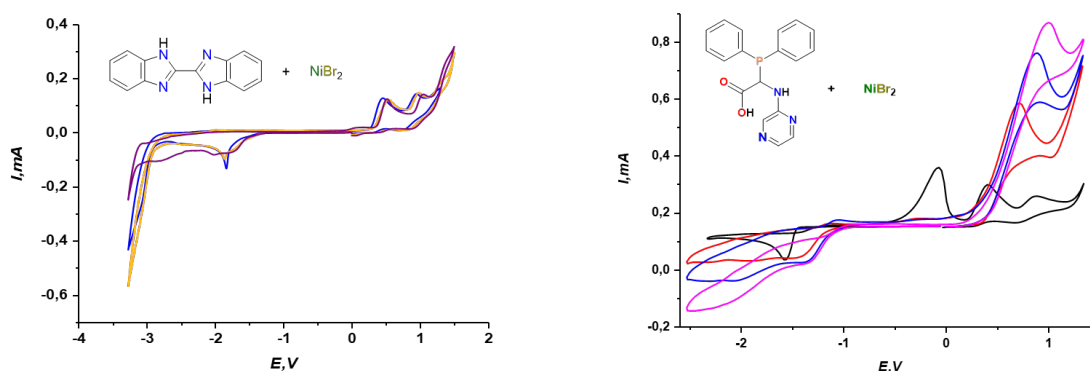
<sup>3</sup>Kazan National Research Technological University, Kazan, Russia

PhD Student

[al-kagilev@mail.ru](mailto:al-kagilev@mail.ru)

Nickel complexes based on nitrogen-containing ligands have deserved increasing attention as versatile catalysts for a wide range of organic transformations, including ethylene oligomerization and polymerization. Variation on the ligand nature at the nickel center leads to fine tuning of homogeneous ethylene oligomerization products. However, the generation of catalytically active nickel complexes with nitrogen-containing ligands are traditionally based on the use of flammable and toxic precursors [1,2]. Encouraged by the principles of "green chemistry", we are developing an alternative new electrochemical approach for obtaining organonickel catalysts, based on  $\alpha$ -diphenylphosphinoglycines and 2,2'-bibenzimidazoles. The use of the electron as an "universal" and "inexhaustible" reagent is the main advantage of the electrochemical techniques applied for preparation of chemical compounds of different classes.

Thus, this work represents the electrochemical properties of the ligands ( $\alpha$ -diphenylphosphinoglycines and 2,2'-bibenzimidazoles) themselves and the bidentate nickel complexes based on them (Figure 1).



**Figure 1.** Cyclic voltammetry of ligand (2,2'-bibenzimidazole and  $\alpha$ -diphenylphosphinoglycine) in the presence of increasing amounts of nickel dibromide

The electrochemical reduction of 2,2' bibenzimidazoles allows obtaining their deprotonated form, suitable for complexation with nickel precursor, which open up new possibilities in coordination chemistry. In the case of the  $\alpha$ -diphenylphosphinoglycine ligand at a potential of -2.2 V, the formation of a new reduction peak was observed when the amount of nickel salt was increased, indicating the formation of a new complex based on the  $\alpha$ -diphenylphosphinoglycine ligand, which is in agreement with literature data for similar systems [3].

## References

- [1] Fomina O.S., Ph.D. thesis, Kazan, **2017**
- [2] Keim W. *Vysokomol. Soedin.* **1994**, *36*, 1644
- [3] Fomina O.S., Kislitsyn Yu. A., Babaev V.M., Rizvanov I.Kh., Sinyashin O.G., Heinike I., Yakhvarov D.G., *Russ. J. Electrochem.* **2015**, *51*, 1206.

Acknowledgements. This work was supported by Russian Foundation for Basic Research (project No 19-29-08051).

*Kaimonov M.R.<sup>1</sup>, Safronova T.V.<sup>1</sup>, Tikhomirova I.N.<sup>2</sup>, Shatalova T.B.<sup>1</sup>*<sup>1</sup>Lomonosov Moscow State University, Moscow, Russia<sup>2</sup>Mendeleev University of Chemical Technology, Moscow, Russia

PhD student

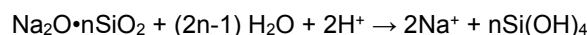
[M.R.Kaimonov@yandex.ru](mailto:M.R.Kaimonov@yandex.ru)

The creation of artificial bone tissue substitutes is still a challenge for medical inorganic materials science. The field of bioinductive materials has received abundant development since such materials can bind to both bone tissue and soft tissue after surgical operations. In that field, bioinductive materials generally based on amorphous or crystalline phases of the Na<sub>2</sub>O–CaO–SiO<sub>2</sub>–P<sub>2</sub>O<sub>5</sub> system are more preferred. Known methods for obtaining materials in this system, included melting and glass homogenization or using a sol-gel technique, are economically costly and multi-stage. An aqueous solution of sodium silicate Na<sub>2</sub>O·nSiO<sub>2</sub> which could be used as a binder of biocompatible ceramic materials based on powders of synthetic calcium phosphates (CP) in the Na<sub>2</sub>O–CaO–SiO<sub>2</sub>–P<sub>2</sub>O<sub>5</sub> system allows to eliminate these disadvantages.

This work aimed to obtain a biocompatible ceramic material based on synthetic calcium phosphates and the aqueous solution of sodium silicate with a given phase composition in the Na<sub>2</sub>O–CaO–SiO<sub>2</sub>–P<sub>2</sub>O<sub>5</sub> system intended for use in medicine.

In the research, highly concentrated suspensions consisting of dispersion medium and dispersed phase were prepared. Synthetic calcium phosphate powders (hydroxyapatite, tricalcium phosphate and pyrophosphate) were used as a dispersed phase. The aqueous sodium silicate solution with the silica module (SiO<sub>2</sub>/Na<sub>2</sub>O) = 2,87 was used as a dispersion medium. The composition of the initial powder mixture was adjusted by adding calcium oxide CaO and sodium carbonate Na<sub>2</sub>CO<sub>3</sub>.

Pre-ceramic semi-finished products in the form of blocks were obtained by moulding in silicone moulds, and simple 3-dimensional layered geometric shapes were obtained by extrusion moulding using a syringe. The samples hardening occurred spontaneously both due to polycondensation of an aqueous sodium silicate solution and because of air-drying:



Ceramic materials after firing at 1000°C consisted of sodium-calcium silicate Na<sub>6</sub>Ca<sub>3</sub>Si<sub>6</sub>O<sub>18</sub> and β-rhenanite β-NaCaPO<sub>4</sub>. The geometric density of materials for all samples after firing at 1000°C was 0.76 – 0.78 g/cm<sup>3</sup>, and the compressive strength was 2.5 – 3.5 MPa.

To sum it up, the highly concentrated suspensions based on synthetic calcium phosphates and the aqueous sodium silicate solution can be recommended for porous composite biomaterials preparation with both defined geometry and a porous architecture of implants using extrusion 3D printing. The approach proposed in the current work allows one to achieve a given phase composition of composite biocompatible ceramic materials in the Na<sub>2</sub>O–CaO–SiO<sub>2</sub>–P<sub>2</sub>O<sub>5</sub> system.

Acknowledgements. This work was supported by the Russian Foundation for Basic Research (project No 18-29-11079).



COBALT(II/III) TRIS-PHENANTHROLINES WITH DIFFERENT POLYIODIDE ANIONS:  
SYNTHESIS AND STRUCTURE

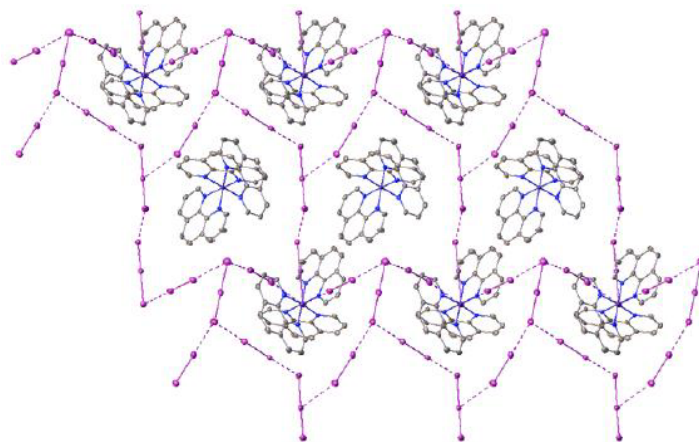
*Kalle P.<sup>1</sup>, Bezzubov S.I.<sup>1</sup>*

<sup>1</sup>Kurnakov Institute of General and Inorganic Chemistry, Moscow, Russia

Student

[kalle@igic.ras.ru](mailto:kalle@igic.ras.ru)

Cobalt (II) tris-phenanthroline perchlorate and similar salts with polyiodide anions were synthesized and structurally characterized. In crystals, complex cations are packed through numerous C–H⋯ $\pi$  and  $\pi$ ⋯ $\pi$  contacts, while iodine-containing anions are isolated and interact with the  $\pi$ -system of aromatic ligands. Spontaneous oxidation of cobalt (II) tris-phenanthroline with iodine leads to a crystalline product containing a triply charged complex cation, triiodide anions, and molecular iodine. In the crystal, the anions and iodine molecules form a framework of iodine atoms by halogen-halogen interactions, while complex cations are held in this framework by C – H ⋯ I and I ⋯  $\pi$  contacts and are not directly interact with each other. The study gives some insights into the nature of interactions that can occur when dye-sensitized solar cells containing tandem iodine and cobalt redox mediators operate.



Acknowledgements. This work was supported by the Russian Science Foundation (project No 19-73-00351).

NEW SUSTAINABLE ELECTROCHEMICAL METHODS FOR GENERATION OF CATALYTICALLY ACTIVE SYSTEMS BASED ON GROUP VIII METALS FOR ETHYLENE OLIGOMERIZATION

*Kantuykov A.O.*<sup>1,2</sup>, *Gafurov Z.N.*<sup>1</sup>, *Soficheva O.S.*<sup>1</sup>, *Yakhvarov D.G.*<sup>1,2</sup>

<sup>1</sup>Arbuzov Institute of Organic and Physical Chemistry, FRC Kazan Scientific Center, Russian Academy of Sciences, Kazan, Russia

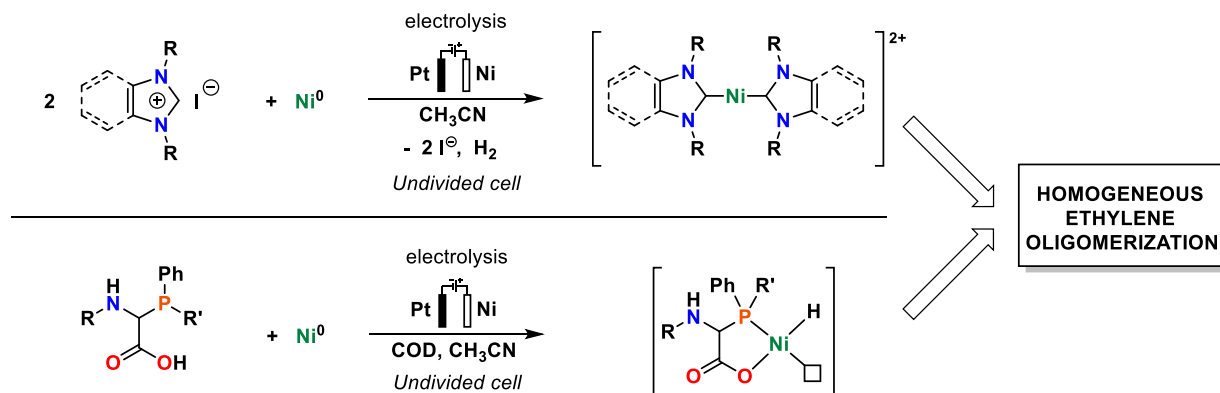
<sup>2</sup>Kazan Federal University, A.M. Butlerov Institute of Chemistry, Kazan, Russia

Student

[kant.art@mail.ru](mailto:kant.art@mail.ru)

One of the main tasks of modern transition metal chemistry is the development of new powerful and environmentally friendly methods for producing of new highly efficient low-cost homogeneous catalyst systems based on complexes of group VIII 3d-metals (iron, cobalt, nickel) for the processes of oligomerization and polymerization of ethylene using the electrochemical techniques with combination of coordination chemistry principles [1].

This study aims to optimize the conditions of sustainable electrochemical generation of complexes of nickel and other group VIII 3d-metals for application as homogeneous catalytic systems for ethylene oligomerization process [2,3]. Figure 1 represents the scheme of the electrochemical synthesis of *N*-heterocyclic carbene complexes of nickel based on imidazolium and benzimidazolium salts and  $\alpha$ -phosphino- $\alpha$ -amino acid derivatives [4]. The synthesis takes place at room temperature and does not require the supporting electrolyte (since imidazolium salts and  $\alpha$ -phosphinoglycine derivatives are an excellent conducting material). Electrochemical approach represents the direct and highly reliable method for obtaining organometallic compounds starting from metal plate and Imidazole derivatives or *N*- and *P*- substituted  $\alpha$ -phosphinoglycine systems, while classical methods involve multiple reaction stages and additional reagents. Moreover, the use of the electron as an “universal” and “inexhaustible” reagent is the main advantage of the electrochemical techniques applied for preparation of chemical compounds of different classes [5].



**Figure 1.** New sustainable electrochemical methods for generation of catalytically active systems based on group VIII metals for ethylene oligomerization

### References

- [1] Gafurov Z.N., Kantuykov A.O., Kagilev A.A., Balabayev A.A., Sinyashin O.G., Yakhvarov D.G. *Russ. Chem. Bull.* **2017**, *66*, 1529–1535
- [2] Ren X., Wesolek M., Bailly C., Karmazin L., Braunstein P. *Eur. J. Inorg. Chem.* **2020**, *2020*, 1073-1087
- [3] Hameury S., Fremont P., Breuil PAR., Olivier-Bourbigou H., Braunstein P. *Organometallics* **2015**, *34*, 2183-2201
- [4] Soficheva O.S., Bekmukhamedov G.E., Dobrynin A.B., Heinicke J.W., Sinyashin O.G., Yakhvarov D.G. *Mendeleev Commun.* **2019**, *29*, 575–577
- [5] Gafurov Z.N., Kantuykov A.O., Kagilev A.A., Sinyashin O.G., Yakhvarov D.G. *Coord. Chem. Rev.* **2021**, *442*, 213986

Acknowledgements. This work was supported by Russian Foundation for Basic Research (project No 19-29-08051).

# STRUCTURE, DIFFUSION AND SELF-DIFFUSION COEFFICIENTS OF PROTON SUBSTITUTED $\beta$ -ALUMINA

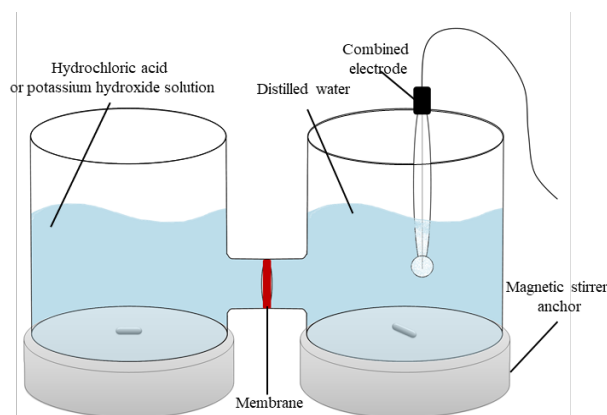
*Kaplanova V.I.<sup>1</sup>, Kurapova O.Yu.<sup>1</sup>*

<sup>1</sup>Saint Petersburg State University, Saint Petersburg, Russia

Student

[3vit\\_toria@mail.ru](mailto:3vit_toria@mail.ru)

Nowadays the development and the implementation of green energy sources is becoming extremely important. Here,  $H\text{-}\beta\text{-Al}_2\text{O}_3$  is regarded as an attractive material for the use as a proton conducting solid electrolyte (SE) in low-temperature fuel cells. Thus, the aim of this work was to study the phase composition, structure, and transport properties of  $H\text{-}\beta\text{-Al}_2\text{O}_3$  ceramics. Precursor of  $\text{Na}_2\text{O}\cdot 6.5\text{Al}_2\text{O}_3$  composition was manufactured via pyrolysis, compacted into the membranes ( $h=5\text{mm}$ ,  $d=30\text{mm}$ ) at pressure  $10\text{ tons/cm}^2$  and annealed at  $1520\text{ }^\circ\text{C}$  for 2 hours.  $H\text{-}\beta\text{-Al}_2\text{O}_3$  SE was obtained by ion exchange technique of  $\text{Na}\text{-}\beta\text{-Al}_2\text{O}_3$  membrane in  $\text{HNO}_3$  and  $\text{H}_2\text{O}$  at room temperature. Ion exchange was controlled in water using conductometry (inoLab Cond7110) and in acid using atomic emission spectroscopy (ICPE-9000). The degree of substitution of  $\text{Na}^+$  for  $\text{H}^+$  in an acidic medium was calculated. Structure of  $H\text{-}\beta\text{-Al}_2\text{O}_3$  SE was examined by XRD (SHIMADZU XRD-6000), hydrostatic weighing (RADWAG WAS 220/X), SEM and EDX techniques (Hitachi S-3400N). The transport properties of SE were investigated using EMF method in the cell shown in Fig. 1 at three different initial concentrations of hydrochloric acid and potassium hydroxide (0.1, 0.2, and 0.4 N).



**Figure 1.** Installation diagram for the experiment.

The  $\text{Na}^+$  to  $\text{H}^+$  exchange results in the peaks intensity enhancement in the XRD pattern without shifting their positions. The resulting diagram corresponds to the protonated  $\beta$ -alumina phase. Via SEM and EDX it was found that both  $\beta$ - and  $\beta''$ -alumina are present in the SE structure.  $\text{Na}^+$  is exchanged by a  $\text{H}^+$  in the  $\beta$ -alumina phase only, no substitution occurs in sodium  $\beta''$ -alumina phase. The density was measured by hydrostatic weighing before and after the exchange. Diffusion and self-diffusion coefficients were calculated from the EMF data for the proton and potassium cation. The values obtained correlate well with the literature [1]. It was suggested that proton transport is carried out through the  $H\text{-}\beta$ -alumina and  $\text{Cl}^-$  transport takes place through sodium  $\beta''$ -alumina.

## References

[1] Yao Y. F. Y., Kummer J. T. *J. Inorg. Nuclear Chem.* **1967**, 29, 2453–2475.

Acknowledgements. SEM and EDX data were obtained at «GEOMODEL» center, AES measurement was performed at «Center for Chemical Analysis and Materials Research» and XRD data was obtained at «Research Centre for X-ray Diffraction Studies» at SPBU Research park.

*Kapustin R.V.<sup>1</sup>, Vorotyntsev A.V.<sup>1</sup>, Petukhov A.N.<sup>1</sup>*

<sup>1</sup>Nizhny Novgorod State Technical University, Nizhny Novgorod, Russia

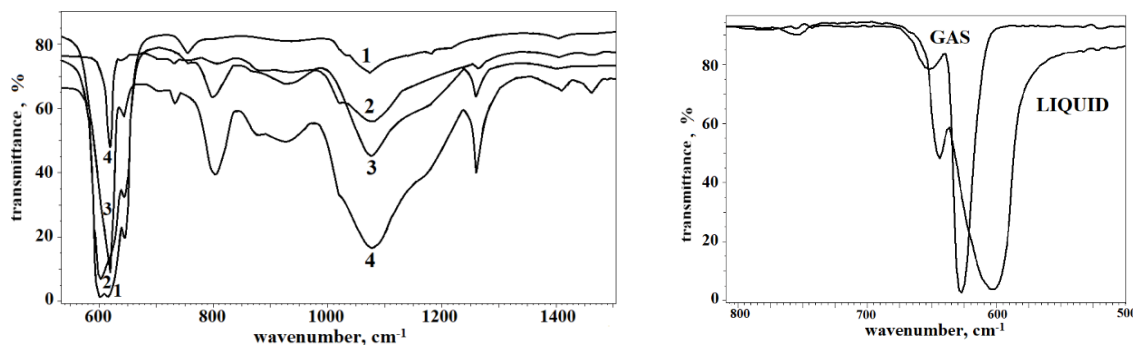
PhD Student

[kapustin-nttu@mail.ru](mailto:kapustin-nttu@mail.ru)

Chlorosilanes have an important practical application, in first regard, as sources for semiconductor materials of different types [1]. The silane oxide films play a crucial role in the production of these systems. The direct reactions of chlorosilanes oxidation at ambient conditions is a poorly controlled process that does not lead to the formation of a homogeneous film. Besides, such an oxidation leads to the hydrolysis of the sample, because it is difficult to dry the oxidation gas completely [2]. Nevertheless, it was showed that in the near-surface area thin layers of various molecular structures, having properties that are not available at standard conditions, can arise [3]. In this work the oxidation process of tetra-, tri-, di-chlorosilanes by atmospheric air in combination with the thin layer generation and *in-situ* IR study was carried out.

For generation of thin layers combined with the IR spectral control of this process *in-situ*, the following procedure conducted in the argon box was used. The sample was placed under a Teflon gasket (1 mm thick) on a KBr optical window to prevent falling into the optical beam. Then the gasket was covered by another window, and both windows were placed in the holder for spectra recording. Spectral measurements were carried out for a certain time, during which the sample was left between the windows in the open air at ambient conditions. The spectra recording was repeated every day for a month.

In Fig.1 the dynamic of spectra changing in time for SiCl<sub>4</sub> (left side) in comparison with its liquid and gas spectra (right side) is shown. The spectrum 1 was recorded in 10 minutes, spectrum 2 – 7 days, spectrum 3 – 21 days, and spectrum 4 – one month after sample preparing. The main results of experiments confirm that chlorosilanes, which are very sensitive to oxygen and water vapor action, remain intact in the generated system for a long time, although the layer composition changes. In spectrum 1 the bands of liquid (at 603 cm<sup>-1</sup>) and gas state (at 620 cm<sup>-1</sup>) of SiCl<sub>4</sub> are observed. In spectra 2-4 the intensity of gaseous band in series decreases and disappears in spectrum 4. At the same time, the intensity of silicon oxide bands at 1075 and 803 cm<sup>-1</sup> grows. The bands, assigning to O-H stretching vibrations, which can appear owing to hydrolysis, were not detected at all.



**Figure 1.** Spectra fragments of SiCl<sub>4</sub> in Si-Cl stretching region

The IR spectra of tri- and di-chlorosilanes recorded in time show similar features. The initial silanes are encapsulated in the silicon oxide film, forming on the optical window, and their spectra remain with minor changes for a long time. The bands of O-H bond vibrations are absent in all recorded in time spectra. The band intensities, assigning to silicon oxide film, grow while the ones belonging to silanes decrease. It means that the oxide film is sufficiently flexible for oxygen penetration, but the hydrolysis of silanes does not occur.

Thus, it can be resumed that at silanes oxidation-hydrolysis process in the generated thin layers with the atmospheric oxygen and water vapor forms a silicon oxide film that contains encapsulated silanes, and this film protects substances from further destruction of initial structure.

#### References

- [1] Vorotyntsev A.V., Markov A.N. *Phosphorus, Sulfur Silicon Relat. Elem.* **2021**, 196, 176
- [2] Xiao Y., Wang Y., Luo G., Bai S. *Chem. Eng. J.* **2016**, 283, 1
- [3] Eremin D.B., Ananikov V.P. *Coord. Chem. Rev.* **2017**, 346, 2

Acknowledgements. This work was supported by Ministry of Science and Higher Education of Russian Federation in the Framework of the State Task Basic Part (FSWE-2020-0008, project No 0728-2020-0008).

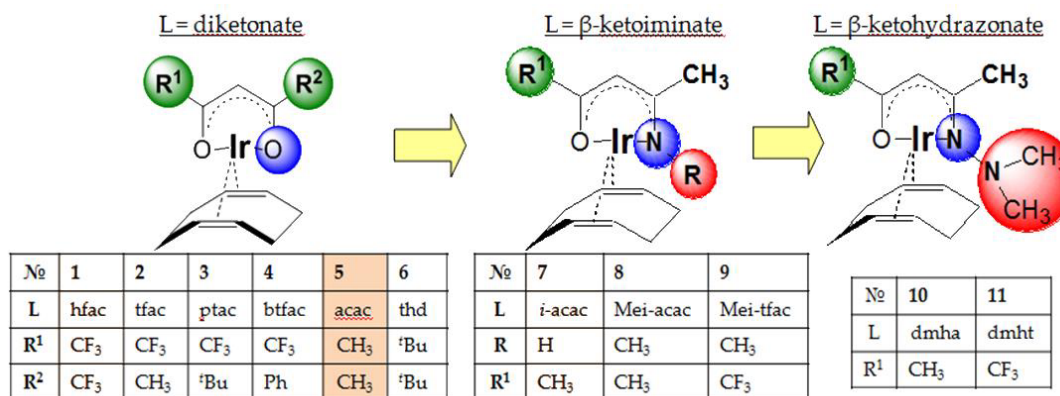
IRIDIUM COATINGS FOR METAL MEDICAL IMPLANTS OBTAINED BY MOCVD:  
FROM VOLATILE PRECURSORS TO BIOCOMPATIBILITY TEST

*Karakovskaya K.I.<sup>1</sup>, Vikulova E.S.<sup>1</sup>, Chepeleva E.V.<sup>2</sup>*

<sup>1</sup> Nikolaev Institute of Inorganic Chemistry, Novosibirsk, Russia  
<sup>2</sup> Meshalkin National Medical Research Center, Novosibirsk, Russia  
PhD student  
[red\\_garden@mail.ru](mailto:red_garden@mail.ru)

Nowadays, titanium-based alloys are the most widely used materials for the manufacturing of implants and other devices for orthopedics and reconstructive surgery. Nevertheless, a special surface functionalization is required here to improve biocompatibility and impart antibacterial properties. This can be achieved simultaneously by using film heterostructures based on Ir and Ag/Au, which have improved biocide effect [1] and high corrosion resistance in biological media. For this purpose, we propose metal-organic chemical vapor deposition (MOCVD) as a precision method that allows obtaining coatings on complex shapes objects.

This work was focused on obtaining of metal Ir coatings on Ti alloy (VT-6) and TiNi substrates by MOCVD. Recently, the hetero-ligand Ir(I) complexes with beta-diketonate derivatives have been declared as suitable volatile precursors, but they are not sufficiently investigated [2]. Herein, we presented a series of complexes [Ir(cod)(L)] (cod = cyclooctadiene-1,5, L = different anionic ligands) to study the impact of the terminal substituents and metal coordination environment on the thermal properties of the precursor (Fig. 1).



**Figure 1.** Hetero-ligand complexes [Ir(cod)(L)], studied in this work.

The complexes were synthesized in inert atmosphere with approximately 80% yields. Complexes **3** and **4**, **7-11** were obtained for the first time. The compounds were characterized by elemental analysis, IR and <sup>1</sup>H and <sup>13</sup>C NMR, and powder XRD. The thermal properties of complexes were investigated by differential scanning calorimetry, thermogravimetry and tensiometry. The sublimation thermodynamic parameters were calculated. The volatility row of the complexes is following: L = **1** > **2** > **3** > **4** > **5** > **9** > **6** > **7** > **8** > **4**.

Compound **5** was selected for more detailed investigation and coating preparation. The suitable MOCVD parameters were determined based on tensiometry and *in situ* mass-spectrometry data. To obtain the coatings with developed morphology, oxygen was applied as a reagent gas. The effects of the deposition temperature (290–350 °C) and amount of introduced oxygen (2-8 l·h<sup>-1</sup>) on the composition (Ir, Ir + IrO<sub>2</sub>) and microstructure of the samples were studied. It allowed obtaining Ir coatings by MOCVD on Ti-based alloys for the first time. To assess the biocompatibility, the toxicity of the Ir/Ti, Ir/TiNi samples to human fibroblast cells was examined in dynamics. The results obtained were explained based on the coating microstructures.

### References

- [1] Köller, M.; Bellona, P.; Javid, S.M.; Motemani, Y.; Khare, C. *Mater. Sci. Eng. C* **2016**, *74*, 536–541  
[2] Karakovskaya, K.I.; Dorovskikh, S.I.; Vikulova, E.S.; Ilyin, I.Y. *Coatings* **2021**, *11*, 78

Acknowledgements. Study of iridium precursors and coatings on Ti alloy was supported by RSF (research project № 20-15-00222).

*Kashnik I.V.<sup>1</sup>, Brylev K.A.<sup>1</sup>*

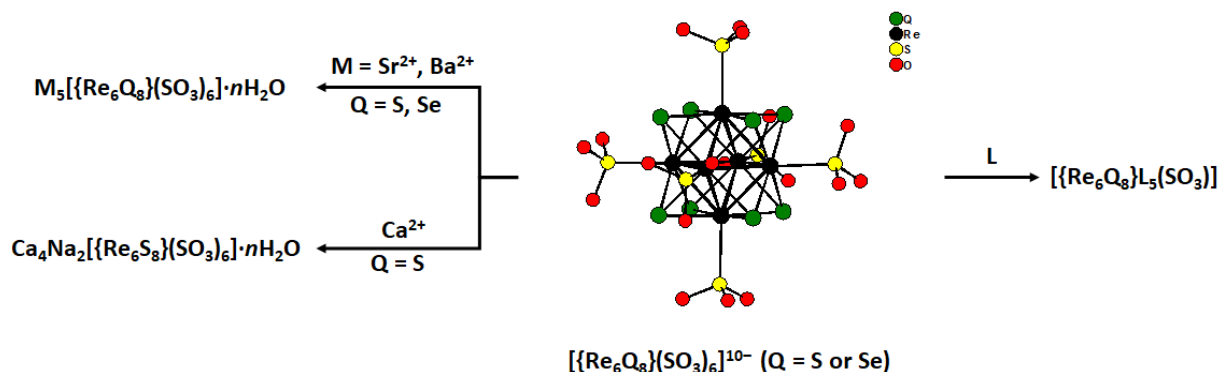
<sup>1</sup>Nikolaev Institute of Inorganic Chemistry SB RAS, Novosibirsk, Russia

PhD student

[kashnik@niic.nsc.ru](mailto:kashnik@niic.nsc.ru)

Hexarhenium octahedral complexes based on  $\{\text{Re}_6\text{Q}_8\}^{2+/3+}$  ( $\text{Q} = \text{S}, \text{Se}$  or  $\text{Te}$ ) cluster cores have been attracting a great attention over the last decades. The general formula of such complexes can be denoted as  $\{[\text{Re}_6\text{Q}_8]\text{L}_6\}^m$ , where  $\text{L} =$  organic or inorganic apical (outer) ligands. While the cluster core is a stable unit of the complex, apical ligands can be substituted or modified by various chemical reactions. This feature makes it possible not only to obtain new cluster complexes, but also to affect their physicochemical properties. Moreover, the judicious choice of outer ligands allows considering hexarhenium cluster complexes as attractive building blocks for supramolecular arrays. In 2019, our group reported two new complexes with six sulfite apical ligands  $[\{\text{Re}_6\text{S}_8\}(\text{SO}_3)_6]^{10-}$  and  $[\{\text{Re}_6\text{Se}_8\}(\text{SO}_3)_6]^{10-}$  [1]. To the best of our knowledge, they became the first examples of octahedral metal cluster complexes with so high negative charge. In addition, these complexes exhibit a bright red photoluminescence and can form colloids with  $\text{Gd}^{3+}$  ions, which possess great values of magnetic relaxivity [1]. In present work, we introduce our latest advances in studying reactivity and properties of these specific clusters.

It was found that reactions of  $[\{\text{Re}_6\text{Q}_8\}(\text{SO}_3)_6]^{10-}$  ( $\text{Q} = \text{S}$  or  $\text{Se}$ ) with neutral organic coordinating species  $\text{L}$  led to formation of mixed-ligand uncharged complexes with the  $[\{\text{Re}_6\text{Q}_8\}\text{L}_5(\text{SO}_3)]$  composition. It should be noted that there are not so many examples of hexarhenium octahedral clusters with such ratio of apical ligands, so the further study of ligand exchange reactions in  $[\{\text{Re}_6\text{Q}_8\}(\text{SO}_3)_6]^{10-}$  complexes can widely extend the number of apically heteroleptic  $\text{Re}_6$  cluster compounds. In addition, it turned out, that sulfite clusters have a great affinity to alkali earth metals. Insoluble crystal powders containing  $\text{Ba}^{2+}$ ,  $\text{Sr}^{2+}$  and  $\text{Ca}^{2+}$  cations and  $[\{\text{Re}_6\text{Q}_8\}(\text{SO}_3)_6]^{10-}$  anionic units were obtained from aqueous solutions. Some details on syntheses, structures and physicochemical properties of the above-mentioned compounds will be presented at the conference.



**Figure 1.** Reactions of  $[\{\text{Re}_6\text{Q}_8\}(\text{SO}_3)_6]^{10-}$  ( $\text{Q} = \text{S}$  or  $\text{Se}$ )

#### References

[1] Brylev K.A., Akhmadeev B.S., Elistratova J.G., Nizameev I.R., Gubaidullin A.T., Kholin K.V., Kashnik I.V., Kitamura N., Kim S.-J., Mironov Y.V., Mustafina A.R. *Inorg. Chem.* **2019**, *58*, 15889–15897.

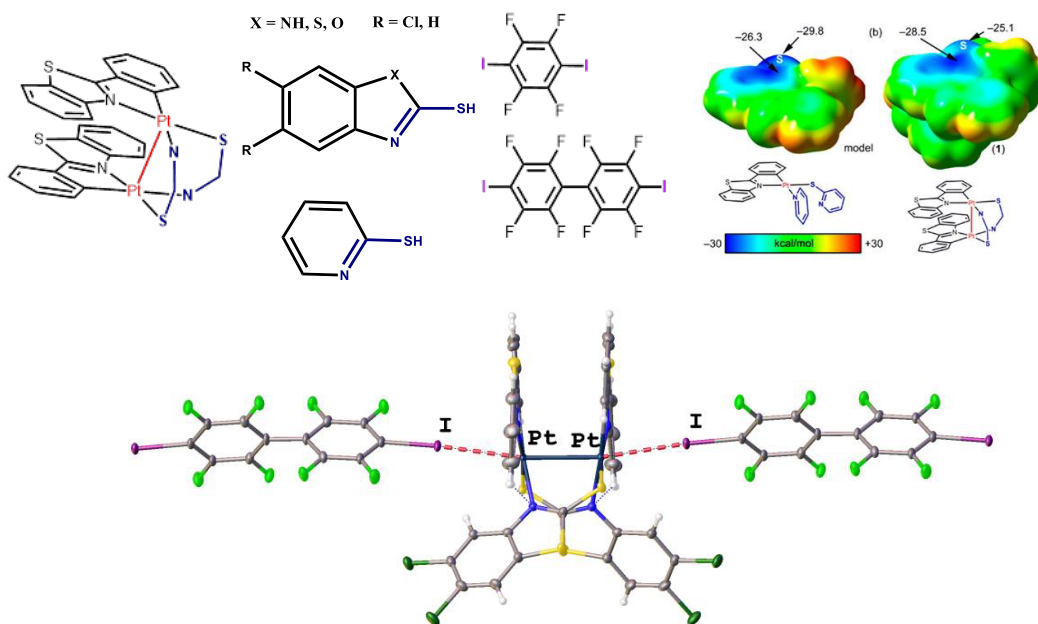
Acknowledgements. This work was supported by the Russian Science Foundation (project No 19-73-20196).

Katlenok E.A.<sup>1</sup><sup>1</sup>Saint Petersburg State University, Saint Petersburg, Russia

Young scientist

[195.08pt@gmail.com](mailto:195.08pt@gmail.com)

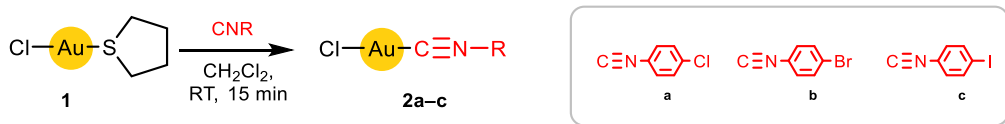
In this work the supramolecular assembly of binuclear cyclometallated complexes  $[\text{Pt}(\text{C}^{\wedge}\text{N})(\mu\text{-N}^{\wedge}\text{S})_2]_2$  ( $\text{C}^{\wedge}\text{N}$  - 2-phenylbenzothiazole and 1-phenylpyrazole derivatives,  $\text{N}^{\wedge}\text{S}$  - 2-mercaptopyridine and 2-mercaptobenzothiazole, 2-mercaptobenzimidazole, 2-mercaptobenzooxazole derivatives) adducts with haloarenes (1,4-diiodotetrafluorobenzene, 1,1'-diiodoperfluorobiphenyl) via a halogen bond was demonstrated. When 1,4-diiodotetrafluorobenzene is used, trimers of the  $\text{Pt}^{\text{II}}$  type  $\cdots\text{Pt}^{\text{II}}\cdots\text{I}(\text{Arene}^{\text{F}})\cdots\text{Pt}^{\text{II}}\cdots$  are formed, while the addition of 1,1'-diiodoperfluorobiphenyl leads to the formation of polymer chains  $\cdots\text{Pt}^{\text{II}}\cdots\text{I}(\text{Arene}^{\text{F}})\cdots\text{Pt}^{\text{II}}\cdots$ . It was found, that due to  $\text{Pt}^{\text{II}} - \text{Pt}^{\text{II}}$  orbital interaction, the basicity of the outer  $d_z^2[\text{Pt}^{\text{II}}]$  orbitals increase, which leads to the binding of the iodine atom to the  $\sigma$ -hole. According to DFT and NBO calculations, the interaction energy  $(\text{Arene})\text{I} \cdots d_z^2[\text{Pt}^{\text{II}}]$  is estimated from  $-12$  to  $-8$  kcal/mol, which is accompanied by a significant contribution of donor – acceptor interactions, indicating moderately strong halogen bonds in the supramolecular adduct performing important structure-forming function. The data obtained by CV,  $^{195}\text{Pt}$  NMR and molecular spectroscopy show that halogen bonds are retained in solution.



Acknowledgements. This work was supported by the Russian Science Foundation (project No 21-73-00056).

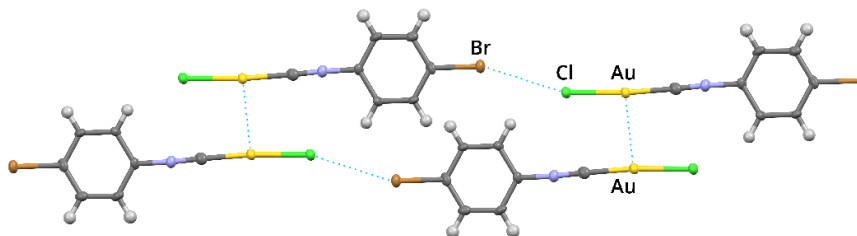
Over the past two decades, the field of application of gold-containing materials has been steadily expanding due to the fact that coordination compounds of gold exhibit unique catalytic, light-emitting, pharmaceutical and other practically useful properties [1-3].

The work studied *mono*isocyanide complexes of gold(I) with halogen-substituted arylisocyanide ligands (fig.1). The choice of halogen-substituted arylisocyanides is due to the fact that in the solid phase compounds can aggregate to form a combination of aurophilic interactions and halogen bonds [4]; in this case, the type and energy of halogen bonds will act as a structure-determining factor that sets the general packing motif and thereby determines the parameters of aggregate-induced luminescence.



**Figure 1.** Scheme of the synthesis of gold (I) halide complexes with isocyanide ligands.

According to X-ray diffraction data, all the complexes obtained have a linear structure of the coordination sphere of the metal center, which is in good agreement with the existing concepts of the structure of gold(I) complexes. In the structures of complexes with halogen-substituted aromatic isocyanides, the formation of supramolecular 1D polymers can be traced (fig.2).



**Figure 2.** Fragment of the structure of compound 2b.

The study of gold(I) complexes with halogen-substituted aryl isocyanide ligands showed that in the solid phase they can aggregate to form a combination of aurophilic interactions and/or halogen bonds. All synthesized compounds exhibit photoluminescence in the range of 400–500 nm, which corresponds to the spectrum blue.

### References

- [1] Alyabyev, S.B. and I.P. Beletskaya, *Russ. Chem. Rev.*, **2017**. 86, 689-749.
- [2] Seifert, T.P., et al, *Nanoscale*, **2020**. 12, 20065-20088.
- [3] Mora, M., M.C. Gimeno, and R. Visbal, *Chemical Society Reviews*, **2019**. 48, 447-462.
- [4] Kinzhalov, M.A., et al., *Angew. Chem. Int. Ed.*, **2018**. 57, 12785–12789.

**Acknowledgements.** This work was supported by the Russian Science Foundation (project No 21-73-10083). Measurements were performed at the Center for Magnetic Resonance, the Center for X-ray Diffraction Studies, the Center for Chemical Analysis and Materials Research, and the Chemistry Educational Centre (all belonging to Saint Petersburg State University).



# STUDY OF THE EFFECT OF PRELIMINARY MODIFICATION OF SOLUTIONS ON THE PROPERTIES OF NICKEL HYDROXIDE

*Kharisova K.A.<sup>1,2</sup>, Polivoda D.O.<sup>1</sup>, Kosykh A.S.<sup>1</sup>, Mashkovtsev M.A.<sup>1</sup>*

<sup>1</sup>Ural Federal University, Yekaterinburg, Russia

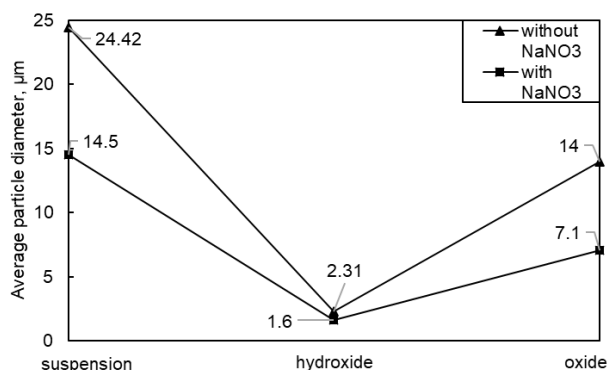
<sup>2</sup>Institute of High Temperature Electrochemistry of the Ural Branch of the Russian Academy of Sciences, Yekaterinburg, Russia

Student

[Ksenia.Kharisova@urfu.ru](mailto:Ksenia.Kharisova@urfu.ru)

Nickel compounds are widely used in the battery and power generation industries because of their high electrical conductivity, thermal and chemical stability, and low cost. An increase in the specific surface area and porosity of nickel hydroxide and oxide makes it possible to accelerate the catalytic reactions of materials due to an increase in the contact area with the electrolyte and the length of the three-phase boundary (TPB) in the SOFC anode [1]. Traditional methods for producing nickel hydroxide and oxide include electrochemical and chemical precipitation. The latter method involves the use of hydrothermal synthesis and hydrolysis in a urea medium at elevated temperatures [2], which increases the cost of obtaining materials. The controlled double-jet precipitation (CDJP) is a promising method to produce metal hydroxides from aqueous solutions. It makes it possible to control the properties of the precipitates obtained by varying the synthesis parameters and the modification of solutions of metals and a precipitant.

Nickel hydroxide was obtained by simultaneous dropwise of aqueous solutions of nickel nitrate and sodium hydroxide into the reaction volume while maintaining the pH value at 8 with constant stirring. The experiments were carried out in the absence and presence in the starting reaction volume of sodium nitrate (at a concentration of 1 mol/L). The resulting precipitates were dried in air at room temperature and calcined at 500 °C in a muffle furnace. The samples were studied by laser diffraction on an Analysette 22 NanoTec plus (Fritsch). The surface parameters of the synthesized oxides and hydroxides were studied using a Nova 1200e gas sorption analyzer (Quantachrome) by the BET method.



**Figure 1.** Average particle diameter

It was found that the addition of sodium nitrate to the initial reaction volume increases the average particle diameter of the precipitates after drying and calcining to oxides (Fig. 1). This can be explained by the partial negative charge on the particles, which are formed as a result of the selective absorption of  $\text{NO}_3^-$  ions. As a result, some  $\text{OH}^-$  ions cannot interact with the particle and increase its size, and therefore the number of particles in the system increases in comparison with the sample synthesized without the introduction of sodium nitrate - from  $6 \cdot 10^{11}$  to  $2 \cdot 10^{12}$  pcs. The abrupt change in the average diameter during heat treatment is explained by the decomposition of agglomerates during drying and coalescence of particles during heat treatment. The specific surface area of the oxide obtained with the addition of sodium nitrate was  $72 \text{ m}^2/\text{g}$ , which is higher than the value for the oxide obtained without the addition -  $28 \text{ m}^2/\text{g}$ . Sodium nitrate can act as a surface stabilizer and prevent the disappearance of pores in the material.

## References

- [1] Liu Y., Shao Z., Mori T., Jiang S. P. *Materials Reports: Energy* **2021**, *1*, 100003.
- [2] Paulose R., Mohan R., Parihar V. *Nano-Structures & Nano-Objects* **2017**, *11*, 102-111.

CRUCIAL IMPROVEMENT OF (INDENYL)RHODIUM COMPLEXES CATALYTIC ACTIVITY  
BY SIMPLE LIGAND MODIFICATION

*Kharitonov V.B.*<sup>1,2</sup>, *Loginov D.A.*<sup>1</sup>

<sup>1</sup> A.N.Nesmeyanov Institute of Organoelement Compounds of Russian Academy of Sciences

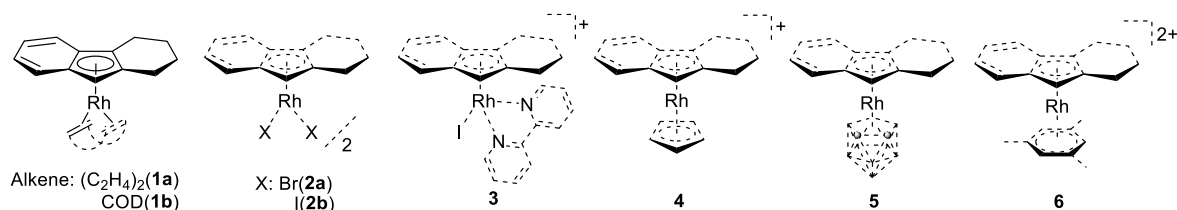
<sup>2</sup> Dmitry Mendeleev University of Chemical Technology of Russia, Moscow, RUSSIA

Student

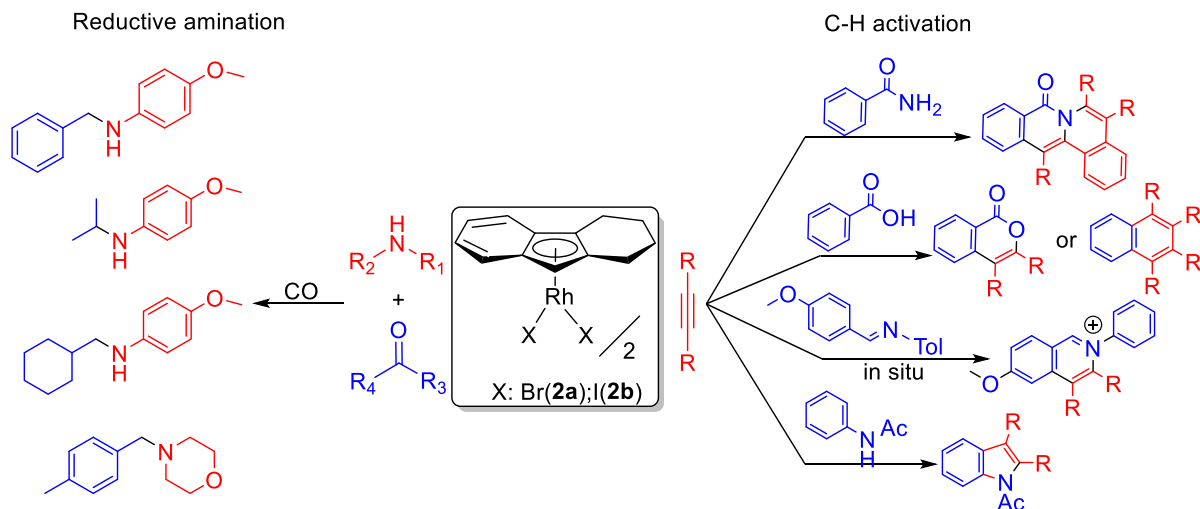
[kharitonov55@yandex.ru](mailto:kharitonov55@yandex.ru)

Nowadays, rhodium complexes are widely spread in homogeneous catalysis. Most of them are based on cyclopentadienyl ligand, which supports rhodium atom in a catalytic cycle. Indenyl ligand is isolobal to cyclopentadienyl one and can also be used as a supporting ligand. Although the numerous examples of indenyl rhodium complexes have been used in catalysis [1,2], they are poorly suitable for most of C-H activation processes due to weak indenyl-rhodium bond. This problem can be solved by indenyl functionalization, such as introduction of methyl substituents into the indenyl ligand [3,4]. However, the methylated indenenes are not available, because their synthesis requires multi-step procedures.

Herein we report a simple approach to tetrahydrofluorenyl rhodium complexes, which are more stable as compared with unsubstituted indenyl analogs. In particular, complexes with different auxiliary ligands: alkene, halogen, bipyridyl, cyclopentadienyl, arene, and dicarbollide were synthesized (Scheme 1). The halide derivatives **2a,b** showed high catalytic activity in numerous catalytic processes of C-C and C-N bond construction (Scheme 2). X-ray structures and mechanistic details of some processes will be also discussed.



**Scheme 1.** The compounds prepared



**Scheme 2.** The investigated catalytic reactions

**References**

- [1] V. B. Kharitonov, D. V. Muratov, D. A. Loginov *Coord. Chem. Rev.*, **2019**, 399, 1-24  
 [2] V. B. Kharitonov, E. Podyacheva, Y. V. Nelyubina, D. V. Muratov, A. S. Peregudov, G. Denisov, D. Chusov, D. A. Loginov *Organometallics* **2019**, 38, 16, 3151–3158  
 [3] J. Terasawa, Y. Shibata, Y. Kimura, K. Tanaka *Chem. Asian J.* **2018**, 13, 505.  
 [4] N. Semakul, K. E. Jackson, R. S. Paton, T. Rovis *Chem. Sci.*, **2017**, 8, 1015-1020

Acknowledgements. This work was supported by the Russian Science Foundation (Grant No. 19-73-20212).

SO CLOSE BUT DIFFERENT: Pt(II) AND Pd (II) BINUCLEAR CYCLOMETALATED COMPLEXES OF THE TRIDENTATE N<sup>^</sup>N<sup>^</sup>C AND N<sup>^</sup>C<sup>^</sup>N LIGANDS

*Khistiaeva V.V.*<sup>1,2</sup>, *Grachova E.V.*<sup>1</sup>, *Koshevoy I.O.*<sup>2</sup>

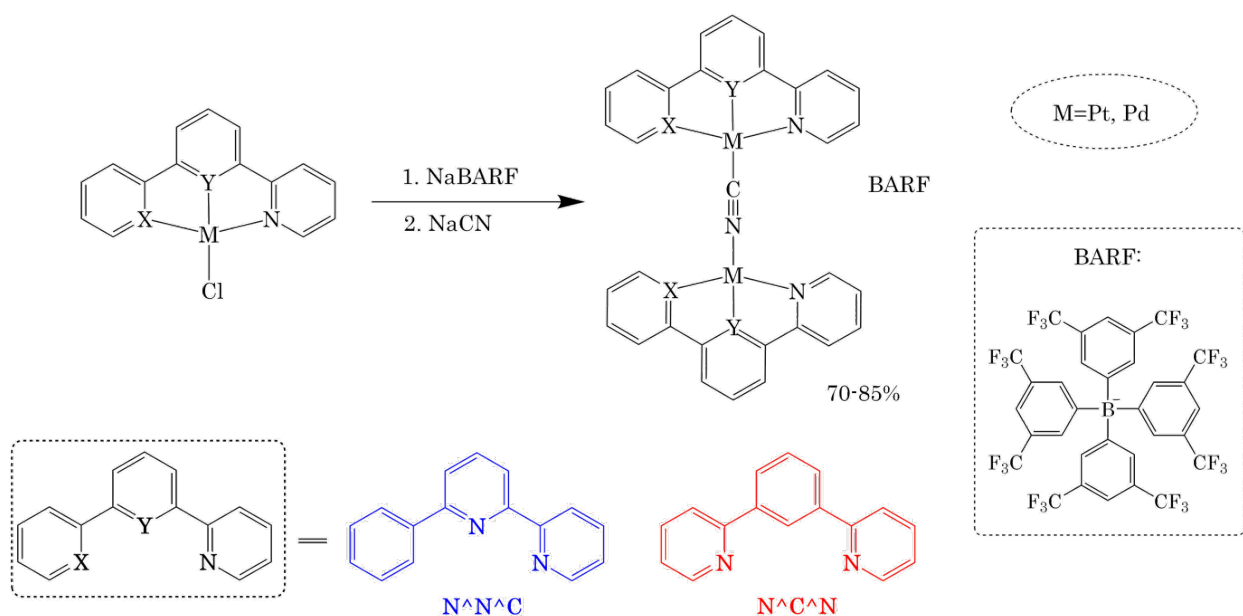
<sup>1</sup>Saint Petersburg State University, Saint Petersburg, Russia

<sup>2</sup>University of Eastern Finland, Joensuu, Finland

PhD Student

[v.v.khist@gmail.com](mailto:v.v.khist@gmail.com)

Cyclometalated Pt(II) and Pd (II) complexes have been attracting attention due to their unusual photophysical properties depending on variable weak interactions [1]. Such weak interactions as intermolecular  $\pi$ - $\pi$  stacking and metal orbitals overlap usually cause bathochromic shift in emission bands in comparison with the isolated monomeric species [2,3]. This feature affects luminescent intensity and color tunability. However, being neighboring metals in one group, Pt(II) and Pd(II) surrounded with the same ligand environment demonstrate distinct photophysical behavior. Metallophilic interaction in Pd(II) complexes in contrast to Pt(II) species is significantly more distance-demanding, thus resulting in a far less examples in the literature [4]. In this regard, the study and comparison of square-planar complexes based on Pt(II) and Pd(II) are of high interest.



**Figure 1.** Synthesis of the binuclear complexes

In this work we describe preparation of binuclear  $[M(N^N^C)_2]_2CN(BARF)$  and  $[M(N^C^N)_2]_2CN(BARF)$  ( $M=Pt, Pd$ ) complexes and compare their photophysical properties.  $N^N^C$  and  $N^C^N$  ligands were chosen in terms of scaffold isomerization. The results obtained reveal the significant difference between aggregation capacity of the objects.

### References

- [1] Wei Lu, Yong Chen, Chi-Ming Che, *Angew. Chem. Int. Ed.* **2009**, 48, 7621–7625
- [2] Q. Zheng, S. Borsley, S. Cockroft, *Chem. Commun.* **2020**, 56, 14705
- [3] V. Sivchik, E. Grachova, I. Koshevoy, *Inorg. Chem.* **2016**, 55, 3351–3363
- [4] C. Zou, J. Lin, W. Lu, *Chem. Commun.*, **2018**, 54, 5319

**Acknowledgements.** This work was supported by the Russian Science Foundation, project 21-13-00052. The studies were performed using the equipment of Centres for Magnetic Resonance and for Chemical Analysis and Materials Research (Research Park of St. Petersburg State University).

# SYNTHESIS, STRUCTURE, OPTICAL AND ELECTROCHEMICAL PROPERTIES OF CYCLOMETALLATED COMPLEXES OF RHODIUM(III) AND IRIIDIUM (III) WITH AROMATIC $\beta$ -DIKETONES

*Kiseleva M.A.*<sup>1,2</sup>, *Zakharov A.Yu.*<sup>1</sup>, *Bezzubov S.I.*<sup>1</sup>

<sup>1</sup> Kurnakov Institute of General and Inorganic Chemistry, Russian Academy of Sciences, Russia

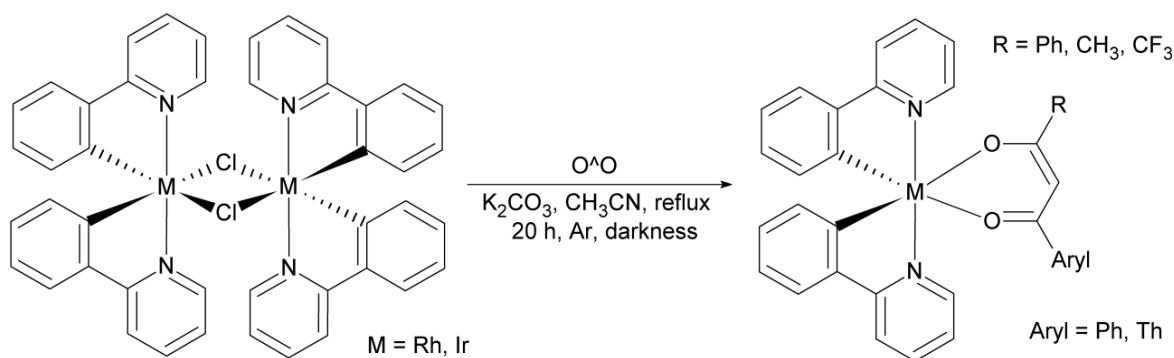
<sup>2</sup> Lomonosov Moscow State University, Russia

Student

[marina.kiseleva@chemistry.msu.ru](mailto:marina.kiseleva@chemistry.msu.ru)

Cyclometallated complexes of platinum metals have been used as photosensitizing dyes in DSSC. However, the improvement of the device requires knowledge of how the variation of ligands or metals affects the target optical and electrochemical characteristics of the dye and its stability. Among metal-based dyes iridium(III) complexes appeared to be the most stable and they have been successfully examined in solar cells while their rhodium(III) analogues have not.

In line with this, the aim of the work was to disclose how the replacement of iridium (III) by rhodium(III) in heteroleptic cyclometallated complexes affects their optical and redox properties, and to identify correlations between substituents in the  $\beta$ -diketonate ancillary ligand and the above-mentioned properties of the complexes. For this purpose, two similar sets of cyclometallated rhodium (III) and iridium (III) complexes with 2-phenylpyridine and various aromatic  $\beta$ -diketones were synthesized. The resulting compounds were characterized by <sup>1</sup>H NMR, high-resolution mass spectrometry, and X-ray diffraction.



**Scheme 1.** Synthesis of cyclometallated complexes.

UV-Vis spectroscopy showed noticeable shifts of the long-wavelength maxima in the spectra of the complexes upon the variation of the substituents in  $\beta$ -diketones while the change of the metal dramatically altered the UV-Vis spectra. In turn, the variation of  $\beta$ -diketones resulted in just a modulation of redox potentials of the complexes and considerable shifts were achieved by the change of the central ion.

Acknowledgements. This work was supported by the Russian Science Foundation (project No 17-73-10084).

## INTERIONIC ASSOCIATION OF DIARYLIODONIUM THIOCYANATES AND SELENOCYANATES

*Kissler T. Yu.*<sup>1</sup>, *Ivanov D. M.*<sup>1,2</sup>, *Soldatova N. S.*<sup>2,1</sup>

<sup>1</sup> Institute of Chemistry, Saint Petersburg State University, Saint Petersburg 199034, Russia

<sup>2</sup> Tomsk Polytechnic University, Tomsk 634034, Russia

Student

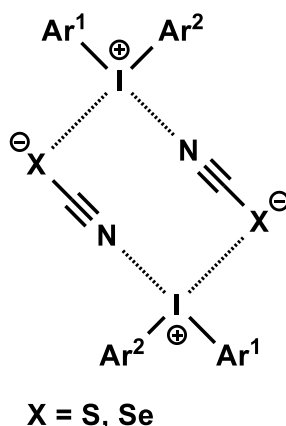
[st068571@student.spbu.ru](mailto:st068571@student.spbu.ru)

Halogen bonding (XB) is a type of intermolecular interactions, where halogen atoms serve as electrophilic centers [1]. This type of interactions is actively investigated in recent years and can be employed in material science, catalysis, and biochemistry of halogen containing compounds.

XB may be formed both between electroneutral particles and ions. Diaryliodonium cations  $[Ar_2I]^+$  are typical cationic XB donors toward halide and pseudohalide anions. For thiocyanate anion  $SCN^-$ , only few examples of interionic XBs with I-centered cationic electrophiles were reported [2-4].

Although selenocyanate  $SeCN^-$  is an analog of thiocyanate, no interionic XBs with  $SeCN^-$  were reported, and halogen bonds involving this nucleophile are known only with neutral iodine(I) XB donors [5].

In this work, we reported synthesis and crystallization of diaryliodonium thiocyanates  $[Ar_2I]SCN$  [6-7] and selenocyanates  $[Ar_2I]SeCN$ . In solid state, the XB supported interionic interactions (**Figure 1**) were found by single-crystal X-ray diffraction experiments. The existence and nature of noncovalent interactions were studied by following theoretical calculations.



**Figure 1.** Heterotetrameric supramolecular aggregation in diaryliodonium thiocyanates and selenocyanates.

### References

- [1] G. R. Desiraju, P. S. Ho, L. Kloo, A. C. Legon, R. Marquardt, P. Metrangolo, P. Politzer, G. Resnati, K. Rissanen. *Pure Appl. Chem.* **2013**, *85*, 1711–1713
- [2] A. M. S. Riel, M. J. Jessop, D. A. Decato, C. J. Massena, V. R. Nascimento, O. B. Berryman. *Acta Cryst.* **2017**, *B73*, 203–209.
- [3] P. S. Postnikov, O. A. Guselnikova, M. S. Yusubov, A. Yoshimura, V. N. Nemykin, V. V. Zhdankin. *J. Org. Chem.*, **2015**, *80*, *11*, 5783–5788
- [4] M. E. Hirschberg, P. Barthen, H.-J. Frohn, D. Bläser, B. Tobey, G. Jansen. *J. Fluor. Chem.*, **2014**, *163*, 28–33.
- [5] Jasmine Viger-Gravel, Ilia Korobkov, David L. Bryce. *Cryst. Growth Des.* **2011**, *11*, *11*, 4984–4995
- [6] N. S. Soldatova, V. V. Suslonov, T. Y. Kissler, D. M. Ivanov, A. S. Novikov, M. S. Yusubov, P. S. Postnikov, V. Y. Kukushkin. *Crystals* **2020**, *10*, 230.
- [7] N. S. Soldatova, P. S. Postnikov, V. V. Suslonov, T. Y. Kissler, D. M. Ivanov, M. S. Yusubov, B. Galmes, A. Frontera, V. Y. Kukushkin. *Org. Chem. Front.* **2020**, *7*, 2230–2242

Acknowledgements. The proposed research was supported by The Ministry of Science and High Education of Russian Federation in frame of 220PP project (number 2020-220-08-8827).

## OXIDATION OF OCTANOL-2 WITH PLATINOCHLORIC ACID

*Klimova N.V.<sup>1</sup>, Ivanov A.G.<sup>1</sup>, Lebedev A.V.<sup>1</sup>, Kuznetsova M.G.<sup>1</sup>*

<sup>1</sup>SSC RF JSC "GNIIChteOS", Moscow, Russia

Graduate student

[natalia.fresh@yandex.ru](mailto:natalia.fresh@yandex.ru)

Spier's catalyst, which is a 0.1N solution of  $\text{H}_2\text{PtCl}_6 \cdot 6\text{H}_2\text{O}$  in isopropyl alcohol [1], has been widely used in hydrosilylation [2] and dehydrocondensation [3] reactions.

It was noted [4] that during storage of the Spier's catalyst, acetone, HCl, and  $\text{H}_2\text{PtCl}_4$  appear in its composition. This indicates a partial reduction of  $\text{Pt}^{\text{IV}}$  to  $\text{Pt}^{\text{II}}$ . With prolonged storage, the content of HCl and acetone increases; therefore, an absorption band in the region of  $1705\text{ cm}^{-1}$  appears and intensifies in the IR spectrum, and the reduction of  $\text{Pt}^{\text{IV}}$  and  $\text{Pt}^{\text{II}}$  proceeds even deeper (to  $\text{Pt}^0$ ), as evidenced by the release of metallic platinum. Thus, platinum can be present in the catalyst in several forms.

The results of studies of the Spier's catalyst with a two-week exposure allowed informing the authors of [5] that the Spier's catalyst contains in its composition the complex  $\text{H}[(\text{C}_3\text{H}_6)\text{PtCl}_3]$ .

We prepared, by analogy with Spier's catalyst, a solution of hydrogen hexachloroplatinate in 2-octanol. Changes in its composition on heating were observed by IR spectrometry,  $^{13}\text{C}$  NMR spectroscopy, and GLC.

After 11 hours, a black precipitate was observed - metallic platinum. The study of the reaction mass by IR spectrometry made it possible to record an intense absorption band in the region of  $1712\text{ cm}^{-1}$ , which is characteristic of  $\nu$  for the  $\text{C}=\text{O}$  bond. A chemical shift in the region of 208 ppm appeared in the  $^{13}\text{C}$  NMR spectrum, which also confirmed the formation of octanone-2. This fact was also confirmed by GLC. The formation of octene-1 and octene-2 was not confirmed by any of the above methods of analysis. Based on the foregoing, we propose the following reaction scheme (Fig. 1).

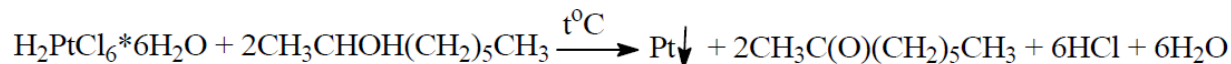


Figure 1.

### References

- [1] Speier J.L., Webster J.A., Barnes G.H. *J. Amer. Chem. Soc.*, **1957**, 79, 954.
- [2] Harrod J.F., Chalk A.J. *J. Amer. Chem. Soc.*, **1964**, 86, 1776.
- [3] E. Lukevics, M. Dzintara. *J. Organomet. Chem.*, **1985**, 295, 265-315.
- [4] Voronkov M.G., Pukhnarevich V.B., Sushinskaya S.P., Kopylova L.I., Trofimov B.A. *ZHOKh*, **1971**, 2102.
- [5] Benkeser R.A., Kang J. *J. Organomet. Chem.*, **1980**, 185, 9.

# INFLUENCE OF FLUOROSUBSTITUTION ON THE STRUCTURAL FEATURES AND SENSOR PROPERTIES OF METAL PHTHALOCYANINE THIN FILMS

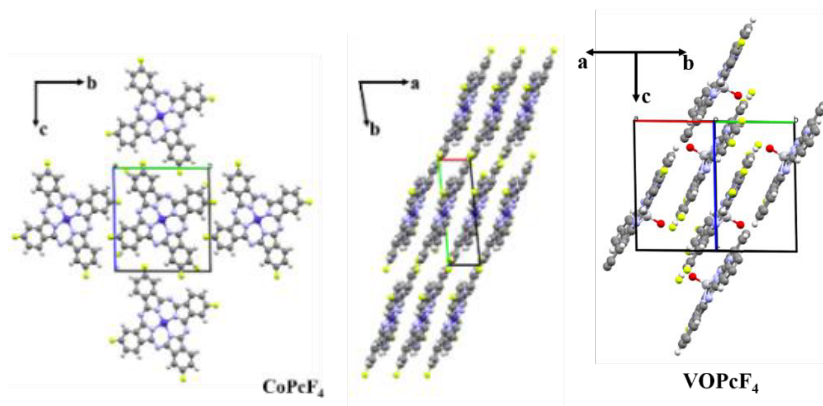
*Klyamer D.D.<sup>1</sup>, Sukhikh A.S.<sup>1</sup>, Basova T.V.<sup>1</sup>*

<sup>1</sup>Nikolaev Institute of Inorganic Chemistry SB RAS, Novosibirsk, Russia  
Young Scientist

[klyamerdarya@yandex.ru](mailto:klyamerdarya@yandex.ru), [klyamer@niic.nsc.ru](mailto:klyamer@niic.nsc.ru)

One of the important and rapidly developing directions of modern medicine is non-invasive diagnostics of bronchopulmonary, cardiovascular, gastrointestinal and other diseases. The change of the composition of components released during exhalation can point to the presence of a disease. For example, ammonia concentration more than 1 ppm indicates renal failure in nephritis, atherosclerosis of renal arteries, toxic affections of kidneys and other diseases [1-2]. Among numerous organic semiconductors, thin films of fluorinated phthalocyanine (MPc) derivatives are of considerable interest as active layers of chemiresistive sensors because of their high thermal and chemical stability combined with their unique electronic properties. Introduction of various substituents into the phthalocyanine macrocycle can significantly alter the films structure and morphology and in its turn leads to the change of their electrical and sensing properties. It is known that the influence of F-substitution on the orientation/morphology of the obtained films of investigated phthalocyanines will allow to change and improve their conductivity and sensor properties.

In this work, tetrafluorosubstituted and hexadecafluorosubstituted metal phthalocyanines  $\text{MPcF}_x$  ( $x = 4, 16$ ;  $M = \text{Co, Cu, Fe, Pd, VO, Pb}$ ) were investigated. Structures of single crystals of  $\text{MPcF}_x$  were also determined (fig. 1). Thin films of the investigated metal phthalocyanines deposited by organic molecular beam deposition were studied as promising chemiresistive active layers for the selective detection of low concentrations of ammonia (0.1-50 ppm). A combination of spectroscopy methods and X-ray diffraction techniques were used to reveal the effect of F-substituents on the phthalocyanine thin films structure. Sensor properties of  $\text{MPcF}_x$  films toward gaseous  $\text{NH}_3$  (0.1-50 ppm) were studied by chemiresistive method and also compared to those of unsubstituted MPc to reveal the effects of F-substituents on the sensing performance. The sensor properties of the films before and after annealing, toward ammonia in the presence of  $\text{CO}_2$  and vapors of water and volatile organic compounds as well as in a gas mixture simulating exhaled air were investigated. All investigated films demonstrated fully reversible sensor response toward ammonia, had rather low response and relaxation times and low detection limits. It was shown that  $\text{MPcF}_4$  films demonstrated the best sensor response to ammonia in the presence of some interfering gases and were promising active layers for chemiresistive sensors for the detection of ammonia in exhaled air.



**Figure 1.** Molecular packing of  $\text{CoPcF}_4$  and  $\text{VOPcF}_4$ .

## References

- [1] C. Di Natale, R. Paolesse, E. Martinelli, R. Capuano, *Anal. Chim. Acta* **2014**, 824, 1-17.
- [2] N.T. Brannelly, J. P. Hamilton-Shield, A. J. Killard, *Critical Rev. in Anal. Chem.* **2016**, 46, 490-501.

Acknowledgements. This work was supported by the Russian Science Foundation (project No 20-73-00080).

DESIGN OF MANGANESE CLUSTERS BASED ON (THIA)CALIX[4]ARENES WITH CONTROLLED MAGNETIC PROPERTIES IN THE CRYSTALLINE PHASE

*Kniazeva M.V.*<sup>1,2</sup>, *Ovsyannikov A.S.*<sup>1,2</sup>, *Khanova L.M.*<sup>2</sup>, *Islamov D.R.*<sup>1,2</sup>, *Samigullina A.I.*<sup>1,2</sup>, *Gubaidullin A.T.*<sup>1,2</sup>, *Batulin R.G.*<sup>2</sup>, *Cherosov M.A.*<sup>2</sup>, *Solovieva S.E.*<sup>1,2</sup>, *Antipin I.S.*<sup>1,2</sup>

<sup>1</sup> Arbuzov Institute of Organic and Physical Chemistry, FRC Kazan Scientific Center, Russian Academy of Sciences, Kazan, Russia

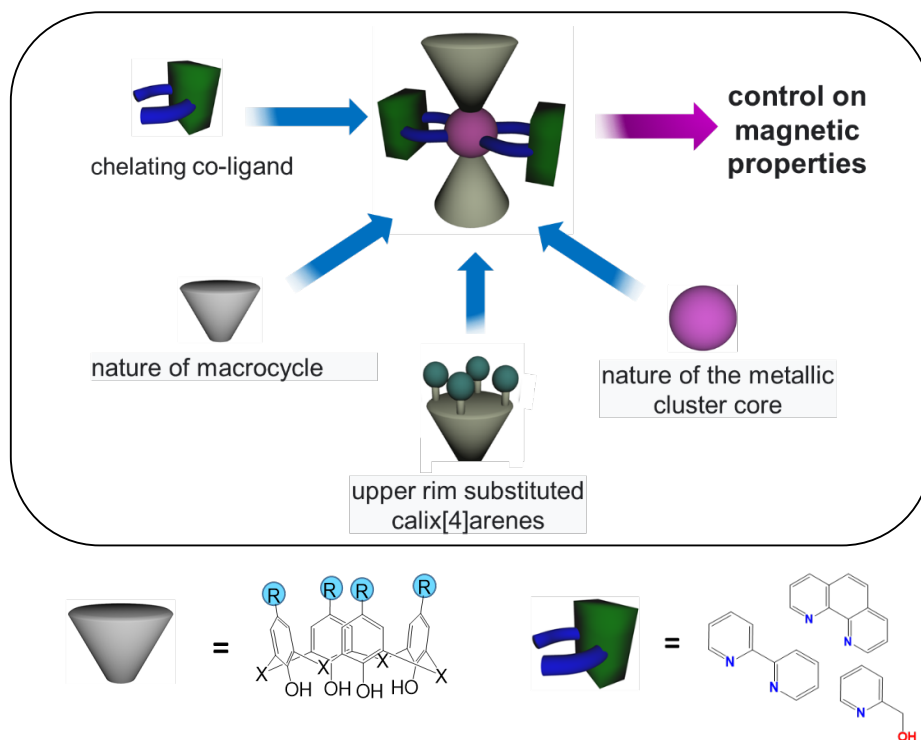
<sup>2</sup> Kazan Federal University, Kazan, Russia

PhD student

[kniazeva255@gmail.com](mailto:kniazeva255@gmail.com)

Calix[4]arenes in the *cone* conformation are attractive polydentate ligands for formation of discrete supramolecular structures (clusters) with both of d- and f-elements displaying different functional properties, for example, monomolecular magnetism (SMM) [1-3]. The using of the upper rim substituted macrocycles, the involvement of chelating co-ligands in the coordination sphere and a varying of nature of metallic cluster core (Scheme 1) make possible to control the magnetic properties of resulting metal clusters.

This work reports on the synthesis and study of the structure of homometallic manganese and heterometallic manganese/lanthanide clusters based on (thia)calix[4]arene (X=CH<sub>2</sub>, S) and their upper rim derivatives bearing substituents of different nature (R = -H, -tBu, -Adamantyl, -NO<sub>2</sub>). In addition, the influence of chelating co-ligand (pyridylmethanol, bipyridine, phenanthroline) on the magnetic properties of the obtained metal clusters will be discussed.



**Scheme 1.** Design of new magnetically active clusters using calix[4]arenes (X = CH<sub>2</sub>) and thiacalix[4]arenes (X = S) containing different substituents on the upper rim (R = tBu-, Adamantyl-, H, -NO<sub>2</sub>) and chelating co-ligands.

#### References

- [1] Aldoshin, S. M.; Sanina, N. A.; Solovieva, S. E.; Antipin, I. S.; Dmitriev, A. I.; Morgunov, R. B. *Russ.Chem.Bull., Int.Ed.*, **2013**, 62, 536542
- [2] S. J. Dalgarno et al., *Chem.Eur. J.*, **2011**, 17, 7521
- [3] Aldoshin, S.M., Antipin, I.S., Kniazeva, M.V., Korchagin, D.V., Morgunov, R.B., Ovsyannikov, A.S., Palii, A.V., Sanina, N.A., Shilov, G.V., Solovieva, S.E., *Israel Journal of Chemistry*, **2020**, 60, 600.

Acknowledgements. This work was supported by the Russian Science Foundation (project No 19-73- 20035).



# DESIGN, SYNTHESIS AND APPLICATION OF Ir(III) COMPLEX FOR FRET-BASED INTRACELLULAR pH-MEASUREMENT

*Koblova A.A.*<sup>1</sup>, *Shakirova J.R.*<sup>1</sup>

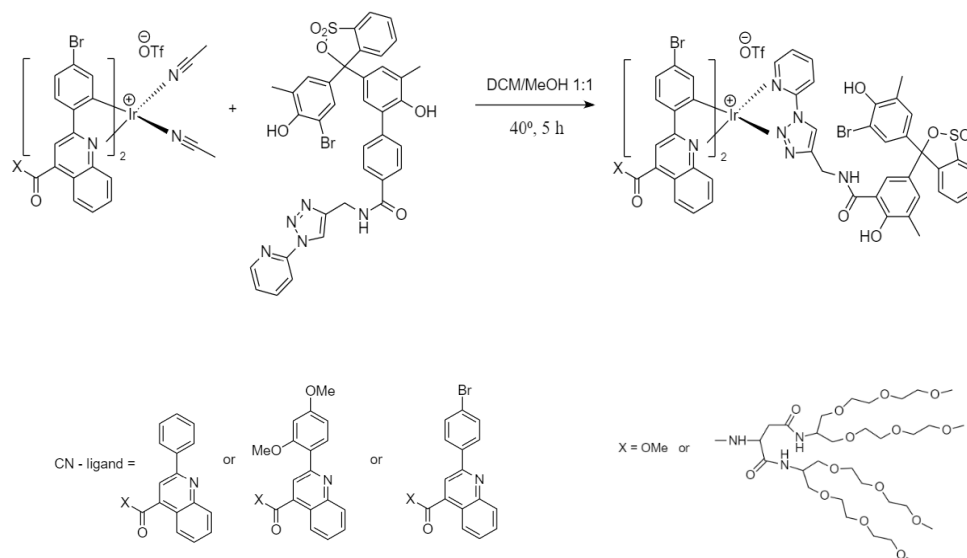
<sup>1</sup>Saint Petersburg State University, Saint Petersburg, Russia

Student

[st055890@spbu.student.ru](mailto:st055890@spbu.student.ru)

pH value is a crucial parameter for biological systems, playing a vital role in physiological processes, such as transmission of nerve impulses, ion transport and protein metabolism. It is therefore possible to detect cancer and Alzheimer's among other diseases, based on intracellular pH measurement. Nowadays there is a significant demand for high precision *in vivo* pH-sensors development in the field of biochemistry and pharmacology. [1,2]

In the course of our research we have designed, synthesized and investigated the photophysical properties of Ir(III) phosphorescent complexes (Figure 1), demonstrating a linear pH-dependency of the analytical signal. In our study we have exploited the Förster resonance energy transfer (FRET) mechanism to create a sensor for *in vitro* pH-measurements based on phosphorescence lifetime imaging (PLIM). Moreover, hydrophilic oligoethylenglycol fragments were introduced to the CN-ligand structure of the Ir(III) complex (donor), along with a pH-sensitive NN-ligand (acceptor). The NN-ligand absorption band undergoes a significant shift once the pH is changed, which in turn alters FRET-pair spectral overlap.



**Figure 1.** Ir(III) phosphorescent complexes, demonstrating a FRET-based luminescence pH-dependency

## References

- [1] Hou, J.-T., Ren, W. X., Li, K., Seo, J., Sharma, A., Yu, X.-Q., & Kim, J. *Chemical Society Reviews* **2017**, *46*, 2076–2090
- [2] Draxler, S., & Lippitsch, M. E. *Sensors and Actuators B: Chemical* **1995**, *29*, 199–203

**Acknowledgements.** This work was supported by the Russian Science Foundation (project No 19-13-00132). The work was carried out using equipment of the Research park of St. Petersburg State University (Centres for Magnetic Resonance, for Optical and Laser Materials Research, for Chemical Analysis and Materials Research, for X-ray Diffraction Studies, and Computing Center).

EXTREMELY BULKY RHODIUM(III) CATALYST WITH CYCLOPENTADIENYL LIGAND ASSEMBLED BY CYCLOTETRAMERIZATION OF TERT-BUTYL-ACETYLENE

Kolos A.V.<sup>1</sup>, Nelyubina Y.V.<sup>1</sup>, Perekalin D.S.<sup>1</sup>

<sup>1</sup>A.N. Nesmeyanov Institute of Organoelement Compounds RAS, Moscow, Russia

Student

[Kolos.Andreij@gmail.com](mailto:Kolos.Andreij@gmail.com)

Half-sandwich rhodium complexes with cyclopentadienyl ligands are widely used as catalysts for various organic transformations, most notably for activation of C–H bonds in arenes.[1,2] Herein we describe the synthesis of new rhodium catalyst for such reactions. The intriguing feature of this catalyst is the bulky planar-chiral cyclopentadienyl ligand, which was constructed from four molecules of tert-butyl-acetylene (Figure 1).

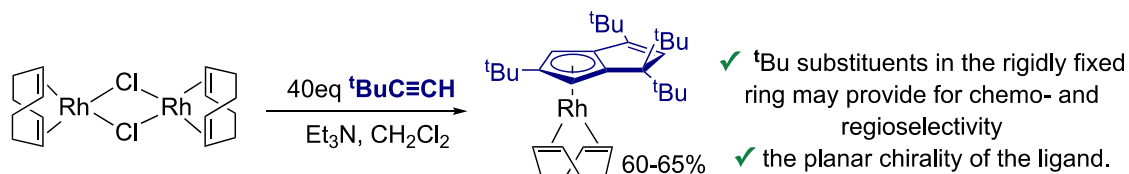


Figure 1. Formation of (<sup>t</sup>Bu<sub>4</sub>Cp)Rh(cyclooctadiene).

Oxidation of the rhodium(I) complex (<sup>t</sup>Bu<sub>4</sub>Cp)Rh(cyclooctadiene) with chlorine or bromine gave the rhodium(III) complexes (<sup>t</sup>Bu<sub>4</sub>Cp)RhX<sub>2</sub> (X = Cl, Br) in high yields (Figure 2). The X-ray diffraction studies revealed that complexes are monomeric despite having unsaturated 16-electron metal centers. The racemic chloride complex had been separated into enantiomers by the preparative thin-layer chromatography in the presence of *R*-phenylglycinol.

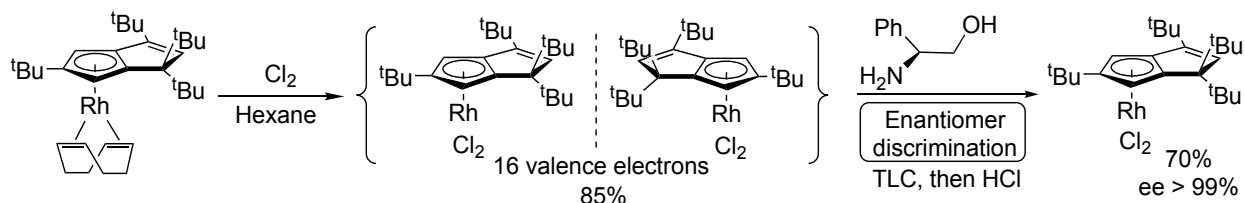


Figure 2. Synthesis and structures of Rh(III) halide complexes with <sup>t</sup>Bu<sub>4</sub>Cp ligand.

Complex <sup>t</sup>Bu<sub>4</sub>CpRhCl<sub>2</sub> catalyzed the reactions of *O*-pivaloyl-phenylhydroxamate with unsubstituted ethylene and acetylene giving the corresponding heterocycles in excellent yields (Figure 3). Similar reactions with substituted substrates such as 1-hexene and 1-hexyne gave low yields of products with moderate enantioselectivity.

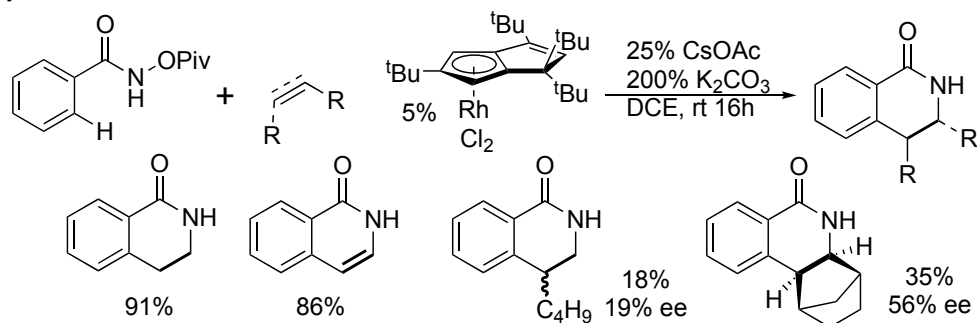


Figure 3. Catalytic performance of the complex <sup>t</sup>Bu<sub>4</sub>CpRhCl<sub>2</sub> in annulation of *O*-pivaloyl-phenylhydroxamate

References

- [1] Song, G., Wang, F., Li, X. *Chem. Soc. Rev.* **2012**, *41*, 3651–3678.  
 [2] Piou, T., Rovis, T. *Acc. Chem. Res.* **2018**, *51*, 170–180.

Acknowledgements. This work was supported by the Russian Foundation for Basic Research (project No 19-53-45035).

QUASI-AROMATIC MÖBIUS CADMIUM(II) COMPLEXES FABRICATED FROM THE BULKY N6  
TETRADENTATE HELICAL LIGAND IN DIFFERENT SOLVENTS

*Konyaeva I.A.*<sup>1,2</sup>, *Mahmoudi G.*<sup>3</sup>, *Mitoraj M.P.*<sup>4</sup>, *Safin D.A.*<sup>5</sup>

<sup>1</sup>«NIOST» LLC, Kuzovlevski trakt 2, 634067, Tomsk, Russia

<sup>2</sup>Research School of Chemistry & Applied Biomedical Sciences, National Research Tomsk Polytechnic University, 43-A Lenin ave., 634050 Tomsk, Russia

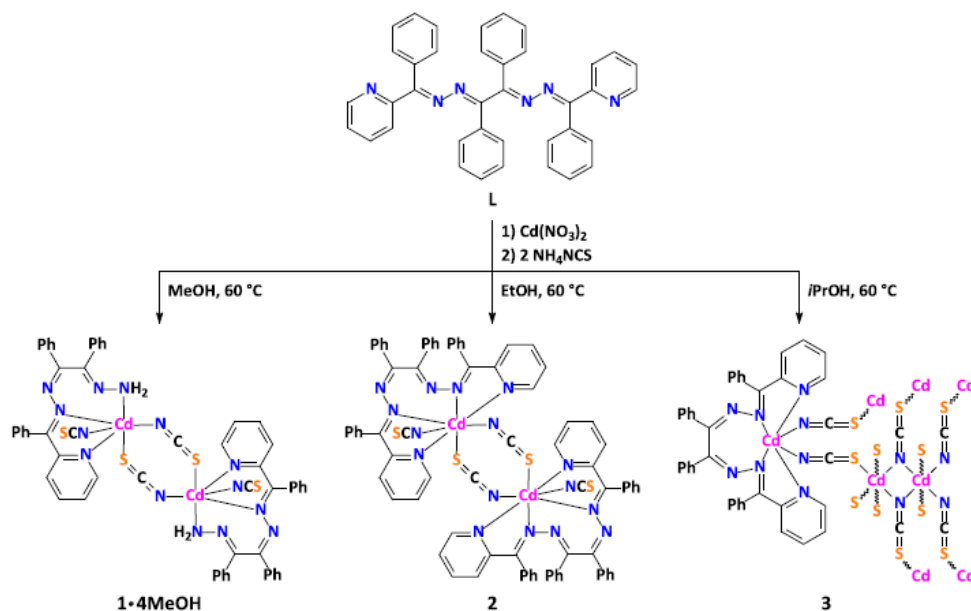
<sup>3</sup>Department of Chemistry, Faculty of Science, University of Maragheh, P.O. Box 55181-83111, Maragheh, Iran

<sup>4</sup>Department of Theoretical Chemistry, Faculty of Chemistry, Jagiellonian University, R. Gronostajowa 2, 30-387 Cracow, Poland

<sup>5</sup>University of Tyumen, Perekopskaya Str. 15a, 625003 Tyumen, Russia

[konyaevaia@niost.sibur.ru](mailto:konyaevaia@niost.sibur.ru)

Coordination polymers derived from transition metals have been of ever-growing interest as materials with different properties of value. We report synthesis and characterization of discrete dinuclear heteroleptic complex  $[\text{Cd}_2(\mu_{1,3}\text{-NCS})_2(\text{NCS})_2(\text{L})_2] \cdot 4\text{MeOH}$  ( $1 \cdot 4\text{MeOH}$ ), where L' is the product obtained by hydrolysis of one of the 2-PyC(Ph) groups of the parent ligand 1,2-diphenyl-1,2-bis-((phenyl(pyridin-2-yl)methylene)hydrazono)ethane (L). Complex was synthesized from a mixture of  $\text{Cd}(\text{NO}_3)_2 \cdot 4\text{H}_2\text{O}$  and  $\text{NH}_4\text{NCS}$  in methanol. Using of EtOH and iPrOH as reaction media, crystals of the discrete dinuclear heteroleptic complex  $[\text{Cd}_2(\mu_{1,3}\text{-NCS})_2(\text{NCS})_2(\text{L})_2]$  (**2**) and polymeric complex of the composition  $[\text{Cd}_3(\text{NCS})_6(\text{L})_n]$  (**3**), respectively, were obtained (Figure 1). Solvents used act as a structure-directing medium, yielding various types of complexes with the same reagents. Bulky helical ligand L in the isolated complexes shows an uncommon example of quasi-aromatic Möbius motif due to different types of  $\pi$ -interactions in each complex. At the same time the  $\text{Cd}^{\text{II}}$  atom does not directly participate in delocalization [1].



**Figure 1.** Synthesis of Complexes.

### References

[1] Mitoraj, M. P.; Mahmoudi, G.; Afkhami, F.A.; Castineiras, A.; Giester, G.; Konyaeva, I. A.; Khandar, A. A.; Qu, F.; Gupta, A.; Sagan, F.; Szczepanik, D. W.; Safin, D. A. *Cryst. Growth Des.*, **2019**, *19*, 1649–1659

# SYNTHESIS AND STRUCTURE OF CYCLOMETALATED IRIDIUM(III) COMPLEXES WITH HALOGEN-SUBSTITUTED 2-ARYLBENZIMIDAZOLES

*Koptyaeva A.G.*<sup>1,2</sup>, *Zakharov A. Yu.*<sup>2</sup>, *Bezzubov S.I.*<sup>2</sup>

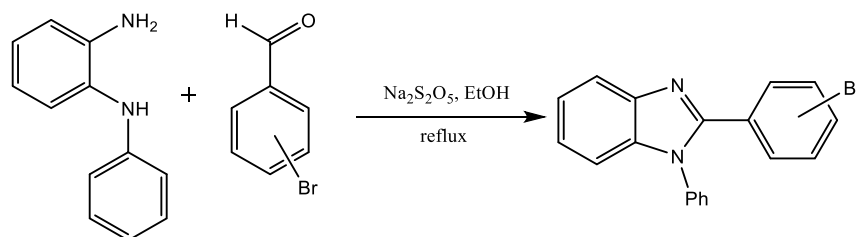
<sup>1</sup>D. Mendeleev University of Chemical Technology of Russia, Moscow, Russia

<sup>2</sup>Kurnakov Institute of General and Inorganic Chemistry of the Russian Academy of Sciences, Moscow, Russia  
Student

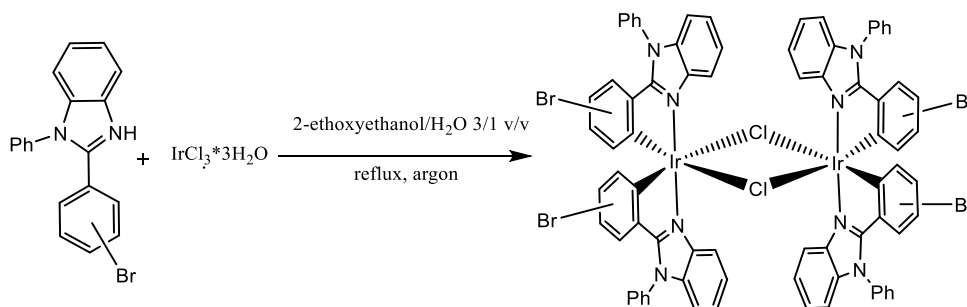
[anastasya31052000@gmail.com](mailto:anastasya31052000@gmail.com)

Cyclometalated complexes of iridium(III) can be used as dyes in solar cells, where they interact with an iodine-containing redox mediator. The study of these components in the liquid phase seems to be a difficult task while in the solid state, assuming the same nature of the charge transfer processes, it is rather easy to inspect these components by a powerful single-crystal X-ray analysis. For this purpose, cyclometalated iridium(III) complexes based on benzimidazole ligands containing halogen substituents combined with polyiodide anions of various architecture were selected.

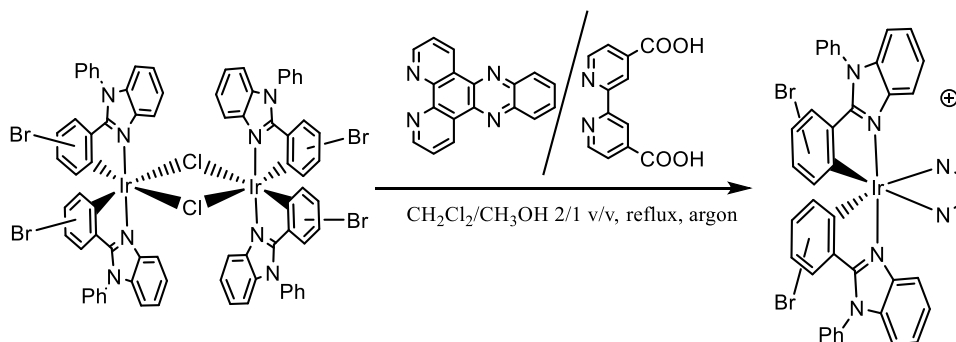
Experimental work was carried out in two steps. We synthesized bromo-substituted (in the *para*- and *meta*-positions) 2-arylbenzimidazoles (Scheme 1), 4,4'-dicarboxy-2,2'-bipyridine and dipyrido[3,2-a:2',3'-c]phenazine as ancillary N-donor ligands. A series of cyclometalated iridium(III)  $\mu$ -chloro-bridged dimers (Scheme 2) and cationic heteroleptic complexes was obtained (Scheme 3) and characterized by <sup>1</sup>H, <sup>13</sup>C NMR, high-resolution mass spectrometry and X-ray diffraction.



**Scheme 1.** Synthesis of 2-arylbenzimidazoles.



**Scheme 2.** Synthesis of dimeric chloride cyclometalated iridium(III) complexes.



**Scheme 3.** Synthesis of cationic heteroleptic iridium(III) complexes.

The cationic complexes were mixed with different iodine species and the resulting crystalline salts were studied by X-ray analysis and Raman spectroscopy.

LANTHANIDE COMPLEXES WITH 2-(TOSYLAMINO)-BENZYLIDENE-N-(ARYLOYL)-HYDRAZONES  
DESIGN FOR NIR OLEDs APPLICATION

*Koshelev D.S.*<sup>1</sup>, *Fedichkina A.D.*<sup>1</sup>, *Tcelykh L.O.*<sup>2</sup>, *Chikineva T.Yu*<sup>1</sup>, *Utochnikova V.V.*<sup>2</sup>

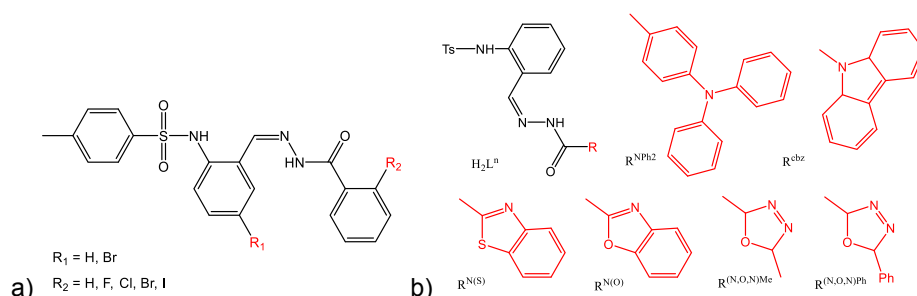
<sup>1</sup>Moscow State University, Faculty of Materials Science

<sup>2</sup>Moscow State University, Department of Chemistry

PhD student

[dan\\_kosh@mail.ru](mailto:dan_kosh@mail.ru)

Near-IR luminescence is currently attracting interest due to important technological applications in telecommunications and visualization. Ytterbium coordination compounds (CCs) are among the most promising NIR emitters because narrow emission bands. In our laboratory, it was found that the lanthanides CCs with 2-(tosylamino)-benzylidene-N-(aryloyl)-hydrazone demonstrate a high NIR luminescence QY (up to 1.4%), high absorption (up to 30000 (M·cm)<sup>-1</sup>), but low solubility, that results only in the one OLED emissive layer material demonstrated electroluminescent efficiency up to 50 μW/W [1-2]. To further optimize the properties of these compounds, we examined the effect of ligand halogenation on the solubility of these compounds (Fig.1a). Moreover, we studied the effect of the substitution by electron-donating and electron-acceptor fragments (Fig.1b) on the charge carrier mobility and, consequently, the OLED performance of the corresponding ytterbium with 2-(tosylamino)-benzylidene-N-(aryloyl)-hydrazones.



**Figure 1.** The structural formula of a) aryloyl-substituted b) halogen-substituted derivatives of 2-(tosylamino)-benzylidene-N-(aryloyl)-hydrazones (H<sub>2</sub>L<sup>R</sup>).

The synthesis of the lanthanides CC was carried out by the reaction.



The composition of the obtained compounds was determined from a combination of data from <sup>1</sup>H, <sup>13</sup>C NMR spectroscopy, IR spectroscopy, TGA, and elemental analysis.

The lanthanide CCs with aryloyl-substituted ligands, obtained by reaction (1), possess a lower solubility than is required for use in OLED (5 g/L). The potassium salts of the CCs were obtained by reaction (2). Some of them achieved the required solubility. To obtain a host-free emissive layer the heteroleptic CCs based on the one electron-acceptor and one electron-donating ligand were obtained by two methods: a) complex mixing or b) ligand mixing. The Yb and Lu complexes composition in the solution was investigated by 1D and 2D NMR spectroscopy showing the presence of the heteroleptic CC. Testing of ytterbium complexes in OLED shows that the highest efficiency up to 120 μW/W was measured for heteroleptic CC K[Yb(L<sup>NPh2</sup>)(L<sup>(N,O),N(Ph)</sup>)]. This electroluminescence spectrum at the same time demonstrates NIR emission for the most part.

All halogen-substituted CCs, even obtained by the reaction (1), possess high solubility in THF, acetonitrile, and DMSO. It was also shown that the solubility increases with an increase in the number of halogen-substituents and with a decrease in their atomic mass. Thus, Ln(Br<sup>2</sup>L<sup>F</sup>)(H<sup>Br</sup>L<sup>F</sup>) shows the greatest solubility (up to 21 g/L in THF). NIR luminescence shows that the CCs QYs reach up to 1.9%. Both of these properties make it easy to test ytterbium complexes in OLED, showing an efficiency up to 140 μW/W for Yb(Br<sup>2</sup>L<sup>H</sup>)(H<sup>Br</sup>L<sup>H</sup>).

## References

- [1] Utochnikova, V. V. et al.. *Dalt. Trans.* **2015**, *44*, 12660–12669  
[2] Kovalenko, A.D. et al. *Chem. Mater.* **2019**, *31*, 759–773

Acknowledgements. This work was supported by the Russian Science Foundation (project No 20-73-10053).

# SYNTHESIS OF THE COMPOSITIONS OF LAYERED GADOLINIUM-TERBIUM HYDROXIDES AND THE HYBRID LUMINOPHERS FORMED FROM THEM AND THE STUDY OF THEIR PROPERTIES

Kosykh A.S.<sup>1</sup>

<sup>1</sup>Ural Federal University, Yekaterinburg, Russia

PhD student

[kosykhastasiya@yandex.ru](mailto:kosykhastasiya@yandex.ru)

Layered hydroxides of rare earth elements (LRH) of the general formula  $\text{Ln}_2(\text{OH})_5\text{NO}_3 \cdot n\text{H}_2\text{O}$  are promising materials for the creation of luminescent materials [1]. The ability of these substances to intercalate makes it possible to synthesize hybrid materials with flexible optical properties when organic sensitizers of luminescence are introduced into the structure of LRHs [2]. The organic component intercalated into these compounds provides excellent optical functions, and the inorganic component provides stabilization, as well as thermal and radiation protection of the organic molecule. They can be used to create LEDs, photoluminescent pigments for paints, paper, plastics, etc. This work is devoted to the synthesis and study of the properties of a hybrid phosphor system based on layered Gd-Tb hydroxide nitrate using salicylate and terephthalate ions with different contents of  $\text{Tb}^{3+}$  as a sensitizer.

For the synthesis, aqueous solutions of gadolinium-terbium nitrate  $\text{Gd}_{1-x}\text{Tb}_x(\text{NO}_3)_3$  were prepared, where  $x = 0.01; 0.1; 0.5$  mol fraction, as well as 5 % ammonia  $\text{NH}_4\text{OH}$  used as a precipitant, the initial reaction volume of ammonium nitrate  $\text{NH}_4\text{NO}_3$  and sodium terephthal  $\text{C}_6\text{H}_4(\text{COONa})_2$  and salicylate  $\text{C}_6\text{H}_4(\text{OH})\text{COONa}$  used as sensitizers. The preparation of layered  $(\text{Gd}_{1-x}\text{Tb}_x)_2(\text{OH})_5\text{NO}_3 \cdot n\text{H}_2\text{O}$  (hereinafter GdTbx) was carried out as a result of the co-precipitation reaction by controlled double-jet precipitation (CDJP) at a constant pH of 8.0. The resulting precipitates were filtered, washed with water and alcohol, and air drying at room temperature and at 50 °C for 24 h, as described in our article [3]. Then, hydrothermal intercalation of salicylate ions was carried out at 120 °C for 12 h to obtain hybrid materials intercalated with terephthalate (GdTbxTA) and salicylate (GdTbxSA), followed by filtration and washing with water and alcohol, air drying at room temperature and at 150 and 40 °C for 24 h, respectively. The structure and optical properties of the resulting materials were studied using X-ray diffraction, optical microscopy, FT-IR and luminescence spectroscopy.

The structure of the GdTbx samples synthesized by the XRD method was identified in accordance with the results of other studies [3] as layered  $\text{Gd}_2(\text{OH})_5\text{NO}_3 \cdot n\text{H}_2\text{O}$ ; the study of the powders by FT-IR spectroscopy confirmed the results of X-ray phase analysis. XRD analysis and IR spectroscopy of the dried powders after intercalation indicate the successful introduction of organic guests into the interlayer space. Optical microscopy illustrates the formation of near-spherical particles that are not prone to change in shape or aggregation during drying.

The photoluminescence spectra of the hybrid materials GdTbxSA and GdTbxTA demonstrate their ability to absorb UV radiation with radiation in the visible spectrum. A characteristic feature of such a combination of a matrix-luminescent center as  $\text{Gd}^{3+}\text{-Tb}^{3+}$  is the presence of intense luminescence in the green region of the spectrum with a maximum at 540 nm. Comparison of the intensities of the photoluminescence spectra of hybrid and layered precursors makes it possible to draw a conclusion about the efficient transfer of energy from the sensitizer ions to the luminescent centers. It should be noted that the absorption wavelength ranges for hybrid phosphors are different: when the layered precursor is intercalated with  $\text{TA}^{2-}$  ions, absorption occurs in the range of 250-315 nm, while during intercalation with  $\text{SA}^-$  ions, this range is found to expand to 375 nm. The study of the dependence of the photoluminescence intensity on the terbium content  $x$  in the composition of the hybrid material also revealed differences due to the type of sensitizer. For the GdTbxTA system, it was found that the maximum intensity of the "green" radiation (excitation at  $\lambda_{\text{exc}} = 254$  nm, which corresponds to the highest UV absorption) is achieved at 10 mol %, however, the luminescence of the GdTbxSA system ( $\lambda_{\text{exc}} = 360$  nm) is most intense at a content of 1 % terbium.

## References

- [1] Gándara F., Perles J., Snejko N. *Angewandte Chem. – International Edition* **2006**, *45*, 7998–8001
- [2] Utochnikova V.V., Kuzmina N.P. *Russ. J. Coord. Chem.*, **2016**, *42*, 679
- [3] Mashkovtsev M.A., Kosykh A.S., Aleshin D.K., Gordeev E.V., Kuznetsova Y.A., Rychkov V.N., Zatsepin A.F. *Ceram. International* **2021**, *47*, 2725-2734

Acknowledgements. The author thanks of the Minobrnauki project FEUZ-2020-0059 for financial support.

POLYMETHINE DYE 2,2-DIFLUORO-4-(P-DIMETHYLAMINOSTYRYL)-6-PHENYL-1,3,2-DIOXABORINE AS A CATALYST AND MONOMER FOR BLOCK POLYMERIZATION OF METHYL METHACRYLATE

*Kozhemiakina E.K.*<sup>1</sup>, *Svistunova I.V.*<sup>1</sup>, *Fedorenko E.V.*<sup>2</sup>

<sup>1</sup>Far Eastern Federal University, Vladivostok, Russia

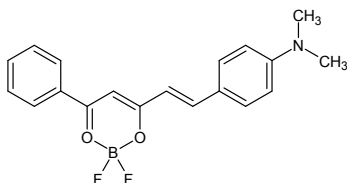
<sup>2</sup>Institute of Chemistry, Far Eastern Branch of the Russian Academy of Sciences, Vladivostok, Russia  
Student

[katerinachemistry1999@gmail.com](mailto:katerinachemistry1999@gmail.com)

$\beta$ -diketonates of boron difluoride attracted the attention of researchers in connection with the discovery of interesting properties that can facilitate their use in the production of functional materials: intense luminescence of solutions and crystals, large Stokes shift, the ability to form excimers and exciplexes, as well as size-dependent and mechanochromic properties [1]. The behavior of the phosphor in the polymer matrix differs from the behavior in the crystalline state and solutions due to various forms of aggregation. Therefore, it is of interest to study the luminescence of polymer composites with  $\beta$ -diketonates of boron difluoride.

Compounds for doping polymer composites can be polymethine dyes based on  $\beta$ -diketonates of boron difluoride, which can be used as photosensitizers in photography, fluorescent probes, polymerization initiators, active and passive components for tunable lasers and nonlinear optical materials [2].

The conditions for the interaction of methyl methacrylate (MMA) with 2,2-difluoro-4-(p-dimethylaminostyryl)-6-phenyl-1,3,2-dioxaborine (Figure 1) were selected and a procedure was developed for purifying the polymerization product from excess dye by transferring it into a water-soluble salt.



**Figure 1.** 2,2-difluoro-4-(p-dimethylaminostyryl)-6-phenyl-1,3,2-dioxaborine

In the course of the work, it was found that the 2,2-difluoro-4-(p-dimethylaminostyryl)-6-phenyl-1,3,2-dioxaborine complex has catalytic properties in the polymerization of methyl methacrylate. The polymerization time of methyl methacrylate with 7 mg (0.5%) benzoyl peroxide at 85 °C is 1.5 times longer than the polymerization time of the aforementioned compounds with 1 mg of the dye. Polymerization also takes place without adding other catalysts and initiators to the system, but the reaction rate is about 5 times lower than with the additional presence of benzoyl peroxide.

Luminescence spectroscopy revealed the presence of boron difluoride benzoylacetate fragments in the polymers, which proves the incorporation of the dye into the polymer chain. It is known that this polymethine dye is capable of cis-, trans- isomerization. The process goes through a triplet state in which the  $\pi$ -electrons of the double bond are not paired. This leads to the formation of a biradical, which is in the environment of methyl methacrylate. Possible processes can be associated with rotation around the C-C bond and pairing of electrons with the formation of the cis isomer, pairing of electrons with the formation of the trans-isomer, initiation of polymerization of methyl methacrylate with incorporation into the polymer chain.

In the time-resolved luminescence spectra of the reaction products at a low concentration of the dye (0.14%), the monomer and excimer luminescence of BAcBF<sub>2</sub> fragments prevails. With an increase in temperature to 90 °C and a high concentration (0.98%), a luminescence of an exciplex with a N, N-dimethylaniline fragment and a chelate cycle of BAcBF<sub>2</sub>. The intensity of monomeric luminescence decreases. The intensity of excimer luminescence at a temperature of 90 °C is equivalent to the intensity of exciplex luminescence. At a concentration of 0.98%, excimer luminescence predominates.

Thus, it can be concluded that 2,2-difluoro-4-(p-dimethylaminostyryl)-6-phenyl-1,3,2-dioxaborine is both a catalyst for the MMA polymerization reaction and one of the monomers. The resulting reaction products exhibit monomeric, excimer and exciplex luminescence.

### References

- [1] E. V. Fedorenko, A. G. Mirochnik, A. Yu. Beloliptsev. *J. Lumin.* **2017**. 185, 23-33.
- [2] E. V. Fedorenko, A. G. Mirochnik, A. Yu. Beloliptsev, V. V. Isakov. *Dyes Pigm.* **2014**, 109. 181-188

Acknowledgments. The work was supported by the Russian Foundation for Basic Research (project No 19-03-00409)

ISOSTRUCTURAL EXCHANGE IN ADDUCTS OF PALLADIUM(II)  
AND PLATINUM(II) IODIDE COMPLEXES WITH DIIODINE

*Kryukova M.A.*<sup>1</sup>, *Ivanov D.M.*<sup>1,2</sup>

<sup>1</sup> Institute of Chemistry, Saint Petersburg State University, Saint Petersburg 199034, Russia

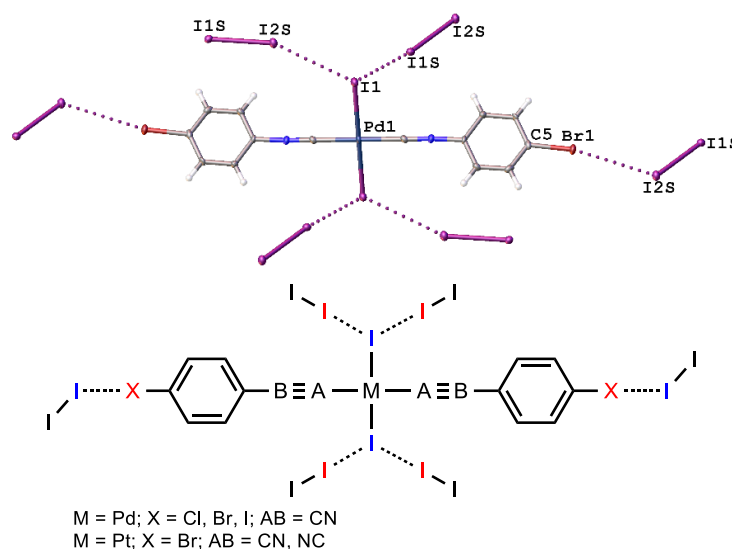
<sup>2</sup> Tomsk Polytechnic University, Tomsk 634034, Russia

PhD Student

[mary\\_kryukova@mail.ru](mailto:mary_kryukova@mail.ru)

A halogen bond (hereinafter XB) exists when there is evidence of attraction between an electrophilic region on a halogen atom in one molecular fragment and a nucleophilic region in another or the same molecular fragment, as defined by IUPAC [1]. Molecular iodine is a classical XB donor, and halide complexes of transition metals are actively studied XB acceptors.

The prediction of crystal structure is challenging problem, which may be solved by investigation of isostructural crystals demonstrating similar packing features and intermolecular interactions in them. In this work, a series of five isostructural cocrystals *trans*-[Ml<sub>2</sub>(ABC<sub>6</sub>H<sub>4</sub>-4-X)<sub>2</sub>]<sub>2</sub>I<sub>2</sub> (M = Pd; X = Cl, Br, I; AB = CN; M = Pt; X = Br; AB = CN, NC) were investigated by X-ray diffraction experiments following by theoretical calculations [2]. In the solids, the supramolecular aggregation is supported by the I–I⋯I–M and C–X⋯I–I XBs (Figure 1).



**Figure 1.** Environment of the *trans*-[PdI<sub>2</sub>(4-Br<sub>6</sub>H<sub>4</sub>NC)<sub>2</sub>]<sub>2</sub> complex molecule in adduct with I<sub>2</sub> (upper). Common scheme of the complex environment in the cocrystals (lower).

### References

- [1] G. R. Desiraju, P. S. Ho, L. Kloo, A. C. Legon, R. Marquardt, P. Metrangolo, P. Politzer, G. Resnati, K. Rissanen. *Pure Appl. Chem.* **2013**, *85*, 1711–1713.  
[2] Alexander V. Buldakov, Mikhail A. Kinzhalov, Mariya A. Kryukova, Daniil M. Ivanov, Alexander S. Novikov, Andrey S. Smirnov, Galina L. Starova, Nadezhda A. Bokach and Vadim Yu. Kukushkin. *Crystal Growth Des.* **2020**, *20*, 1975–1984.

**Acknowledgements.** The proposed research was supported by The Ministry of Science and High Education of Russian Federation in frame of 220PP project (number 2020-220-08-8827). Theoretical studies were funded by the Russian Foundation for Basic Research (Project No. 18-29-04006).



INVESTIGATION OF THE CATALYTIC PROPERTIES OF OCTASUBSTITUTED COBALT  
PHTHALOCYANINES CONTAINING 2-CARBOXYPHENYLSULFO-  
AND 3-CARBOXYPHENYLSULFO-GROUPS

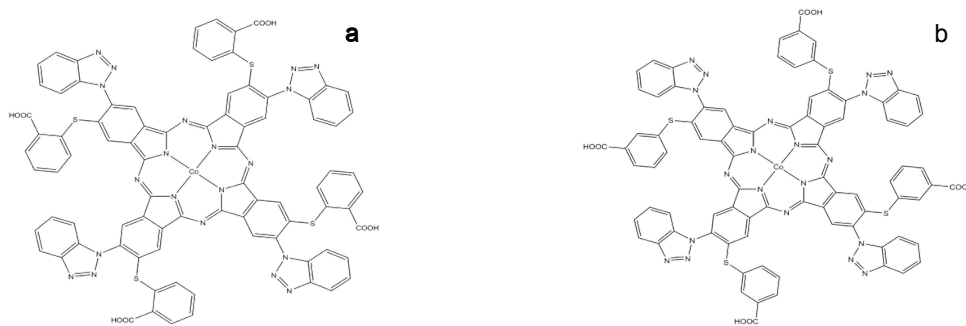
*Kulik D.S.<sup>1</sup>, Mozhaev S.K.<sup>1</sup>, Erzunov D.A.<sup>1</sup>, Vashurin A.S.<sup>1</sup>*

<sup>1</sup>Ivanovo State University of Chemistry and Technology, Ivanovo, Sheremetevsky Avenue, 7  
Student

[Kulik\\_dima@inbox.ru](mailto:Kulik_dima@inbox.ru)

Metallophthalocyanines (MPc), being thermally stable, readily available and cost-effective, are extremely attractive for use as catalysts[1]. For example, the oxidation of thiols by oxygen, catalyzed by cobalt phthalocyanine complexes, received considerable attention[2]. Phthalocyanine-based catalysts are used to remove mercaptans from oil fractions and alkali sulfides from wastewater.

The aim of this work is to study and compare the catalytic activity of a number of octosubstituted carboxylic acids of cobalt phthalocyanine (Fig.1) with different positions of the carboxyl group.



**Figure 1.** Research objects:

- a - tetra-4 - (2-carboxyphenylsulfo)- tetra-5-benzotriazole-cobalt phthalocyanine
- b - tetra-4 - (3-carboxyphenylsulfo)- tetra-5-benzotriazole-cobalt phthalocyanine

The catalytic properties were studied on the example of the oxidation reaction of 2-mercaptoethanol.

For the experiment, a solution of 2-mercaptoethanol (2-ME) was taken, as well as a solution of copper salt with a high concentration. The reaction was carried out by blowing oxygen from the air.

During the reaction, samples of 1 ml were taken and placed in a solution of copper sulfate. Immediately after this, the oxidation product (disulfide) was separated using dichloromethane. The electronic absorption spectra of each sample were then taken.

The relations of changes of the catalytic activity of phthalocyanines when replacing the 2-carboxyphenylsulfo group with the 3-carboxyphenylsulfo group are given.

#### References

- [1] Sharma R. K., Gulati S., Pandey A. *Inorg. Chim. Acta*, **2013**, 397, 21–31.
- [2] Iliev V.I., Ilieva A.I., Dimitrov L.D. *Appl. Catal. A, Gen. Elsevier*, **1995**, 126, 2, 333–340.

Acknowledgements. This work was supported by the Russian Science Foundation (project No 17-73-20017)

SOLVENT-FREE DEHYDROCOUPLING OF PHENYLSILANES AND ALCOHOLS:  
KINETIC AND MECHANISTIC STUDY

*Kulikova V.A.*<sup>1,2</sup>, *Kirkina V.A.*<sup>1</sup>, *Voronova E.D.*<sup>1</sup>, *Filippov O.A.*<sup>1</sup>, *Belkova N.V.*<sup>1</sup>, *Shubina E.S.*<sup>1</sup>

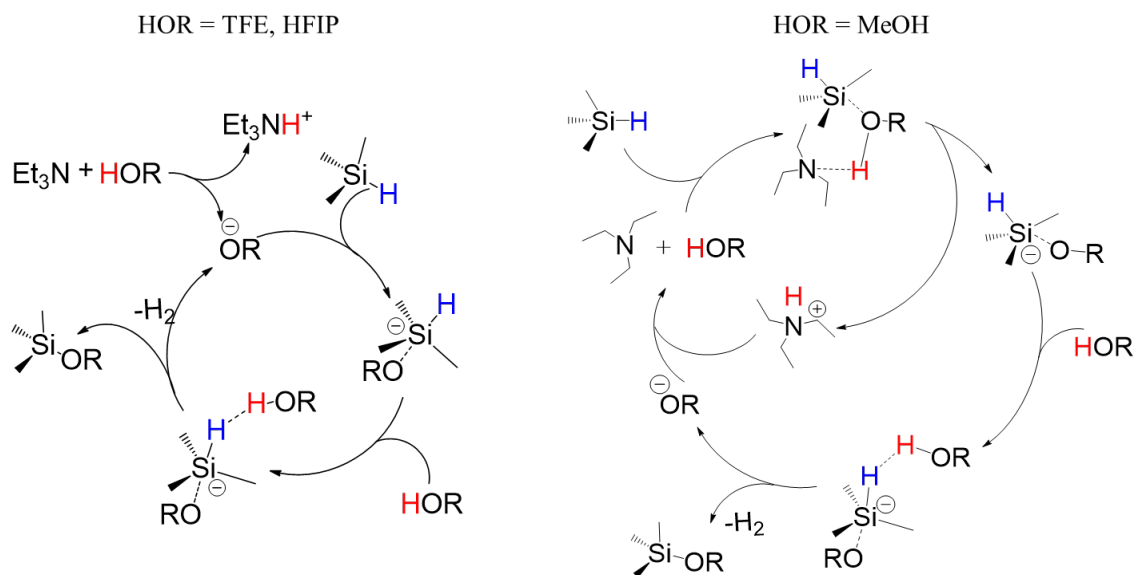
<sup>1</sup> A.N. Nesmeyanov Institute of Organoelement Compounds, Russian Academy of Sciences, Moscow, Russia

<sup>2</sup> Moscow State University, Moscow, Russia

Student

[kullisa99@gmail.com](mailto:kullisa99@gmail.com)

Main group E-H bond activation is one of the topical issues of modern organoelement chemistry. Dehydrocoupling of silanes and alcohols in the presence of a basic catalyst is an important method of alkoxy silane synthesis [1-3]. Dehydrocoupling of phenylsilanes and hexafluoroisopropanol in the presence of Et<sub>3</sub>N has been studied in low polar solvents [4-5], however such reaction in solvent-free system is also of great interest. In this work we present recent kinetic and mechanistic studies of the solvent-free dehydrocoupling of silanes (Ph<sub>2</sub>SiH<sub>2</sub>, PhSiH<sub>3</sub>, PhMeSiH<sub>2</sub>) and various alcohols (MeOH, CF<sub>3</sub>CH<sub>2</sub>OH (TFE), (CF<sub>3</sub>)<sub>2</sub>CHOH (HFIP)) in the presence of NEt<sub>3</sub>. Depending on the alcohol acidity different mechanisms of the reaction have been proposed (Figure 1): less acidic MeOH is not able to be deprotonated by Et<sub>3</sub>N to form a real catalyst – alkoxide-anion, so trimolecular noncovalent complex silane-MeOH-Et<sub>3</sub>N should be generated first (Figure 1, right). Variable temperature kinetic studies have shown different temperature behavior for the reaction rate constant in the case of TFE and MeOH, which supports the mechanisms proposed.



**Figure 1.** Proposed mechanism of base-catalyzed dehydrocoupling of silanes and alcohols of high (*left*) and low (*right*) acidity.

**References**

- [1] Eaborn C., Jenkins I. D. *J. Organomet. Chem.* **1974**, 69 (2), 185–192  
 [2] Weickgenannt A., Oestreich M. *Chem. Asian J.* **2009**, 4 (3), 406–410  
 [3] Toutov A. A., Betz K. N., Haibach M. C., Romine A. M., Grubbs R. *Org. Lett.* **2016**, 18 (22), 5776–5779  
 [4] Voronova E. D., Golub I. E., Pavlov A., Belkova N. V., Filippov O. A., Epstein L. M., Shubina E. S. *Chem. Asian J.* **2018**, 13 (20), 3084–3089  
 [5] Voronova E. D., Golub I. E., Pavlov A., Belkova N. V., Filippov O. A., Epstein L. M., Shubina E. S. *Inorg. Chem.* **2020**, 59 (17), 12240–12251

Acknowledgments. This work was supported by the Russian Foundation for Basic Research (project No 19-03-00524).

*Kurapova O.Yu.<sup>1</sup>, Zaripov A. A.<sup>1</sup>, Pazheltsev V. V.<sup>1</sup>, Glumov O.V.<sup>1</sup>, Faia P.M.<sup>2</sup>*

<sup>1</sup>Saint Petersburg State University, Saint Petersburg, Russia

<sup>2</sup>University of Coimbra, Coimbra, Portugal.

Associate Professor

[o.y.kurapova@spbu.ru](mailto:o.y.kurapova@spbu.ru)

The development of the scientific basics for the novel membrane materials manufacturing for electrochemical power units i.e. low temperature fuel cells (FC) efficiently working up to 300 °C is a serious scientific problem related to hydrogen energy shift. Polyantimonic acid (PAA) is characterized by high conductivity and thermal stability can be regarded as a prospective proton conducting material. So the goal of the current work was the investigation of the structure, phase stability, and protonic conductivity of PAA based solid electrolytes.

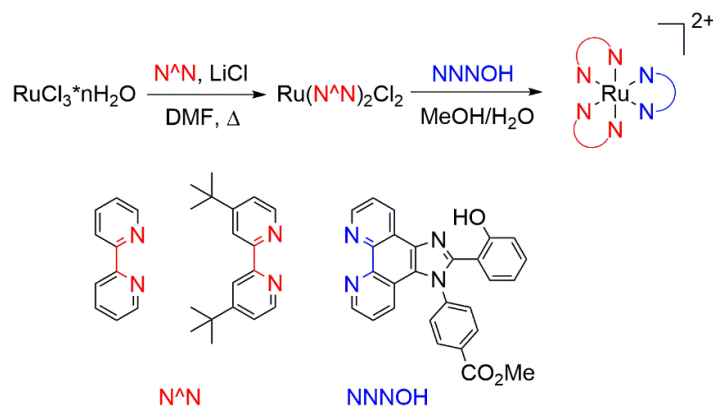
PAA was synthesized using the controlled hydrolysis of  $\text{SbCl}_5$  in the tenfold excess of water. Then the precipitate was treated by 1n HCl and again washed with distilled water until the negative reaction to chlorine ions. Then using 10 and 20 wt.% of fluoroplastic as a binder the cylindrical solid electrolytes (SE) of 30 mm in diameter and 5 mm in thickness were formed by cold uniaxial pressing. Structure of the formed membranes was investigated by thermo-XRD (SHIMADZU XRD-6000), SEM and EDX (Hitachi S-3400N) techniques, STA technique, Raman spectroscopy and hydrostatic weighting. The conductivity of SE in the range 60-300 °C was investigated by electrochemical impedance study in the dry nitrogen, room air and presence of humidity.

Using STA and XRD it was shown that the structure of SE correspond to crystalline  $\text{Sb}_2\text{O}_5 \times 3\text{H}_2\text{O}$ . STA, Raman spectroscopy and thermo-XRD showed that the temperature increase results unit cell shrinkage and crystallinity decrease from ~91 to 75% because of step by step water removal. According hydrostatic weighting, SEM and EDX data, fully dense membranes were obtained, where a binder do not cover PAA grains enabling the ion transport through the grain bulk. Via impedance spectroscopy it was shown that PAA is a great protonic conductor in a presence of moisture. The temperature dependence of conductivity of PAA is complex due to prolonged water losses and the increase of carrier charge mobility with temperature increase.

Acknowledgements. This work was supported by the President's grant for young scientists (research project 75-15-2021-370). SEM and EDX data were obtained at «GEOMODEL» center, thermo-XRD data were performed at the Center for X-ray Diffraction Studies and Raman Spectroscopy data were obtained in «Center for Optical and Laser Research» of SPBU Research park.

Temperature is a key parameter in many fields of the research area. Luminescence-based temperature sensing is a solution for those applications in which traditional (mechanical, electrical, or IR-based) thermometers struggle [1]. Amongst luminescence thermometers, ruthenium(II) complexes are undoubtedly leaders in terms of compilation of factors such as sensitivity, chemical inertia, and high values of the lifetime of the excited state [2-3]. One of the most important advantages of such complexes is their emission in the red region of the spectrum. It is preferable for bioimaging purposes since the emission will pass with less absorption through the living tissues [4].

Despite the high sensitivity of these complexes to temperature, the limitation for them is the simultaneous sensitivity to molecular oxygen. This sensitivity is explained by the phenomenon of triplet-triplet annihilation of the excited state with triplet oxygen. Earlier it was shown that the contribution of dynamic quenching can be reduced, for example, by placing the phosphor in a polymeric shell [1,2]. In this work, branched tert-butyl fragments were added to the structure for these purposes. Simultaneously, the introduction of donor fragments should lead to an increase in the sensitivity of the phosphor to temperature due to an increase with the accessibility of the  $^3MC$  excited state [2,5].



**Figure 1.** Scheme of synthesis of obtained compounds.

Thus, the purpose of this research was to obtain and characterize ruthenium(II) complexes using NMR and mass spectrometry methods. The absorption, emission, excitation spectra were carefully measured, as well as the dependence of the lifetimes on the temperature in the solution.

### References

- [1] Miranda M., Levi V., Wolosiuk A., etc. *Journal of Colloid and Interface Science* **2013**, 392, 96–101
- [2] Bustamante N., Ielasi G., Orellana, G., etc. *Polymers* **2018**, 10(3), 234
- [3] Wang X., Wolfbeis O.S., Meier, R.J. *Chemical Society Reviews* **2013**, 42(19), 7834
- [4] Zhen X., Qu R., Jiang X. *Biomaterials Science* **2021**, 9, 285-300
- [5] Van Houten, J., & Watts, R. J. *Journal of the American Chemical Society* **1976**, 98(16), 4853–4858

Acknowledgements. This work was supported by the Russian Science Foundation (project No 19-13-00132).

# SYNTHESIS AND THE PROPERTIES OF BOROSILICATE GLASS WITH INCREASED CONTENTION OF STRONTIUM OXIDES AND CESIUM

*Kuznetsova A.A.<sup>1</sup>; Turnina S.G.<sup>1</sup>; Turnina N.G.<sup>1</sup>; Polyakova I.G.<sup>1</sup>,  
Karpovich N.F.<sup>2</sup>, Slastikhina P.V.<sup>2</sup>*

<sup>1</sup>Institute of Chemistry of Silicates by I.V. Grebenshchikov, RAS,

<sup>2</sup>V.G. Khlopin Radiation Institute, St. Petersburg, Russia

[turnina.ng@iscras.ru](mailto:turnina.ng@iscras.ru)

Developments in the management of high-activity waste (HAW) show that approaches to the release of a number of long-lived radionuclides from the total mass of waste have significant benefits. The cost of final disposal of waste under this approach can be reduced by 50-60%. Given that caesium and strontium are secreted in the form of pure concentrates, studies aimed at developing the composition of borosilicate glass with an increased content of these radionuclides are very relevant.

The aim of the work is to obtain and investigate the properties of borosilicate glasses with high inclusion of SrO and/or CsO and to assess their compliance with safety requirements.

As part of the work, 10 compositions of glass were synthesized on the basis of borosilicate matrix, which includes: B<sub>2</sub>O<sub>3</sub>, Li<sub>2</sub>O, Na<sub>2</sub>O, Al<sub>2</sub>O<sub>3</sub>, SiO<sub>2</sub>, CaO, MnO<sub>2</sub> and SrO and/or Cs<sub>2</sub>O with 10 to 30 mass.%. Synthesis temperature - 1100-1150 °C, isothermic aging time - 1.5-2 hours, with further aging of glass at a temperature of 420 °C, for 2 hours synthesized glass studied by methods of x-ray analysis (XRA), electron microscopy (SEM), X-ray spectral microanalysis (RSMA), differential thermal analysis (DTA). The method of hydrostatic weighing determines the density of glass, calculated molar volume.

According to the results of the XRA, all synthesized glasses are X-ray, and according to SEM and RSMA - homogeneous, the estimated compositions of the glass correspond to the compositions of the analysis.

It is shown that with the increase in the content of SrO and/or Cs<sub>2</sub>O, the density of the glass increases linearly. The most dense are samples containing SrO, the smallest - Cs<sub>2</sub>O.

It has been established that when the SrO content in the glass increases, the molar volume practically does not change, which indicates that the packaging of the glass mesh with the increase in the content of SrO practically does not change.

Analysis of the data of the DTA (with linear heating up to 1000 °C) showed that the glass temperature of all samples is in the area of temperatures 450-500 °C.

To determine crystallization resistance, samples were subjected to isothermic aging for 200 hours at 550 degrees Celsius. % of SrO and/or Cs<sub>2</sub>O after exposure, according to the results of the RFA, remained X-ray, and samples of glass with 30 masses. % of inclusions crystallized with the formation of phases SrSiO<sub>3</sub>, CsAlSiO<sub>4</sub> and CsBSi<sub>2</sub>O<sub>6</sub>.

The chemical resistance was assessed by the express method (T = 100 °C, 5 hours). Was found to be a loss of mass, samples containing 10 and 20 masses. % SrO and 10 masses. % Cs<sub>2</sub>O ≈ 0.2%, the largest loss of the mass of glass containing 30 masses. Cs<sub>2</sub>O is 0.47%.

As a result of the work it is shown that borosilicate glass containing 10 and 20 masses. % SrO and 10 masses. % of Cs<sub>2</sub>O is homogeneous, high in thermal, crystallization and waterproof and meet safety requirements.

Glass containing 10 and 20 masses. The amount of SrO and Cs<sub>2</sub>O have a high crystallization stability, but when tested for water resistance, the value of their mass loss is ≈ 0.4 masses. % all samples of borosilicate glasses with the inclusion of 30 masses. % of the research does not meet the safety requirements of the HAW burial.

## References

- [1] Feasibility of Separation and Utilization of Cesium and Strontium from High Level Liquid Waste. Technical Report Ser. N 356. Vienna: IAEA, 1993.
- [2] Ala A.S., Trofimenko A.V., Ishakova O.A., Kolicheva T.I. Development of the composition of the matrix for glazing concentrate strontium and caesium from highly active waste / Radiochemism. 1997. T. 39. № 6. S. 562 - 568.
- [3] Federal regulations and regulations on the use of nuclear energy "The collection, processing, storage and conditioning of liquid radioactive waste. Safety requirements" (NP-019-15). Moscow: Federal Service for Environmental, Technological and Atomic Oversight, 2015.

# NITROGEN AND PHOSPHORUS RECYCLING IN COMPLEX PROCESSING OF HIGHLY CONCENTRATED SALT SOLUTIONS, BY PRECIPITATION OF AMMONIUM AND PHOSPHATE IONS IN THE FORM OF STRUVITE

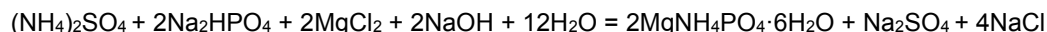
*Kuznetsova Yu.V.<sup>1</sup>, Volkhin V.V.<sup>1</sup>, Poylov V.Z.<sup>1</sup>, Permyakova I.A.<sup>1</sup>.*

<sup>1</sup>Perm national research polytechnic university, Perm, Russia  
Graduate student  
[julietta44perm@mail.ru](mailto:julietta44perm@mail.ru)

Processing of salt runoff from the catalyst production of Gazpromneft-Omsk JSC with the production of various commercial products meets the requirements of the global trend for the transition to a closed-cycle economy. Salt solutions contain a mixture of mainly sodium sulfate and ammonium. One of the solutions for the purification of salt effluents from ammonium ions is struvite [1]. The process of struvite deposition from highly concentrated mixed salt solutions is poorly understood and has become the subject of research in this scientific work.

The study was performed using the scientific equipment of the Central Research Center "High-Tech Chemical Technologies and Physico-Chemical Research" of PNRPU using the inductively coupled plasma method (ICAP 6500 Duo spectrometer, Thermo, USA, with iTEVA software), X-ray phase analysis (XRD-7000, Shimadzu, Japan, with XRD 6000/7000 Ver software.5.21 and the JCPDSPDFI database), IR-Fourier spectroscopy (Nicolet 380, Thermo, USA).

In the complex processing of salt runoff, the struvite deposition process is carried out before the conversion of the salt solution. Struvite synthesis proceeds according to the reaction equation



A solution having the composition was used, % mass:  $(NH_4)_2SO_4$  – 2.19;  $Na_2SO_4$  – 3.79;  $NH_4NO_3$  – 0.25;  $NaNO_3$  – 2.21;  $H_2O$  – other. In accordance with the composition of struvite, its precipitation was carried out by mixing equimolar Mg, N, and P amounts of salt solution (without dilution) and reagents:  $MgNH_4PO_4 \cdot 6H_2O$  for magnesium and  $Na_2HPO_4$  for phosphate, the pH value was regulated by NaOH solution. The conditions favorable for the synthesis of struvite are established: when mixing reagent solutions, the required amount of  $Mg^{2+}$  ions is recommended to be introduced into the initial salt solution, and a  $Na_2HPO_4$  solution containing the amount of NaOH necessary to achieve the specified pH value is poured into it with intensive mixing. The maximum saturation of struvite with  $NH_4^+$  ions was achieved at pH 9.2-9.8, but similar results were obtained at pH 8.5 – 9.2, the mixing time of the reagents was 0.7-1.0 m with intensive mixing, and the duration of sediment retention in the mother cell was up to 10 minutes. Struvite precipitate, washed from the soluble reaction products with water at the water ratio/the precipitate 0.2 (under centrifugation conditions) contains practically no impurities of sodium and potassium salts.

In order to improve the economic performance of the process, the problems of replacing expensive  $MgCl_2 \cdot 6H_2O$  salts with enriched carnallite  $KClMgCl_2 \cdot 6H_2O$  and  $Na_2HPO_4$  with a product of neutralization of technical phosphoric acid (73%  $H_3PO_4$ ), technical crystalline soda ash (99%  $Na_2CO_3$ ) with blowing off the released  $CO_2$  were solved. The replacement of reagents did not lead to a decrease in the quality of the resulting struvite.

Struvite is a long-acting fertilizer, and has a number of corresponding advantages over traditional fertilizers [2]. According to [1], struvite is recommended to be used as a complex NPMg-fertilizer after its granulation with the use of a 10% aqueous solution of sodium metasilicate as a binder.

## References

- [1] Patent RU 2 716 048 C1, IPC C01D 5/06 (2006.01)C05D 1/00 (2006.01) C05D 5/00 (2006.01) C05G 3/00 (2006.01) C01D 9/08 (2006.01), Method for processing waste of salt solutions containing a mixture of ammonium and sodium sulfates and nitrates, Melekhin A. A., Poylov V. Z. and others, Gazpromneft - Omsk Refinery Joint Stock Company (RU), 16.09.2019.
- [2] M.M. Rahman, M.A.M. Salleh, U. Rashid et al. Production of slow release crystal fertilizer from wastewaters through struvite crystallization – A review. *Arab. J Chem.* **2014**, 7, 139–155

CALCIUM, YTTERBIUM(II) AND SAMARIUM(II) BIS(AMIDO) COMPLEXES COORDINATED BY NHC LIGANDS – VERSATILE CATALYSTS FOR HYDROPHOSPHINATIONS WITH PH<sub>3</sub>

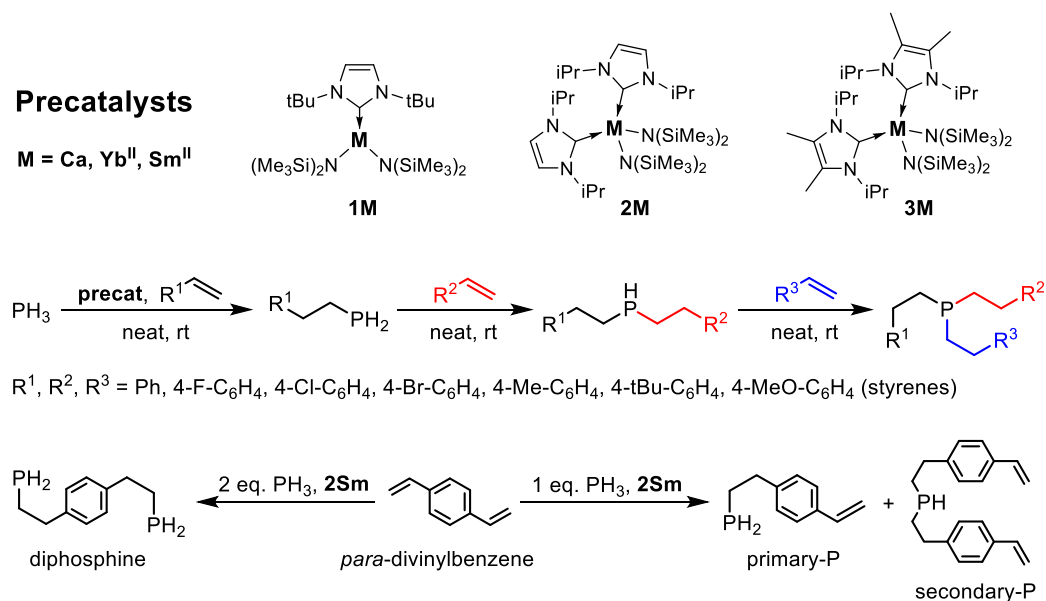
Lapshin I.V.<sup>1</sup>, Trifonov A.A.<sup>1,2</sup>

<sup>1</sup>G. A. Razuvaev Institute of Organometallic Chemistry of Russian Academy of Sciences, Nizhny Novgorod, Russia

<sup>2</sup>A. N. Nesmeyanov Institute of Organoelement Compounds of Russian Academy of Sciences, Moscow, Russia  
PhD student  
[student.unn@gmail.com](mailto:student.unn@gmail.com)

1. The creation of C–P bonds via intermolecular hydrophosphination reactions of unsaturated substrates is a promising, atom-efficient route to a number of valuable phosphorus-containing compounds. Despite the progress achieved in this field, the substrate scope remains limited and predominantly involves activated olefins and ubiquitous phenyl- and diphenylphosphine. Addition of PH<sub>3</sub> to alkenes and alkynes is a simple and convenient synthetic route to a variety of primary, secondary and tertiary phosphines.

2. The first example of intermolecular hydrophosphination of *para*-substituted styrenes, 2-vinylpyridine and phenylacetylene with PH<sub>3</sub> catalyzed by metal-NHC adducts [(Me<sub>3</sub>Si)<sub>2</sub>N]<sub>2</sub>M(NHC)<sub>n</sub> is described. The reactions of styrene with PH<sub>3</sub> proceed under mild conditions in close-to-quantitative yields to afford exclusively anti-Markovnikov product and allow for the chemoselective synthesis of primary, secondary and tertiary phosphines. The possibility of chemoselective sequential alkylation of phosphine with various *para*-substituted styrenes has been demonstrated, and a number of new asymmetric secondary and tertiary phosphines were obtained and characterized (Figure 1).



**Figure 1.** Reaction scope for alkylation of PH<sub>3</sub> catalyzed by NHC-M-amido complexes (M = Ca, Yb(II), Sm(II)).

3.

4. The use of polyfunctional alkene substrates such as *para*-divinylbenzene allowed to synthesize a series of new phosphine products (1,4-bis(2-phosphinoethyl)benzene, 4-vinylphenylethylphosphine and bis(4-vinylphenylethyl)phosphine). Taking advantage of the high chemoselectivity of the addition of phosphine to double bonds, the formation of desired reaction products can be achieved by varying the initial ratio of the reagents. The Lewis base coordinated to the metal center (NHC vs. THF) had crucial effect on catalytic activity in styrene hydrophosphination with PH<sub>3</sub> [1–2].

5.

#### References

- [1] Lapshin I.V., Basalov I.V., Lyssenko K.A., Cherkasov A.V., Trifonov A.A. *Chem. Eur. J.* **2019**, *25*, 459- 463  
[2] Lapshin I.V., Cherkasov A.V., Asachenko A.F., Trifonov A. A. *Chem. Commun.*, **2020**, *56*, 12913-12916

Acknowledgements. This work was supported by the Russian Science Foundation (project No 17-73-20262-П).

Larionova K.A.<sup>1</sup><sup>1</sup>Tyumen Industrial University, Tyumen, Russia

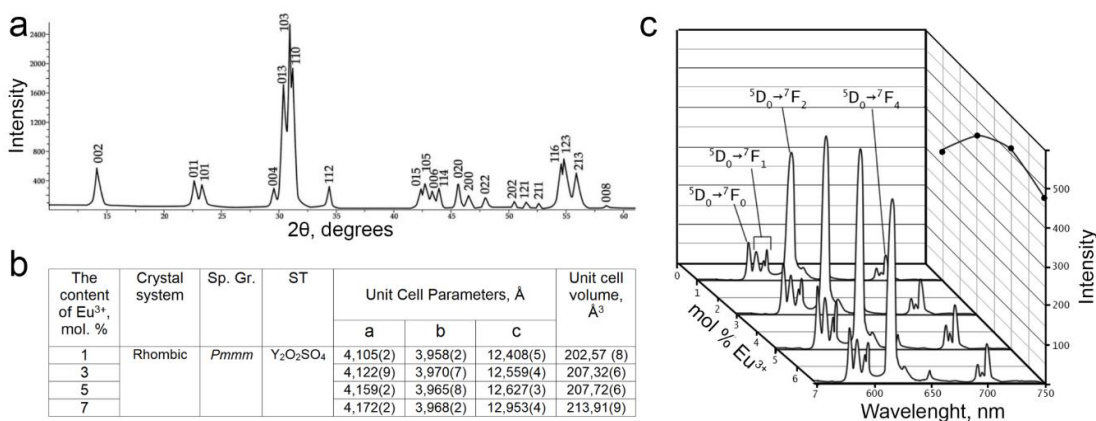
Young Scientist

[loakaon@gmail.com](mailto:loakaon@gmail.com)

Medical imaging technology is widely used both in medical diagnostics and in disease monitoring, surgical interventions and research. The development of contrast agents that can be determined by two or more imaging methods is of great interest. The possibility of using Lu<sub>2</sub>O<sub>2</sub>SO<sub>4</sub>:Ln<sup>3+</sup> compounds as multifunctional contrast agents for medical imaging was indicated in [1].

In this work, we investigated the possibility of creating a series of solid solutions of Lu<sub>2</sub>O<sub>2</sub>SO<sub>4</sub>:Eu<sup>3+</sup> (1.3.5.7 mol%) by coprecipitation method, studied the morphology of powder particles and their optical properties. The synthesis was carried out according to the procedure described in [2].

To determine the phase composition of the samples, we used a BRUKER D2 PHASER X-ray diffractometer with a linear detector LYNXEYE (CuK $\alpha$  radiation, Ni-filter). The crystal structure was refined using the Rietveld method in the TOPAS 4.2 program. The structure studies show that the parameters and the unit cell volume of the compound increase monotonously with increasing Eu<sup>3+</sup> ion content, which indicates the formation of a continuous series of substitutional solid solutions in the indicated concentration range (Fig. 1 b).



**Figure 1.** XRD pattern (a), crystal parameters (b) and emission spectra (c) of Lu<sub>2</sub>O<sub>2</sub>SO<sub>4</sub>:Eu<sup>3+</sup> samples

During the research we also find out that the size and shape of the obtained particles are very related to synthesis time. At the minimum synthesis time we obtained spherical particles with average size between 300 and 350 nm, and the particle size distribution is close to the normal (Gaussian) distribution. With increasing synthesis time, the average particle size increases, and their size distribution becomes more heterogeneous.

Doping with Eu<sup>3+</sup> ions allows the compound to show very strong luminescence in the red region. Luminescent spectroscopy was performed on a Fluorolog-3 spectrofluorimeter (Horiba Jobin Yvon). The study of the luminescent properties of a number of samples upon excitation of light at 270 nm showed that strong peaks in the regions of 610-620 and 690-710 nm are present in the emission spectra of the samples (Fig. 1 c).

The study of X-ray contrast properties was carried out on a YXLON MU2000-D industrial computer tomograph with a radiation power of 100 kV. During this study it was clarified that the test substance has the ability to absorb x-ray radiation.

### References

- [1] Osseni, S. A. et al. *J. Nanostruct. Chem.* **2017**, 7, 337–343  
 [2] Osseni, S. A. et al. *J. Mater. Chem.* **2011**, 21, 18365–18372



# CYCLOMETALATED RUTHENIUM (II) COMPLEXES WITH 2-ARYL-1,3-AZOLES: SYNTHESIS, OPTICAL AND ELECTROCHEMICAL PROPERTIES

Lavrova M.A.<sup>1</sup>, Mishurinskiy S.A.<sup>1</sup>, Savchenko A.G.<sup>1</sup>, Bezzubov S.I.<sup>2</sup>, Dolzhenko V.D.<sup>1</sup>

<sup>1</sup> Moscow State University, Moscow, Russia

<sup>2</sup> Kurnakov Institute of General and Inorganic Chemistry, Moscow, Russia

PhD student

[maryapril05@mail.ru](mailto:maryapril05@mail.ru)

Ruthenium (II) polypyridine complexes are used as sensitizers in DSSC (Dye Sensitized Solar Cell). In solar cells, dye molecules adsorbed on the surface of a wide-gap semiconductor absorb electromagnetic radiation, become excited, and an electron is transferred to the conduction band of the semiconductor. There are two types of ligands in the structure of the complex: "donor" ligands, which are responsible for the absorption of light, and a ligand with "anchor" groups (for example, with carboxyl, phosphoryl, or sulfone groups), with the help of which covalent bonding to the semiconductor surface occurs. Ruthenium complexes absorb well solar radiation in the visible and near-IR ranges and have suitable redox potentials for cell operation. However, they do not have good stability, which reduces the cell life. The introduction of a cyclometallated fragment (a five-membered ring with a covalent metal-carbon bond) into the complex increases the stability of the complexes.

Nevertheless, with an increase in the stability of the complexes, their optical and electrochemical properties deteriorate. Therefore, the efficiency of thiocyanate complexes has not yet been achieved for cyclometallated ones. To fine-tune the properties of the complexes, we propose various methods for modifying the donor ligand, such as changing the substituents in the aryl and benzimidazole fragments, expanding the conjugated system, and changing heteroatoms.

In this work we introduce Ru (II) complexes with various 2-aryl-1,3-azoles and dimethyl ester of 4,4'-dicarboxy-2,2'-bipyridine (dmdcbp) with a general formula  $Ru(L)(dmdcbp)_2PF_6$ . All the complexes are characterized by NMR, UV-vis and luminescence spectroscopy, and cyclic voltammetry (CV), for some complexes crystals for X-ray structural analysis are obtained. Several complexes are mildly hydrolyzed and tested in a solar cell. It is shown that the obtained complexes are suitable for operation in a cell. The efficiency obtained depends non-monotonically on the donor properties of the substituents.

## References

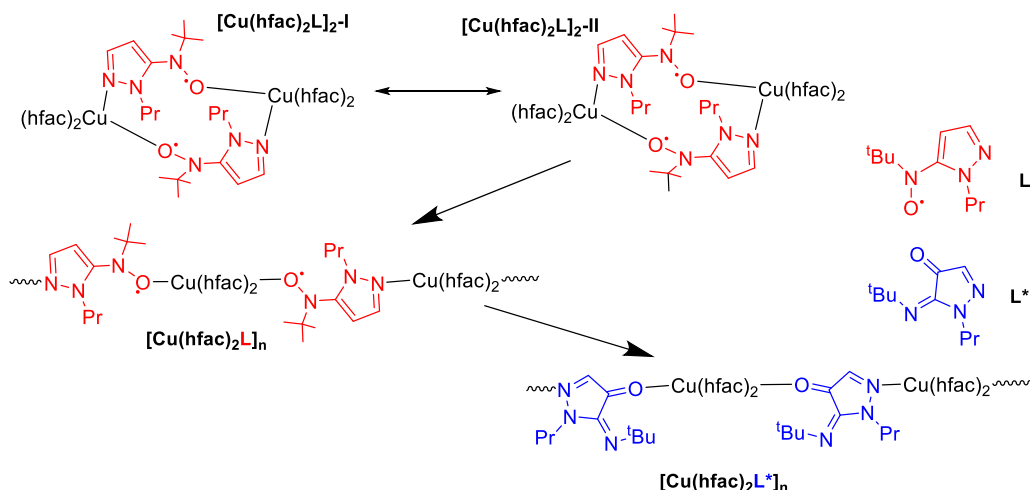
[1] Lavrova M. A., Mishurinskiy, S. A., Smirnov, D. E., Kalle, P., Krivogina, E. V., Kozyukhin, S. A., ... & Bezzubov, S. I. *Dalton Trans.* **2020**, 49(46), 16935-16945.

Acknowledgements. This work was supported by the Russian Science Foundation (project No 19-73-00351).

Heterospin solids based on Cu(II) complexes with stable nitroxides are known to demonstrate reversible magnetostructural phase transitions upon various external stimuli (temperature, pressure or light) [1-3]. Due to this reason, they potentially could be utilized as spin-sensors or switches. Phase transitions are provoked by the transformations of the Cu(II) environment, resulting in the anomalies of the magnetic properties. We present unusual transformations in the solid state of heterospin Cu(II) hexafluoroacetylacetonone (Cu(hfac)<sub>2</sub>) complexes with pyrazolyl-substituted *tert*-butyl-nitroxide (L), accompanied by bond breaking.

The procedure for the synthesis of molecular complexes [Cu(hfac)<sub>2</sub>L]<sub>2</sub> and polymeric chain [Cu(hfac)<sub>2</sub>L]<sub>∞</sub> is described elsewhere [4]. [Cu(hfac)<sub>2</sub>L]<sub>2</sub> could form two polymorphic modifications ([Cu(hfac)<sub>2</sub>L]<sub>2</sub>-I and [Cu(hfac)<sub>2</sub>L]<sub>2</sub>-II). These modifications differ by packing of nearly identical centrosymmetric cyclic binuclear molecules formed as the result of nitroxide bridging function. [Cu(hfac)<sub>2</sub>L]<sub>2</sub>-I crystals are stable below 257 K, and at room temperature (~293 K) they demonstrate chemo-mechanical activity. Moreover, an attempt to activate this process by heating up to ~313 K resulted in a second transformation manifested by the color change. In order to understand the nature of the observed transformations magnetochemical and variable temperature SC XRD (200-315 K) experiments were conducted.

We performed SC–SC transformation and succeeded in crystal structure determination of [Cu(hfac)<sub>2</sub>L]<sub>2</sub>-I and [Cu(hfac)<sub>2</sub>L]<sub>2</sub>-II. It was found that modifications I and II could reversibly transform one into another upon temperature variation. Temperature increase above ~293 K provokes transition of [Cu(hfac)<sub>2</sub>L]<sub>2</sub>-I into [Cu(hfac)<sub>2</sub>L]<sub>2</sub>-II. We managed to solve structures of the generated new phases inside [Cu(hfac)<sub>2</sub>L]<sub>2</sub>-II too. XRD data proved that the initial molecular dimer [Cu(hfac)<sub>2</sub>L]<sub>2</sub>-II transformed to the polymeric chain compound [Cu(hfac)<sub>2</sub>L]<sub>∞</sub>. This unique phase transition requires severe structural distortions, Cu–N bonds breaking and new Cu–N and Cu–O bonds formation. Furthermore, it was found that after 5 hours of the experiment reflections from [Cu(hfac)<sub>2</sub>L]<sub>∞</sub> started to weaken and reflections of another new phase appeared. We were lucky to solve the structure of this new phase. All the transformations revealed by SC XRD are in agreement with magnetochemical data and presented below.



**Figure 1.** Scheme of the [Cu(hfac)<sub>2</sub>L]<sub>2</sub>-I ↔ [Cu(hfac)<sub>2</sub>L]<sub>2</sub>-II → [Cu(hfac)<sub>2</sub>L]<sub>∞</sub> → [Cu(hfac)<sub>2</sub>L\*]<sub>∞</sub> transformation.

### References

- [1] V. Ovcharenko, E. Bagryanskaya. Breathing Crystals from Copper Nitroxyl Complexes / In: *Spin-Crossover Materials: Properties and Applications*, Ed. M. A. Halcrow, Wiley-VCH, New York, **2013**. 239-280.
- [2] K. Yu. Maryunina, et al. *J. Mater. Chem. C* **2015**, 3, 7788-7791.
- [3] M. V. Fedin, et al. *Coord. Chem. Rev.* **2015**, 289–290, 341–356.
- [4] Golomolzhina I.V. et al. Mendeleev 2021, St. Petersburg, 6-10 September **2021**.

Acknowledgements. This work was supported by the Russian Science Foundation (project No 18–13–00380) and Ministry of Education of the Russian Federation (scholarship of President of the Russian Federation for young scientists and graduate students) (project No SP-5633.2021.5).

# SYNTHESIS OF THE DERIVATIVES OF CLOSO-BORATE ANIONS WITH CROWN-ETHERS

*Levitskaia V. Ya.*<sup>1</sup>, *Novikov S.S.*<sup>1</sup>, *Matveev E. Yu.*<sup>1,2</sup>, *Zhizhin K. Yu.*<sup>1,2</sup>

<sup>1</sup> MIREA – Russian Technological University, Moscow, Russia

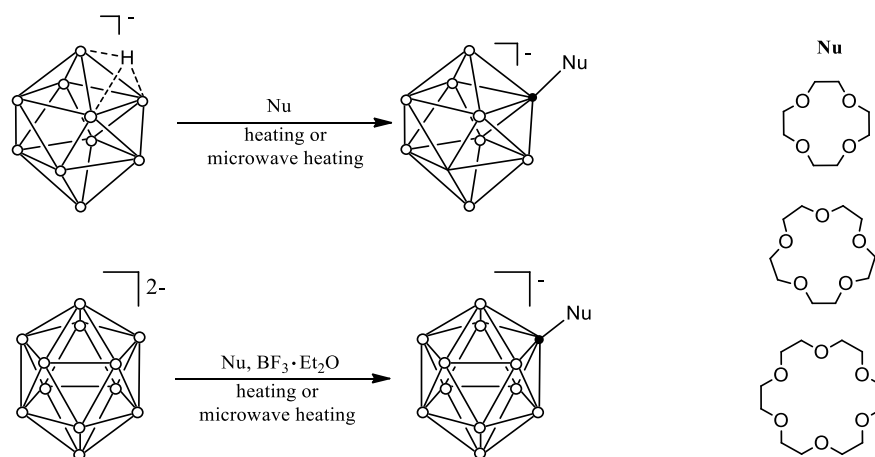
<sup>2</sup> Kurnakov Institute of General and Inorganic Chemistry, Russia

Student

[valeriialy9@gmail.com](mailto:valeriialy9@gmail.com)

Derivatives of the *closo*-borate anions  $[B_{10}H_{10}]^{2-}$  and  $[B_{12}H_{12}]^{2-}$  are currently attracting great attention as compounds that are promising for use in diagnostics and  $^{10}B$  neutron capture therapy of oncological diseases. [1-2]. One of the most interesting classes of such compounds are *closo*-borates with pendant functional groups. Convenient starting substances for their synthesis are derivatives of the anions  $[B_nH_n]^{2-}$  ( $n = 10, 12$ ) with cyclic substituents of the oxonium type [3-4].

In this work, it was shown that the interaction of salts of the anion  $[B_{10}H_{11}]^-$  or  $[B_{12}H_{12}]^{2-}$  (in the presence of  $BF_3 \cdot Et_2O$ ) with various crown ethers (12-crown-4, 15-crown-5, 18-crown-6), monosubstituted derivatives with a substituent in the equatorial position are formed. These reactions take place both with normal heating and with exposure to microwave radiation. The second method is much more preferable, since it allows the target reactions to be carried out in a short time (10-15 minutes) and in high yields (86-92%).



**Figure 1.** Synthesis of the derivatives of  $[B_{10}H_{10}]^{2-}$  и  $[B_{12}H_{12}]^{2-}$  anions with crown-ethers.

The obtained compounds can be used for the synthesis of *closo*-borates with pendant functional groups by opening the cyclic substituent. Varying the introduced crown ether makes it possible to change the length and structure of the resulting spacer chain and, accordingly, the properties of the target boron-containing derivative. The obtained derivatives of *closo*-borate anions can be promising for  $^{10}B$ -NCT of malignant tumors.

## References

- [1] R. F. Barth, MGraca H. Vicente, O. K. Harling, W. S. Kiger, K. J. Riley, P. J. Binns, F. M. Wagner, M. Suzuki, T. Aihara, I. Kato and S. Kawabata, *Radiat. Oncol.*, **2012**, *7*, 146
- [2] R. L. Moss, *Appl. Radiat. Isot.*, **2014**, *88*, 2
- [3] E.Y. Matveev, I.P. Limarev, A.I. Nichugovskii, A.Y. Bykov, K.Y. Zhizhin, N.T. Kuznetsov, **2019**, *Russ. J. Inorg. Chem.*, *64*, 977–983
- [4] A.A. Semioshkin, I.B. Sivaev, V.I. Bregadze, Cyclic oxonium derivatives of polyhedral boron hydrides and their synthetic applications, *Dalt. Trans.*, 2008, **11**, 977–992

*Luchinin N.D.*<sup>1</sup>, *Aksyonov D.A.*<sup>1</sup>, *Morozov A.V.*<sup>1</sup>, *Ryazantsev S.V.*<sup>1,2</sup>  
*Nikitina V.A.*<sup>1</sup>, *Abakumov A.M.*<sup>1</sup>, *Antipov E.V.*<sup>2,1</sup>, *Fedotov S.S.*<sup>1</sup>

<sup>1</sup>Skolkovo Institute of Science and Technology, Moscow, Russia

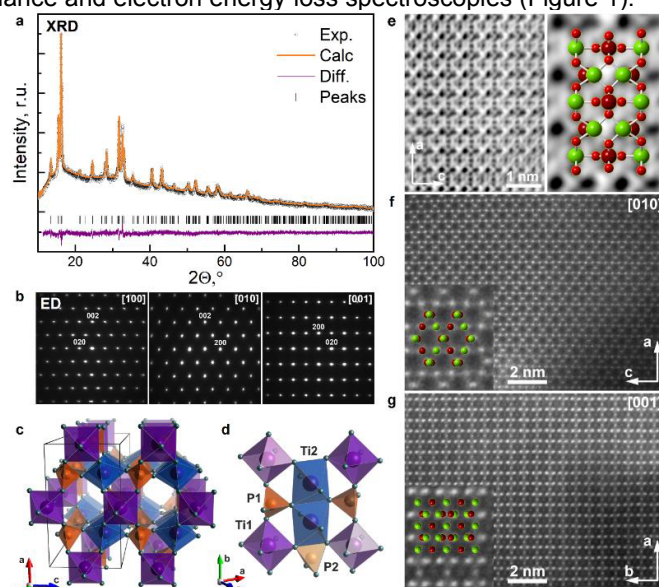
<sup>2</sup>Moscow State University, Moscow, Russia

PhD Student

[Nikita.Luchinin@skoltech.ru](mailto:Nikita.Luchinin@skoltech.ru)

To realize high-power performance, Li-ion batteries require stable, environmentally benign, and economically viable non-carbonaceous anode materials capable to operate at high rates with low strain during charge-discharge. In this work, we report on the synthesis, crystal structure and electrochemical properties of a new titanium-based member of the MPO<sub>4</sub> phosphate series adopting the  $\alpha$ -CrPO<sub>4</sub> structure type<sup>1,2,3</sup>.

$\alpha$ -TiPO<sub>4</sub> has been obtained by a thermal decomposition of a novel hydrothermally prepared fluoride phosphate, NH<sub>4</sub>TiPO<sub>4</sub>F, at 600°C in H<sub>2</sub> atmosphere. The crystal structure of  $\alpha$ -TiPO<sub>4</sub> is Rietveld-refined from powder X-ray diffraction data and verified by electron diffraction and high-resolution scanning transmission electron microscopy, whereas the chemical composition is confirmed by infrared, X-ray energy-dispersive, electron paramagnetic resonance and electron energy loss spectroscopies (Figure 1).



**Figure 1.** a) Rietveld refinement of  $\alpha$ -TiPO<sub>4</sub> b) ED patterns of  $\alpha$ -TiPO<sub>4</sub> along three main zone axes. c)  $\alpha$ -TiPO<sub>4</sub> crystal structure along the [010] axis. d) Enlarged fragment of  $\alpha$ -TiPO<sub>4</sub> crystal structure. e) [010] ABF- and f) HAADF-STEM images as well as g) [001] HAADF-STEM image of  $\alpha$ -TiPO<sub>4</sub>. Enlarged representative fragments are given on the insets with corresponding crystal structure projections (Ti, P and O atoms are designated with dark red, green and light red spheres, respectively).

Carbon-coated  $\alpha$ -TiPO<sub>4</sub>/C demonstrates reversible electrochemical activity ascribed to the Ti<sup>3+</sup>/Ti<sup>2+</sup> redox transition delivering 125 mAh/g specific capacity at C/10 in the 1.0-3.1 V vs. Li<sup>+</sup>/Li potential range with an average potential of ~1.5 V exhibiting good rate capability and stable cycling with volume variation not exceeding 0.5%. Below 0.8 V the material undergoes a conversion reaction further revealing capacitive reversible electrochemical behavior with average specific capacity of 270 mAh/g at 1C in the 0.7-2.9 V vs. Li<sup>+</sup>/Li potential range. This work suggests a new synthesis route to metastable Ti-containing phosphates holding perspective to be used as negative electrode materials for metal-ion batteries.

### References

- [1] Christian Masquelier and Laurence Croguennec, Polyanionic (Phosphates, Silicates, Sulfates) Frameworks as Electrode Materials for Rechargeable Li (or Na) Batteries // *Chem. Rev.*, 2013
- [2] Attfield J.P., Sleight A.W., Cheetham A.K., *Nature*, **1986**, 322, 620–622.
- [3] Fedotov S.S., Samarin A.Sh., Nikitina V.A., Stevenson K.J., Abakumov A.M., Antipov E.V., *ACS Appl. Mater. Interfaces* **2019**, 11, 12431-12440

Acknowledgements. This work was supported by Russian Science Foundation (grant # 17-73-30006).

NOVEL POLYOXOVANADATE-Pt(II) MOLECULAR HYBRIDS:  
NEW MEMBERS OF MOLECULAR JUNCTION FAMILY

*Luginin M.E., Petrovskii S.K.*

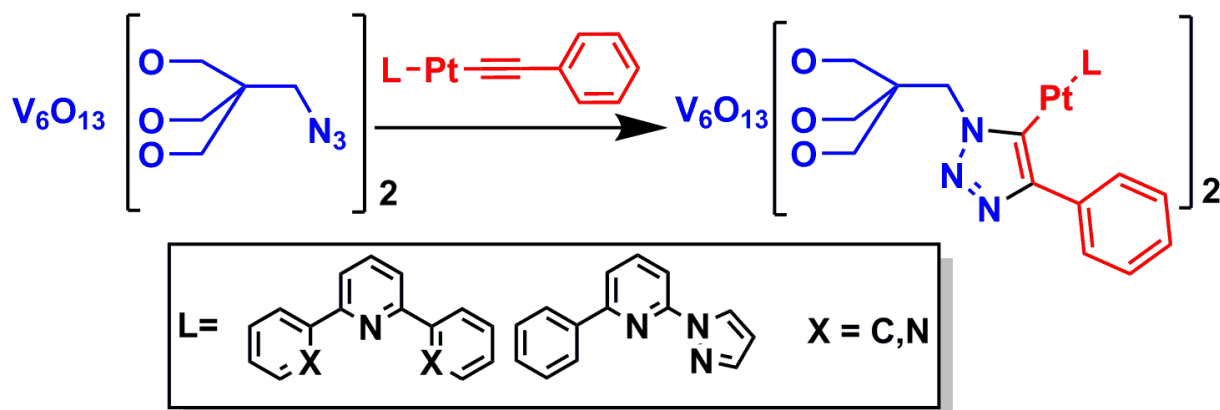
Institute of Chemistry, Saint Petersburg State University, Saint Petersburg, Russia

Student

[maclugin@yandex.ru](mailto:maclugin@yandex.ru)

The rapid development of microelectronics has led to the situation that at the moment attempts to miniaturize CMOS devices are faced with more complex problems. One of the ways to solve these problems is the creation and development of new molecular materials, which should become the basis for a qualitative leap in the miniaturization of logic elements and could lead to the creation of molecular electronics, for example, multiple-state resistive (MRS, memristive) materials. It has been shown that Lindquist polyoxometalate (POM) decorated with organic moieties could be excellent candidates for the creation of materials acting as molecular tunnel junctions. [1]

Lindquist polyoxovanadates  $\{V_6\}$  grafted by tris(alkoxo) ligands provide great possibilities of structural modifications. Recently it has been shown that approach of 'click' chemistry can be efficiently utilized for the synthesis of  $\{V_6\}$ -Organogold hybrid structures, demonstrating very intriguing electronic characteristics in terms of their application as memristive junctions. [2] Current work is aimed at the expanding the range of similar molecular hybrids by including Pt(II) center with coordinated Pincer-type tridentate ligands of different nature (Fig. 1).



**Figure 1.** Synthesis of  $\{V_6\}$ -Pt(II) molecular hybrids

The  $\{V_6\}$ -Pt(II) hybrids obtained could be anticipated of great interest for potential use as molecular junctions. The incorporation of Pt(II) center could provide electronic effects, which is severally tuned by the nature of pincer ligand, while the flat square-planar structure of Pt(II) moiety should lead to the enhanced adsorption on surfaces (Au (111), graphite, etc.) due to non-covalent interactions and efficient electric interaction between them.

#### References

- [1] Linnenberg, O. et al. *J. Am. Chem. Soc.* **2018**, *140*, 16635–16640  
[2] Petrovskii, S. K. et al. *Inorg. Chem.*, **2020**, *59*, 16122–16126

Acknowledgements. This work was supported by the Russian Science Foundation (project 21-13-00052). The studies were performed using the equipment of Centres for Magnetic Resonance, for Chemical Analysis and Materials Research and Center for Thermogravimetric and Calorimetric Research (Research Park of St. Petersburg State University).

# KINETICS STUDY OF SOLVENT AND SOLID-PHASE EXTRACTION OF YTTRIUM FROM PHOSPHORIC ACID SOLUTIONS

*Lukyantseva E.S., Sergeev V.V.*

Saint Petersburg Mining University, Saint Petersburg, Russia

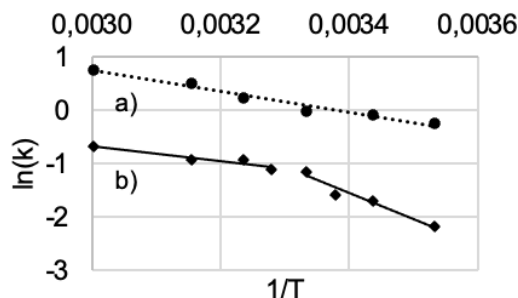
Student

[lukyantseva\\_lena@inbox.ru](mailto:lukyantseva_lena@inbox.ru)

Rare-earth elements (REE) are a pivotal raw material for most knowledge-intensive industries due to their specific magnetic, optical, and electrical properties. In ores containing lanthanides and yttrium, REE are found in low concentrations in the presence of numerous impurity compounds. When processing such ores, complex multi-component solutions with extremely low pH values are formed. Extraction is widely used as the method for obtaining REE from these solutions since it allows their concentration and separation. In Russia that ranks fourth worldwide in terms of rare-earth elements reserves [1], REEs' main source is apatite, which has been systematically introduced in the production of mineral fertilizers.

Solutions of phosphoric acid obtained after the sulfuric acid leaching of apatite contain up to 0.1% REE and were chosen as the object of research. Solvent extraction using di-2-ethylhexylphosphoric acid (D2EHPA) as the extractant was studied as well as solid-phase extraction using Levextrel resin impregnated with D2EHPA. D2EHPA, being a cation-exchange extractant, is able to interact and form organic complexes not only with REE but also with impurity compounds of iron (3+), the content of which in the phosphoric acid solutions is several times higher than the content of REE. Thus, in addition to the kinetic aspects of REE extraction on the example of yttrium, the research considered also the kinetics of iron (3+) extraction.

To identify the limiting stage of the extraction process, the influence of the extraction conditions was studied. Experimental data has shown that during the solvent extraction of yttrium, the stirring rate has a greater effect on the equilibrium ratio than the temperature. Thus, the limited stage is diffusion. At the same time, the limiting stage of the iron (3+) extraction changes with increasing temperature: at a temperature of up to 300 K, the limiting stage is the chemical reaction; at a temperature of 305 K to 333 K, the extraction rate is limited by diffusion (Figure 1). For better separation of yttrium and iron, it is feasible to conduct extraction at a temperature of up to 300 K, when the limiting stages are different. The extraction time should not exceed two minutes since the equilibrium of yttrium extraction is achieved faster than the equilibrium of iron (3+). Such decision makes it possible to increase the separation coefficient for Y/Fe to 23.2.



**Figure 1.** The dependence of  $\ln(k)$  on the reciprocal temperature for a) yttrium, b) iron.

It takes much longer to establish the equilibrium in the case of solid-phase extraction. To reduce the required time from 2 to 1 hour, it is necessary to increase the temperature to 330 K. The extraction rate is not significantly affected by the temperature and intensity of stirring. The experiment was carried out at the ratio of the sorbent mass and the volume of the solution of 1:10 to ensure the extraction degree of yttrium of at least 80%.

In contrast to solvent, during solid-phase extraction, it is impossible to create non-equilibrium conditions for reducing the degree of iron (3+) extraction into the sorbent. Nevertheless, it is significantly lower and does not exceed 9%, while in solvent extraction it is up to 20%, which is explained by the different configurations of the extractant in the matrix. The calculated activation energy of solid-phase extraction is distinctive for gel kinetics. In other words, the process is limited by diffusion in the grain. By and large, solid extractant has an undoubted technological advantage since it reduces the dependence of the extraction degree on both temperature factor and the stirring ratio.

## References

[1] United States Geological Survey **2021**, Mineral commodity summaries 2021: U.S. Geological Survey, 200 p.

Acknowledgements. This work was supported by the Russian Science Foundation (project No 19 19 00377).

# PHOSPHORESCENT N<sup>^</sup>C<sup>^</sup>N-CYCLOMETALATED PLATINUM(II) COMPLEXES AND THEIR PHOTOPHYSICAL PROPERTIES

Luneva E.E.<sup>1</sup>, Solomatina A.I.<sup>1</sup>, Kozina D.O.<sup>1</sup>

<sup>1</sup>Saint Petersburg State University, Saint Petersburg, Russia  
[yevegeniyalunyova@gmail.com](mailto:yevegeniyalunyova@gmail.com)

The application of luminescence is widespread. It's used in electronics (for example, OLEDs), biology, optics, and medicine. Among the variety of luminescent compounds, phosphorescent transition metal complexes attract exceptional interest, due to its longer lifetimes and larger Stokes shifts.

Herein we demonstrate synthesis of new pincer N<sup>^</sup>C<sup>^</sup>N-ligand and its platinum(II) complexes. The ligand 1,3-bis(1-phenyl-1*H*-phenanthro[9,10-*d*]imidazol-2-yl) benzene was obtained by heating of phenanthrene-9,10-dione, aniline, and isophthalaldehyde at 70 °C (figure 1). The reaction yield was slightly over 42%.

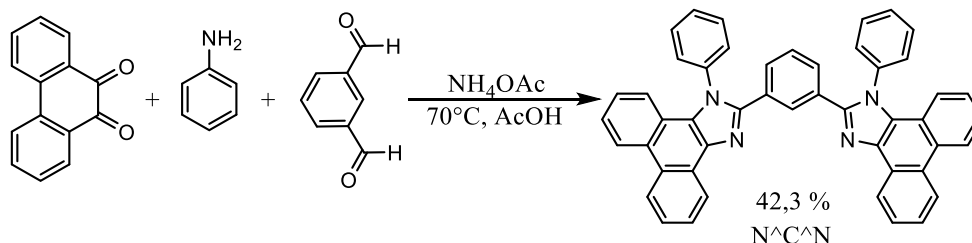


Figure 1. Synthesis of N<sup>^</sup>C<sup>^</sup>N ligand.

Based on this ligand, a series of platinum(II) complexes were obtained. The complex [Pt((1,3-bis(1-phenyl-1*H*-phenanthro[9,10-*d*]imidazol-2-yl)benzene)Cl)] was synthesized from K<sub>2</sub>[PtCl<sub>4</sub>] in an acetic acid solution under reflux. The following functionalization of the complex was carried out with the replacement of the chlorine atom by acetonitrile and pyridine with Ag[PF<sub>6</sub>] without access to light at RT (figure 2a). The obtained complexes were characterized by using NMR-spectroscopy, mass-spectrometry, and XRD analysis. The luminescence properties of all compounds were studied. In dichloromethane solution, the complexes luminesce in the blue-green region of the visible spectrum (figure 2b). The nature of excited state was also studied by means of DFT method.

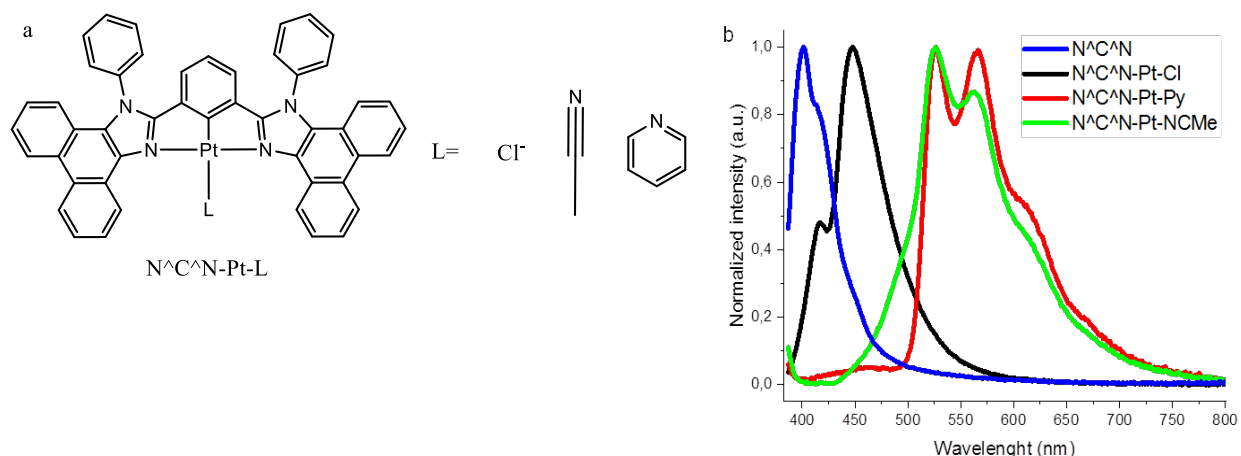


Figure 2. a – Structures of the obtained complexes; b – luminescence spectrum in DCM.

## References

[1] A. I. Solomatina, K. M. Kuznetsov, V. V. Gurzhiy, V. V. Pavlovskiy, V. V. Porsev, R. A. Evarestov, S. P. Tunik, *Dalton Trans.*, **2020**, 49, 6751-6763.

Acknowledgements. This work was supported by the grant of the President of the Russian Federation (MK-1953.2021.1.3) using equipment of SPbU Research Park: Chemical Analysis and Materials Research Centre, Centre for X-ray Diffraction Studies and Magnetic Resonance Research Centre.

*Lyakaev D.V., Markin A.V., Smirnova N.N.*

Lobachevsky State University of Nizhni Novgorod, Nizhni Novgorod, Russia  
PhD student  
[lyakaev94@mail.ru](mailto:lyakaev94@mail.ru)

Nowadays organoelement compounds are widely studied because of their potential application in various fields of science, technology and biomedicine. Organometallic compounds have advantages over purely organic compounds in application as catalyzers and reagents in organic synthesis, as photo-catalyzer in the degradation of polymeric materials as carbon dioxide absorbers and as solar cells elements. The organoelement compounds exhibit antioxidant, antitumor, antimalarial, and antibacterial activities and find out an application against leishmaniasis and hepatitis C. Also antimony derivatives are widely used for the synthesis of metal-containing macromolecular compounds that have fungicidal and biocidal property, heat resistance and radioresistance

The present research reports complex research of the heat capacity organic derivatives of pentavalent antimony  $\text{Ph}_3\text{SbX}_2$ , where X are organic ligands  $-\text{OC}(\text{O})\text{Ph}$ ,  $-\text{OC}(\text{O})\text{C}_2\text{H}_5$ ,  $-\text{OC}(\text{O})\text{C}\equiv\text{CPh}$   $-\text{OC}(\text{O})\text{C}_{10}\text{H}_{15}$ , and  $-\text{Ph}$ . By methods adiabatic vacuum calorimetry (AVC) and differential scanning calorimetry (DSC) the temperature dependence of the heat capacity understudy compounds were determined in the wide temperature range.

Heat capacity of samples was measured over the range 6–300 K in a BKT-3.0 fully automatic adiabatic vacuum calorimeter with liquid helium and nitrogen used as cooling agents. The measurements were carry out with an error not exceeding  $\pm 2\%$  at  $T = (5 \text{ to } 15) \text{ K}$ ,  $\pm 0.5\%$  between 15 and 40 K and  $\pm 0.2\%$  in the range from 40 to 300 K. The phase transition temperatures are measured within about  $\pm 0.01 \text{ K}$  and the enthalpies of transformations with the error of  $\pm 0.2\%$ .

Thermal behavior of samples in the range from 300 K to decomposition temperatures was investigated with the differential scanning calorimeter DSC204F1 Germany, Netzsch Gerätebau. The determined values correspond to an error of  $\pm 0.5 \text{ K}$  in temperature and  $\pm 1\%$  in the enthalpy of transition.

The phase transitions were identified, and their thermodynamic characteristics were defined and analyzed with according to composition and structure. As a result, the interpretation of influence of ligands was made. For some compounds from investigative rank transition from glassy to over-cooled state was revealed.

The thermal stability of the compounds under study was determined by the method of thermogravimetric analysis. It was done using thermal microbalance TG209F1, Germany, Netzsch Gerätebau.

The complex of standard thermodynamic functions (heat capacity  $C_p^0$ , enthalpy  $H^0(T) - H^0(0)$ , entropy  $S^0(T)$ , and Gibbs energy  $G^0(T) - H^0(0)$ ) was calculated over the range from  $T \rightarrow 0$  to the onset decomposition temperatures for the compounds. The energy of combustion, standard enthalpy of combustion, formation enthalpy, formation entropy, Gibbs energy of formation of substances in the crystalline state at  $T = 298.15 \text{ K}$  were calculated.

Multifractal treatment of low-temperature heat capacity was made as a result topological structure of the compound was established and the chain-layered structure topology of the compounds under study was defined. Debye characteristic temperatures were calculated and structure hardness of samples was evaluated.

As results practically dependences type as thermodynamic properties vs composition were established. They allow to predict the thermophysical properties for compounds of its class.

Acknowledgements. This work was supported by the Russian Foundation for Basic Research, project no. 18-03-01090 A.



EXCITATION-WAVELENGTH-DEPENDENT EMISSION OF ZINC(II) HALIDE COMPLEXES WITH 2-[6-(1H-PYRAZOL-1-YL)PYRIMIDIN-4-YL]PHENOL

*Malakhova Yu. A.*<sup>1,2</sup>, *Berezin A. S.*<sup>1,2</sup>, *Krivopalov V. P.*<sup>3</sup>, *Nikolaenkova E. B.*<sup>3</sup>, *Naumov D. Yu.*,  
*Bushuev M. B.*<sup>1,2</sup>, *Vinogradova K. A.*<sup>1,2</sup>

<sup>1</sup>Novosibirsk State University, Novosibirsk, Russia

<sup>2</sup>Novosibirsk Institute of Inorganic Chemistry, Novosibirsk, Russia

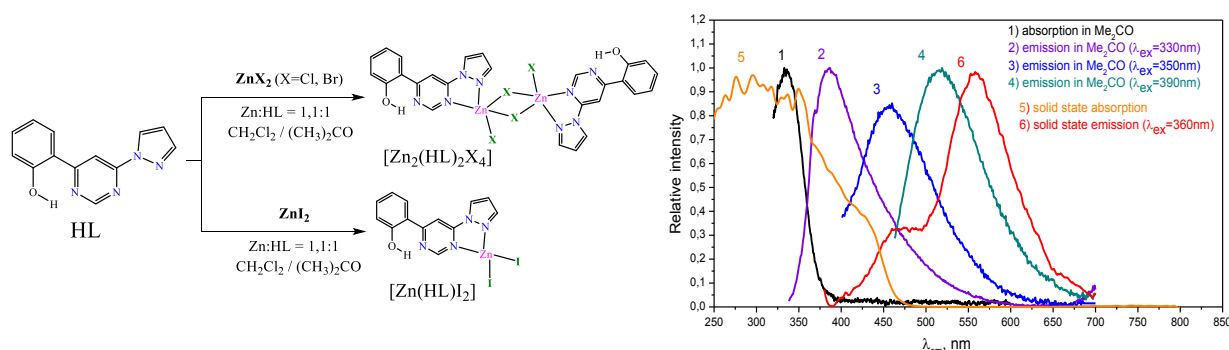
<sup>3</sup>*N. N. Vorozhtsov Novosibirsk Institute of Organic Chemistry, Novosibirsk, Russia*

Student

[y.malakhova@g.nsu.ru](mailto:y.malakhova@g.nsu.ru)

Recently, a zinc(II) complex with a 4-(2-hydroxyphenyl)pyrimidine derivative containing a short intramolecular OH...N hydrogen bond was published, it exhibit excitation-wavelength depending emission in the solid state [1]. This unique effect is a result of a number of processes caused by photoexcitation: intramolecular proton transfer, thermally activated delayed fluorescence and emission with violation of Kasha's rule.

The purpose of the work is to synthesize and study the photoluminescent properties of zinc(II) complexes with a new 4-(2-hydroxyphenyl)pyrimidine derivative. Zinc(II) halide complexes with 2-[6-(1H-pyrazol-1-yl)pyrimidin-4-yl]phenol (HL) were synthesized by a reaction of ZnX<sub>2</sub> with HL in 1:1:1 molar ratio (Fig. 1, left). According to the X-ray single crystal analysis the zinc(II) chloride and bromide complexes have binuclear structure [Zn<sub>2</sub>(HL)<sub>2</sub>X<sub>4</sub>], the iodide complex has mononuclear structure [ZnHLI<sub>2</sub>]. In [Zn<sub>2</sub>(HL)<sub>2</sub>X<sub>4</sub>] complexes coordination core of zinc atom is a distorted square pyramid (ZnN<sub>2</sub>Cl<sub>3</sub>). The coordination core in the iodide zinc(II) complex is more typical for zinc(II) complexes, it is distorted tetrahedron. The compound HL and the discussed complexes contain a short intramolecular OH...N hydrogen bond, the distance O...N is about 2.6 Å.



**Figure 1.** Synthesis of zinc(II) halide complexes (left). Photophysics properties of [ZnHLI<sub>2</sub>] (right).

Photoluminescent properties of obtained complexes and the compound HL were investigated in the solid state and in solutions (Fig. 1, right). The solid-state emission of [Zn<sub>2</sub>(HL)<sub>2</sub>X<sub>4</sub>] (X = Cl, Br) complexes depends on excitation energy. When excited by 240–360 nm “red” emission is observed (for [Zn<sub>2</sub>(HL)<sub>2</sub>Cl<sub>4</sub>] λ<sub>em</sub> = 640 nm, for [Zn<sub>2</sub>(HL)<sub>2</sub>Br<sub>4</sub>] λ<sub>em</sub> = 660 nm), meanwhile lower energy excitation (460–480 nm) leads to «yellow» emission which has maxima at 585 and 600 nm, correspondingly. This tendency is not so pronounced for the iodide zinc(II) complex, at various excitation wavelengths in the luminescence spectra of this complex there is only one broad emission band at 570–580 nm.

The emission of HL in solutions depends on polarity of a solvent. In DMSO solution there are two emission bands with maxima at 410 and 530 nm, in acetone solution there is emission band with a maximum at 400 nm. The emission of the synthesized iodide zinc(II) complex is observed only in acetone. Depending on the excitation, in the emission spectrum of the complex three bands can be observed at 390, 460 and 520 nm. It is assumed that the band at 390 appears due to partial dissociation of the complex and belongs to the ligand spectrum. Two other bands belong to the zinc(II) iodide complex itself.

## References

[1] A.S. Berezin, K. A. Vinogradova, V. P. Krivopalov, E. B. Nikolaenkova, V. F. Plyusnin, A. S. Kupryakov, N. V. Pervukhina, D. Y. Naumov, M. B. Bushuev. *Chem. Eur. J.* **2018**, *24*, 12790.

Acknowledgements. The research was supported by the President of the Russian Federation Grant for Young Scientists (project № MK-1219.2020.3.).

# EFFECT OF OXYGEN ON THE PROCESS OF DECOMPOSITION OF THE DINITROSYL IRON COMPLEX WITH N-ETHYLTHIOUREA LIGANDS

Marina A.V.<sup>1,2</sup>, Pokidova O.V.<sup>2</sup>, Emel'yanova N.S.<sup>1,2</sup>, Sanina N.A.<sup>1,2,3</sup>

<sup>1</sup>Moscow State University, Moscow, Russia

<sup>2</sup>Institute of Problems of Chemical Physics of the Russian Academy of Sciences, Chernogolovka, Russia

<sup>3</sup>Medicinal Chemistry Research and Education Center, Moscow Region State University, Mytishchy, Russia

Student

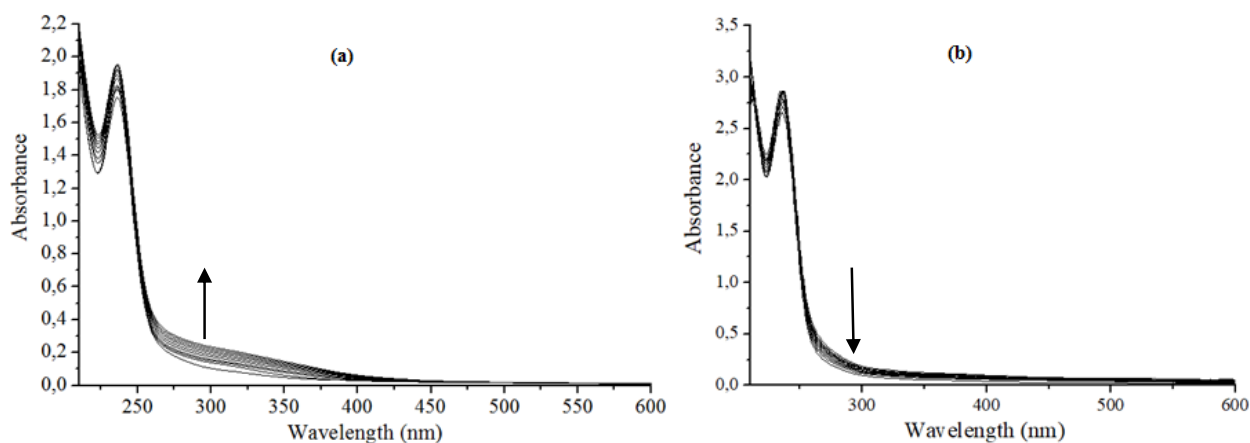
[shuremana@yandex.ru](mailto:shuremana@yandex.ru)

Nitrogen monoxide (NO) is one of the most important molecules that affect various biochemical and physiological processes *in vivo*. In medicine, medications based on exogenous NO donors are widely used. Their action is aimed at the release of molecule nitric oxide in a free form. However, there are disadvantages of these drugs as additional activation, the development of effect of the tolerance. Therefore, an important direction in medical and biochemical fields is the synthesis and study compounds that can efficiently deliver NO and have minimum disadvantages.

Dinitrosyl iron complexes (DNICs) with functional sulfur-containing ligands are perspective compounds for using them as exogenous NO donors. DNICs generate NO spontaneously during hydrolysis. It is known that in aerobic solutions oxygen is incorporated into various bonds in the structure of the complex. Based on this fact, there are various reaction paths which will lead to the formation of the number of products [1].

In this work we studied mononuclear cationic complex with N-ethylthiourea ligands (ETM)  $[\text{Fe}(\text{SC}(\text{NH}_2)(\text{NHC}_2\text{H}_5))_2(\text{NO})_2]^+\text{Cl}^-$   $[\text{Fe}(\text{SC}(\text{NH}_2)(\text{NHC}_2\text{H}_5))\text{Cl}(\text{NO})_2]^0$  synthesized in Laboratory of Structural Chemistry in IPCP RAS [2]. This complex has a high selective toxicity towards A-172 glioblastoma cells [3].

The present work was aimed at the studying the effect of oxygen on transformation process of ETM. Studies were carried out under anaerobic and aerobic conditions. It was shown (Fig.1a) that in the spectra under aerobic conditions in the region of 280-370 nm, the formation of a wide shoulder is observed, whereas it is absent under anaerobic conditions (Fig.1b). These results indicate the formation of products of the interaction of the complex with oxygen.



**Figure 1.** The change in the absorption spectra of ETM with time under aerobic (a) and anaerobic (b) conditions.

Also, the NO-donor activity of the complex was compared under anaerobic and aerobic conditions using a selective sensor electrode and the Griess reaction (according to the kinetics of accumulation of nitrite ions). It was found that the complex releases NO-groups faster and more efficiently in the air. To assess the effect of oxygen, we used the quantum-chemical method in order to model the interaction of the complex with oxygen and to calculate possible reaction products.

## References

- [1] Emel'yanova N.S., Pokidova O.V. *Inorg. Chimica Acta* **2021**, 522, 120361
- [2] Sanina N.A., Shmatko N.Y. *J. of Coord. Chem.* **2016**, 69(5), 812–825
- [3] Sanina N.A., Shmatko N.Y. *Molecules* **2017**, 22(9), 1426

Acknowledgements. This work was supported by a grant from the Russian Science Foundation (project No. 20-73-00316)

# INVESTIGATION OF Cr<sub>2</sub>O<sub>3</sub>/SiO<sub>2</sub> CATALYSTS BEHAVIOR IN THE REACTION OF OXYDATIVE DEHYDROGENATION OF PROPANE IN PRESENCE OF CO<sub>2</sub>

*Mashkin M.Y., Tedeeva M.A., Fedorova A.A., Kustov A.L.*

Moscow State University, Moscow, Russia

Student

[mashkin5482@mail.ru](mailto:mashkin5482@mail.ru)

Propylene is industrially important raw material which is used in the synthesis of cumene, acrylonitrile, acrylic acid, propylene oxide, isopropyl alcohol, polypropylene [1]. Chromium (III) oxide is one of the most promising material in the studies in catalysis devoting to production of propylene. The catalytic behavior of the material is strongly affected by chromia particles. In order to obtain small-size chromium (III) oxide particles it is possible to use the carriers with developed pore structure. The convenient synthesis of silicas with the developed surface area includes the using of template, for example, beta-cyclodextrin. This compound is a cyclic oligosaccharide comprising six D-glucopyranoside units, linked by 1,4-glycosidic bonds. The molecules of beta-cyclodextrin have a truncated cone shape [2], and they are able to form the stem-like assemblies and possibly to create pores with 'worm-like' shape [3].

The first stage of synthesis was the pre-hydrolysis of tetraethyl orthosilicate with 0.1M HNO<sub>3</sub> water solution. Further we added the template solution (beta-cyclodextrin and urea) in amounts of 60% according the following formula:  $m_{\text{template}} = [m_{\text{Cyclodextrin}} + m_{\text{Urea}}] / [m_{\text{Cyclodextrin}} + m_{\text{Urea}} + m_{\text{SiO}_2}] * 100\%$ . Amounts of water were following:  $m_{\text{H}_2\text{O}} = 1.5 * m_{\text{SiO}_2}$  (series SiO<sub>2</sub>-1.5),  $5 * m_{\text{SiO}_2}$  (series SiO<sub>2</sub>-5),  $20 * m_{\text{SiO}_2}$  (series SiO<sub>2</sub>-20). The samples were left for 2 weeks to gel and to age. The chromium (III) oxide was introduced by wetness impregnation with chromium (III) nitrate, then the samples were dried and annealed. We prepared the samples with 3, 5 and 7 wt.% Cr on each silica.

Obtained samples of silicas were investigated via BJH and BET techniques to reveal the pore structure. Table 1 shows that silicas have narrow pore size distribution and the more water amount was added – the larger pore diameter was formed. All samples have large surface areas and all pores are mesopores. There are no micropores in the examined samples.

**Table 1.** The pore structure obtained via BET and BJH methods.

Sample	S <sub>BET</sub> , m <sup>2</sup> /g	V <sub>total</sub> , cm <sup>3</sup> /g	V <sub>meso</sub> , cm <sup>3</sup> /g	D <sub>max/range</sub> , nm
SiO <sub>2</sub> -1.5	682	1.152	1.152	7 / 3-10
SiO <sub>2</sub> -5	463	1.020	1.020	9 / 4-11
SiO <sub>2</sub> -20	409	0.997	0.997	10 / 4-13

The obtained samples of catalysts Cr<sub>2</sub>O<sub>3</sub>/SiO<sub>2</sub> were investigated with X-ray before and after catalytic tests. It is revealed that there are no meaning changing in crystalline structure during catalytic experiments. All peaks after catalysis have the same width as they had before catalysis.

All prepared samples were examined with UV-Vis spectroscopy. All samples' curves have four peaks referring to chromium (VI) and chromium (III).

The catalytic tests show that the samples prepared from SiO<sub>2</sub>-5 and SiO<sub>2</sub>-20 exhibit greater performance, that the samples on the carrier SiO<sub>2</sub>-1.5. The samples on SiO<sub>2</sub>-5 have selectivity on propylene up to 80% while conversion is 20% (at 650 °C). If we compare the samples within the series on the carrier SiO<sub>2</sub>-5 it is noticeable that the catalysts with 3 and 7 wt. % of chromium have more attractive behavior than the sample with 5% of Cr. The samples prepared from SiO<sub>2</sub>-5 demonstrate catalytic activity already at 650 °C while the samples from silicas SiO<sub>2</sub>-1.5 and SiO<sub>2</sub>-20 start exhibiting activity only at 700 °C. So, the best catalysts within the investigated series were the catalysts on the carrier SiO<sub>2</sub>-5 with 3 and 7 wt. % of chromium.

## References

- [1] Michorczyk P., Ogonowski J., Zenczak K. *Journal of Molecular Catalysis A* **2011**, 349, 1–12
- [2] Steed J.W., Atwood J.L. *Supramolecular Chemistry*, **2009**, 2<sup>nd</sup> edition, Wiley, 1002
- [3] Polarz S., Smarsly B., Bronstein L., Antonietti M. *Angewandte Chemie Int. Ed.* **2001**, 40, 4417–4421

Acknowledgements. This work was supported by the Russian Science Foundation (grant No 20-73-10106).

# THERMODYNAMIC MODEL FOR THE DESCRIPTION OF THE SORPTION OF EDTACERRATE IONS ON THE CYBBER EV009 ANIONITE

*Mashukova Y.A.<sup>1</sup>, Cheremisina O.V.<sup>1</sup>, Ponomareva M.A.<sup>1</sup>, Sitko A.V.<sup>1</sup>*

<sup>1</sup>Saint Petersburg Mining University

Student

[mya55@mail.ru](mailto:mya55@mail.ru)

Thermodynamic models currently used for sorption equilibria description, have limitations and assumptions associated with a certain process mechanism which leads to the possibility of their application exclusively in a certain concentration range [1]. Therefore, the development of a universal model for describing ion-exchange equilibria with sufficient accuracy for any concentration range is a crucial task. In the course of this work a comparative study of several widely used thermodynamic models was carried out and the use of the linearized mass action law for the mathematical description of sorption processes was proposed.

The experiment was carried out under static conditions using the macroporous weakly basic anionite Cybber EV009 in the nitrate form. The sorption process was studied for EDTAcerrate ions by the method of variable concentrations with continuous stirring for 6 hours in a thermostatically controlled cabinet under following conditions: temperature of 298 K, a solution and sorbent volume ratio of 5:1. The ionic strength was kept constant at 1 mol/kg (NaNO<sub>3</sub>).

Using mathematical transformations, the mass action law was reduced to a linear form:

$$\frac{1}{\Gamma_{\text{EDTA}^-}} = \frac{1}{\Gamma_{\infty}} + \frac{[\text{NO}_3^-] \gamma_{\text{NaNO}_3}^2}{K * \Gamma_{\infty} * [\text{EDTA}^-] * \gamma_{\text{NaEDTA}^-}^2}$$

Linear forms of EDTAcerrate ion sorption isotherms for the anionite Cybber EV009 were constructed using the models of Temkin, Dubinin-Radushkevich, Langmuir, Freundlich, and Flory-Huggins.

The Langmuir and Flory-Huggins models demonstrated a low correlation coefficient with the experimental data, which makes it impossible to use them to describe this ion-exchange equilibrium. According to the Gibbs energy of EDTAcerrate ions sorption of 9.95±0.49 kJ/mol, calculated according to the Dubinin-Radushkevich model, spontaneous flow of the process is impossible. The value of the ion exchange equilibrium constant (K=36434±1821) obtained using the Temkin model is uncharacteristic for sorption processes. The thermodynamic models of Flory-Huggins and Freundlich also cannot be used to describe the equilibrium in the considered system, since the values of the total anionite capacity calculated by these models (1.12±0.06 mol / kg and 1.03±0.05 mol/kg, respectively) do not agree with the data specified in the sorbent certificate (2 mol/kg).

According to the developed model of the linearized mass action law, the ion exchange equilibrium constant (9.00±0.05 mol/kg) was calculated, which was used to calculate the Gibbs energy of EDTAcerrate ions sorption on the Cybber EV009 anionite (-5.54±0.27 kJ/mol), as well as the value of the sorbent total capacity (2.00±0.10 mol/kg). Thus, based on the obtained thermodynamic parameters of sorption, it can be concluded that it is advisable to use linearized mass action law to describe the ion exchange equilibrium of the studied process.

## References

[1] A.O.Dada, A.P. Olalekan, A.M. Olatunya, O. Dada. *J. Appl. Chem.*, **2012**, 3, 38-45

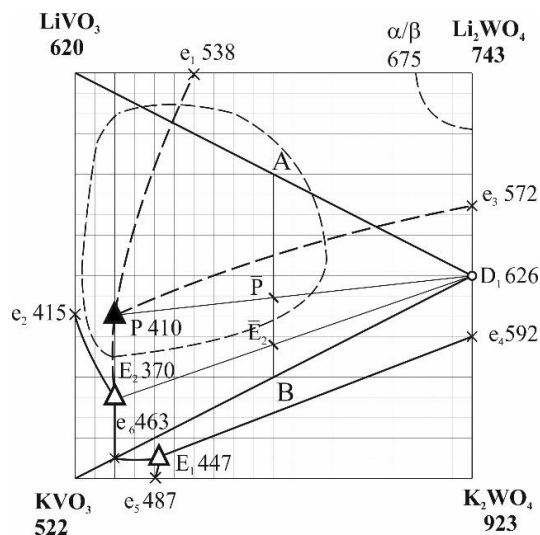
Acknowledgements. This work was supported by project No. 19-19-00377 "Technological basis for the extraction and selection of strategically important rare earth elements from apatite products" dated 22 April, 2019, supported by the Russian Science Foundation in the 2019 competition "Conducting basic scientific research and exploratory research by individual scientific groups".

A partition into simplexes of a three-component reciprocal system Li,K||VO<sub>3</sub>,WO<sub>4</sub> is given in the work [1]. The congruent melting compound LiKWO<sub>4</sub> (D) participates in the splitting. The phase tree consists of three stable triangles – LiVO<sub>3</sub>-Li<sub>2</sub>WO<sub>4</sub>-LiKWO<sub>4</sub>, LiVO<sub>3</sub>-KVO<sub>3</sub>-LiKWO<sub>4</sub>, KVO<sub>3</sub>-K<sub>2</sub>WO<sub>4</sub>-LiKWO<sub>4</sub> separated by two stable secants - LiVO<sub>3</sub>-LiKWO<sub>4</sub>, KVO<sub>3</sub>-LiKWO<sub>4</sub>. An experimental study of a stable triangle LiVO<sub>3</sub>-KVO<sub>3</sub>-LiKWO<sub>4</sub> is presented in [1].

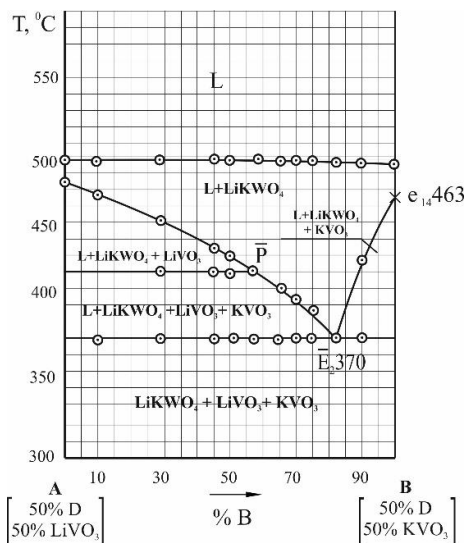
The experimental study of a stable triangle LiVO<sub>3</sub>-KVO<sub>3</sub>-LiKWO<sub>4</sub> was carried out by the method of differential thermal analysis (DTA) [2,3]. The projection of the phase complex of the three-component reciprocal system Li,K||VO<sub>3</sub>,WO<sub>4</sub> onto the composition square is shown in Figure 1. The polythermal section AB [A (50%LiKWO<sub>4</sub>, 50% LiVO<sub>3</sub>); B (50%LiKWO<sub>4</sub>, 50% KVO<sub>3</sub>)] (figure 2) was chosen in the field of crystallization of the compound LiKWO<sub>4</sub>. The direction to the ternary eutectic and its melting point is established - 370°C. The direction to the triple peritectic was also established.

The composition of the ternary eutectic was established by investigation of the polythermal section drawn from the top LiKWO<sub>4</sub> through the direction to the eutectic LiKWO<sub>4</sub>→E<sub>9</sub>→E<sub>9</sub>: 16% (LiVO<sub>3</sub>)<sub>2</sub> + 74% (KVO<sub>3</sub>)<sub>2</sub> + 10% LiKWO<sub>4</sub>. Eutectic composition corresponds to the phase equilibrium: L ⇌ KVO<sub>3</sub> + LiKWO<sub>4</sub> + LiVO<sub>3</sub>.

The study of the system is complicated by the presence of a glass transition region inside the composition triangle. Due to the presence of this area, the position of the triple peritectic was not fixed.



**Figure 1.** Projection of the phase complex of a three-component reciprocal system Li, K || VO<sub>3</sub>, WO<sub>4</sub> per squared compositions



**Figure 2.** T-x-diagram of a polythermal cut AB

### References

- [1] I. K. Garkushin, T. V. Gubanov, A. S. Petrov, B. V. Anipchenko. Phase equilibria in systems with the participation of metavanadates of some alkali metals. M., "Mechanical Engineering-1", 2005. 118 p.
- [2] Verdiev N.N., Verdieva Z.N., Alkhasov A.B. et al. Inorg. Mater., **2020**, 56 (11), 1179-1187.
- [3] Garkushin I.K., Ragrina M.S., Sukharenko M.A. Russ. J. Inorg. Chem. **2018**, 63 (1), 98-103.

*Medyankina I.S.<sup>1</sup>, Pasechnik L.A.<sup>1</sup>*

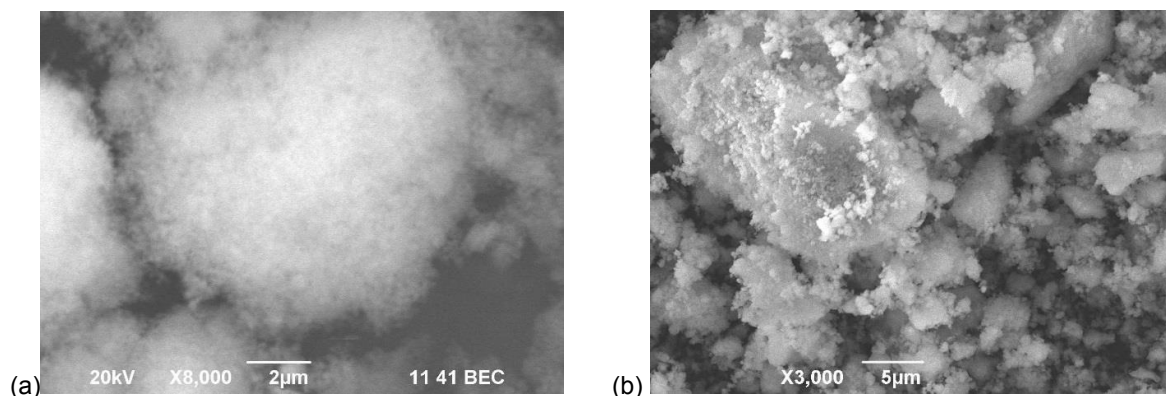
<sup>1</sup> ISSC UB RAS, Ekaterinburg, Russia

PhD student

[lysira90@mail.ru](mailto:lysira90@mail.ru)

Calcium silicates based on amorphous silica (SiO<sub>2</sub>) can be widely used in the production of chromatographic and filter materials, ceramics, adsorbents, as well as composite heat and electrical insulating materials, rubber and plastic fillers, components of paints and pigments, cements and plaster mixtures, heat- and fire-resistant rubber, catalysts [1,2]. At present, silicon-containing waste such as wet magnetic separation tailings of titanium magnetite ore beneficiation and red mud (RM) from the Bayer processing of bauxite into alumina, with silicon content of 10 to 50% are directed to mud storage area. In this light, the present work is related to the obtaining SiO<sub>2</sub> from the fluoride solutions after hydrochemical processing of industrial waste and the synthesis of calcium silicate (wollastonite) based on it. One of the problems is to obtain data on the phase composition of the starting materials and justification for the possibility of creation products.

The solution of ammonium fluorosilicate was obtained from the titanium magnetite tailings which were treated a 5-30% solution of ammonium hydrofluoride for 3-6 h. at a temperature of up to 90°C. The SiO<sub>2</sub> with 90-95% moisture content was obtained from this solution by NH<sub>3</sub>-H<sub>2</sub>O hydrolytically precipitated. A lime CaO component of the composition was obtained by calcination of hydrated or carbonates lime. The CaO together with a SiO<sub>2</sub>-gel was used as a starting material with a molar ratio of CaO:SiO<sub>2</sub> as (1.1-1.2). The prepared mixtures were pressed into stepwise annealed at temperatures of 300, 600 and 850°C for 4 hours at each temperature. The phase compositions of the samples, as well as the microstructures, were analysed by using SEM and X-ray diffraction. SEM of the initial SiO<sub>2</sub> and sintered samples CaCO<sub>3</sub>-SiO<sub>2</sub> are presented in Fig.1. The specific surface area SiO<sub>2</sub> (a) is 360 m<sup>2</sup>/g, the particle size is 1-100nm spherical elongated shape. The resulting wollastonite also has a developed specific surface area, which make possible to use it as an adsorbent.



**Figure 1.** SEM micrographs of (a) initial SiO<sub>2</sub> and sintered sample (b) CaCO<sub>3</sub>-SiO<sub>2</sub>

The XRD patterns of the sintered samples show the presence of a mixture that contained 85% CaSiO<sub>3</sub> and SiO<sub>2</sub> which has not fully reacted. It may be necessary to increase the annealing time at the selected temperatures. With a decrease in the moisture content of the SiO<sub>2</sub>-gel to less than 80%, the reaction of calcium silicate synthesis will be displaced towards the solid-phase process. Thus, for the formation of the wollastonite structure, an increase in the temperature of the charge calcination above 1000 °C

#### References

- [1] Obradovića N, Filipović S. *Ceram. Intern.* **2017**, 43, 7461–7468  
 [2] L. Sun, K. Gong. *Ind. Eng. Chem. Res.* **2001**, 40, 5861–5877

# SYNTHESIS, STRUCTURE, OPTICAL AND ELECTROCHEMICAL PROPERTIES OF CYCLOMETALLATED IRIIDIUM (III) COMPLEXES WITH BENZIMIDAZOLES AND AROMATIC $\beta$ -DIKETONES

Mescheriakova E.A.<sup>1,2</sup>, Tatarin S.V.<sup>1,2</sup>, Bezzubov S.I.<sup>1</sup>

<sup>1</sup>Kurnakov Institute of General and Inorganic Chemistry RAS, Moscow, Russia

<sup>2</sup>Moscow State University, Moscow, Russia

Student

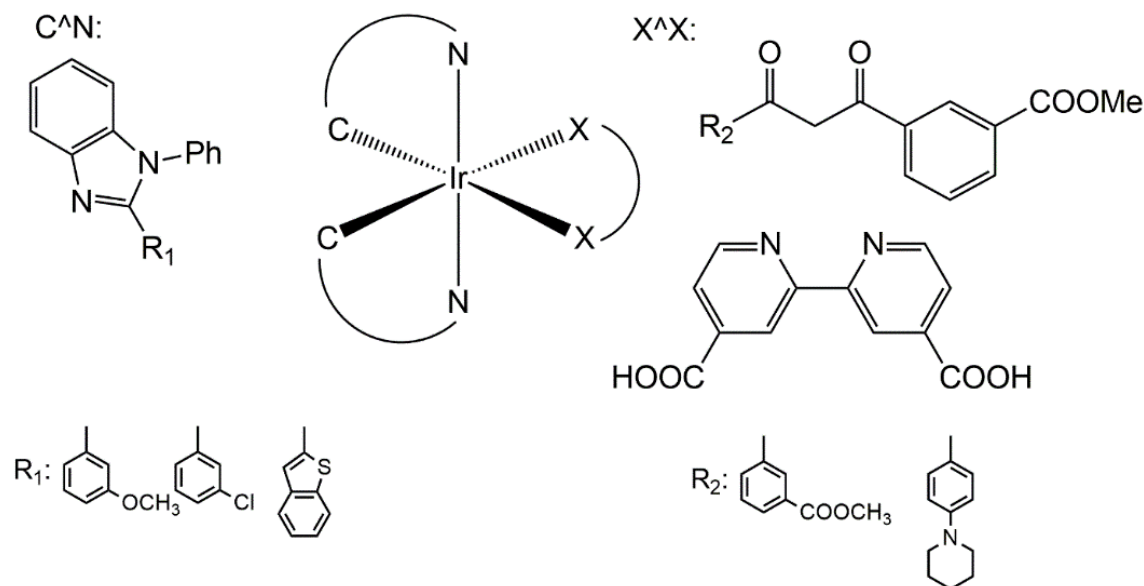
[elizaveta.meshcheriakova@chemistry.msu.ru](mailto:elizaveta.meshcheriakova@chemistry.msu.ru)

Cyclometalated iridium (III) complexes seem to be a more stable alternative to ruthenium (II) photosensitizers in dye-sensitized solar cells (DSSC). Still, poor light absorption in the visible region is the main fundamental drawback of these compounds which prevents their application in solar panels.

Recently it was found that the replacement of traditional 4,4'-dicarboxy-2,2'-bipyridine by asymmetrical aromatic  $\beta$ -diketone bearing a thiophene moiety results in excellent tuning of the redox potentials of the complexes increasing the efficiency of photoanodes twicely [1]. Based on this study, we have assumed that incorporating some functional groups in the "anchoring" ligand of this type may result in changes in optical properties of the complexes.

Therefore, the main purpose of this work is to explore the influence of substituents in the diketonate fragment on the properties of the complexes. The most perspective 2-aryl/heteroaryl-1-phenyl-benzimidazoles containing donor/acceptor substituents were used as «antenna» ligands. In addition, a series utilizing 4,4'-dicarboxy-2,2'-bipyridine as an "anchoring" ligand was characterized.

Herein, we present a joint experimental and theoretical study (X-ray, NMR, MS, UV-Vis, CV) of several series of iridium (III) complexes with 2-arylbenzimidazoles and different "anchoring" ligands: (Figure 1). The correlations between structure of ligands and properties of the corresponding complexes were established.



**Figure 1.** The complexes studied in this work

## References

[1] Bezzubov S.I., Zharinova I.S., Khusyainova A.A., Kiselev Y.M., Taydakov I.V., Varaksina E.A., Metlin M.T., Tobohova A.S., Korshunov V.M., Kozyukhin S.A., Dolzhenko V.D. *Eur. J. Inorg. Chem.* **2020**, *34*, 3277–3286

BENZOTHIAZOLE- VS. PYRAZOLE-BASED UNSYMMETRICAL (PCN) PINCER COMPLEXES OF NICKEL(II) AS HOMOGENEOUS CATALYSTS IN ETHYLENE OLIGOMERIZATION

Mikhailov I.K.<sup>1</sup>, Gafurov Z. N.<sup>2</sup>, Bekmukhamedov G. E.<sup>1,2</sup>, Kagilev A. A.<sup>1,2</sup>, Zueva E. M.<sup>2,3</sup>, Rossin A.<sup>4</sup>, Giambastiani G.<sup>4</sup>, Yakhvarov D. G.<sup>1,2</sup>

<sup>1</sup>Kazan Federal University, Alexander Butlerov Institute of Chemistry, Kazan, Russia

<sup>2</sup>Arbuzov Institute of Organic and Physical Chemistry, FRC Kazan Scientific Center, Kazan, Russia

<sup>3</sup>Kazan National Research Technological University, Kazan, Russia

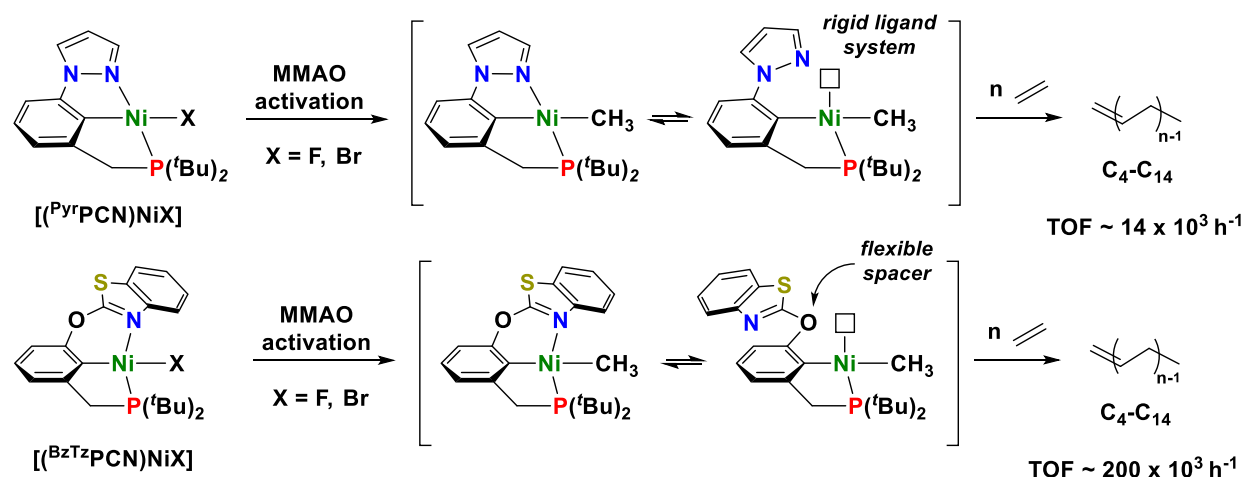
<sup>4</sup>Institute of Chemistry of Organometallic Compounds, Sesto Fiorentino (Florence), Italy

Student

[tiimhaylov@bk.ru](mailto:tiimhaylov@bk.ru)

One of the main tasks of modern sustainable chemistry is the replacement of precious metal catalysts with earth-abundant metal alternatives without loss of catalytic activity. On this regard, nickel complexes have been deserving increasing attention as versatile catalysts for a wide range of organic transformations [1]. However, their catalytic performance greatly relies on the precise design of their organic ligands. Pincer-type ligands with a *mer* tridentate binding mode are highly effective in stabilizing four-coordinated square-planar nickel complexes, which have been prepared and examined in some catalytic processes [2-3].

In this work the nickel complexes  $(^{BzTz}PCN)NiX$  ( $^{BzTz}PC(H)N = 2$ -((di-tert-butylphosphino)methyl)phenoxy)benzo[d]thiazole; X = F, Br) containing the unsymmetrical pincer  $k^3$ -tridentate ligand with an oxo-bridged benzothiazole side-arm (Figure 1) have been tested as homogeneous catalysts in ethylene oligomerization after preliminary activation by Modified Methylaluminoxane (MMAO). They showed high activity in the process (up to  $200 \times 10^3 \text{ mol}_{C_2H_4} \cdot \text{mol}_{Ni}^{-1} \cdot \text{h}^{-1}$ ), with formation of even-numbered olefins (mainly  $C_4$ - $C_{10}$  fractions) as products. The comparison of their performance with the results obtained for more rigid pyrazole-based analogues ( $^{Pyr}PCN)NiX$  ( $^{Pyr}PC(H)N = 1$ -[3-[(di-tert-butylphosphino)methyl]phenyl]-1H-pyrazole; X = F, Br) demonstrates a positive effect stemming from the increased ligand flexibility. Moreover, the activation of  $(^{BzTz}PCN)NiX$  by MMAO was studied by UV-Vis and  $^{31}P$  NMR spectroscopies combined with time-dependent density functional theory (TD-DFT), revealing the formation of Ni-CH<sub>3</sub> species. Finally, DFT calculations performed to explore the mechanism of ethylene oligomerization catalyzed by complexes  $(^{Pyr}PCN)Ni(CH_3)$  and  $(^{BzTz}PCN)Ni(CH_3)$  revealed that the combination of oxo-bridge extra flexibility and reduced N-donor basicity favors dissociation of the N-side arm and its rotation around the bond connecting the two pincer sides. The benzothiazole side-arm remains uncoordinated, generating a vacant coordination site which is a prerequisite for the obtainment of a more active catalyst.



**Figure 1.** Pyrazole- and benzothiazole-based PCN pincer nickel complexes in ethylene oligomerization reaction.

### References

- [1] Gafurov Z.N., Kagilev, A.A., Yakhvarov D.G. et al. *Russ. Chem. Bull.* **2018**, 67, 385–394
- [2] Luconi L., Gafurov Z.N., Yakhvarov D.G. et al. *ACS Omega.* **2019**, 4, 1118-1129
- [3] Gafurov Z.N., Kagilev A.A., Mikhailov I.K., Yakhvarov D.G. et al. *J. Organomet. Chem.* **2020**, 912, 121163

**Acknowledgements.** The authors are thankful to the Russian Government Program of Competitive Growth of Kazan Federal University (Reg. Nr. AAAA- A19-119053190012-8) for performing of catalytic experiments in KFU and to the Government assignment for FRC Kazan Scientific Center of RAS for supporting of the synthesis part.

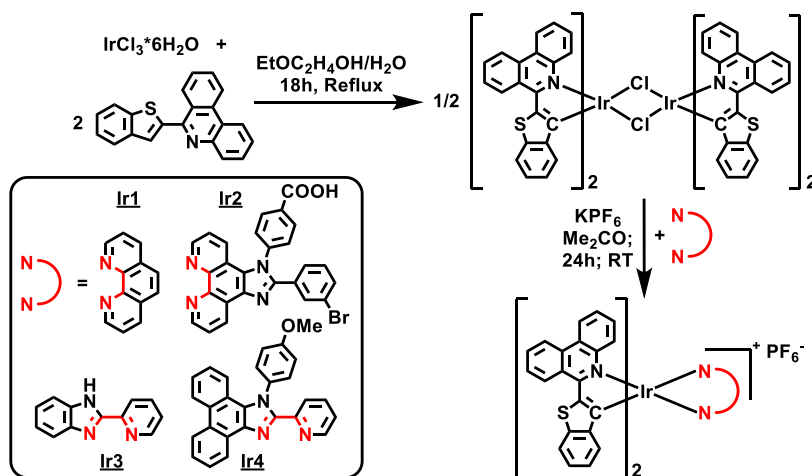


# PHOSPHORESCENT IR(III) COMPLEXES WITH DIFFERENT N^N LIGANDS FOR OXYGEN SENSING

*Mikhnevich V.G.<sup>1</sup>, Kritchenkov I.S.<sup>2</sup>*

<sup>1</sup>Saint Petersburg State University, Saint Petersburg, Russia  
Student  
[st076006@student.spbu.ru](mailto:st076006@student.spbu.ru)

Molecular oxygen is inevitable for all aerobic organisms as it plays the key role in cellular respiration. Hypoxia may be a symptom of serious pathologic processes such as cancer or cardiovascular diseases. Therefore, oximetry (measuring the concentration of oxygen) is very relevant in modern science. The PLIM (phosphorescence lifetime imaging) oximetry is gaining popularity due to its effectiveness and possibility to measure oxygenation at cellular and subcellular level. In this method, phosphorescent transition metal complexes are commonly used as molecular oxygen probes, due to its large Stokes shifts, greater lifetime values and triplet nature of excited states, which results in ability for O<sub>2</sub>-quenching of their emission, as well as spectral and/or time-gated separation of phosphorescence from the autofluorescence of biomolecules.<sup>[1]</sup> Many octahedral Iridium (III) complexes meet such requirements for phosphorescence sensors as high sensibility for oxygen, emission in red or near-infrared (NIR) region, solubility in biological environment, biocompatibility, low cytotoxicity, redox and photobleaching stability.<sup>[2]</sup> In this work, a series of 4 new phosphorescence iridium complexes were synthesized (figure 1).



**Figure 1.** Synthesis of Iridium complexes

The compounds under study were fully characterized by modern methods of analysis. These complexes exhibit effective emission in NIR region with high quantum yields in solution. Study of their emission in aerated and degassed solutions made it possible to choose complex **Ir4** as most effective O<sub>2</sub>-sensor in this series, as it showed the highest response to the presence of O<sub>2</sub>.

## References

- [1] T. Yoshiharaa, Yo. Hirakawa, M. Hosakac, M. Nangakub, S. Tobitaa.. *J. Photochem. Photobiol. C: Photochem. Rev.* **2017**, 30, 71–95
- [2] Youngmin You. *Curr. Opin. Chem. Biol.* **2013**, 17, 699–707

**Acknowledgements.** This work was supported by RSF (grant number 18-73-10021), NMR and ESI-MS analysis were performed using the equipment of the Centers for Magnetic Resonance and for Chemical Analysis and Materials Research (Research Park of St. Petersburg State University).

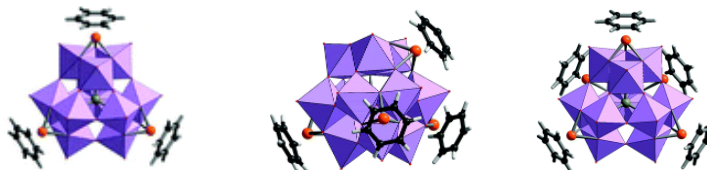
*Mukhacheva A.A.*<sup>1</sup><sup>1</sup>Nikolaev Institute of Inorganic Chemistry of SB RAS, Novosibirsk, Russia

PhD Student

[mukhacheva@niic.nsc.ru](mailto:mukhacheva@niic.nsc.ru)

Polyoxometalates (POM) are of fundamental and applied interest. POMs show catalytic activity, photo- and redox activity, antitumor and antiviral activity. Some of them exhibit properties that are interesting for analytical chemistry, magnetochemistry, and materials science. A special category of POM is made up of complexes with noble metals, since they can provide a synergistic effect in the catalysis of a wide range of reactions.

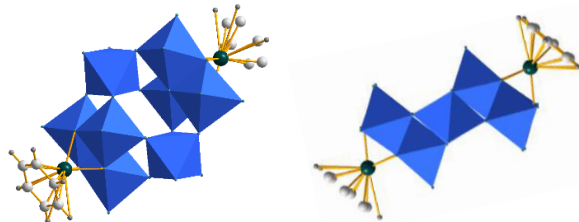
The Ru-containing POMs in this paper were obtained using three different approaches. The first approach involves the rearrangement of the initial POM  $[\text{VNb}_{14}\text{O}_{42}(\text{CO}_3)_2]^{13-}$ , accompanied by the removal of two niobium fragments and the coordination of 3 to 5 organometallic groups  $\{(\text{C}_6\text{H}_6)\text{Ru}\}^{2+}$ . In this case, a mixture of  $[\alpha\text{-}\{(\text{C}_6\text{H}_6)\text{Ru}\}_4\text{VNB}_{12}\text{O}_{40}]^{7-}$  and  $[\alpha\text{-}\{(\text{C}_6\text{H}_6)\text{Ru}\}_3\text{VNB}_{12}\text{O}_{40}]^{9-}$  is formed in an aqueous solution, but only the product with 4 organometallic fragments crystallizes. Chromatographic separation of the reaction mixture of these complexes leads to an unexpected transformation of both particles into  $[\alpha\text{-}\{(\text{C}_6\text{H}_6)\text{Ru}\}_5\text{VNB}_{12}\text{O}_{40}]^{5-}$ . This anion contains five coordinated organometallic groups occupying both triangular and rectangular faces.



**Figure 1.** Structures of polyanions with 3, 4 and 5 organometallic groups  $\{(\text{C}_6\text{H}_6)\text{Ru}\}^{2+}$ .

The second approach to the synthesis is based on the interaction of a monolacunar polyoxoanion with a positively charged  $\{\text{Ru}(\text{NO})\}^{3+}$ , with coordination occurring at the vacancy site. The result is a Keggin-type complex  $[\text{PW}_{11}\text{O}_{39}\{\text{Ru}(\text{NO})\}]^{4-}$ . For the resulting tetrabutylammonium salt, the reactivity was studied: during the photolysis of the solution in acetonitrile, the ligand is replaced by a solvent molecule to form the complex  $[\text{PW}_{11}\text{O}_{39}\{\text{Ru}^{\text{III}}(\text{CH}_3\text{CN})\}]^{4-}$ . Heating the latter with sodium azide leads to a cascade of transformations with the formation of three complexes  $[\text{PW}_{11}\text{O}_{39}\{\text{Ru}^{\text{III}}(\text{N}_3)\}]^{5-}$ ,  $[\text{PW}_{11}\text{O}_{39}\{\text{Ru}^{\text{III}}(\text{N}_4\text{HC-CH}_3)\}]^{4-}$ ,  $[\text{PW}_{11}\text{O}_{39}\{\text{Ru}^{\text{II}}(\text{N}_2)\}]^{5-}$ . The complexes exhibit Red/Ox activity, which is confirmed by electrochemical studies using cyclic voltammetry.

The latter approach, used to obtain Ru-containing POMS, is associated with the self-assembly of polyatomic complexes from the simplest initial building blocks  $[(\text{C}_6\text{H}_6)\text{RuCl}_2]_2$  and  $\text{Na}_2\text{WO}_4$ . The slow evaporation of the reaction solution leads to the crystallization of  $\text{Na}_6\{[(\text{C}_6\text{H}_6)\text{Ru}]_2\text{W}_8\text{O}_{28}(\text{OH})_2\}$ . As a result of a sequential decrease in the pH of the solution of this salt, a number of products with different degrees of protonation crystallize:  $\text{Na}_{5.5}\text{H}_{0.5}\{[(\text{C}_6\text{H}_6)\text{Ru}]_2\text{W}_8\text{O}_{28}(\text{OH})_2\}$ ,  $\text{Na}_5\text{H}\{[(\text{C}_6\text{H}_6)\text{Ru}]_2\text{W}_8\text{O}_{28}(\text{OH})_2\}$ ,  $\text{Na}_3\text{H}_3\{[(\text{C}_6\text{H}_6)\text{Ru}]_2\text{W}_8\text{O}_{28}(\text{OH})_2\}$ ,  $\text{NaH}_5\{[(\text{C}_6\text{H}_6)\text{Ru}]_2\text{W}_8\text{O}_{28}(\text{OH})_2\}$ . Moreover, the difference in the  $\text{Na}^+/\text{H}^+$  ratio affects the parameters of the crystal lattice. The solid product  $\text{Na}_6\{[(\text{C}_6\text{H}_6)\text{Ru}]_2\text{W}_8\text{O}_{28}(\text{OH})_2\}$  has an irreversible Ru(II)/Ru(III) oxidation wave and is active in the electrocatalytic oxidation of methanol.



**Figure 1.** The structure of  $\{[(\text{C}_6\text{H}_6)\text{Ru}]_2\text{W}_8\text{O}_{28}(\text{OH})_2\}^{6-}$ .

Acknowledgements. This work was supported by the Russian Science Foundation (project No 19-73-10027).

# PREPARATION OF ALUMINUM-SUBSTITUTED BARIUM HEXAFERRITE BY SOL-GEL METHOD

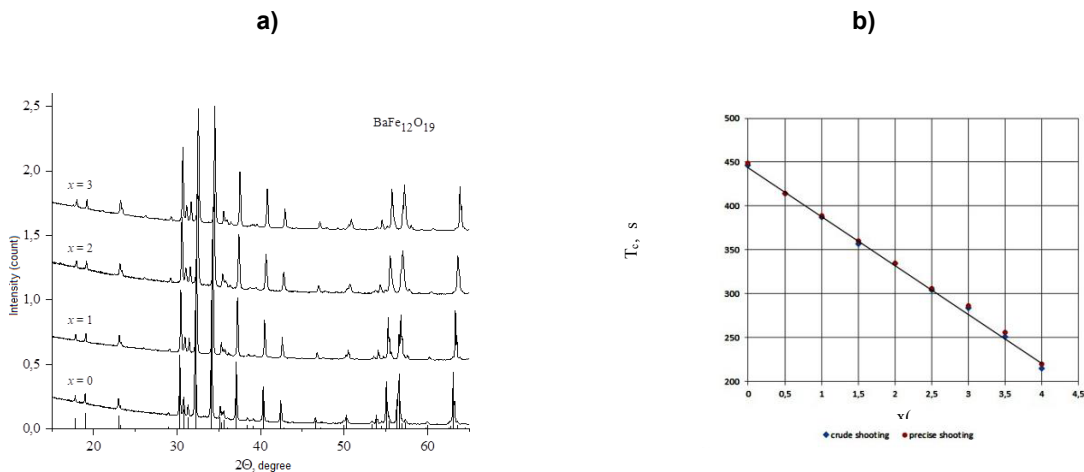
*Mustafina K.E.<sup>1</sup>, Chernukha A.S.<sup>1</sup>*

<sup>1</sup>South Ural State University, Chelyabinsk, Russia  
Student

[karina040801@gmail.com](mailto:karina040801@gmail.com)

Hexaferrites with a magnetoplumbite structure, in particular BaFe<sub>12</sub>O<sub>19</sub>, used as a permanent magnets, components of microwave devices, they also have excellent chemical stability and mechanical strength. For fine tuning of magnetic properties, BaFe<sub>12</sub>O<sub>19</sub>, is ligated with various metals (Al, Bi, Zn, Co, Sn, Ti, B, S), which helps to influence the saturation magnetization. A special place among the substituted hexaferrites is occupied by solid solutions of BaFe<sub>12</sub>O<sub>19</sub>–BaAl<sub>12</sub>O<sub>19</sub> system. Increasing of degree of substitution by aluminum affects the saturation magnetization and has a beneficial effect on the size and weight of microwave devices. Obtaining thin films of aluminum-substituted hexaferrites allows to get prospective materials for a new generation of millimeter-wave devices [1]. In obtaining the pure aluminum-substituted hexaferrite usually used ceramic method [2]. As an alternative to solid-phase synthesis of oxide materials, the following methods are proposed: hydrothermal, microwave, co-deposition and controlled combustion [3]. In our research, for the synthesis of aluminum-substituted barium hexaferrite we used sol-gel auto combustion, or self-combustion method, which allows to reduce the synthesis temperature compared with the ceramic method and obtain monophasic samples.

During the synthesis, a solution of nitrates of the relevant metals with citric acid was prepared. After neutralization (water NH<sub>3</sub> solution) and evaporation of the solution, the resulting mass was heated in a muffle furnace to carry out the self-combustion process and removal of residual carbon. The final sintering of the BaAl<sub>x</sub>Fe<sub>12-x</sub>O<sub>19</sub> samples (x = 0, 1, 2, and 3) was carried out in a muffle furnace with a pre-position temperature controller at 1100°C for 4 hours. The obtained samples were analyzed by XRD, SEM and EDX methods.



**Figure 1. a)** XRD of BaAl<sub>x</sub>Fe<sub>12-x</sub>O<sub>19</sub> (x = 0; 1; 2; 3). **b)** Measure of Cure temperature

As can be seen from the diffractogram, all obtained samples represent a monophasic of barium hexaferrite, the Curie temperature decreases linearly with an increase in the substitution level.

## References

- [1] Ustinov A.B., Tatarenko A.S. *J. Appl. Phys.* **2009**, *105* (2), 023908
- [2] Thongmee S., Osotchan T. *Int. J. Mod. Phys. B* **1998**, *12* (27 & 28), 2847–2855
- [3] Thakur P., Taneja S. *J. Supercond. Nov. Magn.* **2020**, *33* (6), 1569–1584

CARBON COATING PRECURSOR' INFLUENCE ON ELECTROCHEMICAL PROPERTIES OF  
 $\text{LiFe}_{0.5}\text{Mn}_{0.5}\text{PO}_4/\text{C}$

*Nazarov E.E.*<sup>1</sup>, *Fedotov S.S.*<sup>1</sup>, *Antipov E.V.*<sup>1,2</sup>

<sup>1</sup>Skolkovo institute of science and technology, Moscow, Russia

<sup>2</sup>Moscow State University, Moscow, Russia

PhD Student

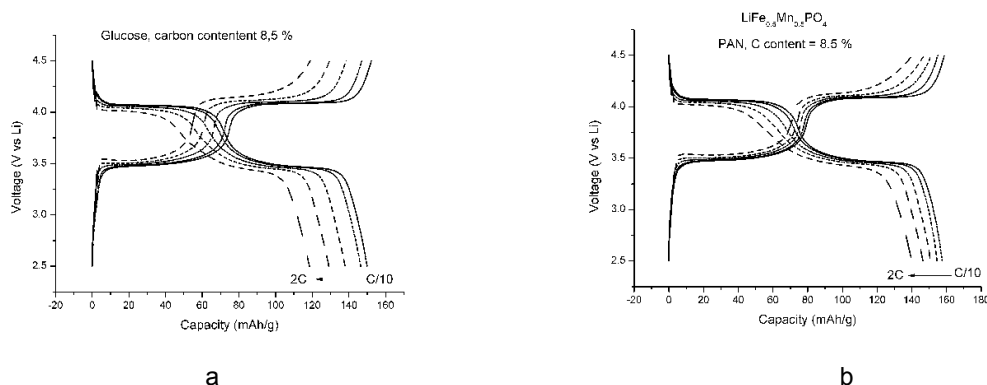
[eugene.nazarov@skoltech.ru](mailto:eugene.nazarov@skoltech.ru)

Triphylite-type cathodes are one of the most attractive materials for application in the fields of electric transportation and large-scale grid storage systems. The reasons are stable and safe operation, long cycling life, and chemical stability. Nevertheless, there are some features that limit the materials' application. Considering  $\text{LiFePO}_4$  as a perfect example of triphylites, its electrochemical performance is severely affected by negligible ionic and electronic conductivity.

Basically, both ionic and electronic conductivity could be increased by d-metal substitution in the triphylite crystal structure, but the effect on electronic transport of the material is not satisfied. Another technique is to apply a carbon coating on the surface of the material particles by carbon precursor decomposition process. These approaches result in the formation of a uniform carbon layer that increases the grain-boundary conductivity significantly. The structure, thickness and uniformity of the formed layer depend on the carbon precursor type as well as on the parameters of the coating process.

Typically, an organic compound (monomer or polymer) is used as a carbon-coating precursor. The most frequently used precursor for LFP technology is glucose which could form a thin (2-4 nm) and uniform carbon layer on the particles' surface [1]. One more precursor that seems promising for not only obtaining the conductive carbon layer, but also for increasing the high C-rate performance is polyacrylonitrile (PAN) [2]. In patent [2] the difference between glucose and PAN was investigated on LFP and a number of polyanion compounds. The main result is that the carbon coating produced from PAN allows to increase discharge capacity at extremely high C-rates by more than 20%.

Therefore, our motivation was to apply the above-mentioned concept to Mn-doped lithium iron phosphate. We performed a set of experiments with different carbon content for both PAN and glucose in order to investigate the carbon precursor effect on the electrochemical performance. The charge-discharge curves for  $\text{LiFe}_{0.5}\text{Mn}_{0.5}\text{PO}_4/\text{C}$  composite depicted in fig. 1 (a,b).



**Figure 1.** Electrochemical performance of  $\text{LiFe}_{0.5}\text{Mn}_{0.5}\text{PO}_4/\text{C}$  for Glucose (a) and PAN (b) as carbon precursors

Analyzing the obtained results one can conclude that using PAN as a carbon precursor, keeping the carbon content constant, makes it possible to significantly boost the discharge capacity value even at low C-rates.

During the presentation the effect of carbon precursor on graphitization degree of the resulting carbon will be discussed as well as on thickness of conductive layer and on charge transfer resistance of the obtained composites.

### References

[1] Jiang W., *RSC Adv.*, **2017**, 7, 44296

[2] Patent RU2732368C1

Acknowledgements. This work was supported by Russian Foundation for Basic Research (Grant# 20-33-90291)

EFFECT OF REACTION CONDITIONS ON THE FORMATION OF MIXED-VALENCE Cu-BASED MOF  
[Cu<sub>4</sub> {1,4-C<sub>6</sub>H<sub>4</sub> (COO)<sub>2</sub> }<sub>3</sub>(4,4'-bipy)<sub>2</sub>]<sub>n</sub>, ITS YIELD AND PHASE PURITY

*Nedelko N.M., Skripkin M.Y.*

Saint Petersburg State University, Saint Petersburg, Russia

Student

[st087489@student.spbu.ru](mailto:st087489@student.spbu.ru)

Chemistry of metal-organic frameworks or MOFs is a growing field of coordination chemistry. Among them compounds with metal-metal bond attribute the special attention because of possible presence of fragments that are unstable under aerobic conditions. One of the example of these compounds is [Cu<sub>4</sub> {1,4-C<sub>6</sub>H<sub>4</sub> (COO)<sub>2</sub> }<sub>3</sub>(4,4'-bipy)<sub>2</sub>]<sub>n</sub> [1] (compound **1**) that represents the stable example of usually unstable compounds with Cu<sup>I</sup> – Cu<sup>II</sup> fragment.

Purpose of this work is to reveal the effect of the concentration of the starting reagents, the duration of synthesis, the composition of the solvent and copper salt anion on the yield and phase purity of **1**.

Synthesis of **1** is described in paper [1]: briefly, equimolar amounts of copper nitrate, terephthalic acid, 4,4'-bipyridine 50% (mass %) EtOH, 24 h solvothermal synthesis (180 °C).

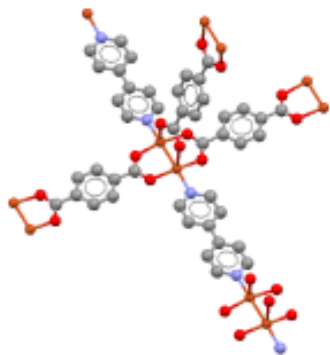
During present study we have analyzed effect of different factors on yield and phase purity of **1**. Upon decrease in the concentration of initial substances from 0.193 mol/L to 0.110, the yield of substance **1** remains at the same level (53%); with a further decrease, the yield falls. Upon decrease in the concentration of the starting substances from 0.193 mol/L to 0.055, the resulting substances is the same in its phase purity; with a further decrease, the formation of impurity phases starts.

To analyze effect of the duration of synthesis we repeat the synthesis with less heating times. As result the pure phase of substance **1** was observed only after 24 hours of synthesis.

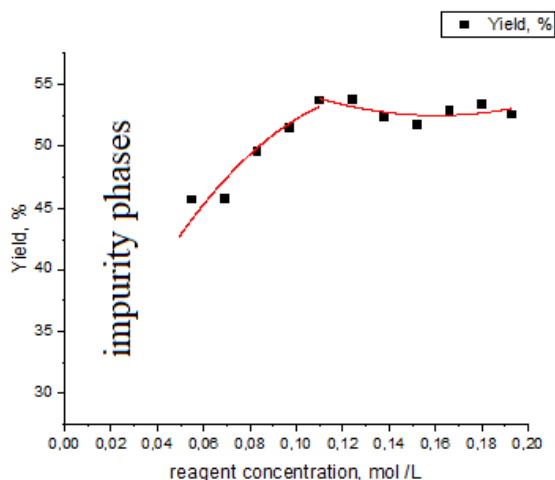
A series of syntheses were carried out with 30, 40, 50, 60, 70% (w / w) EtOH. All substances in this series were found to be of the same phase purity and had similar yields (on average, 53.2%).

We made an attempt to synthesize **1** from CuSO<sub>4</sub>·5H<sub>2</sub>O and Cu(OAc)<sub>2</sub>·2H<sub>2</sub>O. As a result of the synthesis from copper sulfate, compound **1** was obtained, but it was heavily contaminated with an impurity phase. After 24 hours of solvothermal synthesis from copper acetate, only the starting materials were found in the reactor. This can be explained based on stability constants.

As a result, the following synthetic conditions can be proposed, which are optimal: for synthesis, only Cu(NO<sub>3</sub>)<sub>3</sub>·3H<sub>2</sub>O is suitable as a source of Cu<sup>2+</sup>; concentration of starting materials in the range 0.193M - 0.110M, 30% (by weight) EtOH or more, 24 hours, 180 ° C.



**Figure 1.** Structure of **1**.



**Figure 2.** Plot of yield v. reagent concentration.

#### References.

[1] M. F. Lo *et al.*, *J. Am. Chem. Soc.*, **2000**, 122 (26), 6293–6294

Acknowledgements. RFBR is acknowledged for financial support (project 20-33-70025). We would like to express our gratitude to the Resource Center "X-ray Diffraction Research Methods" of the Research Park of St. Petersburg State University for assistance in this work.

A limited number of compounds of one-, three -, and four-valent nickel are known. The trivalent state for the nickel cation is unstable, so most of its compounds are unstable. However, compounds containing  $\text{Ni}^{3+}$  are promising from the point of view of their application as catalysts for different organic reactions [1-3].

Layered double hydroxides (LDH) or hydroxalite-like compounds are basic salts with a specific layered structure. LDH are characterized by a number of interesting properties, including catalytic properties.

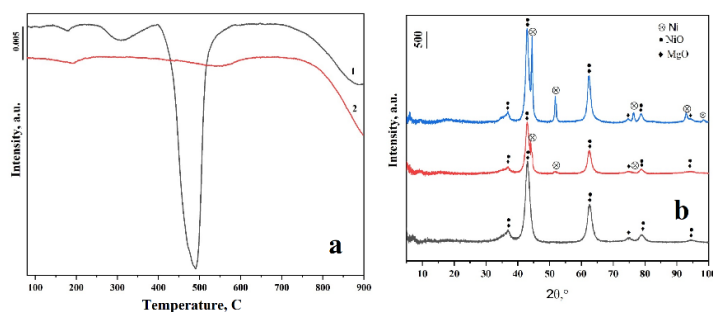
Previously, we obtained a number of layered double hydroxides containing different amounts of nickel cations in an unstable oxidation state of +3 in a brucite-like layer [4]. The synthesized samples were characterized in detail using physicochemical methods of analysis. X-ray photoelectron spectroscopy (XPS) was used to study the chemical state of atoms on the surface of synthesized samples.

LDH containing nickel cations were expected to act as catalysts for the reaction of methanation of carbon dioxide. However, the samples showed poor catalytic activity. Therefore we decided to use the synthesized materials as precursors for the nickel supported catalysts of the same process.

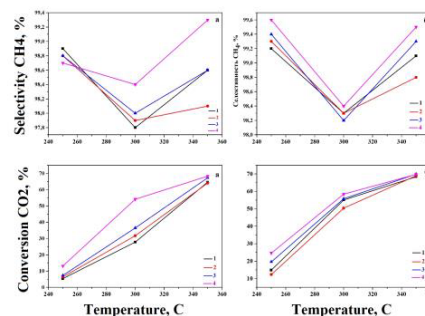
For the preparation of nickel catalysts an important stage was the study of the reducibility of nickel in layered double hydroxides and products of their thermal destruction by temperature-programmed reduction with hydrogen (Fig.1.a). It was shown that nickel in LDH structure started reducing at ca. 700 °C (Fig.1.b.). To characterize the acid-base properties of the surface of mixed oxides obtained after the thermal destruction of LDH, the method of temperature-programmed desorption of carbon dioxide (TPD- $\text{CO}_2$ ) was used.

Samples were pretreated in an 8-channel stationary reactor system with a continuous  $\text{H}_2$ -Ar flow. The hydrogenation of  $\text{CO}_2$  was carried out for samples calcined at 600°C and reduced at 700 and 800°C. As can be seen from the results in Fig 2, the selectivity for  $\text{CH}_4$  and the conversion of  $\text{CO}_2$  increase with an increase in the degree of nickel content in the samples. For the samples reduced at 800°C conversion and selectivity increase.

Thus Mg/AlNi-25 sample reduced at 800°C was proved to be the most effective catalyst precursor for the hydrogenation of  $\text{CO}_2$  with a maximum selectivity for  $\text{CH}_4$  equal to 99.5% and a  $\text{CO}_2$  conversion of ca. 69.8 %.



**Figure 1.** a-TPR- $\text{H}_2$  profiles for Mg/AlNi-25-LDH (1) and Mg/AlNi-25-ox (2); b- XRD patterns of Mg/AlNi-25-ox reduced at different temperatures



**Figure 2.**  $\text{CH}_4$  selectivity and  $\text{CO}_2$  conversion for Mg/AlNi-X-c samples reduced at 700 °C (a) and 800 °C (b): 1- Mg/AlNi-10, 2-Mg/AlNi-15, 3-Mg/AlNi-20, 4-Mg/AlNi-25

### References

- [1] Gong J., Liu J., Wan D., Chen X. *Applied Catalysis A: General*. **2012**, 449, 112–120
- [2] Lin T.J., Meng X., Shi L. *Journal of Molecular Catalysis A: Chemical*. **2015**, 396, 77–83
- [3] Sayed M.E., Abukhadra M.R., Salam M.A., Yakout S.M., Abdeltawab A.A., Aziz I.M. *Energy*. **2019**, 187, 115943
- [4] Ryltsova I.G., Nestroinaia O.V., Lebedeva O.E., Schroeter F., Roessner F. *Journal of Solid State Chemistry*. **2018**, 265, 332–338

Acknowledgements. This work was supported by the DAAD and Ministry of Education and Science of the Russian Federation, project no. 4.13478.2019 / 13.2

VOLUME PROPERTIES OF IODIDE AMMONIUM SOLUTIONS IN MIXED SOLVENTS  
DIMETHYLSULFOXIDE–WATER AT 298.15 K

*Novikova S.N.*<sup>1</sup>, *Starodub A.N.*<sup>1</sup>, *Skorba V. R.*<sup>1</sup>, *Novikov A. N.*<sup>1</sup>,  
*Vasilyov V.A.*<sup>2</sup>, *Solovyov S.N.*<sup>2</sup>, *Rakhmanova P.A.*<sup>2</sup>

<sup>1</sup>Novomoskovsk Institute, Mendeleev University of Chemical Technology, Novomoskovsk, Russia

<sup>2</sup>Mendeleev University of Chemical Technology. Moscow, Russia

Student

[sifin555@gmail.com](mailto:sifin555@gmail.com)

In this work, we continue systematic studies of the thermodynamic properties of solutions based on an aprotic dipolar solvents. [1–3]. Data on the properties of the dimethylsulfoxide (DMSO) –water system [4–5] are evidence of specific interactions of its components with the formation of associates of the composition DMSO·2H<sub>2</sub>O, which should influence the properties of ternary systems. Studies of solutions in mixed solvents is of theoretical and practical interest, because the majority of chemical processes are conducted in such systems.

Mixed solvents were prepared from twice distilled water and DMSO of ch. (pure) grade dried by molecular sieves 4A and twice distilled in a vacuum. The residual content of water in DMSO determined by the Fischer method was taken into account in the preparation of mixed solvents. Ammonium iodide of ch. d. a. (pure for analysis) grade was twice recrystallized from doubly distilled water and absolute ethanol, dried for 3–4 h in air at 343 K and for 48 h in a vacuum at 333 K. The purity of DMSO according to chromatography, and of NH<sub>4</sub>I according to argentometric titration, was no less than 99.9 wt %.

The densities ( $\rho$ ) of solutions of ammonium iodide in DMSO–water mixtures were measured at 298.15 K over the entire range of mixed solvent compositions. The density of solutions was measured on a precision pycnometer with accuracy  $1 \cdot 10^{-5}$  g·cm<sup>-3</sup>.

The data obtained were used to calculate the apparent molar volumes ( $\Phi_v$ ) of ammonium iodide in DMSO-water mixtures. The concentration dependences of the apparent molar volumes are described by the Masson equation

$$\Phi_v = \Phi_v^0 + S_v C^{1/2}, \quad (1)$$

where  $S_v$  is the constant determined experimentally, and  $C$  is the molar concentration.

To determine the standard partial molar volumes of ammonium iodide in DMSO –water mixtures at infinite dilution  $\bar{V}_2^0 = \Phi_v^0$ , the dependences  $\Phi_v = f(m^{1/2})$  were approximated by linear regression equations taking into account the statistical weights of values determined by the error  $\Delta\Phi_v$ . The values obtained for ammonium iodide in DMSO –water mixtures are listed in Table.

**Table 1.** Standard partial molar volumes of ammonium iodide in DMSO–water mixtures at 298,15 K

$X_{\text{DMSO}}$	0,1	0,3	0,5	0,75	0,9	1,0
$\bar{V}_2^0, \text{cm}^3 \cdot \text{mole}^{-1}$	57,9	60,1	55,7	50,4	48,7	47,6

It is noteworthy that the dependences  $\bar{V}_2^0$  have extrema located in the range of ~0.3 mole fractions of DMSO. This character of curves  $\bar{V}_2^0 = f(X_{\text{DMSO}})$  indicates that the specific interaction occurring between the components in a binary DMSO–H<sub>2</sub>O system and leading to the formation of the most stable associates of the DMSO·2H<sub>2</sub>O [4, 5] composition also determines the formation of ternary NH<sub>4</sub>I – DMSO –H<sub>2</sub>O solutions. The presence of the electrolyte does not change the sign of deviations of  $V$  from additivity; rather, it lowers the magnitude of these deviations and, the most dramatic drop occurs in mixtures with  $X_{\text{DMSO}}$  contents 0.3–0.5.

### References

- [1] Novikov A. N., Doronin Ya. I., Rakhmanova P. A. *Russ. J. Phys. Chem. A.* **2018**, 92, 1438-1441
- [2] Novikov A. N., Doronin Ya. I., Vasilev V. A., Rakhmanova P. A. *Russ. J. Phys. Chem. A.* **2018**, 92, 1641-1643
- [3] Novikov A. N., Rassokhina L. Yu. *Russ. J. Phys. Chem. A.* **2013**, A 87, 1318-1322
- [4] Mancera R.L., Chalaris M., Samios J. *J. Molec. Liq.* **2004**, **110**,147-152
- [5] Aznaroz S.V., Mussari L., Postigo M. A. *J. Chem. Eng. Data.* **1993**, 38, 270-276

# CYCLOMETALATED IRIDIUM (III) COMPLEXES WITH 1,2-DIPHENYLPHENANTHROIMIDAZOLE AND DIFFERENT ANCILLARY LIGANDS: SYNTHESIS, STRUCTURE AND PHOTOPHYSICAL PROPERTIES

*Nykhrikova E.V.*<sup>1,2</sup>, *Tatarin S.V.*<sup>1,2</sup>, *Bezzubov S.I.*<sup>1</sup>

<sup>1</sup>Kurnakov Institute of General and Inorganic Chemistry RAS, Moscow, Russia

<sup>2</sup>Moscow State University, Moscow, Russia

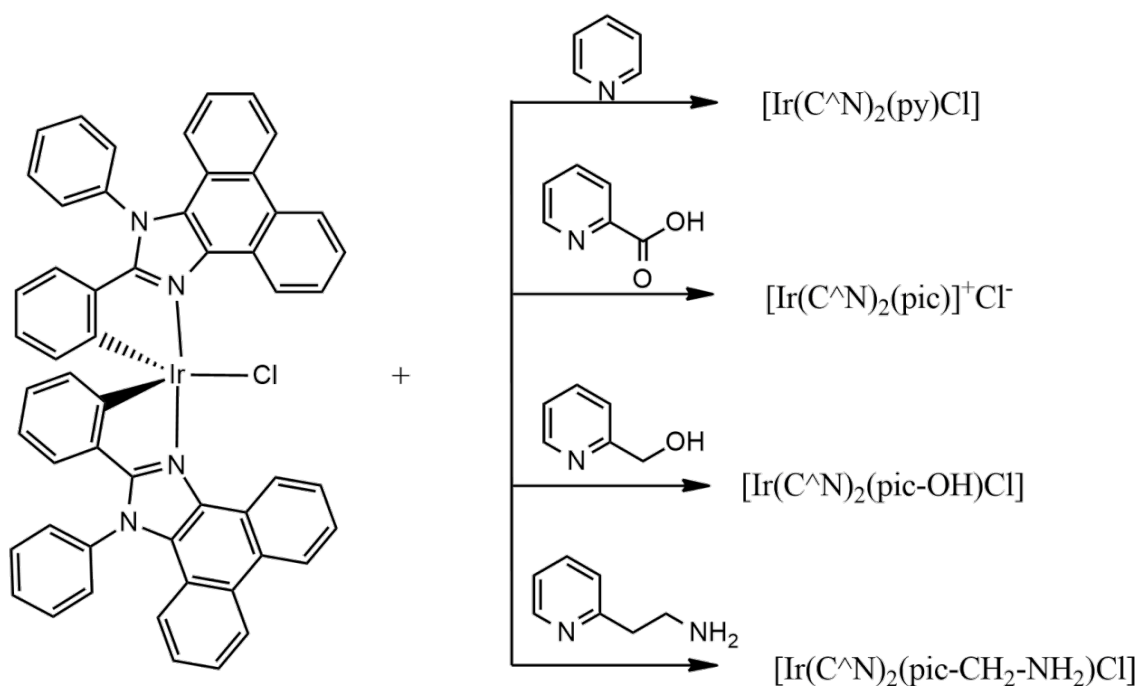
Student

[nihrikova.kate@yandex.ru](mailto:nikhrikova.kate@yandex.ru)

In last 20 years cyclometalated iridium(III) complexes have attracted widespread interest for various applications such as highly efficient photosensitizers, luminescent biological labels, photocatalysts. Ir(III) complexes bearing C<sup>N</sup> and C<sup>C</sup> cyclometalated ligands possess impressive photophysical properties that make them highly desirable for these applications. Combination of these properties with some specific kind of reactivity might expand the application field of such complexes. Unfortunately, there is not so much attention to this type of compounds.

In a previous work, a cyclometalated chloride monomer containing 1,2-diphenylphenanthroimidazoles as cyclometalated ligands was investigated [1]. Although iridium (III) is often considered to be the one of the most inert metal ions which retains octahedral geometry, this compound possessed an extremely rare geometry of trigonal bipyramid. Lability of this compound was explored via single-crystal-to-single-crystal reaction with iodine vapor. Based on this study, we have assumed that iridium-phenanthroimidazole cyclometalated core could be a basis for construction of the complexes with certain extent of lability, which could be applied in medicine and catalysis.

Herein, we present an investigation of reactivity of the abovementioned cyclometalated monomer with different mono- and bidentate ligands: pyridine, picolinic acid, (2-pyridyl)-methanole, 2-(2-Pyridyl)ethylamine. A comprehensive structural and spectroscopical study of the obtained compounds was performed.



**Figure 1.** Reactions performed in this work

## References

[1] S. I. Bezzubov, P. Kalle, A. A. Bilyalova, S. V. Tatarin, V. D. Dolzhenko, *Chem. Eur. J.* **2018**, *24*, 12779



PHASE EQUILIBRIA IN THE TERNARY SYSTEM NaBr-Na<sub>2</sub>MoO<sub>4</sub>-Na<sub>2</sub>WO<sub>4</sub>

*Osipov V.T.<sup>1</sup>, Radchenko A.V.<sup>1</sup>, Sukharenko M.A.<sup>1</sup>, Garkushin I.K.<sup>1</sup>*

<sup>1</sup>Samara State Technical University, Samara, Russia

Student

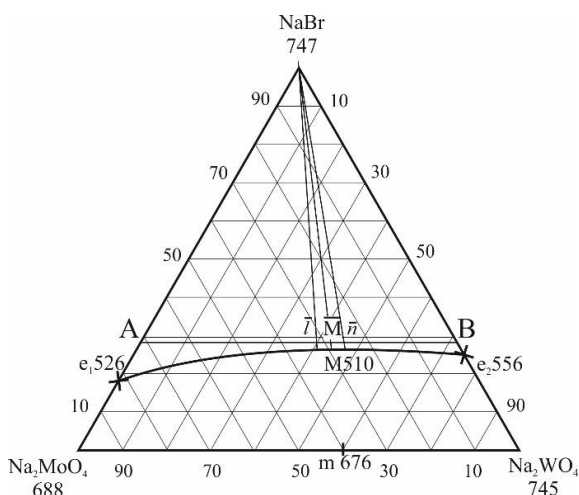
[vld.ospv@gmail.com](mailto:vld.ospv@gmail.com)

The purpose of work - study of phase equilibria in the ternary system NaBr-Na<sub>2</sub>MoO<sub>4</sub>-Na<sub>2</sub>WO<sub>4</sub>. Investigated system consists of two two-component eutectic system – NaBr-Na<sub>2</sub>MoO<sub>4</sub> and NaBr-Na<sub>2</sub>WO<sub>4</sub>, and one system with a continuous series of solid solutions Na<sub>2</sub>Mo<sub>x</sub>W<sub>1-x</sub>O<sub>4</sub> based on sodium molybdate and tungstate with a minimum. The solid solution is formed by the isostructural molybdate and sodium tungstate. Therefore, in a three-component system, the absence of points of invariant equilibria and the presence of only two solid phases – NaBr and Na<sub>2</sub>Mo<sub>x</sub>W<sub>1-x</sub>O<sub>4</sub> – are predicted.

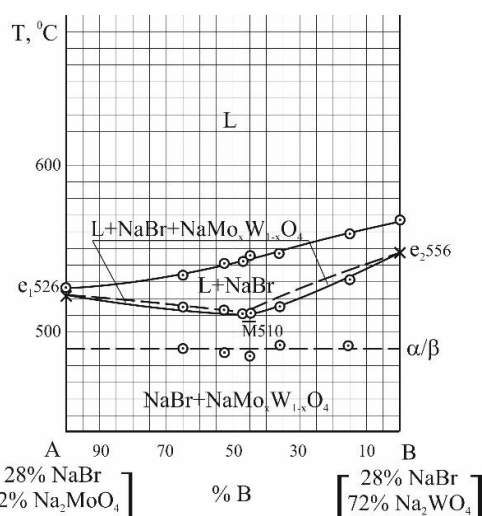
Experimental studies were carried out by the method of differential thermal analysis (DTA) [1-3]. The projection of the phase of the complex in the triangle composition is shown in Figure 1. The polythermal cut AB was selected in the crystallization field of sodium bromide. No tertiary crystallization effects are observed on the T-x-diagram. Therefore, there are two solid phases in the system – NaBr and Na<sub>2</sub>Mo<sub>x</sub>W<sub>1-x</sub>O<sub>4</sub>.

The direction to the minimum point and its melting point are determined (510°C). The composition of the minimum point was found by studying the polythermal cut drawn from the top of sodium bromide through the direction to the minimum NaBr→M→M: 26% (NaBr)<sub>2</sub> + 30% Na<sub>2</sub>MoO<sub>4</sub>+ 44% Na<sub>2</sub>WO<sub>4</sub>.

The bend of the monovariant curve e<sub>1</sub>e<sub>2</sub> was determined by studying a series of polythermal cuts: NaBr→l→l, NaBr→M→M, NaBr→n̄→n. The minimum point corresponds to phase equilibrium: L ⇌ NaBr + Na<sub>2</sub>Mo<sub>x</sub>W<sub>1-x</sub>O<sub>4</sub>. The phase diagram is represented by two crystallization fields - sodium bromide and a continuous series of solid solutions Na<sub>2</sub>Mo<sub>x</sub>W<sub>1-x</sub>O<sub>4</sub>



**Figure 1.** Projection of the phase complex of a three-component system NaBr-Na<sub>2</sub>MoO<sub>4</sub>-Na<sub>2</sub>WO<sub>4</sub> per triangle of compositions



**Figure 2.** T-x-diagram of a polythermal cut AB of a three-component system NaBr-Na<sub>2</sub>MoO<sub>4</sub>-Na<sub>2</sub>WO<sub>4</sub>

**References**

- [1] Garkushin I.K., Ragrina M.S., Sukharenko M.A. *Russ. J. Inorg. Chem.* **2018**. 63 (1), 98-103
- [2] Gamataeva B.Y., Kurbanova S.N., Gasanaliev A.M. et al. *Inorg. Mater.* **2020**. 56 (2), 136-141
- [3] Likhacheva S. S., Egorova E. M., Garkushin I. K. *Russ. J. Inorg. Chem.* **2020**. 65, 1047–1050

Acknowledgements. This work was carried out with financial support from the Ministry of Education and Science of the Russian Federation within the framework of the design part of the state assignment № 0778-2020-0005.

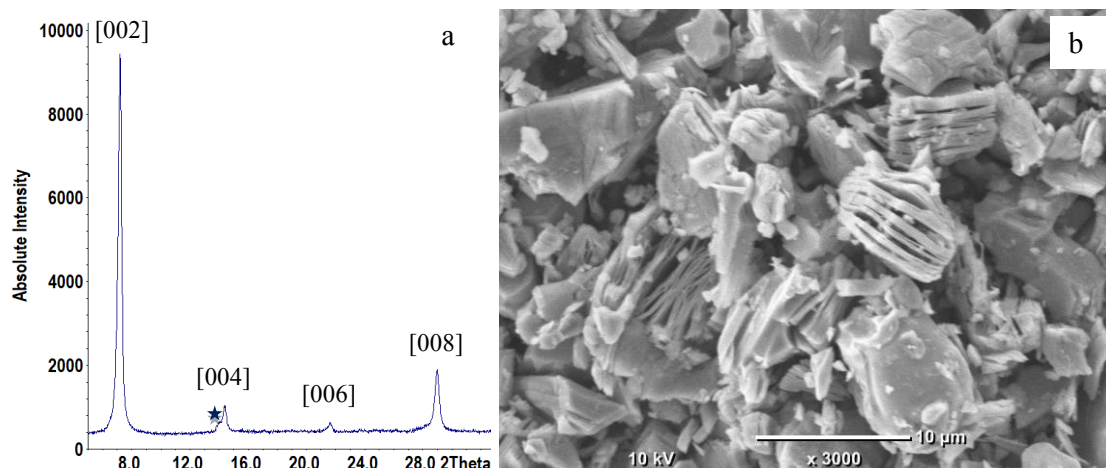
# ADSORPTION OF ORGANIC SOLVENTS ON $Ti_3C_2T_x$ MXENE WITH DIFFERENT SURFACE FUNCTIONALIZATION

*Osipov N.I., Suslova E.V., Savivlov S.V.*

Moscow State University, Moscow, Russia  
PhD student  
[tgphu@mail.ru](mailto:tgphu@mail.ru)

Two-dimensional carbides and nitrides of transition metals, also known as MXenes, are a fast-growing family of compounds that have attracted attention as energy storage materials. Their general formula can be described as  $M_{n+1}X_nT_x$  ( $n = 1-3$ ), where M is a transition metal, X is carbon and/or nitrogen and  $T_x$  is the surface termination groups. Wide range of accessible transition metals and broad opportunities for surface modification provides to MXenes ability to adjust to astounding variety of applications. That's why it is important to understand the influence of different surface groups on the properties of the material.

Performance of energy storage materials are greatly influenced by electrode-electrolyte interaction, which can be tuned by controlling the composition of surface groups. We prepared  $Ti_3C_2T_x$  with different surface functionalization from  $Ti_3AlC_2$  by using different synthesis approaches. Firstly, aqueous solution approach, in which 1M solution of bare  $NH_4HF_2$  and two mixtures of  $NH_4HF_2$  solution with hydrochloric and sulfuric acids were used to remove Al [1]. Secondly, Lewis acid  $NiCl_2$  being used as etching agent was added to a mixture of NaCl and KCl in eutectic ratio at  $750^\circ C$ . MXenes with different contents of -OH, -F and -Cl termination groups were synthesized. Obtained MXenes were characterized by SEM, TEM, XRD and XPS.



**Figure 1.** XRD pattern (a) and SEM picture (b) of MXene, obtained by  $NH_4HF_2$ . Impurity of  $NH_4AlF_4$  marked by star symbol.

Adsorption of acetonitrile, DMSO and hexane on synthesized MXenes were studied by automated multi-vapor gravimetric sorption analyzer DVS Advantage and the influence of the surface composition on the sorption of each of the selected solvents was determined.

## References

- [1] Naguib M., et al. *Adv. Mater.* **2011**, 23, 4248–4253.
- [2] Li Y., et al. *Nat. Mater.* **2020**, 19, 894–899.

Acknowledgements. This work was supported by Russian Foundation for Basic Research (project No 19-03-00713).

CONTROL ON SELF-ORGANISATION IN THE CRYSTALLINE PHASE OF SUPRAMOLECULAR METAL-ORGANIC COMPOUNDS BASED ON (THIA)CALIX[4]ARENE MOLECULAR BUILDING BLOCKS

*Ovsyannikov A.S.*<sup>1</sup>, *Kniazeva M.V.*<sup>1</sup>, *Solovieva S.E.*<sup>2</sup>, *Antipin I.S.*<sup>2</sup>

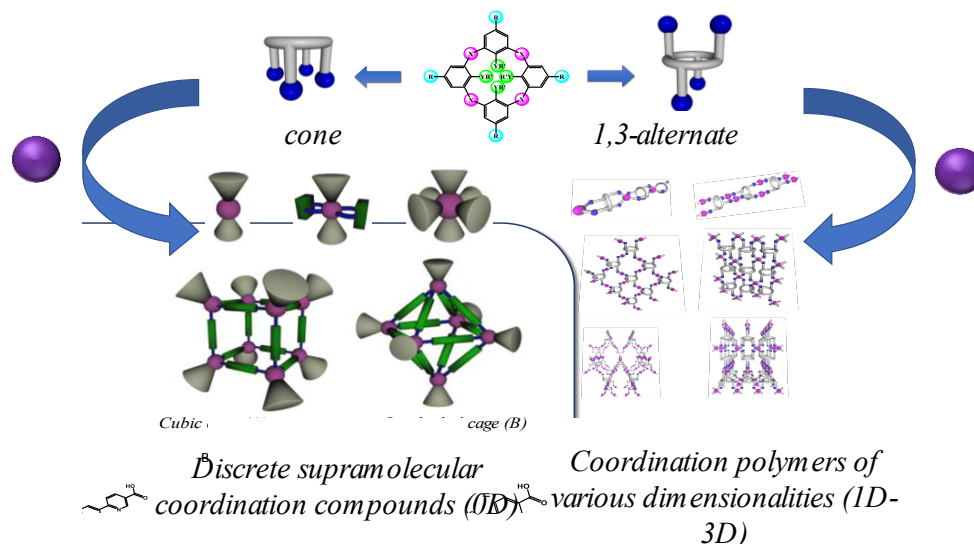
<sup>1</sup> A.E. Arbuzov Institute of Organic and Physical Chemistry, FRC Kazan Scientific Center, Russian Academy of Sciences, Kazan, Russia

<sup>2</sup> Kazan Federal University, Kazan, Russia

Young Scientist

[osaalex2007@rambler.ru](mailto:osaalex2007@rambler.ru)

(Thia)calix[4]arenes represent versatile molecular platform especially adopted for generation of various crystal state coordination compounds displaying various dimensionalities (0D-3D) and functions [1-5]. Depending of the conformation of macrocyclic platform (*cone* or *1,3-alternate*) their interaction with d or f cations may afford the formation of either discrete metal-organic clusters or extended coordination polymers in the crystalline phase exhibiting tunable luminescence and single molecule magnet behavior [6]. Moreover, it was shown that the shape of resulting solid-state supramolecular architectures can be controlled also up by the proper choice of the used auxiliary ligands bearing N/O-donor atoms. Here we report the principles of the rational design of crystalline materials based on the metal-organic compounds obtained using the (thia)calix[4]arenes and their functional derivatives as organic molecular building blocks.



**Figure 1.** (Thia)calix[4]arenes in *cone* and *1,3-alternate* conformations as molecular building blocks for discrete supramolecular complexes as well as 1D-3D coordination polymers formation.

#### References

- [1] Ovsyannikov A.S., Solovieva S.E., Antipin I.S., Ferlay S. *CoordChemRev.* **2017**, *352*, 51-186
- [2] Bi Y., Du S., Liao W., *CoordChemRev.*, **2014**, *276*, 61–72
- [3] Ovsyannikov A.S., Ferlay S., Solovieva S.E., Antipin I.S., Kyritsakas N., Hosseini M. W. *CrystEngComm.* **2018**, *20*, 1130–1140
- [4] Kniazeva M.V., Ovsyannikov A.S., Islamov D.R., Samigullina A.I., Gubaidullin A.T., Dorovatovskii P.V., Solovieva S.E., Antipin I.S., Ferlay S., *CrystEngComm.*, **2020**, *22*, 7693-7703
- [5] Ovsyannikov A.S., Kniazeva M.V., Islamov D.R., Samigullina A.I., Gubaidullin A.T., Solovieva S.E., Antipin I.S., Ferlay S., *Crystals.*, **2020**, *10*, 364
- [6] Ovsyannikov A.S., Khariushin I.V., Solovieva S. E., Antipin I. S., Komiya H., Marets N., Tanaka H., Ohmagari H., Hasegawa M., Zakrzewski J. J., Chorazy S., Kyritsakas N., Hosseini M. W., Ferlay S. *RSC Adv.*, **2020**, *10*, 11755-11765.

Acknowledgements. This work was supported by the Russian Science Foundation (project No 19-73-20035).

POST-SYNTHETIC ICLICK MODIFICATIONS OF Pt(II) COMPLEX: UNUSUAL REACTIVITY AND PHOTOPHYSICAL PROPERTIES

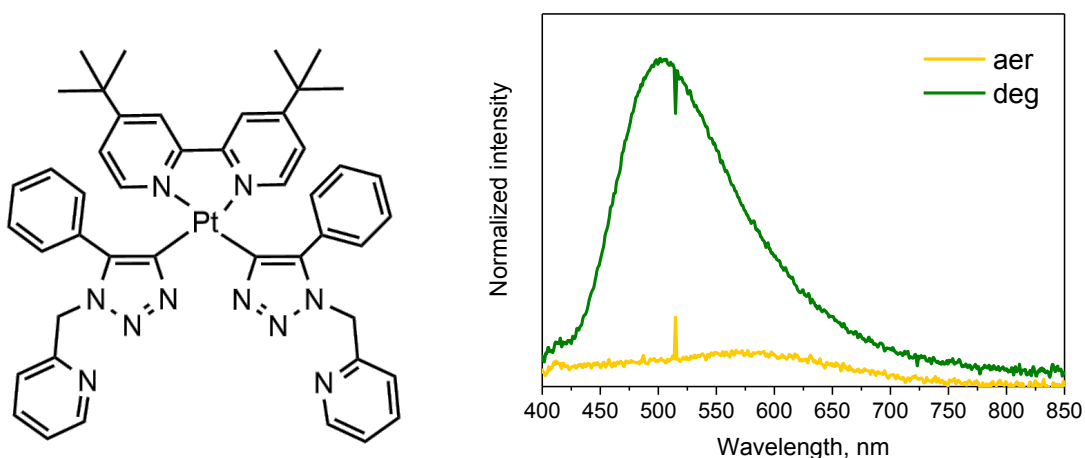
*Paderina A.V.*<sup>1</sup>, *Abramova E.O.*<sup>1</sup>

<sup>1</sup>Saint Petersburg State University, Saint Petersburg, Russia  
PhD Student  
[ksaniasha@list.ru](mailto:ksaniasha@list.ru)

Post-synthetic modification (PSM) offers a convenient way for additional functionalization of coordination compounds. One of the most promising PSM methods is "iClick" (inorganic click) reactions. This method of synthesis allows to introduce the 1,2,3-triazolate ring in the structure of complexes. Varying the azide precursor, one can assemble an additional coordination position on the periphery of the ligand environment.

Post-functionalized triazolate Pt(II) square-planar complexes were already investigated in literature [1,2]. The authors point out the emission enhancement caused by triazolate moiety. Interestingly, Yam et.al. reported [Pt(5,5'-Me<sub>2</sub>bpy)(C≡CPh)<sub>2</sub>] modification, yielding exclusively single cycloaddition product. The second acetylene moiety remained unreacted even in the presence of azide excess.

In contrast to the literature data, we have synthesized the novel bis-triazolate complex of Pt(II) by post-synthetic modification of bis-acetylide precursor. The target compound emits in visible range with emission enhancement in deaerated solution. NMR, mass spectra and XRD data are reported, as well as optical and photophysical measurements. It has been found that the pyridine sites stay active and their donor properties are enough to be reversibly protonated with no destruction of the complex.



**Figure 1.** On the left: structure of [Pt(dtbp)(i-click)<sub>2</sub>].  
On the right: Normalized emission spectra for aerated and degassed solutions of [Pt(dtbp)(i-click)<sub>2</sub>]

#### References

- [1] K. Peng et al. *Inorg. Chem.* **2019**, *58*, 17, 11508  
[2] Y. Li et al. *Chem. Eur. J.* **2014**, *20*, 13710

**Acknowledgements.** The authors greatly appreciate financial support from the Russian Science Foundation, grant 21-13-00052. The work was carried out using equipment of Centres for Magnetic Resonance, for Chemical Analysis and Materials Research, and X-ray Diffraction Centres (Research Park of St.Petersburg State University).

# EFFECT OF REACTION CONDITIONS ON THE COMPOSITION AND STRUCTURE OF MOF'S BASED ON CADMIUM TRIMESATE

*Parshina E.K., Skripkin M.Y., Kutuzov Y.A.*

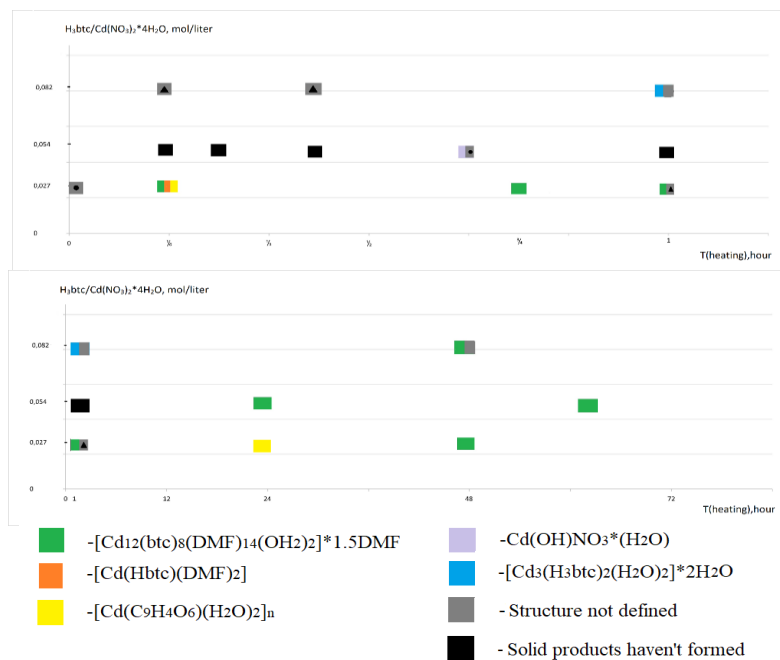
Saint Petersburg State University, Saint Petersburg, Russia

Student

[st085098@student.spbu.ru](mailto:st085098@student.spbu.ru)

Metal-organic frameworks or MOFs are a relatively new class of crystalline compounds that attract the attention of researchers due to their high porosity and a great variety of structures. A lot of data are available concerning the effect of the temperature of the synthesis, solvent composition, concentration of the reagents etc. on the structure formed in the system, whereas the effect of synthesis duration on MOFs compositions is less studied.

The formation of five different compounds was found for the system  $\text{Cd}(\text{NO}_3)_2\text{-H}_2\text{O-H}_3\text{BTC-DMF}$  depending on the heating time of the reaction mixture and concentration of reagents. The results obtained earlier by A.D. Burrows were not fully reproduced. The results obtained enable us to create a phase diagram for this system at  $95^\circ\text{C}$  (Fig. 1).  $[\text{Cd}_{12}(\text{btc})_8(\text{DMF})_{14}(\text{OH}_2)_2]\cdot 1.5\text{DMF}$  was found the most thermodynamically stable phase under the considered conditions. The high variability of the resulting structures was explained based on the HSAB theory.



**Figure 1.** Product – heating time diagram for the system  $\text{Cd}(\text{NO}_3)_2 - \text{H}_2\text{O} - \text{H}_3\text{BTC} - \text{DMF}$ , synthesis temperature –  $95^\circ\text{C}$ .

## References

[1]-Burrows A. D. *Inorg. Chim. Acta.* **2011.** 1 (366), 303–309.

Acknowledgements. RFBR is acknowledged for financial support (project 20-33-70025). We would like to express our gratitude to the Resource Center "X-ray Diffraction Research Methods" of the Research Park of St. Petersburg State University for assistance in this work.

# TRANSITION METAL COMPLEXES WITH IMINOBENZOQUINONE-TYPE LIGANDS: THERMOCHEMICAL PROPERTIES AND PHOTOVOLTAIC INVESTIGATIONS

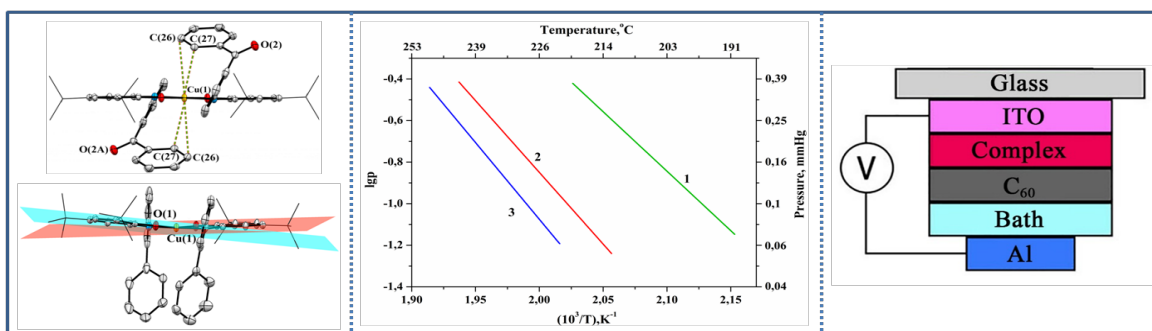
*Pashanova K.I., Lazarev N.M., Kukinov A.A., Piskunov A.V.*

G.A. Razuvaev Institute of Organometallic Chemistry, Russian Academy of Sciences, Nizhny Novgorod, Russia  
Young Scientist  
[pashanova@iomc.ras.ru](mailto:pashanova@iomc.ras.ru)

A series of well-defined transition metal (Cu, Ni, Co) complexes [1-4] on the base of bulky functionalized *o*-iminobenzoquinone-type ligands are in the focus of this work. Coordination compounds under investigation can be separated as two related rows, because two *o*-aminophenols with  $-\text{Ph}-\text{C}(\text{O})\text{Ph}$  additional functions and extended  $\pi$ -systems were used. All metal complexes are distinguished by the square-planar/distorted square-planar coordination environment (Fig.1, left), but display the discrepancies in the location of  $-\text{Ph}-\text{C}(\text{O})\text{Ph}$  groups and in the crystal packing.

All coordination compounds were studied in the point of view of their thermochemical characteristics. In particular, an attention was paid to the issue of thermal stability of the metal complexes, their phase transformations, and the parameters of the sublimation process (enthalpy and entropy of sublimation, composition of the vapor phase, temperature dependences of saturated vapor pressure). So, it was observed how the changes in the nature of ligands influence on the values of sublimation characteristics and the vapor phase composition of metal complexes. The possibility of applying in the photovoltaic devices was also tested.

According to the mass-spectrometry data, there were no other ions with masses greater than a molecular ion in the case of all metal complexes. The temperature dependencies of the vapor pressure of complexes (Fig.1, middle) were measured by the Knudsen effusion method in the temperature interval at 165-250°C. It was shown that the  $\text{Cu}^{\text{II}}$  compounds are characterized by the lowest values of enthalpy of sublimation (103.2 and 109.5 kJ/mol) in contrast to  $\text{Co}^{\text{III}}$  and  $\text{Ni}^{\text{II}}$  analogues (123.5 and 132.1 kJ/mol; 126.7 and 138.4 kJ/mol, respectively). Moreover,  $\text{Cu}^{\text{II}}$  complexes demonstrate the lowest temperature interval of sublimation.



**Figure 1.** Molecular structures of  $\text{Cu}^{\text{II}}$  complexes (left); dependencies of vapor pressure for the  $\text{Cu}^{\text{II}}$  (1),  $\text{Co}^{\text{III}}$  (2);  $\text{Ni}^{\text{II}}$  (3) complexes with  $-\text{C}(\text{O})\text{Ph}$  groups (middle); layer configurations in a photovoltaic cell (right).

To study the photovoltaic properties, we fabricated photovoltaic cells with the ITO/complex (35 nm)/ $\text{C}_{60}$  (35 nm)/Bath (8 nm)/Al configuration (Fig. 1, right). Cells with a working area of 25  $\text{mm}^2$  were irradiated with a solar simulator AM 1.5 G with a power of 100  $\text{mW}/\text{cm}^2$ , as a result of which it was possible to obtain the values of the open circuit voltage and short-circuit current equal to 85 mV and 16  $\mu\text{A}$  (for  $\text{Ni}^{\text{II}}$  complex with  $-\text{Ph}$  groups), 135 mV and 25  $\mu\text{A}$  (for  $\text{Ni}^{\text{II}}$  complex with  $-\text{C}(\text{O})\text{Ph}$  groups). Complexes of  $\text{Co}^{\text{III}}$  and  $\text{Cu}^{\text{II}}$  showed significantly lower values of about 10 mV and  $<0.01 \mu\text{A}$  (measurement accuracy of instruments), and for the  $\text{Cu}^{\text{II}}$  compound during thermal spraying-condensation, partial or complete decomposition with metal precipitation was observed. In general, it was shown that the complexes of described type can be used in the photovoltaic devices, and a further molecular design is an actual issue for the improvement of photovoltaic characteristics.

## References

- [1] Piskunov A. V., Pashanova K. I., Bogomyakov A. S., et al. *Polyhedron* **2016**, *119*, 286-292.
- [2] Piskunov A. V., Pashanova K. I., Bogomyakov A. S., et al. *Dalton Trans.*, **2018** *47*, 15049-15060.
- [3] Piskunov A. V., Pashanova K. I., Ershova I. V., et al. *Russ. Chem. Bull.* **2019**, *68*, 757-769.
- [4] Piskunov A. V., Pashanova K. I., Bogomyakov A. S., et al. *Polyhedron* **2020**, *186*, 114610.

Acknowledgements. The work was carried out with the support of a grant from the President of the Russian Federation for young scientists - candidates of sciences MK-3402.2021.1.3.

# LIGHT-SWITCHABLE ORGANOGOLD(I) COMPOUNDS AS MODEL OBJECTS OF NEW MOLECULAR MACHINE ELEMENTS

*Petrovskii S.K., Grachova E.V.*

<sup>1</sup>Institute of Chemistry, Saint Petersburg State University, Saint Petersburg, Russia  
Postdoc researcher  
[s.petrovsky@spbu.ru](mailto:s.petrovsky@spbu.ru)

Molecular systems and assemblies able to stimuli-responsive structural transformations are of great interest of research due to the far-reaching perspective applications including the development of perspective smart materials, molecular machines, sensing materials. The ability of azobenzene fragment to undergo reversible light-induced cis-trans transformations is well known and is widely utilized in a variety of applications concerning the design and synthesis of organic and organometallic photochromic materials [1-6].

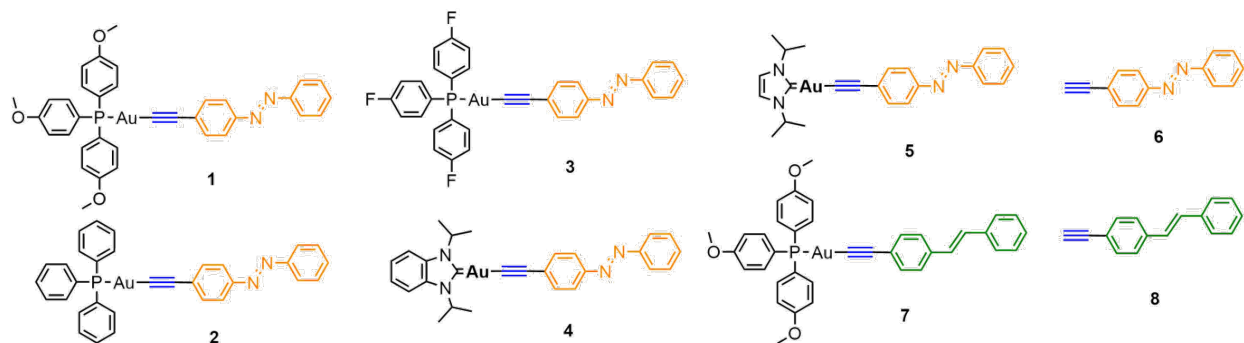
It is well known that incorporation of gold(I) center in the organometallic unit leads to significant changes of electronic structure due to the mixing of molecular orbitals of heavy atom and organic fragment. It leads to dramatic changes in physical (first of all, photophysical ones) properties of the systems and realizations of rich luminescent properties. However, the combination of gold(I) center with azobenzene photochromic moieties still have been rarely implemented in the literature [4].

Also no attention has been paid to the theoretical and experimental evaluation of the influence of organogold centers to electronic structure as well as physico-chemical properties of the organogold-azobenzene hybrid assemblies. Thereby, the understanding of fundamental aspects of Gold(I) influence to the behavior of the hybrid systems is still an urgent task, and in should be critically important for the rational molecular design of the smart functional materials.

In the present work, we report the synthesis, characterization and investigation of photophysical and photochemical characteristics of the series of organogold(I) compounds bearing azobenzene photoisomerizable unit covalently bound to gold(I) center via acetylene function (1-5, Figure 1). The photochromic behavior of the complexes is compared with the ethynylazobenzene (6, Figure 1).

For the comparison, alkynyl phosphine complex (7, Figure 1) bearing stilbene moiety (another efficient photoisomerizable group) at the alkynyl ligand has been also synthesized and investigated.

The results obtained demonstrate the ability of organogold moieties to affect the photochromic properties of azobenzene photo-switchers and could be helpful for further works aimed at the molecular design of advanced materials.



**Figure 1.** Organogold complexes bearing azobenzene (1-5) and stilbene (7) photochromic moieties and corresponding acetylenes (6,8).

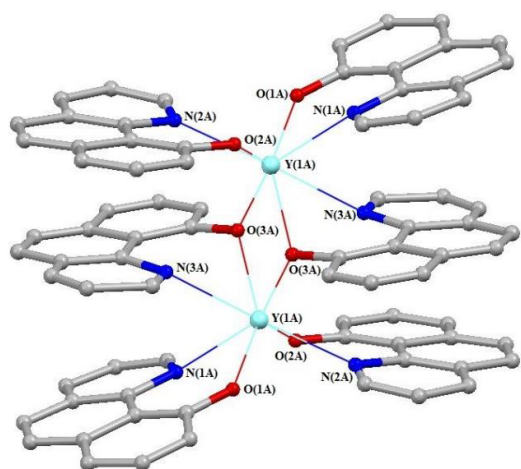
## References

- [1] Segarra-Maset, M. D.; Van Leeuwen, P. W. N. M.; Freixa, Z. *Eur. J. Inorg. Chem.* **2010**, *14*, 2075–2078.
- [2] Cabré, G.; Garrido-Charles, A.; Moreno, M.; Bosch, M.; Porta-de-la-Riva, M.; Krieg, M.; Gascón-Moya, M.; Camarero, N.; Gelabert, R.; Lluch, J. M.; Busqué, F.; Hernando, J.; Gorostiza, P.; Alibés, R. *Nat. Commun.* **2019**, *10* (1)
- [3] Beharrya A. A. and Woolley G.A. *Chem. Soc. Rev.*, **2011**, *40*, 4422-4437
- [4] Hau-San Tang, Nianyong Zhu, and Vivian Wing-Wah Yam. *Organometallics*, **2007**, *26* (1), 22–25
- [5] H. Nishihara. *Coord. Chem. Rev.* **2005**, *249* (13-14), 1468–1475
- [6] Kunfi, A.; Bernadett Vlocskó, R.; Keresztes, Z.; Mohai, M.; Bertóti, I.; Ábrahám, Á.; Kiss, É.; London, G. *Chempluschem* **2020**, *85* (5), 797–805.

**Acknowledgements.** This work was supported by the Russian Science Foundation, project 21-13-00052. The studies were performed using the equipment of Centres for Magnetic Resonance, for Chemical Analysis and Materials Research, and Computer Centre (Research Park of St. Petersburg State University).

G. A. Razuvaev Institute of Organometallic Chemistry of Russian Academy of Sciences, Nizhny Novgorod,  
Russia  
Student  
[spqrz16968@gmail.com](mailto:spqrz16968@gmail.com)

Complexes of rare earth metals with 8-oxyquinoline ligands have excellent photo- and electroluminescent properties, which allows them to be used as emission layers in OLED devices [1]. The analogue of this ligand with the extended  $\pi$ -system is 10-hydroxybenzoquinoline. The oxybenzoquinoline complexes of beryllium and zinc have shown high quantum efficiency of electroluminescence and remarkable thermal stability, making them promising materials for OLED development [2]. Until now, complexes of rare earth metals with oxybenzoquinoline ligands have not been obtained.



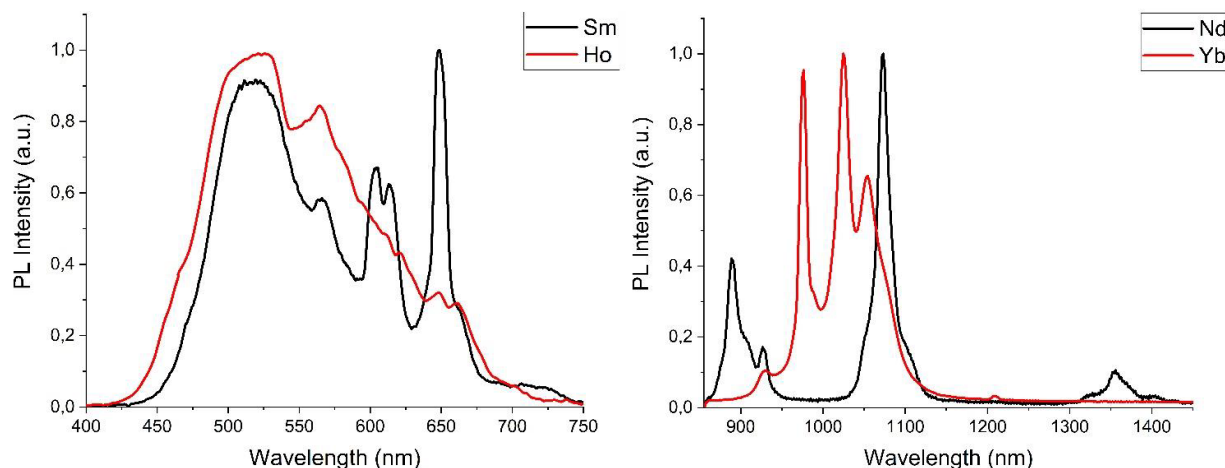
**Figure 1.** Molecular structures of  $[Y(BQ)_3]_2$ .

In search of new effective fluorophores, a set of compounds  $Sc(BQ)_3$  and  $[Ln(BQ)_3]_2$  ( $Ln = Y, Nd, Sm, Eu, Gd, Tb, Ho, Er, Tm, Yb$ ;  $(H(BQ) = \text{benzo}[h]\text{quinolin-10-ol})$ ) were synthesized by exchange reaction of respective (trimethylsilylamide)lanthanide with  $H(BQ)$  in DME solution.

According to X-ray analysis, the  $[Y(BQ)_3]_2$  complex is a dimer (Fig. 1), in contrast to the previously obtained three-nuclear complex with the 8-hydroxyquinoline ligand  $[YQ_3]_3$  [1].

The PL spectra of the obtained complexes contain intense ligand-centered ( $Sc, Y, Gd, Tb, Tm$ ) and metal-centered emission bands, both in the visible ( $Sm, Eu, Ho$ ) and in the NIR range ( $Nd, Er$  and  $Yb$ ). The electroluminescent properties of the obtained complexes were studied in three-layer model devices ITO / TPD / complex / BATH / Yb. The  $Sc$  and  $Y$  complexes exhibit efficient ligand-centered emission in

the form of a broad band in the 510-610 nm range. The EL intensity of the  $Sc(BQ)_3$  complex is comparable to the best results observed for scandium complexes with other organic ligands.



**Figure 2.** Normalized PL spectra of the solid samples of  $Sm, Ho, Nd$  and  $Yb$  complexes at the room temperature ( $\lambda_{ex} 405 \text{ nm}$ ).

#### References

- [1] Baranov E. V., Fukin G. K., Balashova T. V., Pushkarev A. P., Grishin I. D., Bochkarev M. N. *Dalton Trans.* **2013**, 42, 15699–15705  
[2] Guo Z., Dong Z., Zhu R., Jin S., Liu B. *Spectrochim. Acta, Part A* **2007**, 68A(2), 337-340

Acknowledgements. This work was supported by the Russian Science Foundation (project No 20-73-10115)



# SYNTHESIS OF *CLOSO*-BORATE ANION DERIVATIVES WITH TRIPHENYLPHOSPHINE COMPLEXES OF METALS

*Ponkrashina S.S.*<sup>1</sup>, *Matveev E.Yu.*<sup>1,2</sup>, *Zhizhin K.Yu.*<sup>1,2</sup>

<sup>1</sup> MIREA – Russian Technological University, Moscow, Russia

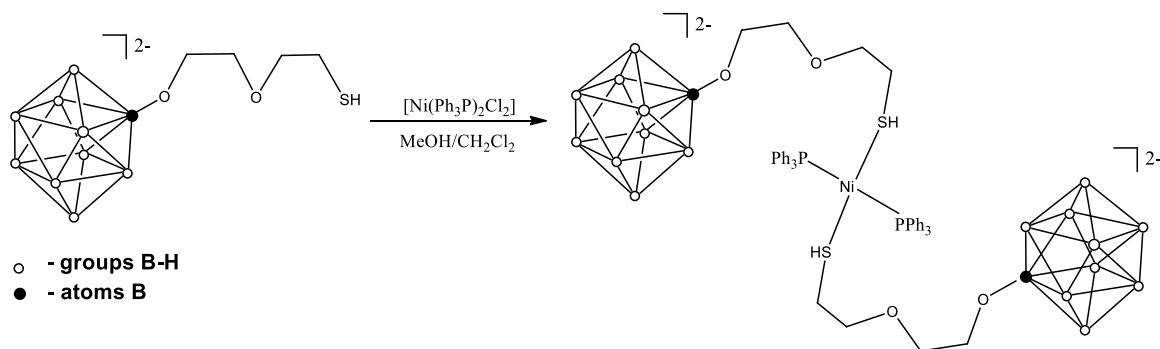
<sup>2</sup> Kurnakov Institute of General and Inorganic Chemistry, Russia

Student

[cat1983@yandex.ru](mailto:cat1983@yandex.ru)

Boron cluster anions  $[B_nH_n]^{2-}$  ( $n = 10, 12$ ) are a class of three-dimensional inorganic structures characterized by thermal stability, resistance to oxidants, and the ability to replace *exo*-polyhedral hydrogen atoms with various functional groups [1-2]. On the basis of boron cluster anions and their derivatives, various complex compounds can be obtained, in which *closo*-borate anions can be located both in the outer sphere and be bound to the complexing agent M for three-center M-H-B interactions. Coordination compounds with ligands based on boron clusters can act as drugs with combined action for  $^{10}B$  neutron capture therapy [3-4].

Our studies have shown that the interaction of *closo*-decaborate anion derivatives with pendant functional groups ( $[B_{10}H_9O(CH_2)_2O(CH_2)_2SH]^{2-}$ ,  $[B_{10}H_9O(CH_2)_2O(CH_2)_2OH]^{2-}$ ,  $[B_{10}H_9O(CH_2)_2O(CH_2)_2SCN]^{2-}$ ,  $[B_{10}H_9O(CH_2)_2O(CH_2)_2NO_2]^{2-}$  etc.) with triphenylphosphine complexes of metals ( $[Ni(Ph_3P)_2Cl_2]$ ,  $[Cu(Ph_3P)_3I]$ ,  $[Co(Ph_3P)Cl]$  etc.) in an organic solvent medium, boron-containing complex compounds are formed, in which the boron cluster can be included both in the inner sphere and in the outer one. The use of triphenylphosphine metal complexes as starting compounds makes it possible to avoid the formation of by-products - complex compounds of metals with a solvent, and also makes it possible to relatively easily obtain coordination-saturated target boron-containing complexes.



**Figure 1.** Synthesis of complex compounds based on *closo*-decaborates with pendant functional groups (by the example of the anion  $[B_{10}H_9O(CH_2)_2O(CH_2)_2SH]^{2-}$ )

The developed method of synthesis makes it possible to vary the pendant functional groups and obtain complex compounds with a wide range of triphenylphosphine metal complexes. The obtained boron-containing complex compounds can be promising for use as drugs of combined action in  $^{10}B$ -NCT of malignant tumors.

## References

- [1] Bregadze V.I., Sivaev I.B., Lobanova I.A., *Appl. Radiat. Isot.*, **2009**, 67, S101.
- [2] Barth R.F., *Appl. Radiat. Isot.*, **2009**, 67, S3.
- [3] Moss R.L., *Appl. Radiat. Isot.*, **2014**, 88, 2.
- [4] R. F. Barth, MGraca H. Vicente, O. K. Harling, W. S. Kiger, K. J. Riley, P. J. Binns, F. M. Wagner, M. Suzuki, T. Aihara, I. Kato and S. Kawabata, *Radiat. Oncol.*, **2012**, 7, 146

THERMODYNAMIC DESCRIPTION OF EXTRACTION AND SORPTION EQUILIBRIUM IN THE PRODUCTION OF LIGHT AND MEDIUM REM FROM COMPLEX-SALT SOLUTIONS

*Ponomareva M.A.<sup>1</sup>, Cheremisina O.V.<sup>1</sup>, Mashukova Yu.A.<sup>1</sup>*

<sup>1</sup>Saint Petersburg Mining University, Saint Petersburg, Russia  
Young Scientist

[ponomareva\\_ma@pers.spmi.ru](mailto:ponomareva_ma@pers.spmi.ru)

Individual rare earth metals (REM) can be obtained along the way during the processing of various types of raw materials using nitric acid and sulfuric acid technologies for processing concentrates containing not more than 1 mass. %. In the processes of ore processing, technological solutions of a complex composition are formed. Sorption methods [1] and extraction methods [2] are among the most effective methods for the extraction and separation of REM from solutions of various compositions. In connection with the use in the solvent extraction of organic extractants that have high toxicity and fire-formation of explosive mixtures, actual use solid phase extraction sorbents.

When carrying out thermodynamic calculations, various mathematical models are used, which are reduced to the reduction of sorption or extraction isotherms to linear forms. In this work, a thermodynamic description of sorption and extraction isotherms was carried out using the model, based on the linearization active masses law, which was modified for the ion exchange equations.

The process of extraction of cerium from nitric acid solutions in the form of anionic complexes with Trilon B (EDTA)  $[Ce(EDTA)]^-$  on anionite and from sulfate solutions in the form of anionic sulfate complexes  $[Ce(SO_4)_2]^-$  on anion exchanger, and europium phosphate from solution in the form of cationic complexes  $[Eu(H_2PO_4)]^{2+}$  have been studied.

To study the sorption extraction of cerium, we used the Chinese-made D-403 anion exchanger, which was converted into a sulfate or nitrate form. For the extraction process, a sorbent obtained by copolymerization of D2EHPA in a mixture with styrene and divinylbenzene, produced by the Smoly Group of Companies, Moscow, was used.

The ion exchange equations and linear forms of the active masses law, which were obtained after a mathematical transformation, have the following form:

$R[NO_3] + [Ce(EDTA)]^- \leftrightarrow R[Ce(EDTA)] + NO_3^-$	$\frac{1}{q_{CeTr}} = \frac{1}{q_\infty} + \frac{[NO_3^-] \cdot \gamma_{\pm NaNO_3}^2}{K \cdot q_\infty \cdot [Ce(EDTA)]^- \cdot \gamma_{\pm NaCeTr}^2}$
$3R_2[SO_4^{2-}] + 2[Ce(SO_4)_2]^- \leftrightarrow 2R_3[Ce(SO_4)_3]^{3-} + SO_4^{2-}$	$\frac{1}{q_{[Ce(SO_4)_3]^{3-}}} = \frac{3}{q_\infty} + \frac{1}{q_\infty \cdot K^{1/3}} \cdot \left( \frac{2[SO_4^{2-}]^{1/3} \cdot \gamma_{\pm MgSO_4}^{2/3}}{q_{[Ce(SO_4)_3]^{3-}}^{1/3} \cdot [Ce(SO_4)_2]^{2/3} \cdot \gamma_{\pm Mg(Ce(SO_4)_2)_2}} \right)$
$[Eu(H_2PO_4)]^{2+} + 2HR \leftrightarrow [Eu(H_2PO_4)]R_2 + 2H^+$	$\frac{1}{q_{Ln(H_2PO_4)R_2}} = \frac{1}{q_\infty} + \frac{1}{K^{1/2} \cdot q_\infty} \cdot \frac{a_{H^+} \cdot q_{Ln(H_2PO_4)R_2}^{-1/2}}{a_{Ln(H_2PO_4)R_2}^{1/2}}$

The linear forms of sorption isotherms and the obtained approximation dependences were used to calculate the values of the ion-exchange equilibrium constants, the Gibbs energy of ion exchange, and the values of the total capacity of the sorbent and extractant.

**Table 1.** Thermodynamic characteristics of sorption and solid-phase extraction

Ion	$q_\infty$ , mol/kg	$K$	$-\Delta G_{298}^0$ , kJ/mol
$[Ce(EDTA)]^-$	1,19±0,02	1,06±0,03	0,152±0,011
$[Ce(SO_4)_2]^-$	1,18±0,02	1,77±0,06	1,42±0,06
$[Eu(H_2PO_4)]^{2+}$	0,0195±0,0010	28,86±1,44	8,33±0,42

Thus, the applied thermodynamic model makes it possible to describe sorption and extraction equilibria, which makes it possible to predict the possibility of extracting rare-earth metals from complex-salt solutions.

#### References

- [1] Lutskiy D. S., Ignatovich A. S., Sulimova M. A. *J. Phys. Conf. Ser.* **2020.** 5,1399, 55-69.  
[2] Litvinova T.E. *FOG - Freiberg Online Geoscience.* **2015.** 40, 159-166.

Acknowledgements. This work was supported by the Russian Science Foundation (project No. 19-19-00377 "Technological basis for the extraction and selection of strategically important rare earth elements from apatite products") dated 22 April, 2019.

EFFECTS OF TECHNOLOGICAL PARAMETERS ON PHASE TRANSFORMATIONS  
BaCO<sub>3</sub> – CaCO<sub>3</sub> – ZrO<sub>2</sub> – TiO<sub>2</sub> SYSTEM

Zarechnev V.V., *Prach A.A.*

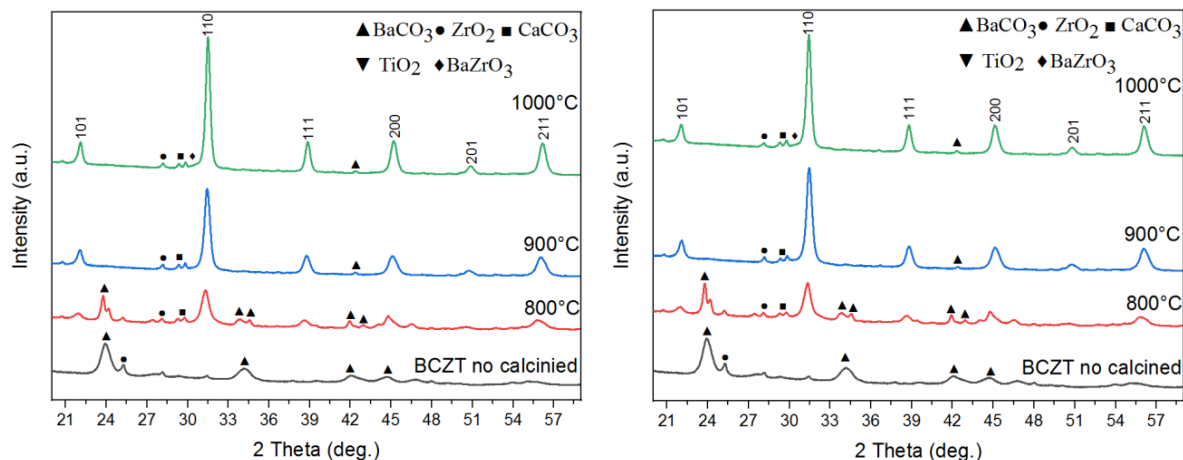
Tomsk Polytechnic University, Tomsk, Russia  
PhD student and student  
[heaven\\_for\\_everyone@inbox.ru](mailto:heaven_for_everyone@inbox.ru)

The most common piezoelectric materials are ferroelectric ceramics with a perovskite structure based on a solid solution of lead zirconate titanate (PZT). However, due to the content of a highly toxic component, lead, it does not meet modern environmental safety requirements. The toxicity of lead and its compounds is well understood. Exposure of lead on the body causes nervous disorders, diminished skeletal growth and disorders in the cardiovascular system [1]. Besides BaTiO<sub>3</sub> and BZT, Barium calcium zirconate titanate (BCZT) is a good candidate for a variety of applications, such as multilayer ceramic capacitors (MLCC), piezoelectric actuators due to its excellent dielectric, ferroelectric and piezoelectric properties [2].

Thus, the aim of this work is to investigate the influence of technological parameters, such as heating rate, annealing temperature, and dwell time on the formation of a single-phase composition (Ba<sub>0.85</sub>Ca<sub>0.15</sub>)(Ti<sub>0.9</sub>Zr<sub>0.1</sub>)O<sub>3</sub>.

The composition (Ba<sub>0.85</sub>Ca<sub>0.15</sub>)(Ti<sub>0.9</sub>Zr<sub>0.1</sub>)O<sub>3</sub> was synthesized via the conventional mixed-oxide method. The precursors were ball-milled in a planetary ball mill (Retsch PM 200) during 12 h, into a zirconia jars at 250 rpm. The powder was calcined at temperatures from 800-1000°C for 3 hours (heating rate 5 and 19°C/min) and heating rate 5°C/min with dwell time 4-6 hours. X-ray diffraction analysis of the powders were performed using XRD-7000S diffractometer (Shimadzu, Japan) in Bragg-Brentano geometry with CuKα (λ=1,5410 Å) radiation over the range of 2θ = 20–60° (steps of 0,0143°). The X-ray diffraction data were analyzed using Match!3 software with crystallography open database (COD).

Figure 1 shows the XRD pattern of the mixture of BaCO<sub>3</sub> – CaCO<sub>3</sub> – ZrO<sub>2</sub> – TiO<sub>2</sub> ball milled for 12 h, as milled and calcined at various temperatures (800, 900, 1000°C).



**Figure 1.** XRD patterns of the milled powder at room temperature and annealed at temperature from 800 to 1000°C for 3 h.

In the XRD pattern of the milled mixture without annealing is observed that the all diffraction peaks are attributed to the initial components. The XRD patterns of the powders annealed at 800°C show the evolution of crystallization process of BCZT. The peaks attributed to BaCO<sub>3</sub> (24°, 34°, 42°) disappeared after annealing at 900°C. Phase BCZT is formed with the increase of the annealing temperature up to 1000°C with the secondary phase corresponding to BaZrO<sub>3</sub> (30°).

#### References

- [1] Shamshad M., Soorambail K. *IOSR J. Environ. Sci. Toxicol. Food Technol.* **2015**, 9, 32–38
- [2] Sun S.L., Zheng Q.J. *J. Mater. Sci.: Mater. Electron.* **2015**, 26, 5270-5278

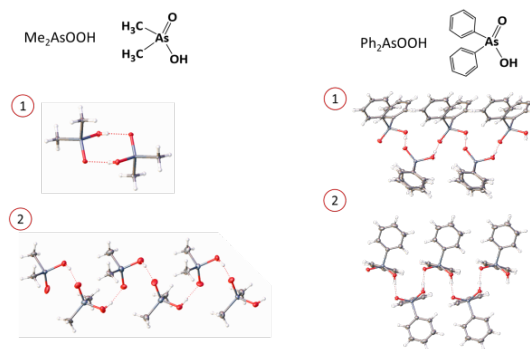
Acknowledgements. This work was supported by Development Strategy of Tomsk Polytechnic University.

# STRUCTURE OF HYDROGEN-BONDED COMPLEXES OF ARSINIC ACIDS IN CRYSTAL AND IN SOLUTION

*Puzyk A. M., Mulloyarova V.V., Tolstoy P.M.<sup>1</sup>*

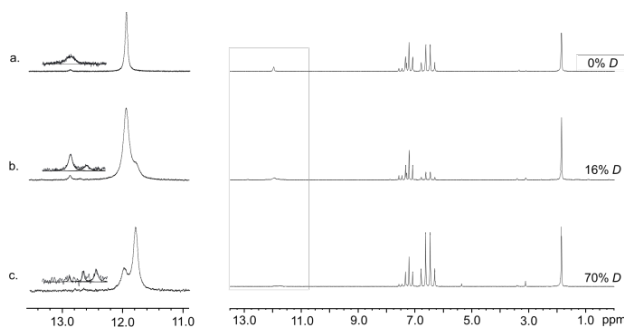
<sup>1</sup>Saint Petersburg State University, Saint Petersburg, Russia  
Student  
[sashapuzyk@yandex.ru](mailto:sashapuzyk@yandex.ru)

Molecules which have in their structure both proton-donor and proton-acceptor groups are capable to form hydrogen-bonded complexes of different stoichiometry and structure. All aware that carboxylic acids exist in the form of hydrogen-bonded cyclic dimers in solid, liquid and even in gaseous state [1-2]. Acids that contain phosphorus are less studied, but there is a number of scientific articles where are evidences of the formation of the hydrogen-bonded cyclic dimers, trimers and tetramers [3-4] in solution. The determination of the stoichiometry of the structure of the self-associates was carried out by <sup>1</sup>H and <sup>31</sup>P{<sup>1</sup>H} Nuclear Magnetic Resonance spectroscopy. Arsinic acids have been studied much less. A significant part of the scientific articles is devoted to the study of toxicology of organic and inorganic compounds, as well as the harmful effects on nature and humans. In CCDC there are crystal structures only of five acids. For a couple of them (dimethyl- and diphenylarsinic acids), was observed a tendency towards polymorphism (Fig. 1). Structures were determined by single crystal X-ray diffraction analysis for both acids which were recrystallized from different solvents.



**Figure 1.** The patterns of hydrogen bonds in two polymorphs of Me<sub>2</sub>AsOOH (on the left: 1. – Cyclic dimers; 2. – Infinite chains) and Ph<sub>2</sub>AsOOH (on the right: two types of Infinite chains)

The self-association of arsinic acids in solution have not been studied yet. By liquid-state <sup>1</sup>H NMR spectroscopy was made the elucidation of the stoichiometry of hydrogen-bonded self-associates and hetero-associates of cacodylic (Fig. 2) and diphenylarsinic acids in solution in aprotic polar media (deuterated liquified mix of freonic gases).



**Figure 2.** <sup>1</sup>H NMR spectra of solutions of DMA (0.009 M) in CDF<sub>3</sub>/CDF<sub>2</sub>Cl mixture at 100 K. a. – non-deuterated species. b., c. – species, partially deuterated in mobile proton site.

## References

- [1] Tolstoy P.M., Schah-Mohammedi P., *J. Am. Chem. Soc.*, **2004**, 126, 5621–5634;
- [2] Tsivintzelis I., Kontogeorgis G.M., *J. Phys. Chem.*, **2017**, 121, 2153–2163;
- [3] Mulloyarova V.V., Giba I. S., *Phys. Chem. Chem. Phys.*, **2018**, 20, 4901–4910;
- [4] Mulloyarova V.V., Ustimchuk D. O., *Molecules*, **2020**, 25, 1907.
- [5] Asfin R.E., Denisov G.S., *J. Mol. Struct.*, **2002**, 608, 161-168;

Acknowledgements. This work was supported by Russian Foundation for Basic Research (project No 20-03-00231).

SYNTHESIS AND LUMINESCENT PROPERTIES  
1-ARYL(GETARYL)-5-PHENYLPHENE-2,4-DIENE-1-ONATE OF BORON DIFLUORIDE

*Puzyrkov Z.N.*<sup>1,2</sup>, *Fedorenko E. V.*<sup>2</sup>, *Svistunova I. V.*<sup>1</sup>

<sup>1</sup>Far Eastern Federal University, Vladivostok, Russia

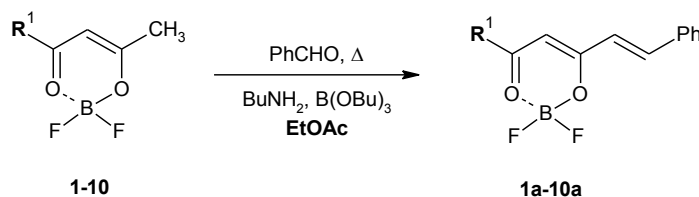
<sup>2</sup>Institute of Chemistry, Far Eastern Branch of the Russian Academy of Sciences, Vladivostok, Russia

PhD Student

[puzyrkov.zn@dvfu.ru](mailto:puzyrkov.zn@dvfu.ru)

Due to the rapid development of molecular electronics, non-linear optics and multiphotographic processes, the design of  $\beta$ -diketone-based dyes using boron difluoride is of paramount importance for these purposes [1,2]. The  $\beta$ -diketone-based polymethine and methine dyes of boron difluoride are known as intensively dyed and fluorescent substances, which have recently increased in interest due to their practical value, primarily as long-wavelength luminophores and objects for non-linear optics. Also, the boron complexes of curcumin structures refer to methine dyes. Curcumin is a natural polyphenol compound that demonstrates a wide spectrum of pharmacological activity [3]. Base-catalyzed double aldol condensation of aldehydes with acetylacetone is the standard method of assembly of the curcumin carcass [4]. So far, few dyes based on  $\beta$ -diketones have been described and there is no systematic research on the subject. On the other hand, the low resistance to hydrolysis and photodegradation of such dyes makes their extensive research and application difficult. Thus, the production of stable dyes based on  $\beta$ -diketones of boron difluoride and the systematic investigation of their physico-chemical properties is a relevant scientific and applied task.

In this work, we have obtained a series of 1-aryl(getaryl)-5-phenylphene-2,4-diene-1-onates of boron difluoride (**1a-10a**, figure 1) from aldol condensation of benzaldehyde with arylacetonates of boron difluoride (**1-10**). Conditions for the synthesis of methine dyes were selected: ethyl acetate was used as a solvent and butylamine as a catalysis [5]. The yield of the compounds obtained ranges from 11 to 75%.



R<sup>1</sup> = Ph- (**1a**); 4-CH<sub>3</sub>-C<sub>6</sub>H<sub>4</sub>- (**2a**); 4-Et-C<sub>6</sub>H<sub>4</sub>- (**3a**); 3,4-CH<sub>3</sub>-C<sub>6</sub>H<sub>3</sub>- (**4a**); 2,5-CH<sub>3</sub>-C<sub>6</sub>H<sub>3</sub>- (**5a**); 4-CH<sub>3</sub>O-C<sub>6</sub>H<sub>4</sub>- (**6a**);  
R<sup>1</sup> = beta-Naft (**7a**); Fluor (**8a**); Ph-Ph- (**9a**); Ph-CH=CH-Ph- (**10a**)

**Figure 1.** Synthesis scheme **1a-10a**

The luminescent properties of dilute solutions are investigated among the compounds **1a-10a**, which gives an idea of the electron structure of individual molecules in the main and excited states. For **6a-10a**, the absorption and luminescence spectra are shifted to the red region relative to **1a-5a** due to the long  $\pi$ -system. Among the compounds containing  $\pi$ -donor groups, the oscillating structure of the spectrum is less pronounced, and the spectra of luminescence and excitation of luminescence do not coincide, indicating a different structure of excited and underlying states. Compounds **2a**, **5a**, **6a** and **9a** show mechanochromic properties: when rubbing **2a** and **5a** change their luminescence color from yellow to green, **6a** and **9a** change their luminescence color from yellow to orange. For isomeric compounds that have only differences in the position of methyl substituents in the phenyl ring (**4a**, **5a**), the position of the maximum of the absorption spectrum differs by 20 nm, which is significant when the  $\pi$ -system of the molecule is the same.

### References

- [1] Mo H.-W., Tsuchiya Y., Geng Y., Sagawa T., Kikuchi C., H. Nakanotani, Ito F., Adachi C. *Adv. Funct. Mater.* **2016**, 26, 6703–6710
- [2] Zhang G., Lu J., Sabat M., Fraser C. L. *J. Am. Chem. Soc.* **2010**, 132, 2160–2162
- [3] Esatbeyoglu T., Huebbe P., Ernst I. M., Chin D., Wagner A.E., Rimbach G. *Angew Chem Int Ed Engl.* **2012**, 51, 5308–5332
- [4] Rao E.V., Sudheer P. *Indian J. Pharm. Sci.* **2011**, 73, 262–270
- [5] Liu K., Chen J., Chojnacki J., Zhang S. *Tetrahedron Lett.* **2013**, 54, 2070–2073

COMPLEX COBALT ANTIMONATES AS PROMISING CATALYSTS  
FOR CARBON MONOXIDE OXIDATION

*Razvorotneva L.S.<sup>1,2</sup>, Golodukhina S.V.<sup>2</sup>, Liberman E. Yu.<sup>3</sup>, Egorysheva A.V.<sup>2</sup>*

<sup>1</sup>National Research University Higher School of Economics, Russia

<sup>2</sup>Kurnakov Institute of general and inorganic chemistry RAS, Russia

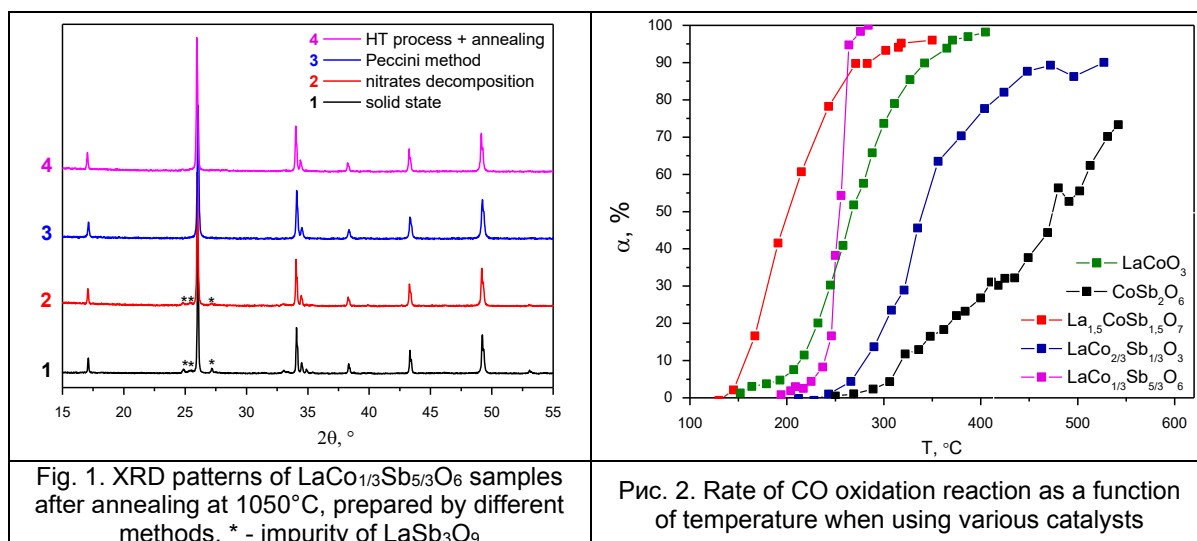
<sup>3</sup>Mendeleeev University of Chemical Technology of Russia

Student

[ladanichegoneznau@mail.ru](mailto:ladanichegoneznau@mail.ru)

Catalytic oxidation in the presence of oxygen is the most common method for removing carbon monoxide from exhaust fumes. We had earlier demonstrated high catalytic activity in this reaction of Ln and Fe complex antimonates. However, the catalytic properties of other transition metals are still unknown. Despite the great interest in cobalt oxides as catalysts for CO oxidation, the catalytic properties of cobalt antimonates have never been studied. The aim of our work was to study the catalytic activity of complex oxides in the  $\text{La}_2\text{O}_3 - \text{CoO} - \text{Sb}_2\text{O}_5$  system with different crystal structure. For this purpose it was necessary to develop a synthesis method suitable for all compounds in this system.

We considered various methods for the synthesis of complex antimonates using the example of  $\text{LaCo}_{1/3}\text{Sb}_{5/3}\text{O}_6$ . Due to high volatility of antimony oxides during high-temperature annealing, it is necessary to ensure a decrease in the synthesis temperature. Solid phase synthesis methods from oxides or synthesis by nitrate decomposition resulted in dirty samples (Fig. 1). Then we tried to use the Peccini method, which made it possible to obtain a single-phase sample, the catalytic activity of which, however, turned out to be low, probably due to the residues of organic precursors during the annealing of the sample. To reduce the synthesis temperature, we also tried out the method of hydroxides coprecipitation with subsequent annealing. However, since co-precipitation of La, Co, and Sb hydroxides is not possible in alkali or  $\text{NH}_3$  solutions, we proposed a new synthesis method. We successfully obtained single-phase samples by annealing the precipitate after hydrothermal treatment of a La and Co hydroxides suspension with the addition of  $\text{Sb}_2\text{O}_3$ .



In the ternary system  $\text{La}_2\text{O}_3 - \text{CoO} - \text{Sb}_2\text{O}_5$ , ternary oxides related to the structures of rosiate ( $\text{LaCo}_{1/3}\text{Sb}_{5/3}\text{O}_6$ ), pyrochlore ( $\text{La}_{1.5}\text{CoSb}_{1.5}\text{O}_7$ ), and perovskite ( $\text{LaCo}_{2/3}\text{Sb}_{1/3}\text{O}_3$ ) are known. We used our new synthesis method for the listed compositions made and obtained all samples in the form of pure substances under the same conditions. Catalytic tests of the synthesized complex oxides in the reaction of CO oxidation with oxygen showed that rosiate  $\text{LaCo}_{1/3}\text{Sb}_{5/3}\text{O}_6$  and pyrochlore  $\text{La}_{1.5}\text{CoSb}_{1.5}\text{O}_7$  had a significantly higher activity than the similar perovskite  $\text{LaCo}_{2/3}\text{Sb}_{1/3}\text{O}_3$ , since they had lower temperatures of 90% CO oxidation (Fig. 2). This result indicates a significant effect of the catalyst crystal structure on the catalytic activity. In addition, it we found that the activity of the samples  $\text{LaCo}_{1/3}\text{Sb}_{5/3}\text{O}_6$  and  $\text{La}_{1.5}\text{CoSb}_{1.5}\text{O}_7$  was higher than that of the intensively studied perovskite  $\text{LaCoO}_3$ .

Thus, we have shown that complex antimonates with rosiate and pyrochlore structures are promising catalysts for CO oxidation.

Acknowledgements. This research was performed using the equipment of the JRC PMR IGIC RAS.

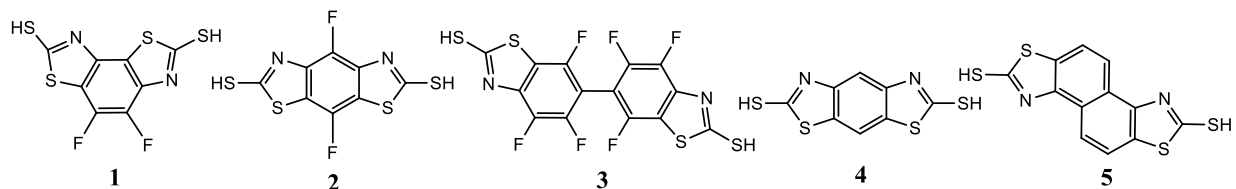
# NEW BISTHIAZOLEDITHIOLS AND THEIR SODIUM COMPLEXES. SYNTHESIS, STRUCTURE, LUMINESCENCE

*Rogozhin A.F.<sup>1</sup>, Ilichev V.A.<sup>1</sup>, Bochkarev M.N.<sup>1</sup>*

<sup>1</sup>G.A. Razuvaev Institute of Organometallic Chemistry of RAS, Nizhny Novgorod, Russia  
Student

[atonrog@iomc.ras.ru](mailto:atonrog@iomc.ras.ru)

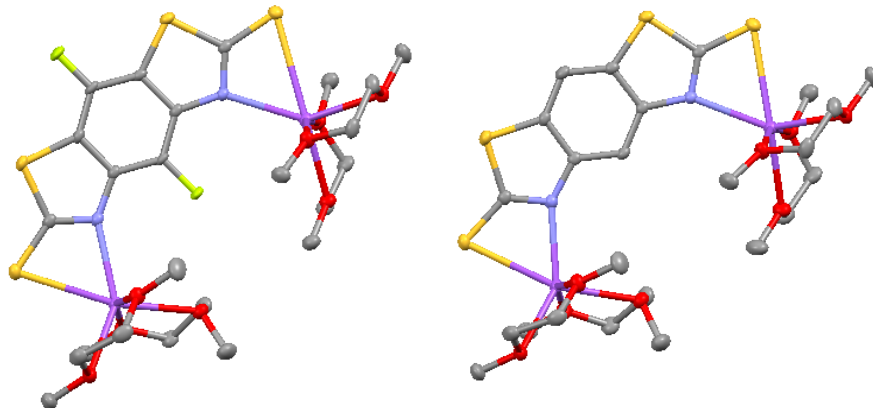
It's known that mercaptothiazolate ligands are effective sensitizers of lanthanide luminescence [1], which is demand in various modern technologies, like lasing, bioimaging and OLEDs. In order to expand the set of such ligands we have synthesized new mercaptobisthiazoledithiols **1-3**, **5** and previously known bisthiazole **4** (Fig. 1) by condensation reaction of halogen substituted nitro- and amino- aromatic derivatives with potassium ethylxantogenate or carbon disulphide and study their luminescent properties. New compounds were characterized by <sup>19</sup>F and <sup>1</sup>H NMR spectroscopy, mass-spectroscopy and CHNS elemental analysis.



**Figure 1.** Set of synthesized bisthiazoledithiols.

Disodium complexes bisthiazoles **1-5** were synthesized in order to determine the triplet level of the ligands from their low-temperature phosphorescence spectra. By the recrystallization from DME crystals suitable for XRD analysis were obtained. Molecular structures of sodium complexes of **1** and **4** are presented (Fig. 2). As expected, the bisthiazolates are coordinated on sodium ions bidentately via nitrogen and thiolate sulphur atoms.

Low-temperature PL spectra of the disodium complexes consist of a short-lived component (fluorescence) and a long-lived component (phosphorescence). For the bisthiazoles **1-4** the triplet level values range from 21200 cm<sup>-1</sup> to 21500 cm<sup>-1</sup> while for **5** the value of the triplet state is 18900 cm<sup>-1</sup>. The triplet levels of the bisthiazoles have rather high values relative to the position of the resonance *f* levels of many lanthanides, including Tb (20400 cm<sup>-1</sup>), Sm (17800 cm<sup>-1</sup>) and Eu (17500 cm<sup>-1</sup>). Consequently, synthesized bisthiazoles are capable of sensitizing the metal-centered PL of most lanthanides.



**Figure 2.** Molecular structures of sodium complexes of **1** (a) and **4**(b).

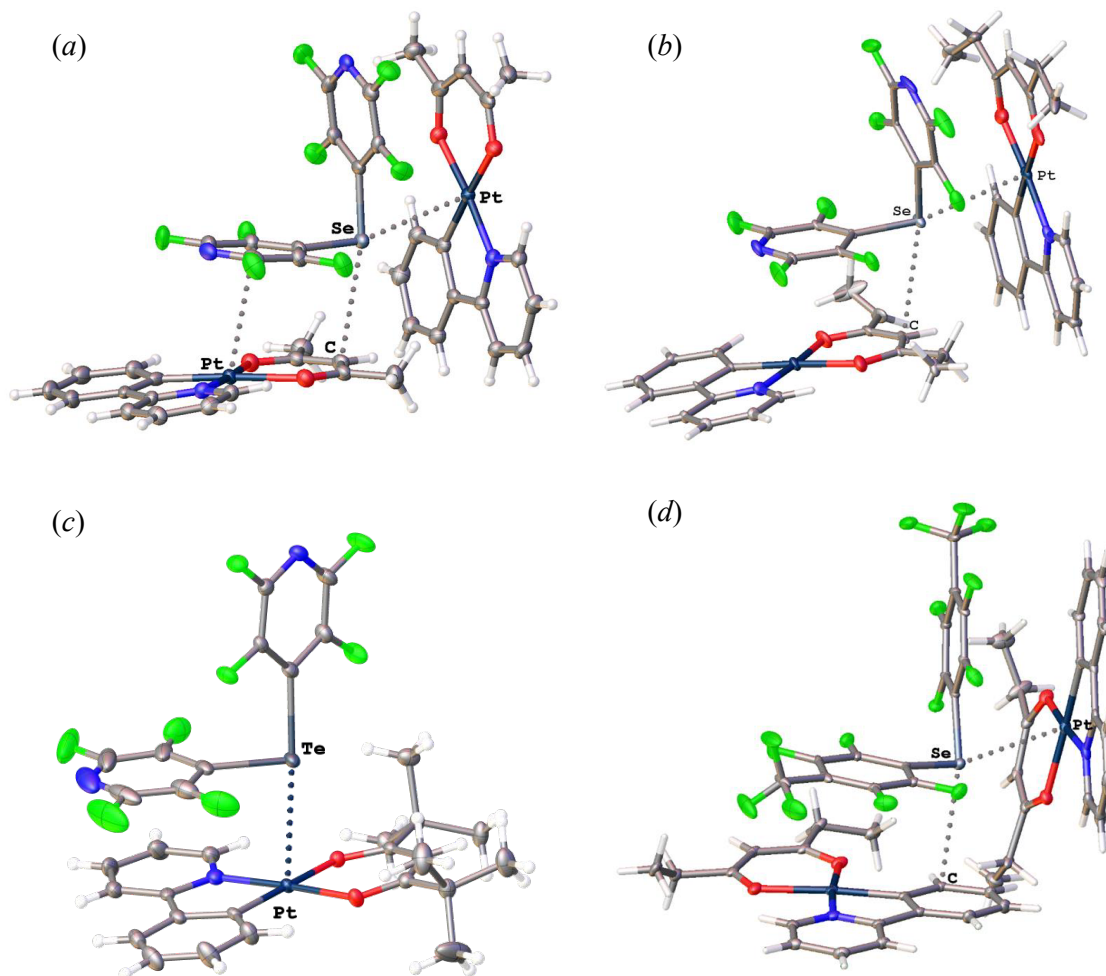
The presence of two thiolate groups in the bisthiazoles **1-5**, their luminescence and high triplet values make these ligands promising materials for a design of new lanthanide-containing polynuclear compounds, coordination polymers and MOFs exhibiting luminescence in visible and near infrared ranges.

## References

[1] Ilichev V.A., Silantyeva L.I., Yablonskiy A.N., Andreev B.A., Rummyantsev R.V., Fukin G.K., Bochkarev M.N. *Dalton Trans.* **2019**, *48*, 1060–1066

Acknowledgements. This work was supported by the Russian Science Foundation (project No 20-73-10115).

The platinum(II) complexes exhibiting a  $dz^2$ -nucleophilicity, viz. [Pt(ppy)(acac)] (**1**; acacH is acetylacetonate; ppyH is 2-Ph-pyridine), [Pt(ppy)(Etacac)] (**2**; EtacacH is heptane-3,5-dione) and [Pt(ppy)(tmhd)] (**3**; tmhdH is 2,2,6,6-tetramethylheptanedione-3,5), were co-crystallized with the chalcogen bond donors (4-NC<sub>5</sub>F<sub>4</sub>)<sub>2</sub>Ch, (4-CF<sub>3</sub>C<sub>6</sub>F<sub>4</sub>)<sub>2</sub>Se (Ch = Se, Te) to form co-crystals **1**·½(4-NC<sub>5</sub>F<sub>4</sub>)<sub>2</sub>Ch, **2**·½(4-NC<sub>5</sub>F<sub>4</sub>)<sub>2</sub>Ch, **2**·(4-CF<sub>3</sub>C<sub>6</sub>F<sub>4</sub>)<sub>2</sub>Se, **3**·¾(4-NC<sub>5</sub>F<sub>4</sub>)<sub>2</sub>Se and **3**·(4-NC<sub>5</sub>F<sub>4</sub>)<sub>2</sub>Te. The X-ray data for these co-crystals allowed the recognition of the metal-involving chalcogen bond, namely Ch··· $dz^2$ -Pt<sup>II</sup> (fig. 1).



**Figure 1.** Structures of co-crystals **1**·½(4-NC<sub>5</sub>F<sub>4</sub>)<sub>2</sub>Se (a), and **2**·½(4-NC<sub>5</sub>F<sub>4</sub>)<sub>2</sub>Se (b), **3**·(4-NC<sub>5</sub>F<sub>4</sub>)<sub>2</sub>Te and **2**·(4-CF<sub>3</sub>C<sub>6</sub>F<sub>4</sub>)<sub>2</sub>Se (d).

Acknowledgements. This work was supported by Russian Science Foundation (project No 21-73-10030).



## SONOCHEMICAL NANOSTRUCTURING OF CU-ZN ALLOY

*Sabbouh N.M.*<sup>1</sup>, *Shilovskikh V.V.*<sup>2</sup>

<sup>1</sup>Itmo national research university, Saint Petersburg, Russia

<sup>2</sup>Faculty of infochemistry, St. Petersburg, Russia

PhD Student

[sabbukh@infochemistry.ru](mailto:sabbukh@infochemistry.ru)

Ultrasonic irradiation of liquids causes high-energy chemical reactions to occur, often with the emission of light. [1-3] The origin of sonochemistry and sonoluminescence is acoustic cavitation: the formation, growth, and implosive collapse of bubbles in liquids irradiated with high-intensity sound. The collapse of bubbles caused by cavitation produces intense local heating and high pressures, with very short lifetimes. In clouds of cavitating bubbles, these hot-spots[4] have equivalent temperatures of roughly 5,000 K, pressures of about 1,000 atm, and heating and cooling rates above 10<sup>10</sup> K s<sup>-1</sup>. In single bubble cavitation, conditions may be even more extreme. Thus, cavitation can create extraordinary physical and chemical conditions in otherwise cold liquids.

In our work we used copper-zinc alloy (brass) in forms of powder and flat plates. Powders were used as furnished, plates were cut from a single sheet, grinded on a sandpapers and polished on progressively smaller diamond powders with the ending step of 0.5µm. Then samples were exposed to high energy ultrasonic treatment.

A series of samples was exposed to ultrasonic irradiation of different intensity, the samples were studied with several methods including optical and scanning electron microscopy. For two samples electron backscatter electron diffraction (EBSD) maps were constructed and microhardness by Vickers method was measured.

Electron backscatter diffraction data shows that initially brass consists of grains up to 100 µm<sup>2</sup> in area. Metal surface after intensive irradiation undergo shockwave deformations which do not decrease grain size, but greatly enhances internal misorientation degree which can result in significant increase in active sites' number and thus in catalytic activity of both copper and zinc. The effect of surface modification quickly decreases under the sample's surface and is neglectable at the distance of several micrometers. It was shown that brass alloy does not change its surface hardness which means that perspective catalyst may be used in almost every field where brass is mechanically applicable.

### References

[1] Crum, L. A.; Mason, T. J.; Reisse, J.; Suslick, K.S., Eds. Sonochemistry and Sonoluminescence, NATO ASI Series C, v. 524; Kluwer: Dordrecht, The Netherlands, **1999**.

[2] Mason, T. J.; Lorimer, J. P. Sonochemistry: Theory, Applications and Uses of Ultrasound in Chemistry **1988**, Ellis Horwood: Chichester, UK.

[3] Luche, J.-L. Synthetic Organic Sonochemistry **1998**, New York: Plenum.

[4] Suslick, K. S.; Cline, Jr., R. E.; Hammerton, D. A. J. Am. Chem. Soc. **1986**, 108, 5641–5642.

ELECTROCHEMICAL SYNTHESIS AND REACTIVITY OF ORGANONICKEL SIGMA-COMPLEXES IN C—C AND P—C BOND FORMATION

*Sakhapov I.F.*<sup>1</sup>, *Gafurov Z.N.*<sup>1</sup>, *Yakhvarov D.G.*<sup>1,2</sup>

<sup>1</sup> Arbuzov Institute of Organic and Physical Chemistry, FRC Kazan Scientific Center, RAN, Kazan, Russia

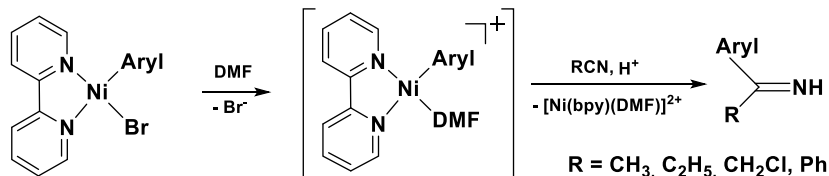
<sup>2</sup> Alexander Butlerov Institute of Chemistry, Kazan Federal University, Kazan, Russia

Young Scientist

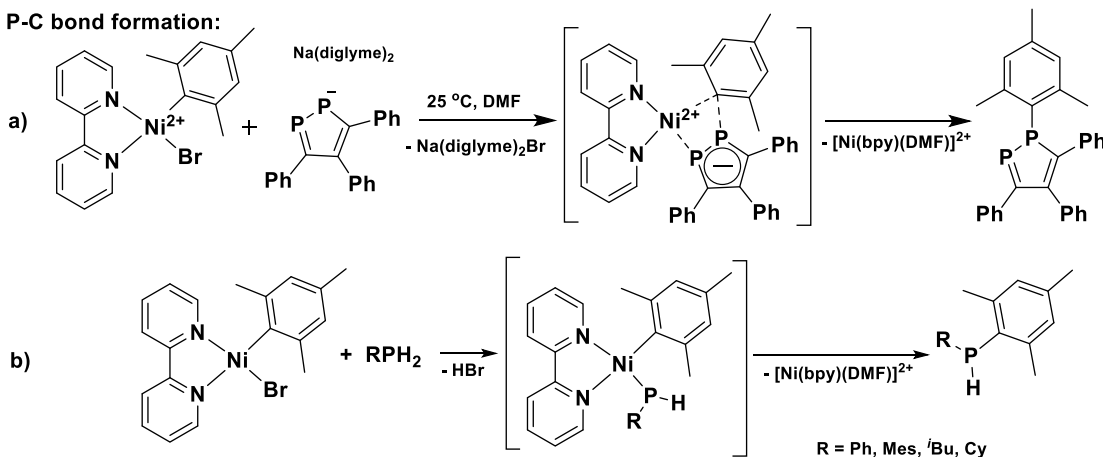
[sakhapovilyas@mail.ru](mailto:sakhapovilyas@mail.ru)

Organonickel  $\sigma$ -complexes are organometallic compounds containing Ni-C  $\sigma$ -bonding. These species are very reactive and have been characterized as intermediate products of catalytic cross-coupling and homo-coupling processes involving organic and organoelement substrates. [1]

1) C-C bond formation:



2) P-C bond formation:



**Figure 1.** 1. C-C bond formation; 2. P-C bond formation with the participation of organonickel sigma complexes and various organic substrates

The reactivity of sigma-complexes of the organonickel type  $[\text{NiBr}(\text{Aryl})(\text{bpy})]$ , where Aryl = 2,6-dimethylphenyl (Xyl), 2,4,6-trimethylphenyl (Mes), 2,4,6-triisopropylphenyl (Tipp), 2,4,6-tricyclohexylphenyl (Tchp), bpy = 2,2'-bipyridine, with respect to nitriles (acetonitrile, propionitrile, chloroacetonitrile, benzonitrile). This reaction leads to the formation of imines due to the formation of a new carbon-carbon bond between the aromatic fragment and the nitrile group  $\text{C}=\text{N}$ . [2]

The reactivity with respect to phosphine  $\text{PH}_3$  was also studied. The reaction leads to the primary mesityl phosphine ( $\text{MesPH}_2$ ) as the main product and dimesityl phosphine ( $\text{Mes}_2\text{PH}$ ) as the secondary product with the nickel complex as the transmetalizing agent. The resulting  $\text{MesPH}_2$  reacts with an excess of the complex to give  $\text{Mes}_2\text{PH}$  as the major product. [3]

Organonickel sigma-complexes are active catalysts for various catalytic processes and also make it possible to obtain compounds that cannot be obtained by the methods of classical chemistry. Secondary phosphines were obtained from sigma-complexes, which were subsequently used to obtain new phosphine-amino acids. [4]

**References**

- [1] Yakhvarov D.G. *Organometallics*. **2014**, 33, 18, 4574-4589  
 [2] Gafurov Z.N. *Russ. Chem. Bull.* **2017**, 66, 2, 254-259  
 [3] Gafurov Z.N. *Phosphorus Sulfur Silicon Relat Elem.* **2020**, 195, 9, 726-729  
 [4] Soficheva O. S. *Mendel. Comm.* **2020**, 30, 4, 516-518

Acknowledgements. This work was supported by the Russian Foundation for Basic Research (project No 19-29-08051)

# TECHNETIUM PENTACARBONYL HYDRIDE SYNTHESIS

Sakhonenkova A.P.<sup>1</sup>

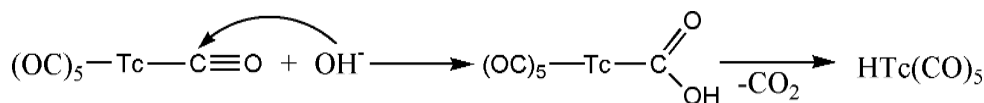
<sup>1</sup>Saint Petersburg State University, Saint Petersburg, Russia

Student

[annash000@gmail.com](mailto:annash000@gmail.com)

Techneium (I) pentacarbonyl hydride,  $\text{TcH}(\text{CO})_5$ , was obtained in 1962 by Hileman's group by a method similar to that used for obtaining  $\text{ReH}(\text{CO})_5$ . Pure  $\text{Tc}_2(\text{CO})_{10}$  was dissolved in THF and reacted with a sodium amalgam to give the anion  $[\text{}^{99}\text{Tc}(\text{CO})_5]^-$ , which was separated from the reaction mixture and treated with a weak acid at  $0^\circ\text{C}$  [1]. The structure of  $\text{TcH}(\text{CO})_5$  was described by infrared spectroscopy. The spectra are similar to those of  $\text{HRe}(\text{CO})_5$  and  $\text{HMn}(\text{CO})_5$  and consist of strong signals  $2021\text{ cm}^{-1}$ ,  $2015\text{ cm}^{-1}$  and a weak signal in the hydrogen deformation area  $685\text{ cm}^{-1}$  [2].

We found another way of  $\text{TcH}(\text{CO})_5$  formation by alkaline hydrolysis of  $[\text{Tc}(\text{CO})_6]^+$ . This does not require the presence of reducing agents. Therefore principle new mechanism of  $\text{TcH}(\text{CO})_5$  formation takes place (Fig.1). The carbonyl ligand, which forms the technetium hexacarbonyl cation, acts as a reducing agent. The structure of the reaction products was proved by IR spectroscopy in the gas phase and in hexane solution. The reaction path was confirmed by DFT analysis.



**Figure 1.** Mechanism of  $\text{TcH}(\text{CO})_5$  formation.

This method does not suite for preparation of reasonable amount of  $\text{TcH}(\text{CO})_5$  due to difficulties in obtaining technetium decacarbonyl. So we have found another way of technetium pentacarbonyl hydride synthesis from technetium pentacarbonyl halide treated by hydrogen generated during interaction of Zn dust and phosphoric acid. Formation of  $\text{TcH}(\text{CO})_5$  was proved by IR spectrometry.

We also studied thermal stability of technetium pentacarbonyl hydride. It turned out that heating to  $80^\circ\text{C}$  in air leads to formation of decacarbonyl technetium, while in inert atmosphere no changes were observed.

## References

- [1] Hileman J.C, Huggind D.K., Kaesz H.D. *Inorg. Chem.* **1962**, 933-939  
[2] Kaesz H.D., Huggind D.K *Can. J. Chem.* **1962**, 1250-1255

# SYNTHESIS OF NaFePO<sub>4</sub> AS ELECTRODE MATERIAL FOR SODIUM-ION BATTERIES THROUGH MILD ION-EXCHANGE APPROACH

*Samarin A.Sh.*<sup>1</sup>, *Nazarov E.E.*<sup>1</sup>, *Fedotov S.S.*<sup>1</sup>

<sup>1</sup>Skoltech Center for energy Science and Technology, Skoltech, Moscow, Russia

PhD Student

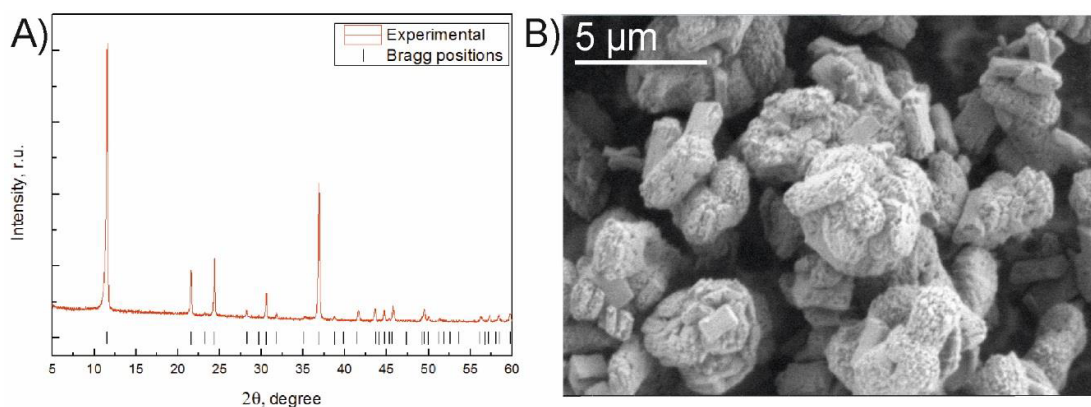
[aleksandr.samarin@skoltech.ru](mailto:aleksandr.samarin@skoltech.ru)

During last decades great attention was drawn to the various materials for metal-ion batteries [1]. A number of transition metal phosphates families were proposed as positive electrode materials for sodium-ion batteries, such as NASICONs, *natisite* (Na<sub>3</sub>V<sub>2</sub>(PO<sub>4</sub>)<sub>2</sub>(O,F)<sub>3</sub>), NaMPO<sub>4</sub>, etc. [2, 3].

NaMPO<sub>4</sub> possess two polymorphs – *maricite* and *triphylite*-type. Despite both modifications have generally similar close-packed oxygen lattice, the occupancy of M1 and M2 positions by Na<sup>+</sup> and M<sup>2+</sup> (M = Fe, Mn, e.g.) cations is different [4]. In the *triphylite*-type, Na<sup>+</sup> and M<sup>2+</sup> occupy preferentially M1 and M2 sites, while the opposite occupancy is observed in the second one – mobility of Na<sup>+</sup> ions is blocked and maricite-structured NaMPO<sub>4</sub> is almost electrochemically inactive. Additionally, for the NaMPO<sub>4</sub> composition the *maricite* polymorph is the most thermodynamically stable, which does not allow to synthesize *triphylite*-NaMPO<sub>4</sub> via conventional solid-state method. At the same time, *chimie douce* (mild chemistry) approaches can be feasible towards stabilization the desirable modification. Recently, several reports were published devoted to the synthesis of *triphylite*-structured NaMPO<sub>4</sub> using *dittmarite*-type, NH<sub>4</sub>MPO<sub>4</sub>·H<sub>2</sub>O, as precursors [5].

The aim of this work is the synthesis and investigation of electrochemical properties of *triphylite*-NaFePO<sub>4</sub>.

Samples of NaFePO<sub>4</sub> were synthesized through a two-step method. At the first step, a *dittmarite*-structured NH<sub>4</sub>FePO<sub>4</sub>·H<sub>2</sub>O was obtained by co-precipitation or microwave-assisted hydrothermal treatment. Samples obtained in a microwave hydrothermal reactor using FeSO<sub>4</sub>·7H<sub>2</sub>O, (NH<sub>4</sub>)<sub>2</sub>HPO<sub>4</sub> and ascorbic acid (τ = 10 min, 120 °C) as initial reagents consist of primary particles, which form agglomerates close to spherical ones (figure 1, B). The phase purity was confirmed using XRD (S.G. *Pmn*2<sub>1</sub>, *a* = 5.656(1) Å, *b* = 8.861(2) Å, *c* = 4.815(1) Å, *V* = 241.3(1) Å<sup>3</sup>) and obtained data are in good agreement with the given in literature (figure 1, A) [5]. The following ion-exchange was performed in mixture of NH<sub>4</sub>FePO<sub>4</sub>·H<sub>2</sub>O and excess of Na glutamate in muffle furnace at 190 °C for 10 h, resulting in a phase pure *triphylite*-NaFePO<sub>4</sub> (S.G. *Pnm*, *a* = 10.411(2) Å, *b* = 6.221(1) Å, *c* = 4.947(1) Å, *V* = 320.4(1) Å<sup>3</sup>). The crystal structure of both compounds was additionally proved by IR spectroscopy. Special attention during presentation will be devoted to the electrochemical properties of *triphylite*-NaFePO<sub>4</sub>.



**Figure 1.** A) XRD pattern ( $\lambda = 1.7889$ ) and Bragg reflexes position of the NH<sub>4</sub>FePO<sub>4</sub>·H<sub>2</sub>O. B) SEM images of NH<sub>4</sub>FePO<sub>4</sub>·H<sub>2</sub>O.

## References

- [1] Abakumov A.M., Fedotov S.S., *Nat. comm.*, **2020**, 11, 1-14
- [2] Zakharkin M.V., Drozhzhin, O.A., *ACS Appl. Energy Mater.* **2018**, 1, 5842-5846
- [3] Fedotov S.S., Samarin A.Sh., *J. Pow. Sources.* **2020**, 480, 228840
- [4] Berlanga C., Monterrubio I., *ACS Sustainable Chem. Eng.*, **2020**, 8, 725-730
- [5] Koleva V. G., Boyadzhieva T. J., *J. Cryst. Growth*, **2019**, 3744-3754

Acknowledgements. This work was supported by the Russian Foundation for Basic Research (project № 18-29-12097).

# SYNTHESIS OF NITROPHENOXY-SUBSTITUTED MAGNESIUM AND ZINC PHTHALOCYANINES COMPLEXES AND INVESTIGATION OF THEIR SPECTRAL-LUMINESCENT PROPERTIES

*Sarvin I.A., Erzunov D.A., Vashurin A.S.*

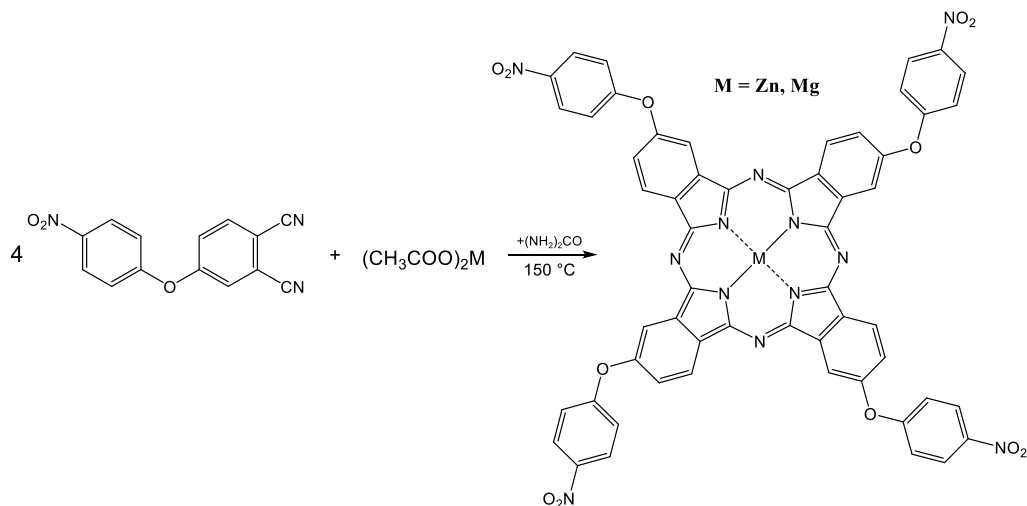
Ivanovo State University of Chemistry and Technology

Student

[sarvin2002@mail.ru](mailto:sarvin2002@mail.ru)

Phthalocyanines are a class of macrocyclic synthetic compounds, relatives of porphyrins, their 18- $\pi$  electron structure determines their special physical and chemical properties. Intensive absorption in the visible area, gives them wide usage as dyes and pigments. Aggregation is an important factor in studying the properties of phthalocyanines, as complexes have a high tendency to form aggregated molecules.

This work describes the synthesis method (Scheme 1) and the study of the electronic absorption spectra of metal complexes of nitrophenoxy-substituted phthalocyanines.



**Scheme 1.** Synthesis of tetra-4-(4-nitrophenoxy) phthalocyaninates of zinc and magnesium

The synthesis was carried out by the method of template fusion of phthalonitrile with metal acetates in a molar ratio of 4: 1, in the presence of carbamide. Fusion took place at  $150^\circ\text{C}$  and lasted for 20 minutes. The reaction mixture then was purified by Soxhlet extraction with chloroform. The structure of the compounds was confirmed by using  $^1\text{H}$  NMR and IR spectroscopy, MALDI-TOF mass spectrometry and electron spectroscopy.

Electronic absorption spectra were recorded in dimethyl sulfoxide and acetone. Fluorescence quantum yields and fluorescence lifetime were measured in tetrahydrofuran and acetone.

**Acknowledgements.** The work was supported by the Russian Science Foundation, grant № 17-73-20017.

STRUCTURAL FEATURES OF COMPLEXES OF LEWIS ACIDS  $E(C_6F_5)_3$  ( $E = B, Al, Ga, In$ )  
WITH 2-AMINOPYRIDINE

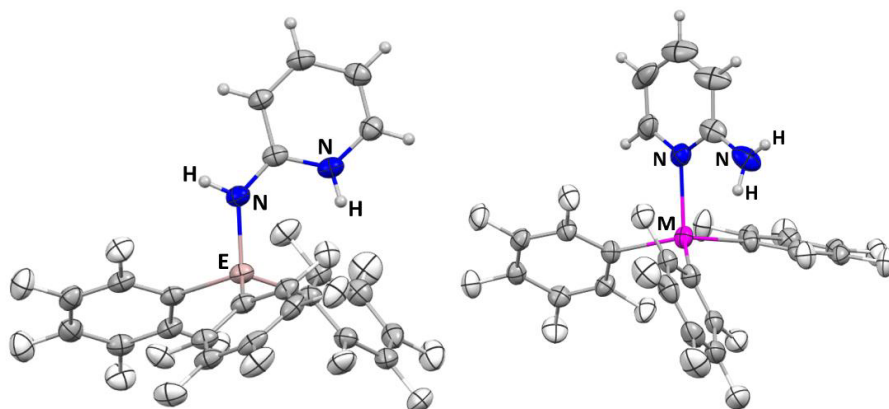
*Shcherbina N.A., Kazakov I.V., Timoshkin A.Y.*

Saint Petersburg State University, Saint Petersburg, Russia

Student

[st055673@student.spbu.ru](mailto:st055673@student.spbu.ru)

Lewis acids are involved in many catalytic reactions: polymerization, isomerization and cracking of alkanes, alkylation of aromatic hydrocarbons [1]. The Lewis acid  $B(C_6F_5)_3$  is used as an initiator of cationic polymerization of vinyl ether in aqueous media [2] and a co-catalyst in the Ziegler–Natta reaction [3]. The combination of spatial loading with strong electron acceptor activity allows  $B(C_6F_5)_3$  to be component of Frustrated Lewis Pairs (FLP) [4]. The compounds  $E(C_6F_5)_3$  ( $E = Al, Ga, In$ ) are stronger Lewis acids than  $B(C_6F_5)_3$  [5]. The reactions with 2-aminopyridine is interesting due to existing of two nitrogen atoms with different nature: N atom of the pyridine ring and amino group. In the present research the structures of the complexes  $E(C_6F_5)_3$  ( $E = B, Al, Ga, In$ ) with 2-aminopyridine were established by X-ray structural analysis for the first time (Fig. 1). Data obtained revealed the existence of two different structures depending on the nature of the central atom. For  $E(C_6F_5)_3$  ( $E = B, Al$ ) zwitterionic compound was observed. Boron and aluminum atoms bind the 2-amino-substituent with simultaneous transfer of a proton to the N atom of the pyridine ring. It is interesting to note that although the N atom of the pyridine ring is more basic than the amino-substituent, Lewis acids prefer coordination to the amino group. In zwitterionic structures bond lengths B–N 1.563(2) Å and Al–N 1.885(1) Å are significantly shorter than donor-acceptor bonds in complexes of  $E(C_6F_5)_3$  ( $E = B, Al$ ) with pyridine: B–N 1.625(5) Å and Al–N 1.959(2) Å [6]. Note that the previously described the shortest bond length for donor-acceptor complexes with  $Al(C_6F_5)_3$  is 1.945(2) [7]. For  $M(C_6F_5)_3$  ( $M = Ga, In$ ) classic donor-acceptor complexes with bonding via N atom of the pyridine ring were observed. The bond lengths Ga–N 2.018(2) Å and In–N 2.217(3) Å are very close to bond lengths in complexes  $M(C_6F_5)_3$  ( $M = Ga, In$ ) with pyridine: Ga–N 2.032(2) Å and In–N 2.243(2) Å [6]. Thus, the process of proton transfer and subsequent coordination of  $Al(C_6F_5)_3$  to the amino group makes it possible to achieve compound with super short Al–N bond length.



**Figure 1.** Molecular structures of complexes in crystals. The left one is  $E(C_6F_5)_3 \cdot C_5H_6N_2$  ( $E = B, Al$ ). The right one is  $M(C_6F_5)_3 \cdot C_5H_6N_2$  ( $M = Ga, In$ ).

#### References

- [1] Geier S.J., Chase P.A., Stephan D.W., *Chem. Commun.* **2010**, 46, 4884 – 4886.
- [2] Zhang J., Wu Y., Chen K., Zhang M., Gong L., Yang D., Li S., Guo W. *Polymers* **2019**, 11, 500.
- [3] Nomura K., Nagai G., Izawa I., Mitsudome T., Tamm M., Yamazoe S. *ACS Omega* **2019**, 20, 18833–18845.
- [4] Liu L.L., Cao L.L., Shao Y., Stephan D.W. *J. Am. Chem. Soc.* **2017**, 139, 10062–10071.
- [5] Timoshkin A.Y., Frenking G., *Organometallics* **2008**, 27, 371–380.
- [6] Shcherbina N.A., Kazakov I.V., Pomogaeva A.V., Lisovenko A.S., Kryukova M.A., Doinikov D.A., Gugin N.Y., Kondrat'ev Y.V., Timoshkin A.Y., *J. Organomet. Chem.* **2021**, in press.
- [7] Mountford A.J., Clegg W., Coles S.J., Harrington R.W., Horton P.N., Humphrey S.M., Hursthouse M.B., Wright J.A., Lancaster S.J. *Chem. Eur. J.* **2007**, 13, 4535 – 4547.

Acknowledgements. This work was supported by the Russian Science Foundation (project No 18-13-00196). Use of equipment of Resource centers “Magnetic resonance research centre”, “Centre for X-ray diffraction studies” and “Chemical analysis and materials research centre” of the Scientific park of St. Petersburg State University is gratefully acknowledged.

## SYNTHESIS AND MAGNETIC PROPERTIES OF Ni-Zn-Co FERROSPINELS

*Sherstyuk D.P.<sup>1</sup>, Starikov A.Yu.<sup>1</sup>, Zhivulin V.E.<sup>1</sup>, Zherebtsov D.A.<sup>1</sup>, Gudkova S.A.<sup>1</sup>, Perov N.S.<sup>2,3</sup>, Alekhina Yu.A.<sup>2</sup>, Astapovich K.A.<sup>4</sup>, Vinnik D.A.<sup>1</sup>, Trukhanov A.V.<sup>4</sup>*

<sup>1</sup>South Ural State University (National Research University), Chelyabinsk, Russia

<sup>2</sup>Lomonosov Moscow State University, Moscow, Russia

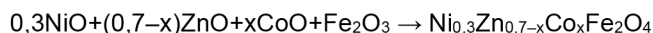
<sup>3</sup>Baltic Federal University, Kaliningrad, Russia

<sup>4</sup>SSPA “Scientific and Practical Materials Research Centre of NAS of Belarus”, Minsk, Belarus

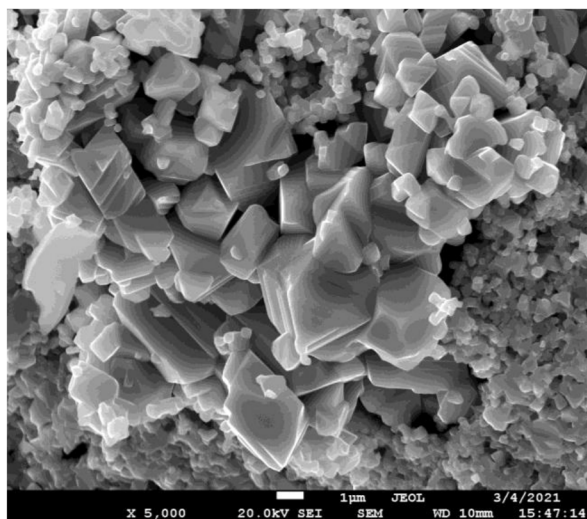
Student

[sherstuiukd@susu.ru](mailto:sherstuiukd@susu.ru)

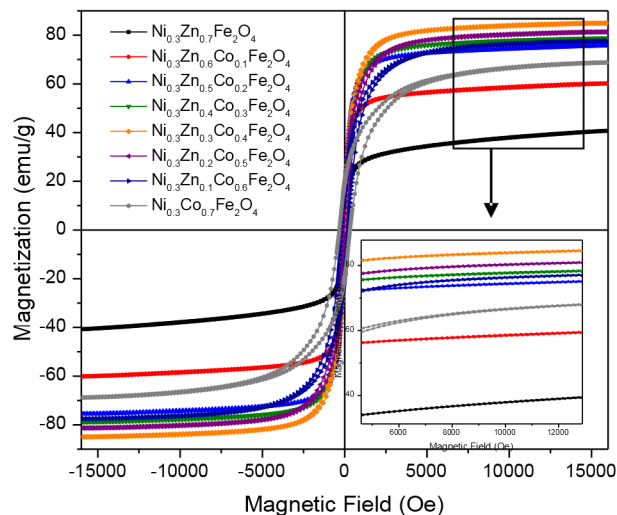
The creation of new materials that, due to their properties, will satisfy specific tasks is a fundamental task of modern materials science. An analysis of modern scientific literature has shown that an actual functional magnetic material for use in electronics is a class of ferrites with a spinel structure  $Ni_xZn_yCo_{(1-x-y)}Fe_2O_4$  ( $x=0-1$ ) [1]. This paper presents data on the synthesis and magnetic properties of a series of samples with the general formula  $Ni_{0.3}Zn_{0.7-x}Co_xFe_2O_4$  ( $x = 0-0.7$ ). The samples were obtained by solid-phase synthesis. The essence of the method consists in mechanical mixing of the oxides of the initial components in a stoichiometric ratio until a homogeneous powder is formed, after which the samples were compacted on a hydraulic press. At the final stage of the synthesis, the compressed tablets were sintered in a tubular high-temperature furnace (silicon carbide heater).



To study the kinetics of phase formation of the system, three preparatory syntheses of the same samples with sintering temperatures: 1100, 1150, and 1200 °C was carried out. To determine the phase composition, studies were carried out on a Rigaku Ultima IV powder diffractometer. As a result, a temperature of 1150 °C was chosen, since at this temperature the samples have the most improved crystal structure and pure phase composition (all samples are monophasic at this synthesis temperature). The study of the microstructure and quantitative analysis of the samples was carried out on a JEOL JSM 7001F scanning electron microscope). When studying the chemical composition, data were obtained that confirm the stoichiometry of the samples. The measurements of magnetic properties were carried out using a vibrating sample magnetometer Lakeshore 7400 series in the magnetic field range of  $\pm 16$  kOe at room temperature (see fig. 2). As a result, the following conclusions were obtained: established the optimal physicochemical synthesis conditions for the formation of monophasic samples of spinel ferrites; the saturation magnetization increases to 81.1 emu/g and then decreases, the maximum is observed in the sample  $Ni_{0.3}Zn_{0.3}Co_{0.4}Fe_2O_4$ . Remanent magnetization and coercivity increases with the cobalt concentration.



**Figure 1.** SEM image of the sample  $Ni_{0.3}Zn_{0.5}Co_{0.2}Fe_2O_4$



**Figure 2.** Hysteresis loops of the  $Ni_{0.3}Zn_{0.7-x}Co_xFe_2O_4$  system

### References

[1] Abu-Elsaad N.I., Nawara A.S., Mazen S.A. *J Phys Chem Solids*. **2020**, *146*, 109620

Acknowledgements. This work was supported by the RFBR (project No 20-38-70057) and President's grants for young doctors of science (MD-5612.2021.4).

# SYNTHESIS OF MAGNESIUM PHOSPHATES WITH Mg/P=1 RATIO FROM AMMONIUM HYDROPHOSPHATE AND VARIOUS MAGNESIUM SALTS

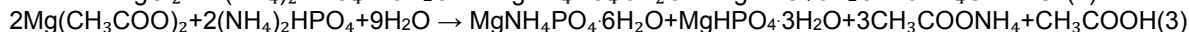
*Shevtsova O.A., Safronova T.V., Kazakova G.K.<sup>1</sup>*

<sup>1</sup>Moscow State University, Moscow, Russia  
Student

[shevtsovaolga7@yandex.ru](mailto:shevtsovaolga7@yandex.ru)

The aim of this work was to synthesize and study the properties of magnesium phosphate powders derived by interaction of aqueous solutions of various magnesium salts and dibasicammonium phosphate to produce resorbable ceramic materials.

The synthesis was carried out by precipitation from aqueous solutions of dibasicammonium phosphate and magnesium salts (nitrates, acetates and chlorides) to produce highly dispersive powders with a narrow particle distribution. In the first series of synthesis, the solution of dibasicammonium phosphate was added to the solution of chloride, nitrate and magnesium acetate. In the second series of synthesis, solutions of chloride, nitrate and magnesium acetate were added to the dibasicammonium phosphate solution. The quantity of reagents (dibasicammonium phosphate and soluble magnesium salts) were calculated using the reaction equations (1, 2 and 3):



The adding of one salt solution of the chosen pair of precursors was carried out using a drip funnel for an hour and at room temperature, using a magnetic stirrer to agitating the accepting solution of another salt and resultant suspension. The resulting suspensions of particles of magnesium insoluble salt in mother liquor then were left for 24 hours under stirring. The precipitate were then separated by decantation and filtered at reduced pressure on a paper filter of Buchner funnel. The filtered precipitate was dried in the air at room temperature until it completely dried out. Then powder was disaggregated using planetary mill and acetone as a liquid medium. After disaggregation and evaporation of acetone at room temperature, the powders were passed through the sieve. Later on, the obtained powder (a mixture of struvite  $\text{MgNH}_4\text{PO}_4 \cdot 6\text{H}_2\text{O}$  and newberite  $\text{MgHPO}_4 \cdot 3\text{H}_2\text{O}$ ) was investigated using various research methods (XRD, SEM, thermal analysis, granulometry). In the next step, the prepared powder mixture was pressed into tablets at a specific pressure of 50 MPa. Compacted powder preceramic samples were then fired in a range of temperatures from 800 °C to 1200 °C with a step of 100 °C. The following substances were examined with XRD and SEM. According to the XRD the phase composition of ceramic samples prepared based on powders of all 6 syntheses after heat treatment at different temperatures was presented by magnesium pyrophosphate ( $\text{Mg}_2\text{P}_2\text{O}_7$ ).

So a mixture of struvite  $\text{MgNH}_4\text{PO}_4 \cdot 6\text{H}_2\text{O}$  and newberite  $\text{MgHPO}_4 \cdot 3\text{H}_2\text{O}$  with different phase ratios was obtained from aqueous solutions of magnesium salts and dibasicammonium phosphate. It has also been found that the properties of synthesized powders was dependent on the receiving salt solution, i.e. sequence of solution adding. The ratio of the of struvite to newberite phases in case of addition of  $\text{MgCl}_2$  to  $(\text{NH}_4)_2\text{HPO}_4$  was 1:3; at the return sequence of solution addition ( $(\text{NH}_4)_2\text{HPO}_4$  to  $\text{MgCl}_2$ ), the ratio of struvite to newberite was 1:1. The ratio of the of struvite to newberite phases in case of addition of  $\text{Mg}(\text{CH}_3\text{COO})_2$  to  $(\text{NH}_4)_2\text{HPO}_4$  was 5:1; at the return sequence of solution addition (of  $(\text{NH}_4)_2\text{HPO}_4$  to  $\text{Mg}(\text{CH}_3\text{COO})_2$ ) the ratio of struvite to newberite was 8:3. When  $\text{Mg}(\text{NO}_3)_2$  and  $(\text{NH}_4)_2\text{HPO}_4$  are merged, the same ratio of struvite to newberite was observed as 1:2.

It has been established that a powdered mixture of struvite and newberite during firing at temperature in the range 800 °C to 1200 °C formed a porous ceramic material based on the high temperature modification of magnesium pyrophosphate  $\text{Mg}_2\text{P}_2\text{O}_7$ .

Ceramic porous materials containing a biocompatible and bioresorbable phase of high temperature modification of magnesium pyrophosphate  $\text{Mg}_2\text{P}_2\text{O}_7$  can be used for creating bone implants and also as a filler in composite materials with a polymer or inorganic matrix.

Acknowledgements. This work was supported by the Russian Foundation for Basic Research (project No 19-38-90274).



# LUMINESCENT PLATINUM (II) COMPLEXES BASED ON 2,2'-BIPYRIDINES

*Shilov R.A.<sup>1</sup>, Shakirova J.R.<sup>1</sup>*

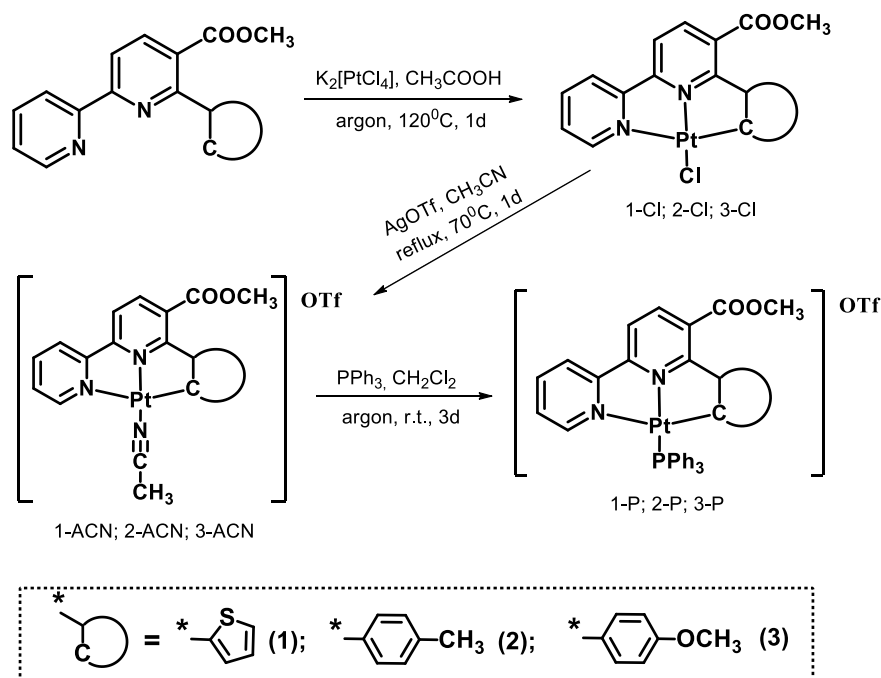
<sup>1</sup>Saint Petersburg State University, Saint Petersburg, Russia

Student

[st075625@student.spbu.ru](mailto:st075625@student.spbu.ru)

Today, many researchers devote their works to the study of luminescent complexes of platinum group elements with polydentate ligands. These adducts often turn out to be useful in plenty of different areas such as OLED technologies [1], bioimaging [2] and anticancer drugs [3]. Among them, platinum (II) complexes with N<sup>N</sup>^C-type pincer ligands are ones of the most well-investigated since they often reveal long lifetime of the excited state and high emission efficiency. What is also interesting about the complexes of this type is that their photophysical properties can be tuned by using different substituents in pincer ligands, which makes it possible to create probes with certain parameters, for example, NIR phosphorescent Pt(II) complexes with low cytotoxicity for bioimaging [2].

In current work we synthesized novel platinum (II) complexes with N<sup>N</sup>^C ligands according to the scheme represented in Figure 1.



**Figure 1.** Synthesis of platinum complexes

The complexes obtained were fully characterized by means of NMR spectroscopy, mass spectrometry and X-ray diffraction analysis. The photophysical properties of the complexes were thoroughly investigated. The influence of metalating fragment nature (thienyl, tolyl or p-methoxy-phenyl) and ancillary ligand (chloride, acetonitrile or phosphine) on photophysical parameters was also studied.

## References

- [1] Cebrián C., Mauro M. *Beilstein J. Org. Chem.* **2018**, *14*, 1459–1481
- [2] Esipova T.V., Barrett M.J., Erlebach E., Masunov A.E., Weber B., Vinogradov S.A. *Cell Metab.* **2019**, *29*, 736–744
- [3] Deo K.M., Ang D.L., McGhie B., Rajamanickam A., Dhiman A., Khoury A., Holland J., Bjelosevic A., Pages B., Gordon C., Janice R. *Coord. Chem. Rev.* **2018**, *375*, 148-163

**Acknowledgements.** The authors greatly appreciate financial support of RSF grant 19-73-20055. The work was carried out using equipment of the Research park of St. Petersburg State University (Centres for Magnetic Resonance, for Optical and Laser Materials Research, for Chemical Analysis and Materials Research, for X-ray Diffraction Studies, and Computing Center).

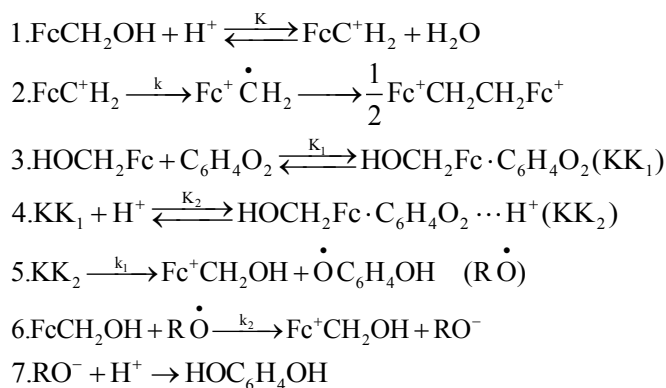
THE INFLUENCE OF PROTONATION IN THE OXIDATION PROCESS  
OF FERROCENYLMETHANOL WITH *p*-QUINONE IN THE PRESENCE OF PERCHLORIC ACID

*Shuklina N.N., Fomin V.M., Markin A.V.*

N. I. Lobachevsky State University of Nizhny Novgorod, Nizhny Novgorod, Russia  
Graduate student  
[niih325@bk.ru](mailto:niih325@bk.ru)

It is known that the oxidation of ferrocene derivatives with various functional groups with oxygen and hydroperoxides in the presence of strong acids (HX in the scheme) complicates the process of protonation of metal complexes, leading to the formation of ferrocenylcarbenium ions [1]. This communication presents the results of a kinetic study of the effect of the protonation of ferrocenylmethanol FcCH<sub>2</sub>OH with perchloric acid HClO<sub>4</sub> on its oxidation with *p*-quinone, which can manifest its properties only in the presence of acids.

It was shown that in the reaction system FcCH<sub>2</sub>OH + HX + *p*-quinone, leads to the oxidation of metal complexes not only with *p*-quinone, but also with a hydrogen ion as a result of its protonation. The need for strong acids to participate in both processes determines the influence of each of them on the rate of the other. This is confirmed by the characteristics of ferrocenium cations during protonation and the use of FcCH<sub>2</sub>OH with *p*-quinone from the action of reagents and by the kinetic equations describing these processes. The degree of their influence on each other depends on the solvating properties of the solvents and the ratio of the initial concentrations of metal complexes and acid, which affect the yield of the carbocation FcC<sup>+</sup>H<sub>2</sub> upon protonation of metal complexes and its ability to redox isomerism. Below is a generalized diagram of the process under study and expressions for its total rate in dioxane:



The kinetic analysis of the scheme leads to the following expression for the summary rate of the FcCH<sub>2</sub>OH oxidation ( $W_{\text{Fc}^+}$ ) which includes: the protonation rate ( $W_{\text{Fc}^+.1}$ ) and the rate of the oxidation with *p*-quinone ( $W_{\text{Fc}^+.2}$ ):

$$W_{\text{Fc}^+} = W_{\text{Fc}^+.1} + W_{\text{Fc}^+.2} =$$

$$= \frac{k K [\text{FcCH}_2\text{OH}]_0 [\text{H}^+]}{[\text{H}_2\text{O}] \left(1 + \frac{K [\text{H}^+]}{[\text{H}_2\text{O}]} + K_1 [\text{PQ}] + K_1 K_2 [\text{PQ}] [\text{H}^+]\right)} + \frac{2k_1 K_1 K_2 [\text{FcCH}_2\text{OH}]_0 [\text{PQ}] [\text{H}^+]}{1 + \frac{K [\text{H}^+]}{[\text{H}_2\text{O}]} + K_1 [\text{PQ}] + K_1 K_2 [\text{PQ}] [\text{H}^+]}$$

The transformation of the obtained equation with varying concentrations of reagents indicates the possibility of various modes of the process, which are confirmed by experimental studies.

#### References

[1] Fomin V., Shirokov A., Kochetkova K. Oxidation of derivants of ferrocene by molecular oxygen and peroxides. LAP LAMBERT Academic Publishing RU 2017. 361 p.

CALOMETRIC CHARACTERISATION OF THE  $[\text{WO}_2(\text{mnt})_2]^{2-}$  OXOTRANSFER PROCESS  
AS THE SYNTHETIC ANALOGUE OF THE REDUCTASES

*Simonova V.M., Khripun V.D.*

Saint Petersburg State University, Saint Petersburg, Russia

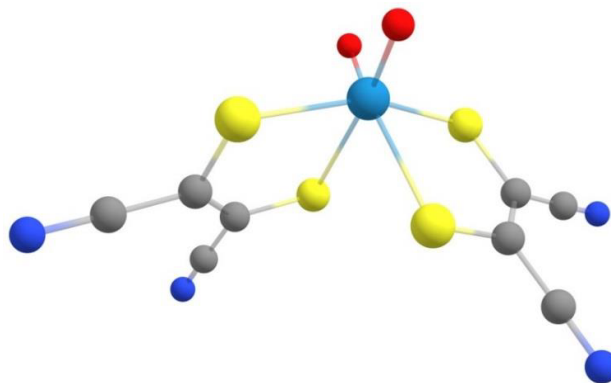
Student

[visucha\\_sk@mail.ru](mailto:visucha_sk@mail.ru)

Tungsten-containing enzymes play key role in the oxotransfer processes of the anaerobic organisms. Currently many of the analogues of tungsten-containing oxidoreductase active centers are synthesized. In spite of the huge amount of kinetic behavior of such systems in the solution [1] thermodynamic data is absent for the oxotransfer processes.

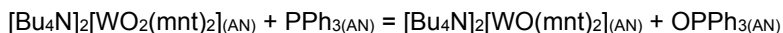
In the present work analogue of tungsten-containing oxidoreductase active center  $[\text{Bu}_4\text{N}]_2[\text{WO}_2(\text{mnt})_2]$  ( $\text{Bu}=\text{C}_4\text{H}_9$ ,  $\text{mnt}^{2-} = \text{C}_4\text{N}_2\text{S}_2^{2-}$ ) was synthesized [2]. This complex was characterized by IR,  $^{13}\text{C}$ -NMR, EDX and UV-vis spectrometry.

Quantum chemical calculation was made in 6-311++G(2d,2p) and LANL08(f) basis for W by the B3LYP method in gas phase and using PCM model with B3LYP method in the acetonitrile solution. The structures and thermodynamic potentials was calculated for the reduced  $[\text{WO}(\text{mnt})_2]^{2-}$  and oxidized  $[\text{WO}_2(\text{mnt})_2]^{2-}$  forms of tungsten complexes (Fig. 1), triphenylphosphine  $\text{PPh}_3$  and triphenylphosphine oxide  $\text{OPPh}_3$ .  $\Delta H_{\text{red}}^{\text{calc}}$  for the reaction between oxidized form  $[\text{WO}_2(\text{mnt})_2]^{2-}$  and  $\text{PPh}_3$  in the gas phase and in the acetonitrile solution was calculated on the basis of quantum chemical data.



**Fig. 1.** Calculated structure for the oxidized tungsten complex form  $[\text{WO}_2(\text{mnt})_2]^{2-}$

Dissolution enthalpies of the oxidized form in the acetonitrile  $\Delta H_{\text{sol}}([\text{Bu}_4\text{N}]_2[\text{WO}_2(\text{mnt})_2]) = \text{XXX} \text{ kJ}\cdot\text{mol}^{-1}$  and in the acetonitrile solution containing  $\text{PPh}_3$   $\Delta H_{\text{sol+red}}([\text{Bu}_4\text{N}]_2[\text{WO}_2(\text{mnt})_2]) = \text{kJ}\cdot\text{mol}^{-1}$  were determined by the calorimetric experiments. The experimental enthalpy for the reduction reaction  $\Delta H_{\text{red}}^{\text{ex}}$



was calculated by the following equation:  $\Delta H_{\text{red}}^{\text{ex}} = \Delta H_{\text{sol+red}} - \Delta H_{\text{sol}} = \text{ZZZ} \text{ kJ}\cdot\text{mol}^{-1}$

Experimental data as in good accordance with quantum calculations than confirms the models and basis used and allows further use of quantum calculations instead of complicated calorimetric experiments for thermodynamic characterization of oxotransfer processes.

Thus, first the oxotransfer process with synthetic analogue of the tungsten-containing enzymes participation was characterized thermodynamically. Calorimetric experiments and quantum chemical calculations a made for this process, thermodynamic potentials are determined:

$$\Delta H_{\text{sol}} = (70.3 \pm 1.4) \text{ kJ}\cdot\text{mol}^{-1}$$

$$\Delta H_{\text{red}}^{\text{ex}} = (-109 \pm 4) \text{ kJ}\cdot\text{mol}^{-1}$$

$$\Delta H_{\text{red}}^{\text{calc}} = -93.44 \text{ kJ}\cdot\text{mol}^{-1}$$

$$\Delta S_{\text{red}}^{\text{calc}} = -1.16 \text{ J}\cdot\text{mol}^{-1}\cdot\text{K}^{-1}$$

### References

- [1] – Gregory C. Tucci, James P. Donahue, and R. H. Holm. *Inorg. Chem.* **1998**, 37, 1602-1608  
[2] – Das, S.K., Biswas, D., Maiti, R., Sarkar, S. *J. Am. Chem. Soc.* **1996**, 118, 1387-1397.

STUDY OF CRYSTALLIZATION OF GLASSES OF THE  $B_2O_3$ - $La_2O_3$ - $Nb_2O_5$ - $WO_3$ - $Al_2O_3$  SYSTEM

Skovoroda V.A.<sup>1</sup>, Bogdanov O.A.<sup>1,2</sup>

<sup>1</sup>*Saint-Petersburg State Institute of Technology*

<sup>2</sup>*Institute of Silicate Chemistry, I.V. Grebenshchikov RAS*

[veronika-skovoro@mail.ru](mailto:veronika-skovoro@mail.ru)

Niobates [1] and tungstates [2] of rare earth elements are of great interest as materials for photonics. The preparation of such compounds in the course of crystallization of glasses is of great interest, since it allows one to obtain compounds of complex composition at a wide concentration of the initial components. The aim of this work is to study the effect of tungsten oxide on the crystallization properties of glasses of the  $37.5B_2O_3$ - $22.5La_2O_3$ -(40-x) $Nb_2O_5$ -x $WO_3$  system (where x = 0, 10, 15, 20 mol. %).

The charge contains  $H_3BO_3$ ,  $La_2O_3$ ,  $Nb_2O_5$  and  $WO_3$ .  $Al_2O_3$  was introduced from the crucible during cooking over the concentration of the main components. The glass was melted in air at a temperature of 1280 °C in a corundum crucible. The cooking time was 60 minutes.

X-ray phase analysis (XPA) was carried out on a general-purpose X-ray diffractometer "Rigaku Smartlab III" using CuK $\alpha$ -radiation and a D/teX Ultra detector. Heat treatment was carried out in a muffle furnace in the temperature ranges between the glass transition temperature  $T_g$  and the melting temperature  $T_m$ . The holding time for glass crystallization was 6 hours. Scanning electron microscopy was performed using Tescan Vega 3SBH SEM; X-ray spectral microanalysis of the chemical composition was carried out using an Aztec X-Act X-ray energy dispersive microanalyzer (Oxford Instruments). The compositions of glasses obtained in the course of crystallization with different contents of tungsten oxide are presented in table 1.

Content $WO_3$	Oxide	Borate
0 $WO_3$	$LaNbO_6$	$LaNbB_{6.83}O_{7.83}$
10 $WO_3$	$La_{0.5}Nb_{0.9}Al_{0.3}W_{0.4}O_{7.2}$	$La_{0.5}Nb_{0.9}Al_{0.3}W_{0.1}B_{1.9}O_{6.3}$
20 $WO_3$	$La_{1.1}Nb_{0.7}Al_{0.4}W_{0.5}O_{7.2}$	$La_{0.7}Nb_{0.7}Al_{0.4}W_{0.2}B_{1.4}O_{6.5}$
30 $WO_3$	$La_1Nb_{0.5}Al_{0.8}W_{0.4}O_{7.3}$	$La_{0.6}Nb_{0.3}Al_{0.4}W_{0.3}B_{3.3}O_{5.1}$
40 $WO_3$	$Al_2O_3$	$La_{0.6}Al_{0.6}W_{0.5}B_{2.2}O_{6.1}$

**Table 1.** Stoichiometric composition of glass crystallization products at different concentrations of tungsten oxide.

As can be seen, with an increase in the  $WO_3$  concentration, the tungsten content in the formed borates increases, while its concentration in oxides remains constant. As noted above, an increase in the concentration of tungsten leads to an increase in the content of aluminum in the glass and in the products of its crystallization. The aluminum content in oxide crystals increases with increasing tungsten concentration. In borates, the aluminum concentration varies insignificantly and becomes equal to 6 at.%. Only when the niobium oxide is completely replaced. It should be noted that corundum is precipitated as an oxide phase at 40 mol. %  $WO_3$ , which indicates that the  $Al_2O_3$  content in  $La_{0.6}Al_{0.6}W_{0.5}B_{2.2}O_{6.1}$  is limiting.

During the synthesis of glasses of the  $37.5B_2O_3$ - $22.5La_2O_3$ -(40-x) $Nb_2O_5$ -x $WO_3$  system (where x = 10-40 mol.%). In corundum crucibles with increasing tungsten concentration, an increase in the volume of soluble aluminum oxide is observed.

Crystallization of glasses with a tungsten oxide content of 10 to 30 mol.% is characterized by the simultaneous release of  $La_xNb_yAl_zW_tO_3$  oxides and borates of the  $La_aNb_bB_cAl_eBrO_g$  type. This feature of crystallization of the presented systems can be useful in the production of complex tungstates containing rare earth ions and transition metal ions.

#### Bibliography

- [1] Nico C., Monteiro T., Graça M.P.F. *Prog. Mater. Sci. Elsevier Ltd*, **2016**, 80, 1–37.  
 [2] Zhang Q., Meng Q., Tian Y., Feng X., Sun J., Lü S. *J. Rare Earths. The Chinese Society of Rare Earths*, **2011**, 29, 9, 815–821.

Acknowledgments. This work was supported by the Russian Science Foundation (project No. 19-73-10180)

*Slavnov T.D., Egorova E.M., Garkushin I.K.*

Samara State Technical University, Samara, Russia

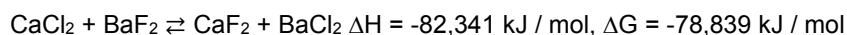
student

[t\\_slavnov@inbox.ru](mailto:t_slavnov@inbox.ru)

The paper describes chemical interaction by the ion balance method in a three-component reciprocal system Ca, Ba || F, Cl. Molten salts containing chlorides and fluorides of alkaline earth metals make it possible to create many valuable salt compositions, in particular, for the isolation and processing of aluminum scrap and for its density separation [1, 2].

For the reactions occurring at the conversion points, according to the data, the enthalpies and Gibbs energies were calculated under standard conditions [3].

For example, for a reaction occurring at the conversion point:



The system was split into simplexes using graph theory, and a phase tree was constructed, consisting of five stable simplexes in the system (Fig. 1).

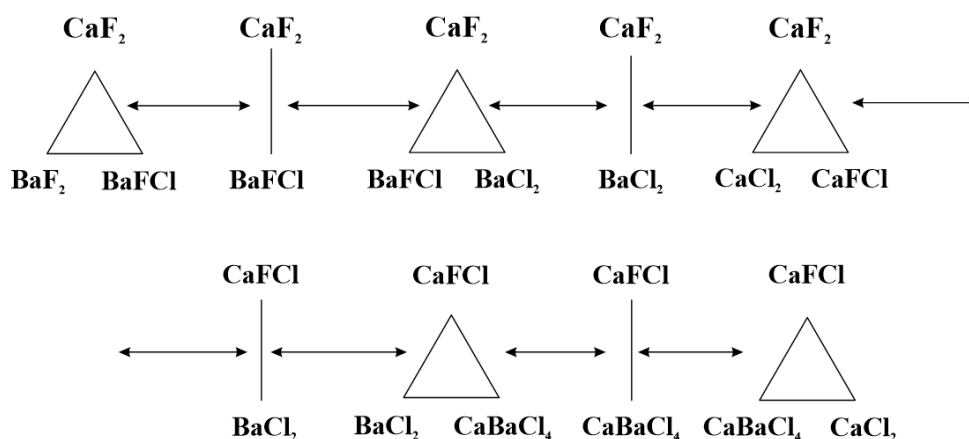


Fig 1. System phase tree

Reactions for all stable simplexes have been described by the ion balance method.

The experimental study of the samples was carried out on a Q-1200 derivatograph at a controlled heating rate of 20° per minute up to 950°C. The investigated sample of the composition 22.5%  $\text{CaF}_2$  and 77.5%  $\text{BaCl}_2$  on the DTA curve showed two peaks corresponding to liquidus and quasi-double eutectic.

#### References

- [1] Sveinbjörnsson D., Christiansen A.S., Viskinde R. etc. J. Electrochem. Soc., **2014**, 161, 9. A1432-A1439.
- [2] Semwal R., Ravi C., Kumar R. etc. J. Org. Chem., **2019**, 84, 2, 792-805.
- [3] Chemical portal Chem.ru link URL: <http://www.chem.msu.su>

# CYCLOMETALATED IRIDIUM (III) COMPLEXES WITH N-BENZYLBENZIMIDAZOLES: SYNTHESIS, STRUCTURE, PHOTOPHYSICAL AND ELECTROCHEMICAL PROPERTIES

*Smirnov D.*<sup>1,2</sup>, *Bezzubov S.*<sup>2</sup>

<sup>1</sup>Department of Chemistry, Lomonosov Moscow State University, Lenin's Hills 1, Moscow 119991, Russia

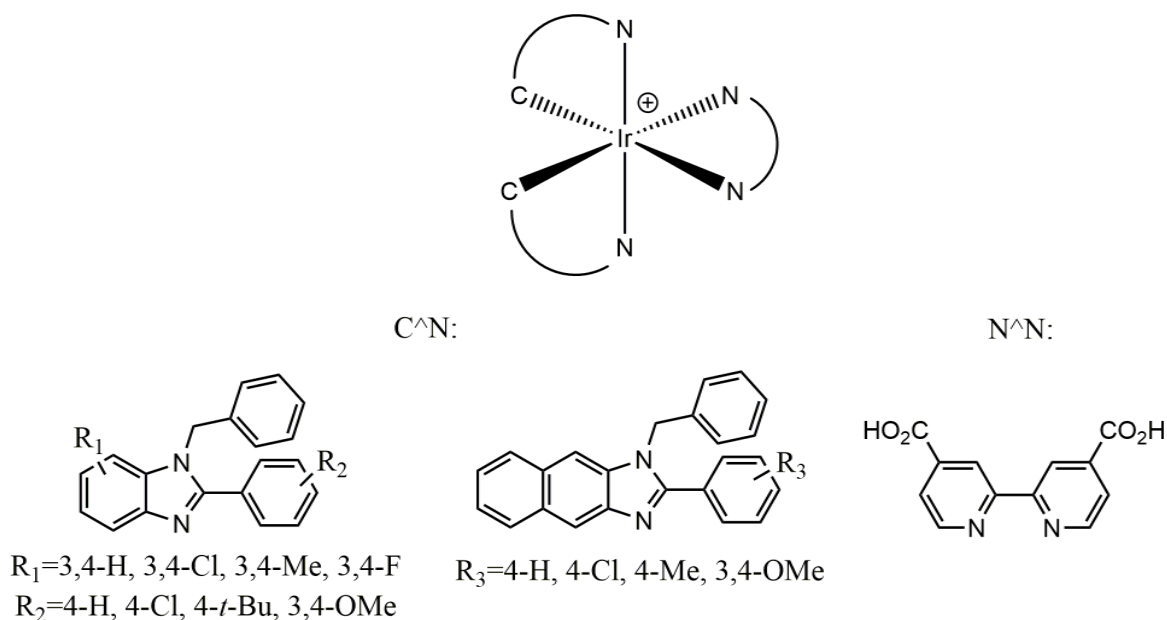
<sup>2</sup> Kurnakov Institute of General and Inorganic Chemistry, Russian Academy of Sciences, Leninskii pr. 31, Moscow 119991, Russia

Student

[danza4077@gmail.com](mailto:danza4077@gmail.com)

Cyclometalated Ir(III) complexes can be considered as a stable replacement for Ru(II) complexes and organic dyes in DSSC. However, low extinction coefficients in visible area of Ir(III) compounds obstruct widespread using in DSSC. N-benzyl-benzimidazoles were chosen as cyclometalated (C<sup>^</sup>N or 'antenna') ligand because of great possible variability of their properties depending on the substituents. So in order to expand variability of possible compounds, complexes with both aryl and benzimidazole substituted fragments have been studied in this work. Exploring these complexes should help to fit DSSC dye requirements such as redox potential and extinction coefficients. 2,2'-Bipyridine based ligands were chosen as 'anchoring' ligands because of successful application in general and most common Ru(II) DSSC dyes.

In this work, we present exhaustive theoretical and experimental study (X-ray, NMR, MS, UV-Vis, CVA, LS) of series of cyclometalated iridium(III) complexes with different 2-aryl-N-benzylbenzimidazoles and 4,4'-dicarboxy-2,2'-bipyridine. (Figure 1).



**Figure 1.** Complexes studied in this work

# POWDER MIXTURES PREPARED UNDER MECHANICAL ACTIVATION FROM AMMONIUM PHOSPHATES AND CALCIUM AND / OR MAGNESIUM ACETATES

*Smirnova N.V.<sup>1</sup>, Safronova T.V.<sup>1</sup>, Kazakova G.K.<sup>1</sup>*

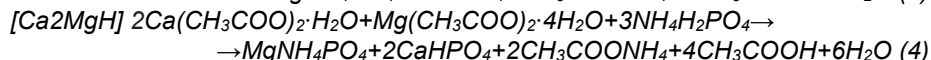
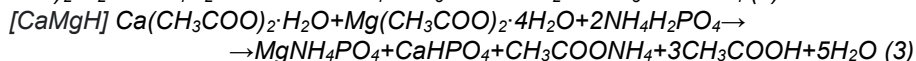
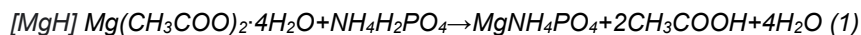
<sup>1</sup>Lomonosov Moscow State University, Moscow Russia

[smi.nv@yandex.ru](mailto:smi.nv@yandex.ru)

Calcium phosphates such as hydroxyapatite, alpha and beta tricalcium phosphates are mainly used in medicine. However, the 2017 it was mentioned about the important role of magnesium ions in our body [1]. The bone remodeling process is based on the interaction of osteoclasts and osteoblasts. Together, they affect the amount of bone tissue. Osteoblasts are involved in the formation of bone tissue, while osteoclasts participate in its destruction. On the one hand, magnesium ions have a positive effect on the activity of osteoblasts, on the other hand, they inhibit the formation of osteoclasts. Also, by replacing calcium cations with magnesium cations in phosphates, it is possible to increase the resorbability of the final material based on calcium phosphates. That's why the main purpose of our work was to synthesize and study the properties of powder mixtures prepared under mechanical activation from ammonium phosphates and calcium and / or magnesium acetates. To achieve this goal, the following tasks were set:

1. Synthesis of powder mixtures using mechanical activation, where calcium and / or magnesium acetates and ammonium phosphate monobasic are taken as reagents;
2. Study of the obtained powder mixtures using XRD, granulometry (measurement of the size of agglomerates), SEM microscopy;
3. Forming and firing of the powder compacts (tablets) based on prepared powder mixtures at different temperatures (800, 900, 1000, 1100 °C);
4. Study of the obtained ceramics using XRD, granulometry (measurement of the size of agglomerates), SEM microscopy.

The calculation of the required amounts of starting materials was carried out on the assuming that the following processes will occur (codes of powders are before reaction):



In the case of the reaction between a mixture of calcium and magnesium acetates and ammonium dihydrogen phosphate (reactions 3 and 4), different Ca/Mg/P molar ratios were taken as 1/1/2, 2/1/3.

According to XRD the only reaction between magnesium acetate and ammonium dihydrogen phosphate (reaction 1) took place during mechanical activation and phase of newberite was detected. In the case of the reaction between ammonium dihydrogen phosphate calcium acetate and/or magnesium acetate the reaction took place partial (reactions 2, 3 and 4). According to the granulometry data, the average size of the agglomerates was 42.7 μm in the case of the reaction between ammonium dihydrogen phosphate and magnesium acetate [powder MgH]. In the case of the reaction between ammonium dihydrogen phosphate and calcium acetate [powder CaH] the average size of the agglomerates was 53.1 μm. In the case of the reaction between dihydrogen phosphate ammonium and calcium and magnesium acetates [powder CaMgH] the average size of the agglomerates was 49.0 μm. which correlates with microscopic data, where the average particle size decreases with increasing magnesium content. According to thermal analysis, the change in mass for the reaction between calcium acetate and ammonium dihydrogen phosphate was 35%, in the case of magnesium acetate - 50%, the same result was obtained for calcium and magnesium acetates. After firing, the corresponding pyrophosphates were obtained (Ca<sub>2</sub>P<sub>2</sub>O<sub>7</sub>, Mg<sub>2</sub>P<sub>2</sub>O<sub>7</sub>, CaMgP<sub>2</sub>O<sub>7</sub>).

Powder mixtures prepared under mechanical activation from ammonium phosphates and calcium and / or magnesium acetates can be used as powder precursors for bioceramics production.

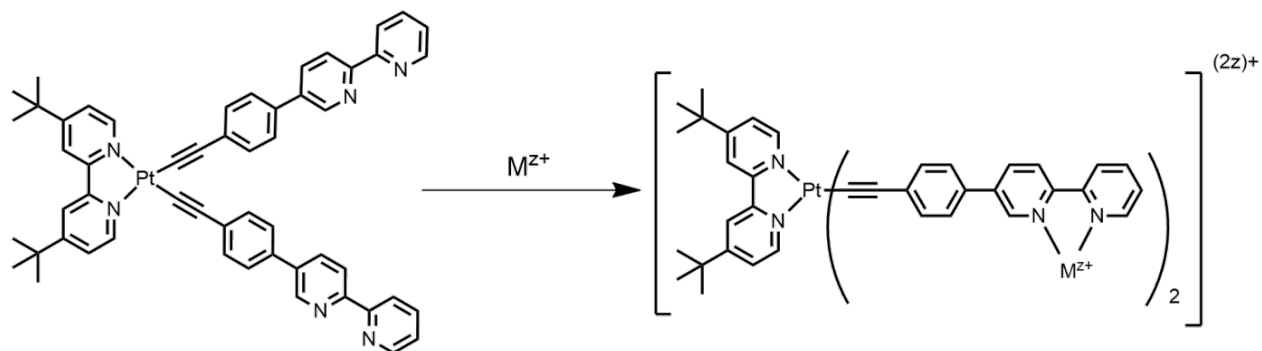
## References

- [1] Kim H.D., Jang H.L., Ahn H. *Biomaterials*, **2017**, *112*, 31-43

Acknowledgements. This work was supported by Russian Foundation for Basic Research (project No 19-38-90274).

Currently, bis-acetylide complexes of platinum(II) with additional donor functions are of great interest. These metalloligands have square-planar geometry and usually exhibit outstanding photophysical properties. These features ensure their active usage as parts of optical devices [1] and luminescent materials [2]. Heterobimetallic systems based on such metalloligands may have interesting physicochemical properties, which depend on the nature of the secondary metal ion and its coordination environment.

In the present work, several heterobimetallic systems based on metalloligand  $[Pt(dtbp)(epbp)_2]$  have been obtained and characterized by polynuclear NMR spectroscopy, ESI+ mass-spectrometry, and IR spectroscopy. Also, photophysical properties of synthesized compounds have been studied.



**Figure 1.** Synthesis of heterobimetallic systems,  $M^{z+}$  is a coordination particle.

#### References

- [1] Wang, C., Zhang, T., Lin W. *Chem. Rev.* **2012**, *112*, 1084–1104  
 [2] Shiotsuka, M., Nishiko, N., Keyaki, K., Nozaki, K. *Dalton Trans.*, **2010**, *39*, 1831–1835

Acknowledgements. The work was carried out with the financial support of the Russian Science Foundation (project 21-13-00052). Characterization of all samples was conducted on the equipment of the Resource Centers of the St. Petersburg State University Science park “Centres for Magnetic Resonance”, “Optical and Laser Materials Research”, “Chemical Analysis and Materials Research”, and “X-ray Diffraction Centers”.



## CLICK CHEMISTRY WITH IRON SANDWICH COMPLEXES

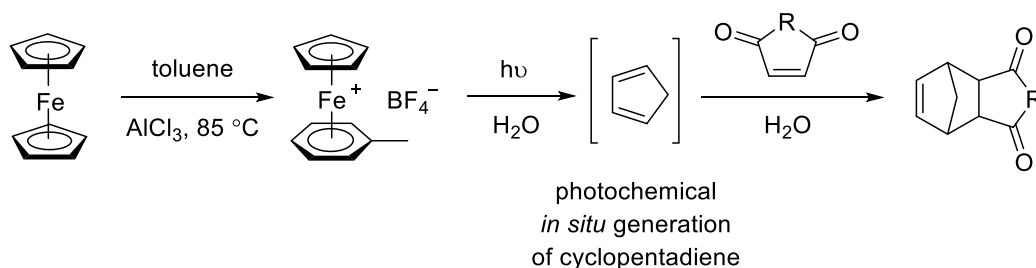
*Sokolov A.S.*<sup>1</sup>, *Perekalin D.S.*<sup>2</sup>

<sup>1</sup>Moscow Institute of Physics and Technology, Moscow, Russia

<sup>2</sup>A.N. Nesmeyanov Institute of Organoelement Compounds of Russian Academy of Sciences, Moscow, Russia  
Student

[sokolov.as@phystech.edu](mailto:sokolov.as@phystech.edu)

Diels-Alder cycloaddition is widely used as non-polar “click” reaction in organic chemistry and biochemistry [1,2]. One of the fastest Diels-Alder reagents is a simple cyclopentadiene. However, its application is limited because it is unstable in the pure form and readily forms a dimer. Herein we present a new approach which allows generation of unstable cyclopentadiene at room temperature by visible light irradiation of its iron complex in water. The generated cyclopentadiene can react with various dienophiles to give the corresponding Diels-Alder adducts.



**Figure 1.** Generation of cyclopentadiene from iron complexes

### References

- [1] Levandowski B.J., Raines R.T., *Chem. Rev.* 2021 DOI: 10.1021/acs.chemrev.0c01055  
[2] Patterson, D. M., Nazarova, L. A., Prescher, J. A., *ACS Chemical Biology*, 2014, 9, 592–605.

Acknowledgements. This work was supported by Russian Science Foundation (grant 17-73-30036).

# STUDY OF THE EFFECT OF THE DOPING ELEMENT ON THE STRUCTURE AND PROPERTIES OF BARIUM HEXAFERRITE

*Solizoda I.A.<sup>1</sup>, Zhivulin V.E.<sup>1</sup>, Trofimov E.A.<sup>1</sup>, Vinnik D.A.<sup>1</sup>*

<sup>1</sup>South Ural State University (National Research University), 454080, Lenin ave. 76, Chelyabinsk, Russia  
[Solizodai@susu.ru](mailto:Solizodai@susu.ru)

Monophase ceramic samples such as  $\text{BaFe}_{12}\text{O}_{19}$ ,  $\text{BaFe}_{11}\text{AlO}_{19}$ ,  $\text{BaFe}_{11}\text{TiO}_{19}$  and  $\text{BaFe}_{11}\text{Al}_{0.5}\text{Ti}_{0.5}\text{O}_{19}$  and were obtained by solid-state synthesis at a temperature and ferritization time of 1350 °C and 5 h, respectively. The following reagents were selected as starting materials: iron (III) oxide, aluminum oxide, titanium (IV) oxide, and barium carbonate.

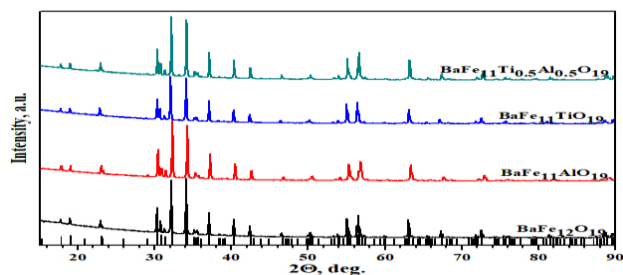
The effect of Al, Ti, and Al+Ti substitution on the crystal structure of the powders was studied by X-ray phase analysis (XRD). The elemental composition was measured using a scanning electron microscope with an energy-dispersion analyzer (SEM-EDS). The Curie temperature was determined using the differential scanning calorimetry (DSC) method. Table 1 shows the results of the elemental analysis, according to energy-dispersion spectroscopy.

**Table 1.** Elemental composition of samples in atomic percentages

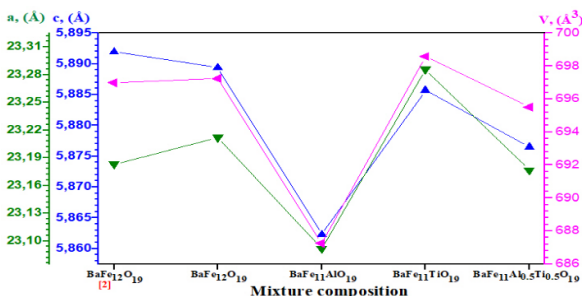
№	Chemical composition	%					Chemical composition according to EDX data
		Ba	Fe	Al	Ti	O	
1	$\text{BaFe}_{12}\text{O}_{19}$	3,29	39,41	-	-	57,16	$\text{BaFe}_{12}\text{O}_{19}$
2	$\text{BaFe}_{11}\text{AlO}_{19}$	3,44	37,89	3,32	-	55,27	$\text{BaFe}_{11,03}\text{Al}_{0,97}\text{O}_{19}$
3	$\text{BaFe}_{11}\text{TiO}_{19}$	3,38	36,11	-	3,4	57,12	$\text{BaFe}_{10,97}\text{Ti}_{1,03}\text{O}_{19}$
4	$\text{BaFe}_{11}\text{Al}_{0.5}\text{Ti}_{0.5}\text{O}_{19}$	3,45	37,69	1,71	1,82	55,33	$\text{BaFe}_{10,97}\text{Al}_{0,5}\text{Ti}_{0,53}\text{O}_{19}$

The results of X-ray phase analysis showed that all samples are monophase (Fig. 1). The calculation of the crystal lattice constant of the samples (a and c) and the volume of the unit cell (V) was performed using the Rigaku PDXL software package. As can be seen from Figure 2, the values of the crystal lattice parameters (a, c, and V) differ for all the samples obtained. The change in the lattice parameters is associated with a change in the ion radius of the doping element [ $\text{Fe}^{3+}$  (0.063 nm),  $\text{Al}^{3+}$  (0.053 nm),  $\text{Ti}^{4+}$  (0.056 nm) [1].

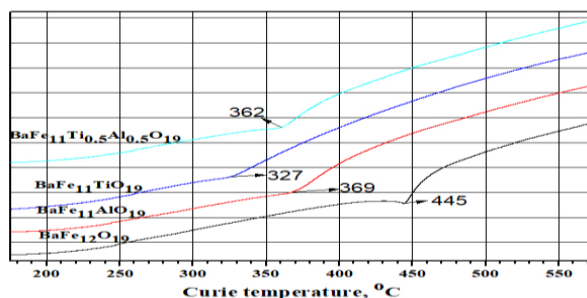
It is known that when a ferromagnet passes through the Curie temperature, its heat capacity changes abruptly. The Curie temperature was measured by the DSC method for all the samples obtained. The maximum Curie temperature was recorded for barium hexaferrite  $\text{BaFe}_{12}\text{O}_{19}$  and was 445 °C (Fig. 3).



**Figure 1.** X-ray images of samples obtained at a temperature of  $T=1350$  °C (the strokes indicate the literature data [2])



**Figure 2.** Dependence of the crystal lattice parameters on the alloying element



**Figure 3.** Dependence of the Curie temperature on the alloying element

## References

- [1] Shannon R., D. Acta Crystallographica Section A. 1976, 32(5) 751–767  
[2] Obradors X., Collomb A. J. Solid State Chem. 1985, 56, 171-181

Acknowledgements. The reported study was funded by RFBR (project number 20-38-70057) and President's grants for young doctors of science (MD-5612.2021.4).

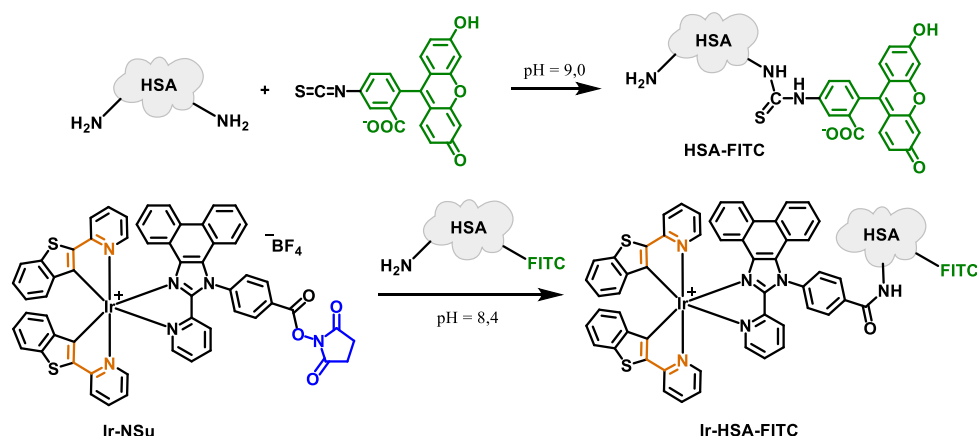
# SIMULTANEOUS FLIM-PLIM IMAGING USING DUAL pH-O<sub>2</sub> MOLECULAR PROBE

*Solomatina A.I.<sup>1</sup>, Chelushkin P.S.<sup>1</sup>, Tunik S.P.<sup>1</sup>*

<sup>1</sup>Saint Petersburg State University, Saint Petersburg, Russia  
PhD, Assistant educator  
[nastisol@gmail.com](mailto:nastisol@gmail.com)

Luminescent bioimaging is a rapidly developing and highly promising method for the non-invasive visualization of biological systems [1]. Luminescent compounds can be sensitive to corresponding media parameters and possess specific photophysical characteristics, e.g. lifetime of excited state (LT), in definite conditions. New microscopy methods PLIM and FLIM (phosphorescence and fluorescence lifetime imaging microscopy) allow mapping of the microscopic image according to the lifetime of the sensor probe in each pixel. Using two sensors conjugated with some vector can afford us to get unique information on these parameters in each point of the image and therefore monitor and study processes in living cells and tissues in real-time.

Herein, we report the first example of simultaneous PLIM-FLIM cellular imaging using a dual pH-O<sub>2</sub> probe (Figure 1). The probe was built on the basis of HSA (human serum albumin), the most common protein in the human body, which is known and widely used as the carrier for hydrophobic compounds in cells [2]. Fluorescein (FITC) and iridium complex (Ir) were substantially conjugated to HSA. Fluorescein, fluorophore, possesses strong pH dependency of photophysical properties upon acidity in the physiological pH region (4,5 - 8,5), whereas the triplet emission intensity of Ir-complex is highly sensitive to the presence of molecular oxygen. Thus, the dual conjugate Ir-HSA-FITC is simultaneously sensitive to pH and O<sub>2</sub>.



**Figure 1.** Synthesis of the dual probe Ir-HSA-FITC.

Calibration curves of singlet emission lifetime upon pH and of triplet emission lifetime upon [O<sub>2</sub>] were measured in buffer solution and growing media. The conjugate does not demonstrate cytotoxicity on CHO cells up to 150 μM. The compound localizes in lysosomes and possesses very low FITC emission intensity, which can be explained by quenching of the fluorescence in highly acetic conditions of lysosomes. Ir phosphorescence is sensitive to molecular oxygen concentration, which allows using the sensor as a pH-O<sub>2</sub> probe for simultaneous PLIM-FLIM imaging.

## References

- [1] Chelushkin P.S., Tunik S.P., Progress in Photon Science. Recent Advances. Springer Series in Chemical Physics, Springer **2019**, 119, 109-128
- [2] Solomatina A.I., Baigildin V.A., Zhukovsky D.D., Krupenya D.V., Koshel E.I., Shcheslavskiy V.I., Tunik S.P., Chelushkin P.S. *Colloid Polym. Sci.* **2019**, 297, 325-337

**Acknowledgements.** This work was supported by Russian Science Foundation grant 19-13-00132. Investigation was carried out using scientific equipment of St. Petersburg State University Research Park: Center for Magnetic Resonance, Center for Optical and Laser Research, Center for Chemical Analysis and Materials Research, and Centre for X-ray Diffraction Studies.

LUMINESCENT METAL-ORGANIC FRAME STRUCTURES BASED  
ON RARE EARTH TEREPHTHALATES (Eu<sub>x</sub>Lu<sub>1-x</sub>)<sub>2</sub>(1,4-BDC)<sub>3</sub>·yH<sub>2</sub>O

Sosnovsky V.B.<sup>1</sup>, Mereshchenko A.S.<sup>2</sup>, Vidyakina A.A.<sup>2</sup>, Nosov V.G.<sup>2</sup>, Zheglov D.A.<sup>1</sup>,  
Ostrosablin A.N.<sup>1</sup>, Sysoeva A.A.<sup>1</sup>, Zaverukhin S.E.<sup>1</sup>.

<sup>1</sup> Sirius University of Science and Technology, 1 Olympic Ave, Sochi 354340, Russia

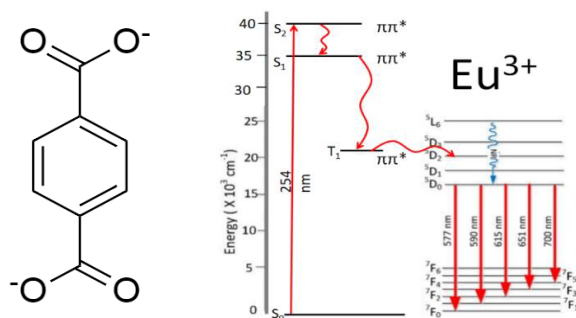
<sup>2</sup> Saint-Petersburg State University, 7/9 Universitetskaya emb., St. Petersburg 199034, Russia

Student

[vladimir2003sosnovskii@gmail.com](mailto:vladimir2003sosnovskii@gmail.com)

Luminescent materials are widely used in science, technology, and medicine. Many compounds of rare earth metals have pronounced luminescent properties, however, due to the fact that f-f electronic transitions are characterized by low extinction coefficients, their direct excitation is often difficult. One of the solutions to this problem is the use of a sensitizer that efficiently absorbs light followed by energy transfer to the rare-earth metal ion and radiative transition to the ground state.

In this work, we synthesized metal-organic frameworks based on mixed terephthalates of optically inactive lutetium (III) with luminescent europium (III) ions. Terephthalate ions intensively absorb ultraviolet light promoting them into a singlet electronic excited state, which then undergoes to the triplet electronic excited state by intersystem crossing. Excitation of europium (III) ions occurs through energy transfer from the triplet state of the terephthalate anion to the f-f excited electronic state of Eu<sup>3+</sup> ion and is followed by luminescence (Fig. 1).



**Figure 1.** Terephthalate ion and Jablonski diagram of europium (III) terephthalate.

The structure and luminescent properties were studied using photoluminescence spectroscopy, XRD powder diffraction, X-ray energy dispersive spectroscopy (EDX), and Raman spectroscopy. The analysis of EDX spectra showed that the ratios of rare earth elements correspond to initial concentrations of their chlorides taken for the synthesis. The X-ray diffraction analysis demonstrated that Eu-Lu mixed terephthalates are isostructural to Tb<sub>2</sub>(1,4-BDC)<sub>3</sub>·4H<sub>2</sub>O at a low concentration of lutetium (III), and a new crystalline phase, probably anhydrous terephthalate, is formed at a high concentration of lutetium (III). Upon 280-nm excitation, luminescence spectra of all samples containing Eu<sup>3+</sup> contained pronounced bands of Eu<sup>3+</sup> radiative transitions.

Mixed Eu-Lu terephthalates at low concentrations (< 4 at.%) of europium mainly crystallize in the form of anhydrous terephthalate Ln<sub>2</sub>(1,4-BDC)<sub>3</sub>, which is isostructural to Er<sub>2</sub>(1,4-BDC)<sub>3</sub>, and at high concentrations of europium (> 10 at.%) - in the form of crystalline hydrate Ln<sub>2</sub>(1,4-BDC)<sub>3</sub>·4H<sub>2</sub>O, which is isostructural Tb<sub>2</sub>(1,4-BDC)<sub>3</sub>·4H<sub>2</sub>O. In the range of europium concentrations from 4 to 10 at.%, a mixture of the two abovementioned phases crystallizes. Luminescence intensity non-monotonously depends on the Eu (III) concentration: the steep luminescence intensity increase up to 10 at.% of Eu(III) is followed by its gradual reduction up to 100 % Eu(III). The shape of the emission spectrum is significantly changed in the range of 1-10 % at.% of Eu(III).

We revealed that heavy metal ions such as Cu<sup>2+</sup>, Cr<sup>3+</sup>, Fe<sup>3+</sup>, Pb<sup>2+</sup> quench the luminescence of the synthesized mixed terephthalates, which makes it possible to use these compounds as luminescent sensors. The introduction of lutetium into europium terephthalate reduces the concentration threshold of detection of heavy metal ions and, thus, improves sensory properties.

Also, in this work, we developed new luminescent paints based on the europium and terbium (III) terephthalates, which glow upon UV-C ultraviolet irradiation. Using designed paints, the picture describing the application of rare earth terephthalates was created.

Acknowledgements. The measurements were performed at the Research Park of Saint-Petersburg State University ("Magnetic Resonance Research Centre", "SPbU Computing Centre", "Cryogenic Department", "Interdisciplinary Resource Centre for Nanotechnology", "Centre for X-ray Diffraction Studies" and "Centre for Optical and Laser Materials Research"). The reported study was funded by RFBR, project number 20-33-70025.

## SYNTHETIC APPROACHES TO NEW REDOX-ACTIVE CARBENE LIGANDS

*Spiridonov K.A.*<sup>1,2</sup>, *Nikovskiy I.A.*<sup>1</sup>, *Pavlov A.A.*<sup>1</sup>, *Nelyubina Yu.V.*<sup>1,3</sup>, *Polezhaev A.V.*<sup>1,3</sup>

<sup>1</sup>A.N. Nesmeyanov Institute of Organoelement Compounds, Russian Academy of Sciences, Moscow, Russia

<sup>2</sup>Moscow State University, Moscow, Russia

<sup>3</sup>Bauman Moscow State Technical University, Moscow, Russia

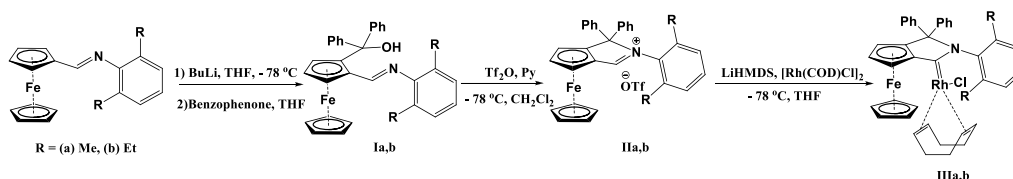
<sup>4</sup>Moscow Institute of Physics and Technology (National Research University), Dolgoprudnyi, Moscow region, Russia

Student

[kirik7380@gmail.com](mailto:kirik7380@gmail.com)

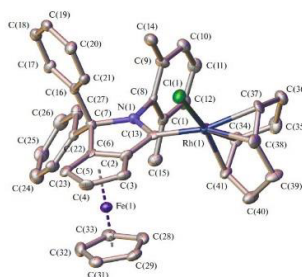
The development of advanced smart materials requires introduction, into the molecules, of various functional groups able to change their state in a predicted manner under a particular targeted external action (so-called molecular switches) [1–2]. A simple way of such switching is the reversible change in the oxidation state of one of the atoms in the molecule under the action of electrical potential or an oxidant/reductant [3].

A number of carbenes and carbene-based complexes containing a ferrocene moiety were reported in the literature [4]. It is noteworthy that in most compounds of this type, the ferrocenylmethyl substituent is located on the nitrogen atom and is separated from the carbene carbon atom by several non-conjugated bonds [4]. As a result, oxidation or reduction of the ferrocene moiety has virtually no effect on the electron-donor ability of the ligand, which makes this synthetic design inappropriate for redox-switchable systems in which the redox moiety is supposed to directly affect the electron-donor ability of the ligand. We developed a facile synthetic route to prepare N-heterocyclic carbenes and their complexes containing an annulated ferrocenyl moiety for their subsequent use in redox-switchable catalysis (Fig. 1) [5].



**Figure 1.** Three-step synthesis of new redox-active rhodium complexes.

All compounds were characterized by multinuclear NMR spectroscopy, elemental analysis and X-ray diffraction analysis (Fig. 2). Resulting complexes were tested in catalysis of alkyne polymerization and hydroformylation.



**Figure 2.** General view of complex IIIa with atoms being represented by thermal ellipsoids ( $p = 50\%$ ).

Analysis of structural data and shifts of <sup>13</sup>C NMR signals of carbene carbon atoms in such complexes shows that the electron-donor properties of carbene ligands in the complexes occupy an intermediate position between those of traditional imidazolium N-heterocyclic carbenes and cyclic alkyl(amino) carbenes CAACs [5].

### References

- [1] Canary J.W., *Chem. Soc. Rev.* **2009**, 38, 3, 747-756
- [2] Sivaev I., *Molecules* **2017**, 22, 12, 2201
- [3] Wang X., Song S., *Chem. Soc. Rev.* **2020**, 49, 3, 736-764
- [4] Peris E., *Chem. Rev.* **2018**, 118, 19, 9988-10031
- [5] Nikovskii I.A., *Rus. J. Coord. Chem.* **2021**, 47, 2, 117-126

# INVESTIGATION OF THE PROPERTIES OF TITANIUM SUBSTITUTED BARIUM HEXAFERRITE

Vinnik D.A.<sup>1</sup>, Zhivulin V.E.<sup>1</sup>, Uchaev D.A.<sup>1</sup>, Gudkova S.A.<sup>1</sup>, Starikov A.Yu.<sup>1</sup>, Trukhanov S.V.<sup>2,3</sup>,  
Turchenko V.A.<sup>1,4,5</sup>, Zubar T.I.<sup>1,2</sup>, Trukhanov A.V.<sup>1,2,3</sup>

<sup>1</sup>South Ural State University, Chelyabinsk, Russia

<sup>2</sup>SSPA "Scientific and Practical Materials Research Centre of NAS of Belarus", Minsk, Belarus

<sup>3</sup>National University of Science and Technology MISiS, Moscow, Russia

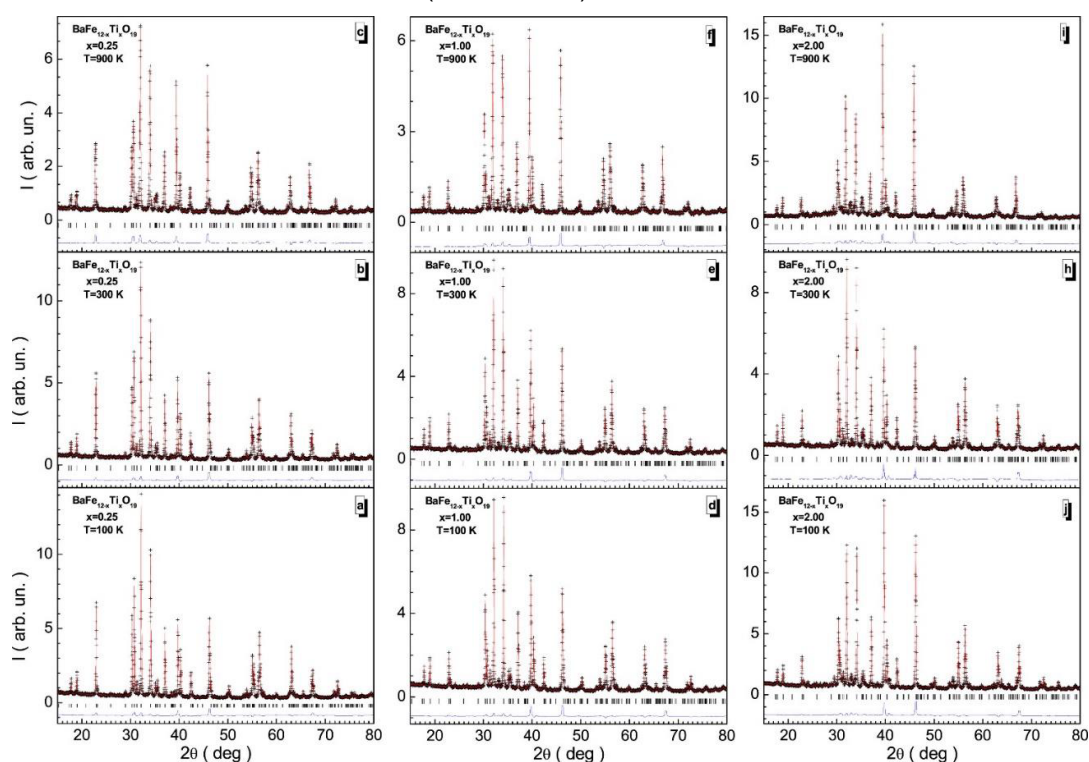
<sup>4</sup>Frank Laboratory of Neutron Physics, Joint Institute for Nuclear Research, Dubna, Russia

<sup>5</sup>Donetsk Institute of Physics and Technology named after O.O. Galkin of the NASU, Kiev, Ukraine

Postgraduate Student

[starikov-andrey@mail.ru](mailto:starikov-andrey@mail.ru)

Among all ferrites, the most widespread and used are M-type barium and strontium hexaferrites. M-type barium hexaferrite  $\text{BaFe}_{12}\text{O}_{19}$  is characterized by a hexagonal unit cell similar to the magnetoplumbite structure. Substitution of the  $\text{Fe}^{3+}$  iron cations with various cations that satisfy the dimensionality requirement is the optimal way to control the physicochemical properties of ferrites. The  $\text{Ti}^{4+}$  titanium substituted barium hexaferrites are very promising for use as the microwave absorbing materials [1-2]. In this work, titanium is used as the substitute material.  $\text{BaFe}_x\text{Ti}_x\text{O}_{19}$  ( $x = 0.25 \div 2.00$ ).



**Figure 1.** X-ray diffraction patterns and their Rietveld refinement for the  $\text{BaFe}_{12-x}\text{Ti}_x\text{O}_{19}$  samples with  $x = 0.25$  (left panel); 1.00 (central panel) and 2.00 (right panel) at  $T = 100$  K (a, d, j); 300 K (b, e, h) and 900 K (c, f, i).

The crosses show the experimental data. The top red solid line is a fitting curve. The bottom blue line is a difference curve. Vertical bars define the Bragg's positions.

The titanium doped  $\text{BaFe}_{12-x}\text{Ti}_x\text{O}_{19}$  ( $x = 0.25 \div 2.00$ ) M-type barium hexaferrite solid solutions were obtained using conventional ceramic technology. The phase composition, crystal structure and unit cell lattice constants were refined by the Rietveld method using powder XRD data up to  $T = 900$  K.

## References

- [1] Wang L., Yu H., Ren X., Xu G. *J. Alloys Compd.* **2014**, *588*, 212–216
- [2] Verma S., Pandey O.P., Paesano Jr. A., Sharma P. *J. Alloys Compd.* **2016**, *678*, 284-289

Acknowledgements. This work was supported by RFBR (project number 20-38-70057) and President's grants for young doctors of science (MD-5612.2021.4).

# IONIC MOLECULAR INTERACTIONS IN THREE-COMPONENT SOLUTIONS OF CADMIUM IODIDE IN *N*-METHYLPYRROLIDONE IN THE PRESENCE OF IONS OF ALKALINE AND ALKALINE-EARTH METALS

Starodub A.N.<sup>1</sup>, Novikova S.N.<sup>1</sup>, Rassokhina L. Yu.<sup>1</sup>, Novikov A. N.<sup>1</sup>,  
Vasilyov V.A.<sup>2</sup>, Solovyov S.N.<sup>2</sup>, Rakhmanova P.A.<sup>2</sup>

<sup>1</sup>Novomoskovsk Institute, Mendeleev University of Chemical Technology, Novomoskovsk, Russia

<sup>2</sup>Mendeleev University of Chemical Technology. Moscow, Russia

Student

[nas.starodub2013@yandex.ru](mailto:nas.starodub2013@yandex.ru)

The heat capacities ( $C_p$ ) and densities ( $\rho$ ) of three-component solutions NaI–CdI<sub>2</sub>–*N*-methylpyrrolidone (NMP), KI–CdI<sub>2</sub>–NMP, RbI–CdI<sub>2</sub>–NMP, BaI<sub>2</sub>–CdI<sub>2</sub>–NMP, at 298.15 K are investigated via calorimetry and densimetry.

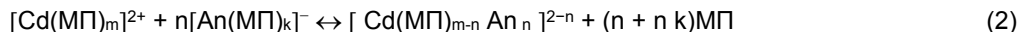
The heat capacity ( $C_p$ ) of solutions was measured using a LKB 8700 calorimeter, a detailed description of which was given in [1, 2]. A 100 cm<sup>3</sup> calorimetric glass vessel equipped with a heater, a thermistor, and a gold stirrer was fastened onto the lid of the chromiumplated brass calorimetric jacket and placed into a water thermostat with  $\Delta T \pm 1 \times 10^{-3}$  K precision of temperature maintenance. The thermistor (at 298.15 K, it had a resistance of 1967.7815  $\Omega$  and a temperature coefficient of  $\sim 80$   $\Omega/K$ ) of this calorimeter was included into one branch of a Wheatstone bridge operating in combination with a Hewlett-Packard 419A electronic galvanometer. To convert the readings of this thermistor into the thermodynamic scale of temperatures, it was calibrated against a TSPN-1 reference platinum resistance thermometer. The thermometric sensitivity of this setup was  $5 \times 10^{-5}$  K. The heater was supplied with a calibrated amount of electrical power (the current source power ranged from 20 to 500 mW, and the reproducibility of heating time was  $1 \times 10^{-3}$  s). The drop in voltage on the calorimeter heater was measured with a potentiometer at a precision of 20  $\mu V$ . The precision of measurements for  $C_p$  was less than  $\pm 2 \times 10^{-3}$  J/(g K). The density of the solutions ( $\rho$ ) was studied on a precision densimeter unit [3] at a precision of  $\pm 1 \times 10^{-5}$  g/cm<sup>3</sup>.

Based on the experimental data for  $C_p$  and  $V$ , additivity coefficients  $\delta_C$  and  $\delta_V$  were determined using the equation

$$\delta_Y = \frac{Y_{\text{exp.}} - Y_{\text{add}}}{Y_{\text{add}}} 100\%, \quad (1)$$

where  $Y_{\text{exp}}$  are the experimental values of the  $C_p$  or  $V$  of three-component solutions;  $Y_{\text{add}}$  are the additive values of the  $C_p$  or  $V$  of solutions, calculated using the literature data on the properties of binary solutions.

The dissolution of cadmium salts in NMP is accompanied by the formation of solvate complexes, acido complexes, and nonuniform complexes with a variety of ligands, which eventually results in the establishing of equilibrium:



where  $\text{An}^-$  is an anion of electrolyte.

The stability of these complexes is determined by the chemical nature of the solvent (mainly its polarity and donating ability) and features of the solvation of the complexing ion and ligand. In aprotic dipolar solvents, where anions are solvated less than cations [4], adding a second electrolyte with the same anion strengthens the desolvation of cations and shifts equilibrium (2) toward the formation of acido complex. In [3], we showed that the processes of desolvation lower the  $C_p$  and raise the  $V$  of a system. The process of resolution is in turn typical of systems with great differences between the enthalpies of solvation of ions, accompanied by opposite changes in  $C_p$  and  $V$ .

Values  $\delta_C < 0$  and  $\delta_V > 0$ , testifying to the predominance of the formation of acidocomplexes in all of the investigated systems. Even in the solutions NaI–CdI<sub>2</sub>–NMP, KI–CdI<sub>2</sub>–NMP, and RbI–CdI<sub>2</sub>–NMP, where the NMP molecules are also redistributed in favor of the better solvating Cd<sup>2+</sup> cation and the effect of complexation is largely compensated for,  $\delta_C$  and  $\delta_V$  do not change sign, and they remain relatively high in their absolute values.

## References

- [1] Medvedev V. A., Efimov M. E. *Russ. J. Phys. Chem.* **1975**, *49*, 1324-1329
- [2] *Experimental Methods of Solution Chemistry: Spectroscopy and Calorimetry*, Ed. by I. S. Perelygin, L. L. Kimtis, V. I. Chizhik, (Nauka, Moscow, 1995), p. 380
- [3] Rassokhina L. Yu., Novikov A. N. *Russ. J. Phys. Chem. A.* 2015, *89*, 2226-2231
- [4] Gutman V. *Coordination Chemistry in Nonaqueous Solutions* (Springer, Vienna, 1968) p. 484

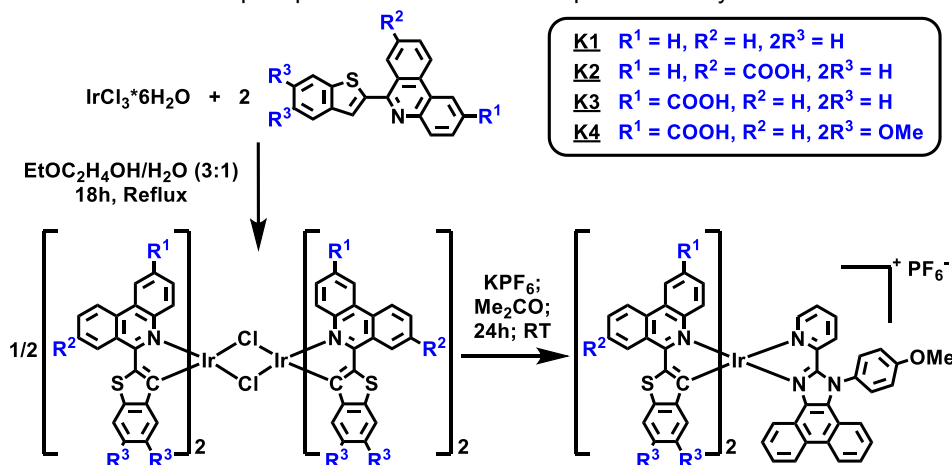
# IRIDIUM(III) COMPLEXES WITH DIFFERENT N<sup>4</sup>C LIGANDS AS MOLECULAR OXYGEN SENSORS

*Stashchak V.S.*<sup>1</sup>, *Kritchenkov I.S.*<sup>1</sup>

<sup>1</sup>Saint Petersburg State University, Saint Petersburg, Russia  
Student  
[st076141@student.spbu.ru](mailto:st076141@student.spbu.ru)

Imaging of oxygenation level is very important field of research, because tissue hypoxia can be reason or marker of different pathological processes including cancer. One of the most perspective methods in bioimaging is PLIM (phosphorescence lifetime imaging). Although there are few methods of oxygen imaging, only luminescent methods are able to measure oxygenation at cellular and subcellular level. In this methods, phosphorescent transition metal complexes are commonly used as molecular oxygen probes, due large Stokes shifts, long lifetime values and triplet nature of excited states, what results in ability for O<sub>2</sub>-quenching of their emission, as well as spectral and/or time-gated separation of phosphorescence from autofluorescence of biomolecules.<sup>[1]</sup> Many octahedral Iridium (III) complexes meet such requirements for phosphorescence sensors as high sensibility for oxygen, emission in red or near-infrared (NIR) region, solubility in biological environment, biocompatibility, low cytotoxicity, redox and photobleaching stability.<sup>[2]</sup> That is why in our research we focused on study of cyclometallated Ir(III) phosphorescent complexes.

In this work a series of 4 novel phosphorescence iridium complexes was synthesized.



**Figure 1.** Synthesis of Iridium complexes

The compounds under study were fully characterized by a set of modern methods of analysis. These complexes exhibit effective emission in NIR region with quantum yields up to 30% in solution. Study of their emission in aerated and deaerated solutions made it possible to choose complex **K4** as most effective O<sub>2</sub>-sensor in this series, as it showed almost 8-fold response to the presence of O<sub>2</sub>.

## References

- [1] T. Yoshiharaa, Yo. Hirakawa, M. Hosakac, M. Nangakub, S. Tobitaa. *J. Photochem. Photobiol. C: Photochem. Rev.* **2017**, 30, 71–95
- [2] Youngmin You. *Curr. Opin. Chem. Biol.* **2013**, 17, 699–707

Acknowledgements. This work was supported by RSF (grant number 18-73-10021), NMR and ESI-MS analysis was performed using the equipment of the Centers for Magnetic Resonance and for Chemical Analysis and Materials Research (Research Park of St. Petersburg State University).



# SYNTHESIS AND CRYSTAL STRUCTURE OF A NEW POTASSIUM FLUOROTRIFLUOROACETATOMETALATES FAMILY FOR LANTHANIDES

*Steshenko D.A.<sup>1</sup>, Boltkov E.D.<sup>1</sup>, Glazunova T.Y.<sup>1,2</sup>, Lermontova E.H.<sup>2</sup>*

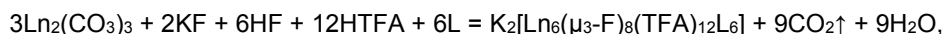
<sup>1</sup>Moscow State University, Moscow, Russia

<sup>2</sup>Kurnakov Institute of General and Inorganic Chemistry of Russian Academy of Sciences  
Student

[dmitrii.steshenko@chemistry.msu.ru](mailto:dmitrii.steshenko@chemistry.msu.ru)

Last year a new family of sodium fluorotrifluoroacetatometalates for lanthanides was reported [1]. This year a family of potassium fluorotrifluoroacetatometalates for a row of REE was investigated.

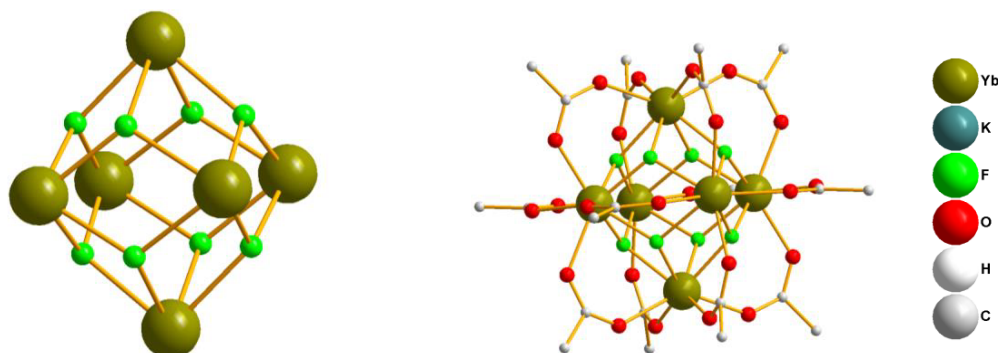
Potassium fluorotrifluoroacetatometalates for REE can be synthesized by dissolving REE carbonates in 99% trifluoroacetic acid with adding of solution KF in 50% HF so that the molar ratio of K:Ln:F is 1:3:4 correspondingly. Forming amorphous precipitate recrystallizes to form bulk transparent crystals.



Reaction.

Compounds' crystal structure was described with the help of XRC. It was found, that during one synthesis few polymorphic modifications of potassium fluorotrifluoroacetatometalates could form for the row of REE (Nd, Eu, Dy, Er, Yb, Lu). Three rows of isostructural compounds were determined: triclinic  $\text{K}_2[\text{Nd}_6(\mu_3\text{-F})_8(\text{TFA})_{12}(\text{H}_2\text{O})_4(\text{HTFA})_2]$ ; triclinic  $\text{K}_2[\text{Ln}_6(\mu_3\text{-F})_8(\text{TFA})_{10}(\text{TFA})_2(\text{H}_2\text{O})_6]$ , Ln= Dy, Er, Yb, Lu; monoclinic  $\text{K}_2[\text{Ln}_6(\mu_3\text{-F})_8(\text{TFA})_{12}(\text{H}_2\text{O})_6]$ , Ln= Eu, Dy, Yb.

In all structures, there is an anionic fragment  $[\text{Ln}_6(\mu_3\text{-F})_8(\text{TFA})_{12}\text{L}_6]$ , L= H<sub>2</sub>O, HTFA. Its core consists of six independent metal atoms located at the vertices of an almost correct octahedron with a tridentate fluorine atom located above each face. Each two-lanthanide atoms are also connected by anions of trifluoroacetic acid.



In triclinic modification anionic fragments are connected through potassium ions to form chains. In monoclinic modification anionic fragments are connected through potassium ions to form layers.

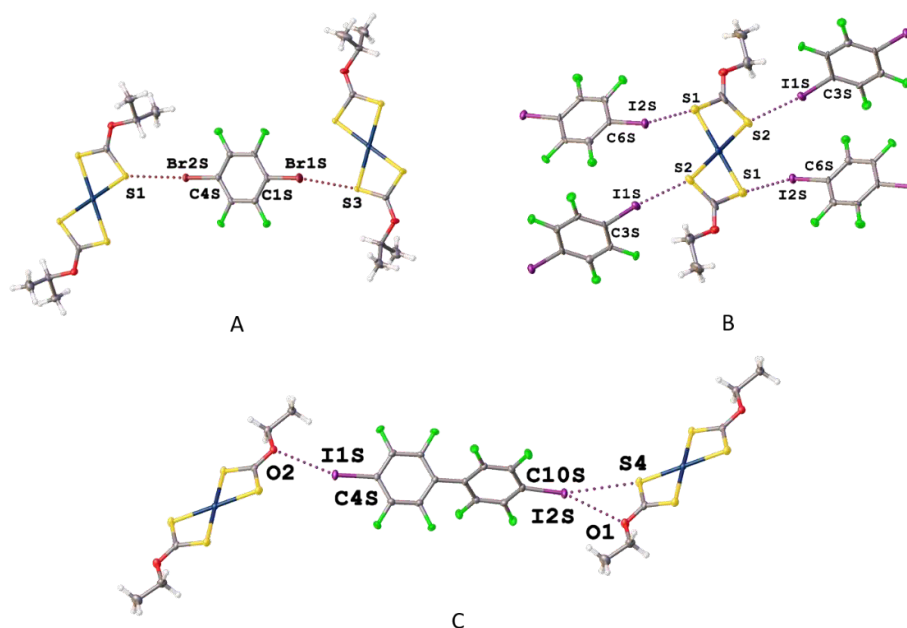
## References

[1] Boltkov E.D., Glazunova T.Y., Belousov Y.A., Kiskin M.A. // Actual problems of inorganic chemistry. Moscow. 13-15 of November 2020. p.p. 170-171

Acknowledgements. This work was supported by Russian Foundation for Basic Research 19-03-01059

The study of the nature of noncovalent interactions involving metal complexes is a rapidly developing interdisciplinary area that combines coordination, organic, quantum, and organometallic chemistry. The discovery of new types of noncovalent contacts led to the creation of new catalytic systems, effective conducting, magnetic and luminescent materials. In the field of crystal engineering and supramolecular chemistry, the concept of noncovalent bonding is extensively used to construct materials featuring desired properties.

Halogen bonding (XB) involving nucleophilic sulfur centers was previously described for square-planar transition metal complexes featuring dithiocarbamate and dithiocarbonate ligands [1–2]. In the present study, two dithiocarbonate platinum(II) complexes were synthesized, viz.  $[\text{Pt}(\text{S}_2\text{COEt})_2]$  and  $[\text{Pt}(\text{S}_2\text{CO}^i\text{Pr})_2]$ . The obtained metal complexes were co-crystallized with iodine- and bromo-substituted perfluoroarenes, forming corresponding supramolecular adducts, which structures were studied by single-crystal X-ray diffraction (XRD) (Fig. 1).



**Figure 1.** The Br/I $\cdots$ S XBs in the XRD structures of the obtained adducts: A –  $[\text{Pt}(\text{S}_2\text{CO}^i\text{Pr})_2]$  with 1,4-dibromotetrafluorobenzene; B –  $[\text{Pt}(\text{S}_2\text{COEt})_2]$  with 1,4-diiodotetrafluorobenzene; C –  $[\text{Pt}(\text{S}_2\text{COEt})_2]$  with 1,1'-diiodoperfluorobiphenyl.

Upon analysis of noncovalent interactions in the XRD structures of the co-crystals, we identified Br/I $\cdots$ S XBs between halogen atoms of perfluoroarenes and sulfur centers of dithiocarbonate ligands. Moreover, in the adduct of  $[\text{Pt}(\text{S}_2\text{COEt})_2]$  with 1,1'-diiodoperfluorobiphenyl (Fig. 1C), we recognized bifurcated  $\mu_2$ -I $\cdots$ (O,S) XB involving simultaneously S and O atoms acting as nucleophiles. Supramolecular assembly in the co-crystals is represented by 1D-chains and 2D-layers comprising of heterotetrameric clusters held by XBs.

#### References

- [1] Zelenkov L.E., Eliseeva A.A. Baykov S.V., Suslonov V.V., Galmés B., Frontera A., Kukushkin V. Yu., Ivanov D.M., Bokach N.A. *Inorg. Chem. Front.* **2021**, *8*, 2505–2517
- [2] Zelenkov L.E., Ivanov D.M., Sadykov E.K., Bokach N.A., Galmés B., Frontera A., Kukushkin V. Yu. *Cryst. Growth Des.* **2020**, *20*, 6956–6965

Acknowledgements. This work was supported by the Council for Grants of the President of Russian Federation (project MK-1614.2021.1.3) and the Russian Foundation for Basic Research (project 20-03-00073).

# DESIGN OF CYCLOMETALLATED IRIDIUM(III) COMPLEXES TO PRODUCE METALLOLIGANDS

*Sumovsky D.S., Abramova E.O.*

Saint Petersburg State University, Saint Petersburg, Russia

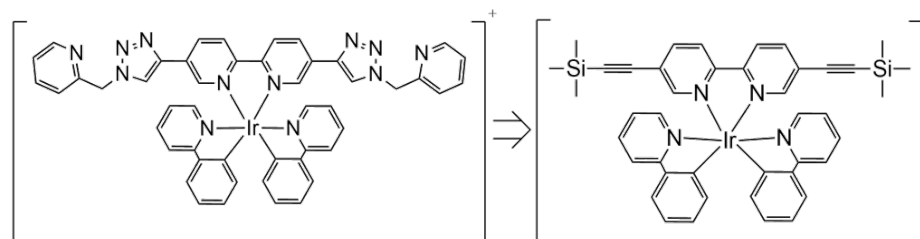
Student

[st087307@student.spbu.ru](mailto:st087307@student.spbu.ru)

Metalloligands (complexes decorated an additional donor site(s)) can be used as the building blocks for the assembly of high-organized heterometallic complexes, including cage compounds and coordination polymers [1]. These compounds have free coordination functions on the periphery of the ligand environment, which allow the addition of the target heterometal. This process requires using of polytopic ligands or post-synthetic modification of the coordination environment of the complex.

Cyclometallated iridium(III) complexes are very attractive for this role because of their advantages, e.g., ease of synthesis, chemical, thermal and photochemical stability.

As part of this concept, a synthetic strategy was developed to functionalize the periphery of the ligand environment by adapting the click-reaction [2] for controlled post-synthetic modification of the cyclometallated iridium(III) complex. All compounds obtained were characterized by NMR spectroscopy, ESI mass spectrometry, and IR spectroscopy.



**Figure 1.** Retrosynthesis of the metalloligand - cyclometallated iridium(III) complex

## References

- [1] Srivastava, S., Gupta, R., *CrystEngComm*, **2016**, 18(48), 9185–9208
- [2] Kolb, H. C., Sharpless, K. B., *Drug Discov. Today* **2003**, 8(24), 1128–1137

Acknowledgements. The authors greatly appreciate financial support from the Russian Science Foundation, grant 21-13-00052. The work was carried out using equipment of Centres for Magnetic Resonance, for Chemical Analysis and Materials Research (Research Park of St.Petersburg State University).

# THREE-COMPONENT NaF-NaVO<sub>3</sub>-Na<sub>2</sub>SO<sub>4</sub> SYSTEM

*Syulyukina D.S., Gubanova T.V.*

Samara State Technical University Samara, Russia

Student

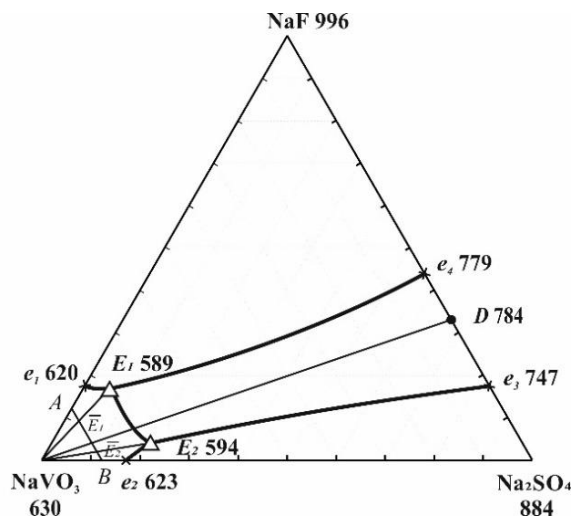
[suylukinadarya@gmail.com](mailto:suylukinadarya@gmail.com)

Ionic melts are in demand in various technologies – for the creation of multifunctional materials - as electrolytes of chemical current sources (HIT), working bodies of thermal accumulators, media for conducting chemical reactions, etc. Having a wide temperature range in the liquid state, their use allows for technological, chemical and electrochemical processes that are impossible for other solvents.

A three-component system of fluoride, metavanadate, and sodium sulfate was selected as the object of study. The facing elements of the three-component system are the eutectic two-component systems NaF-NaVO<sub>3</sub> and NaVO<sub>3</sub>-Na<sub>2</sub>SO<sub>4</sub>. In the NaF-Na<sub>2</sub>SO<sub>4</sub> system, the formation of a congruent melting type compound Na<sub>3</sub>FSO<sub>4</sub> was observed. All two-component systems were investigated [1].

The studies were carried out by the method of differential thermal analysis (DTA) on the DTA unit in the standard version. The initial reagents were previously dehydrated. All compositions are expressed in eq. %, temperature in °C.

The planning of the experiment in the system was carried out in accordance with the rules of the projection-thermographic method (fig. 1).



**Figure 1.** Triangle of compositions of a three-component system NaF-NaVO<sub>3</sub>-Na<sub>2</sub>SO<sub>4</sub>

In the three-component system, a polythermal section AB was selected, the study of which determined the projections of the triple eutectic points E<sub>1</sub> and E<sub>2</sub>, respectively, on the section AB and established the melting temperatures - 589 °C (E<sub>1</sub>) and 594 °C (E<sub>2</sub>).

The compositions and melting temperatures of the eutectics in the triple system were determined by studying the sections that exit from the top of the metavanadate and pass through the projections of eutectics E<sub>1</sub> and E<sub>2</sub>.

The composition can be used as a working fluid of heat accumulators.

## References

[1] Posypaiko V.I., Alekseeva E.A. Diagrams of the fusibility of salt systems. Part III. Double systems with a common cation. Moscow: Metallurgiya, **1979**. 204 p.

# CYCLOMETALATED IRIIDIUM (III) COMPLEXES WITH STERICALLY HINDERED LIGANDS – STRUCTURAL AND PHOTOPHYSICAL INVESTIGATIONS

*Tatarin S.V.*<sup>1,2</sup>, *Bezzubov S.I.*<sup>1</sup>

<sup>1</sup>Kurnakov Institute of General and Inorganic Chemistry RAS, Moscow, Russia

<sup>2</sup>Lomonosov Moscow State University, Moscow, Russia

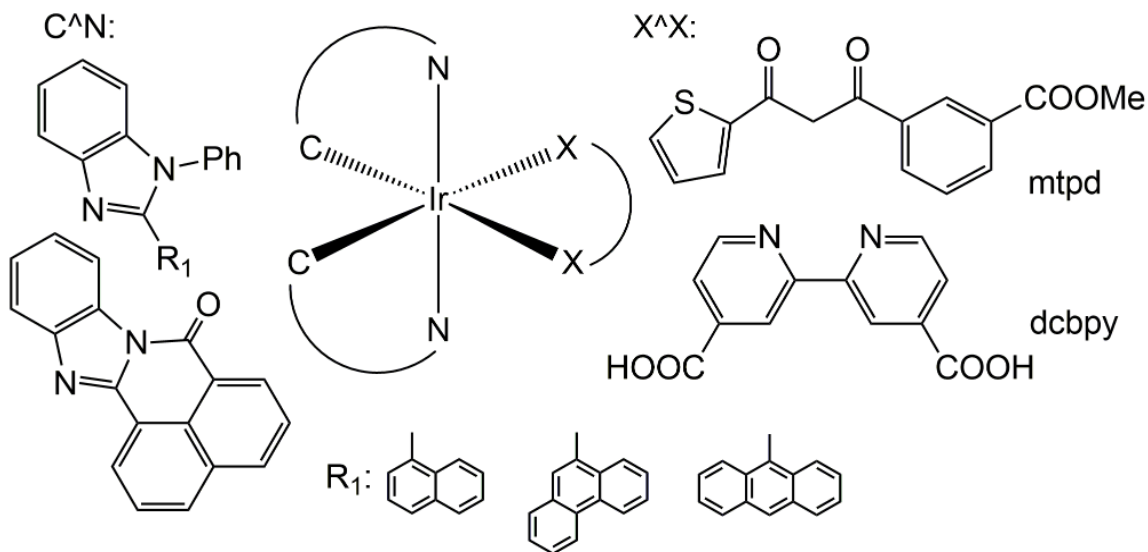
Student

[tatarin.sergei@yandex.ru](mailto:tatarin.sergei@yandex.ru)

Cyclometalated iridium(III) complexes can be utilized as more stable analogs of ruthenium(II) dyes in dye-sensitized solar cells (DSSC). Still, poor light absorption of iridium(III) photosensitizers prevent their widespread application in solar panels.

The extension of the conjugated  $\pi$ -system of ligands is usually considered to be an effective tool for improving light-harvesting and emission properties of iridium(III) complexes. However, use of sterically hindered 2-aryl-N-phenylphenanthro[9,10-d]imidazoles as cyclometalated ligands results in significant distortions of the iridium(III) octahedron greatly reducing the stability of the target compounds without significant increase in their absorption[1]. Based on this study, we have assumed that benzimidazole ligands bearing the aryl unit with the extended  $\pi$ -system should be used.

In this work, a number of new cyclometalated ligands with different number of fused rings in the aryl fragment of N-phenyl-benzimidazoles and corresponding heteroleptic iridium(III) complexes were synthesized. A thorough structural study of the compounds along with the study of their optical and electrochemical properties revealed the limits in which the conjugated  $\pi$ -system can be varied without any negative effect on light-harvesting properties of the complexes. Moreover, the results allowed us to modulate the geometry of cyclometalated complexes (five- or six-membered metallacycles, various degree of distortions of the iridium octahedron) by changing the size of the conjugated  $\pi$ -system of ligands. Finally, we succeeded in isolation of a *mono*-cyclometalated iridium(III) complex with unprecedented square-pyramidal geometry.



**Figure 1.** The complexes studied in this work

## References

[1] Tatarin S.V., Kalle P., Taydakov I.V., Varaksina E.A., Korshunov V.V. and Bezzubov S.I. *Dalton Trans.* **2021**, 50, 6889-6900

# VOLATILE Pd(II) COMPLEXES WITH (O,N,N,O)-CHELATING LIGANDS AND THEIR BIMETALLIC DERIVATIVES

*Teterina A.A.*<sup>1,2</sup>, *Vikulova E.S.*<sup>2</sup>, *Sukhikh A.S.*<sup>2</sup>

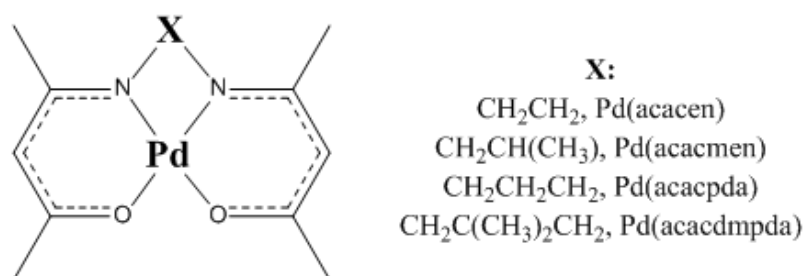
<sup>1</sup>Novosibirsk State University, Novosibirsk, Russia

<sup>2</sup>Nikolaev Institute of Inorganic Chemistry, Novosibirsk, Russia  
Student

[a.teterina@ngsu.ru](mailto:a.teterina@ngsu.ru)

Nowadays Pd-containing bimetallic films and nanoparticles are widely used in various fields including catalysis, sensors, and gas separation membranes. The promising method of obtaining such nano-materials is Metal-Organic Chemical Vapour Deposition (MOCVD). Synchronous deposition from different volatile precursors is a complicated process requiring significant efforts to achieve the target stoichiometry and structure (alloyed/core-shell, etc.) of the bimetallics. Thus, it is of interest to develop volatile bimetallic precursors. However, only a few Pd-containing precursors have been presented [1] and they based on weak intermolecular interactions.

Pd(II) complexes with (O,N,N,O)-chelating ligands of diketoiminate type (Fig.1) are suitable building-blocks for volatile bimetallic molecular precursors due to the presence of oxygen atoms in *cis*-position capable for additional coordination. Previously, the palladium complexes containing propylenediimine bridge were studied [2]. The present work develops this class of Pd precursors and dedicated to an ethylenediimine-bridge complex, Pd(acacen), and its novel derivative containing methyl group in a diimine bridge, Pd(acacmen).



**Figure 1.** Structures of complexes.

Several synthetic methods have been tested to produce complexes in high yield. Both complexes were characterized using elemental analysis, IR- and NMR-spectroscopy, their structures were determined by single-crystal XRD. The tendency to form polymorphic modifications was revealed for both complexes. Namely, three polymorphs were found: space groups *Pna2<sub>1</sub>*, *P2<sub>1</sub>/c*, *P2<sub>1</sub>/n* for Pd(acacen) and space groups *Pna2<sub>1</sub>*, *P-1*, *P2<sub>1</sub>/c* for Pd(acacmen). Pd(acacen) also formed solvates with CHCl<sub>3</sub> and C<sub>6</sub>H<sub>6</sub>. Orthorhombic polymorphs are isostructural to other M(acacen) complexes (M = Cu, Ni). The conditions of isolation of single-phase orthorhombic samples were founded and proved using powder XRD. Thermal properties of both complexes in condensed phase were investigated by thermogravimetry (TGA). The temperature dependences of saturated vapor pressure were measured by the flow method and the thermodynamic parameters of sublimation processes were calculated. It has been shown, that grafting of methyl group in the ethylenediamine bridge lead to increase of saturated vapor pressure of half order of magnitude.

Complex I was successfully applied to obtain bimetallic molecular precursors via a complexation with transition metal hexafluoroacetylacetonates (M = Cu, Co, Ni). According single-crystal XRD, new bimetallic complexes [Pd(acacen)M(hfac)<sub>2</sub>] had similar structures (space group *C2/c*) differing in the parameters of M coordination environment. Specifically, M-O<sub>hfac</sub> bond lengths for copper complex differed by 0,178 Å whereas for cobalt and nickel ones these distances were near equal. The bridged bond lengths M-O<sub>acacen</sub> decrease in the row M = Cu > Co > Ni. Thermal behavior of all complexes was investigated by TGA: [Pd(acacen)Cu(hfac)<sub>2</sub>] decomposed under these conditions whereas Co, Ni-containing analogs partially vaporized. The intermediate and final decomposition products of the Pd-Cu complex were studied carefully. Vacuum sublimation test showed Pd-Co complex to be suitable for MOCVD application.

## References

- [1] Krisyuk, V. V., Turgambaeva, A. E., et al. *Vacuum*. **2019**, 166, 248.  
[2] Vikulova E.S., Cherkasov S.A., et al. *J. Therm. Anal. Calorim.* **2019**, 135, 2573.

# POTENTIOMETRIC STUDY OF GALLIUM CONTAINING CHLORIDE MELTS

*Tokarev O.V.<sup>1</sup>, Volkovich V.A.<sup>1</sup>*

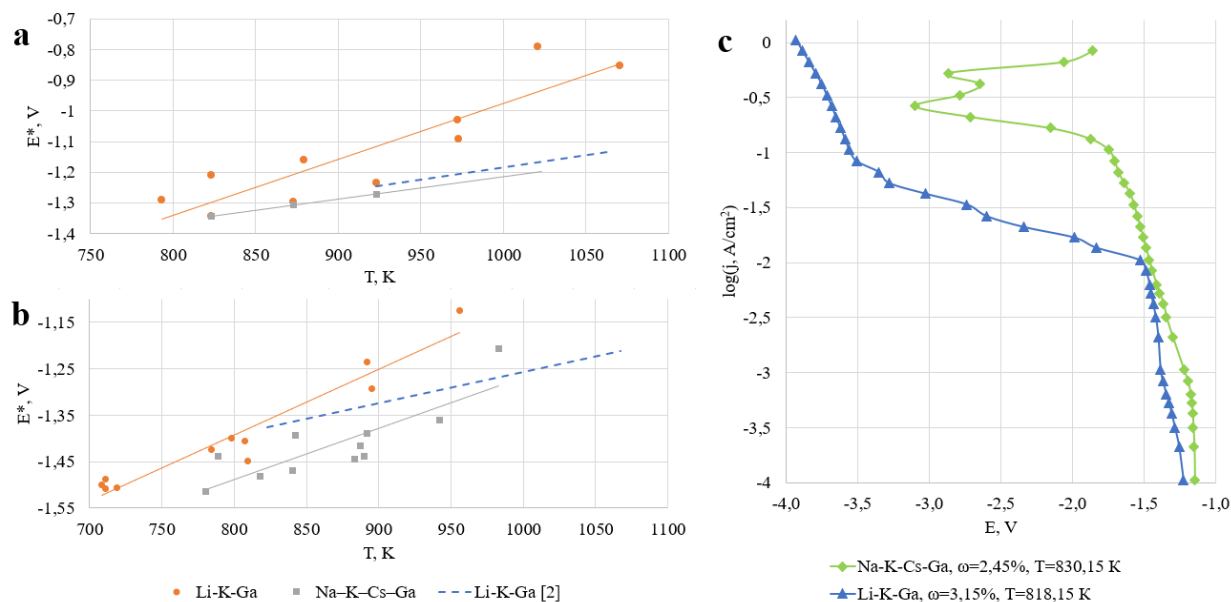
<sup>1</sup>Ural Federal University, Yekaterinburg, Russia

Student

[olegtokarev1999@gmail.com](mailto:olegtokarev1999@gmail.com)

At present gallium based low melting alloys are considered as prospective working media for separating uranium and rare earth fission products in pyrochemical reprocessing of spent nuclear fuels using partitioning in “molten salt – liquid metal (alloy)” systems [1]. Comprehensive information concerning electrochemical properties and behaviour of the elements present in the system is required for developing a feasible and reliable process. The electrochemistry of gallium in molten salts was very little studied and the aim of the present work was investigating electrochemical behaviour of gallium in chloride melts based on 3LiCl–2KCl and 6NaCl–9KCl–5CsCl eutectic mixtures.

The experiments were performed in LiCl–KCl–GaCl<sub>3</sub> melts at 400–800 °C and NaCl–KCl–CsCl–GaCl<sub>3</sub> melts at 500–750 °C using chronopotentiometry at zero current, cyclic voltammetry, cathodic and anodic polarization. Analysis of the experimental results showed that reduction of Ga<sup>3+</sup> ions to Ga is a two-stage process going through Ga<sup>+</sup> ions formation. Temperature dependencies of formal standard electrode potentials of Ga<sup>3+</sup>/Ga and Ga<sup>+</sup>/Ga in 3LiCl–2KCl and 6NaCl–9KCl–5CsCl based melts were obtained (Fig. 1(a) and (b)). Examples of the cathodic polarization curves for tungsten electrodes in gallium containing melts are shown in Fig. 1(c).



**Figure 1.** Temperature dependencies of gallium formal standard potential for n=1 (a) and n=3 (b), and cathodic polarization curves obtained on tungsten electrode (c) for 3LiCl–2KCl and 6NaCl–9KCl–5CsCl based melts. All potentials are given vs. Cl<sup>-</sup>/Cl<sub>2</sub> reference electrode

It was also found that molybdenum cannot be used as the electrode material in studying gallium containing chloride melts. Contact of molybdenum with the molten salt affected the values of the electrode potential of gallium measured in such experiments.

## References

- [1] V. A. Volkovich, D. S. Maltsev, E. V. Raguzina, A. S. Dedyukhin, A. V. Shchetinskiy, L. F. Yamshchikov, A. V. Chukin, *J. Alloys Comp.*, **2019**, *787*, 367–378.
- [2] P. M. Usov, E. A. Saltykova, *Rasplavy*, **1987**, *1*, 3, 110–113.

# INFLUENCE OF ALKALINE-EARTH OXIDES (MGO, SRO, BAO) ON PHYSICAL-CHEMICAL CHARACTERISTICS CALCIUM BOROSILICATE GLASS

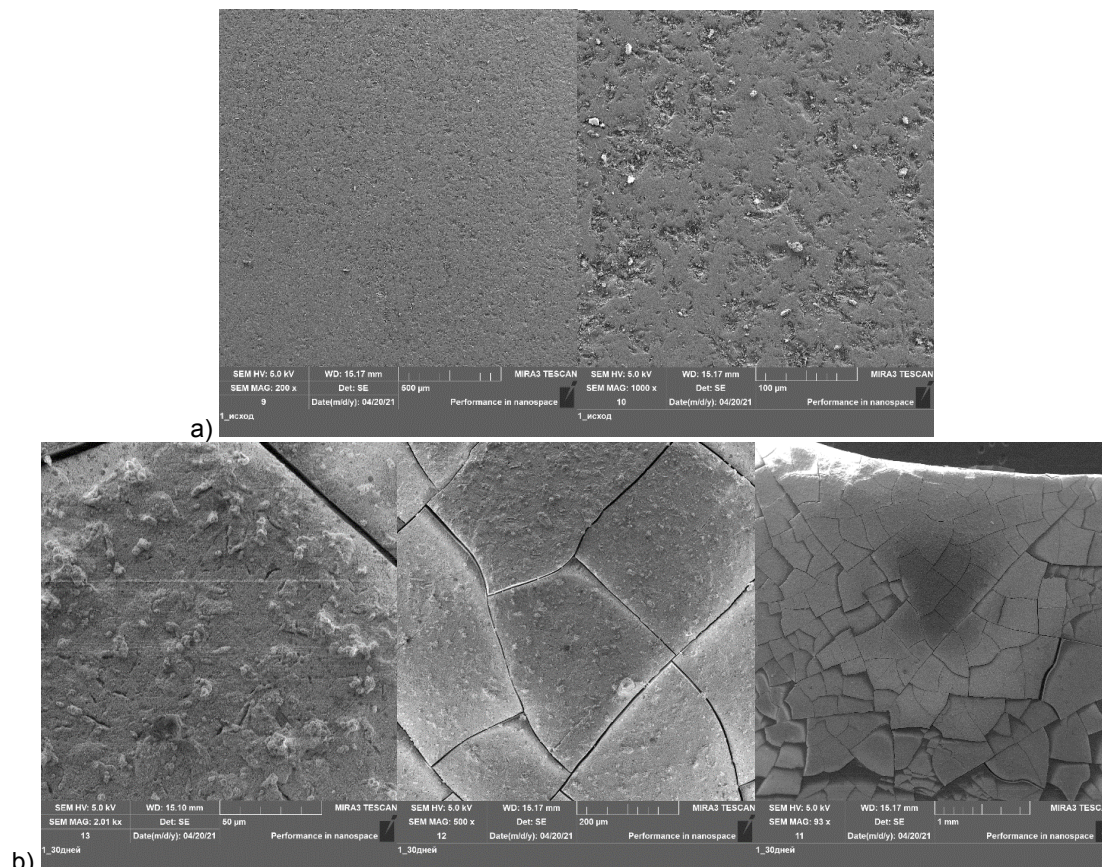
*Tolmacheva N.N.<sup>1</sup>, Tyurnina N.G.<sup>2</sup>, Tyurnina Z.G.<sup>2</sup>*

<sup>1</sup> Saint-Petersburg State Institute of Technology, Saint-Petersburg, Russia

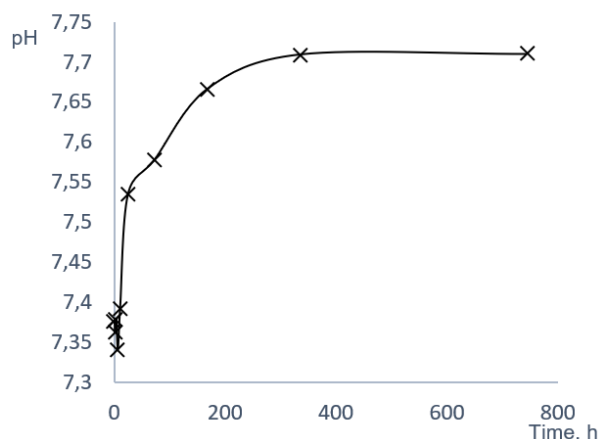
<sup>2</sup> Institute of Silicate Chemistry, Russian Academy of Sciences (ISC RAS), Saint-Petersburg, Russia  
Student

[nellitolmacheva78@gmail.com](mailto:nellitolmacheva78@gmail.com)

The five bioactive glasses containing different components were synthesized: 1 - 14%Na<sub>2</sub>O–45%SiO<sub>2</sub>–30%CaO–5%B<sub>2</sub>O<sub>3</sub>–2%P<sub>2</sub>O<sub>5</sub>–4%CaF<sub>2</sub>; 2 - 14% K<sub>2</sub>O–45%SiO<sub>2</sub>–30%CaO–5%B<sub>2</sub>O<sub>3</sub>–2%P<sub>2</sub>O<sub>5</sub>–4%CaF<sub>2</sub>; 3 - 14%K<sub>2</sub>O–45%SiO<sub>2</sub>–20%CaO–5%B<sub>2</sub>O<sub>3</sub>–2%P<sub>2</sub>O<sub>5</sub>–4%CaF<sub>2</sub>–10% MgO; 4 - 14%K<sub>2</sub>O–45%SiO<sub>2</sub>–20%CaO–5%B<sub>2</sub>O<sub>3</sub>–2%P<sub>2</sub>O<sub>5</sub>–4%CaF<sub>2</sub>–10% SrO; 5 - 14%K<sub>2</sub>O–45%SiO<sub>2</sub>–20%CaO–5%B<sub>2</sub>O<sub>3</sub>–2%P<sub>2</sub>O<sub>5</sub>–4%CaF<sub>2</sub>–10%BaO, and changing of their properties were analyzed.



**Figure 1.** SEM micrographs of Compound #1 (a) before and (b) after immersed in SBF for 30 days.



Compounds which contain MgO, SrO and BaO have the higher value of Vickers microhardness, for example: Com. #1 – 574 MPa; Com. #2 – 548 MPa; Com. #3 – 624 MPa; Com. #4 – 604 MPa; Com. #5 – 663 MPa. All compounds exhibit biologically active properties in SBF solution during the first 7 days, forming a layer of hydroxyapatite on the surface.

**Figure 2.** Variation of pH of SBF solution measured on various time intervals for Compound #1 during the immersion.



# DYCYANOPHENOXY-SUBSTITUTED MAGNESIUM PHTHALOCYANINATES AND THEIR METAL-FREE ANALOGS: SYNTHESIS, PHOTOCHEMICAL AND PHOTOPHYSICAL PROPERTIES

*Tonkova S.S., Erzunov D.A., Belikova A.A., Vashurin A.S.*

Ivanovo State University of Chemistry and Technology, Ivanovo, Sheremetevsky Avenue, 7

Student

[Tonkova2000@mail.ru](mailto:Tonkova2000@mail.ru)

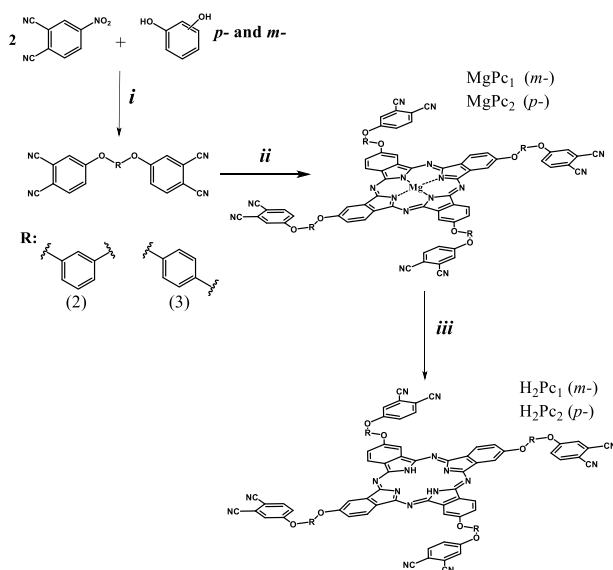
Phthalocyanines have a macrocyclic aromatic system conjugated by 18  $\pi$ -electrons. Wherefore, this class of compounds has valuable optical, thermal and electrochemical properties. Phthalocyanines have been used great numbers of technological and medical applications such as catalyst, light emitting diodes, biological imaging, gas sensor, dyes and pigments. Also this compounds are suitable photosensitizers for PDT applications with their high absorption in the visible region, absence of toxicity in the dark, high stability in solutions, high singlet oxygen yield and high selectivity for high-quality tissues. In addition, the phthalocyanine ring can exhibit redox properties due to high  $\pi$ -electron delocalization.

In this work, magnesium metal phthalocyaninates and their metal-free analogues with cyanophenoxy-peripheral substituents were synthesized. Magnesium complexes were obtained by template fusion of magnesium acetate tetrahydrate with the corresponding nitrile. Compounds were purified by column chromatography on silica gel M60 with chloroform as eluent.

Metal-free phthalocyaninates were obtained by boiling metal complexes in hydrochloric acid. The complexes were washed with water until neutral (Scheme 1).

For the obtained compounds, the spectral and fluorescent properties, aggregation behavior were studied, the lifetime and quantum yields of fluorescence were determined, and the Stern-Volmer constants were calculated in various organic compounds.

The compounds showed good solubility in most organic solvents such as chloroform, acetone, DMF due to the introduction of suitable substituents, which made it possible to study their spectral and fluorescent properties in these media. It turned out that ligands aggregate in acetone and DMF even at relatively low concentrations, while the introduction of magnesium into the coordination center corrects this problem. Metal complexes showed higher values of extinction coefficients and quantum yields of fluorescence in comparison with ligands and unsubstituted zinc phthalocyanine as a standard. It was shown the quenching of fluorescence for the studied compounds by the addition of benzoquinone proceeds, in the general case, faster than for unsubstituted ZnPc, and the constants of this process were determined; however, the opposite tendency is observed in the DMF medium.



**Scheme 1.** Synthetic pathway for substituted phthalocyaninates and ligands.

(i):  $\text{K}_2\text{CO}_3$ , DMF,  $153^\circ\text{C}$ , 8 h; (ii):  $\text{MgAc}_2$ ,  $190^\circ\text{C}$ , 30 min; (iii): HCl, refluxing for 20 min.

Acknowledgements. The work was supported by Russian Science Foundation grant №17-73-20017.

*Toshev O.U.<sup>1</sup>, Stegalin G.L.<sup>2</sup>, Safronova T.V.<sup>1,2</sup>, Shatalova T.B.<sup>1,2</sup>, Lukina U.S.<sup>3</sup>, Malyutin K.V.<sup>4</sup>*

<sup>1</sup>Faculty of Materials Science, Moscow State University, Moscow, Russia

<sup>2</sup>Department of Chemistry, Moscow State University, Moscow, Russia

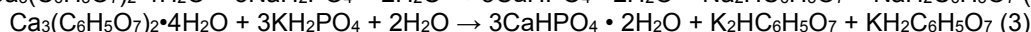
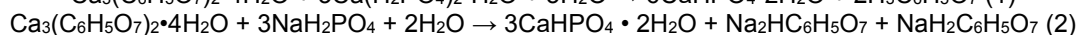
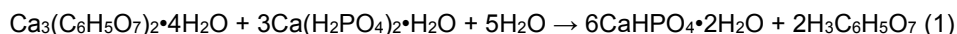
<sup>3</sup>D. Mendeleev University of Chemical Technology of Russia, Moscow, Russia

<sup>4</sup>Moscow Polytechnic University, Moscow, Russia

PhD student

[otabektoshev0995@gmail.com](mailto:otabektoshev0995@gmail.com)

This work is aimed at creating biocompatible ceramic materials in CaO-P<sub>2</sub>O<sub>5</sub>, CaO-P<sub>2</sub>O<sub>5</sub>-Na<sub>2</sub>O and CaO-P<sub>2</sub>O<sub>5</sub>-K<sub>2</sub>O systems, by heat treatment of green powder products (cement stone) formed from highly loaded hardening suspensions. The following reactions were used to calculate the composition of starting powder mixtures:



Calcium citrate tetrahydrate (Ca<sub>3</sub>(C<sub>6</sub>H<sub>5</sub>O<sub>7</sub>)<sub>2</sub>·4H<sub>2</sub>O) and calcium dihydrogen phosphate monohydrate (Ca(H<sub>2</sub>PO<sub>4</sub>)<sub>2</sub>·H<sub>2</sub>O), sodium dihydrogen phosphate (NaH<sub>2</sub>PO<sub>4</sub>) and potassium dihydrogen phosphate (KH<sub>2</sub>PO<sub>4</sub>) powders were used as components of the starting powder mixtures with the molar ratio corresponding to the reaction equations (1-3). Powder mixtures were homogenized in a planetary mill in an acetone medium for 15 minutes. Then the resulting powder mixtures were mixed with water at a water-solid ratio (w/s) = 0.5 by weight. A latex form was filled with the resulting paste and prepared samples were left for hardening and drying at the air for a week.

The phase composition of cement stone samples based on Ca<sub>3</sub>(C<sub>6</sub>H<sub>5</sub>O<sub>7</sub>)<sub>2</sub>·4H<sub>2</sub>O and Ca(H<sub>2</sub>PO<sub>4</sub>)<sub>2</sub>·H<sub>2</sub>O, Ca<sub>3</sub>(C<sub>6</sub>H<sub>5</sub>O<sub>7</sub>)<sub>2</sub>·4H<sub>2</sub>O and NaH<sub>2</sub>PO<sub>4</sub>, Ca<sub>3</sub>(C<sub>6</sub>H<sub>5</sub>O<sub>7</sub>)<sub>2</sub>·4H<sub>2</sub>O and KH<sub>2</sub>PO<sub>4</sub> was represented by brushite (CaHPO<sub>4</sub>·2H<sub>2</sub>O), monetite (CaHPO<sub>4</sub>) and unreacted Ca<sub>3</sub>(C<sub>6</sub>H<sub>5</sub>O<sub>7</sub>)<sub>2</sub>·4H<sub>2</sub>O and Ca(H<sub>2</sub>PO<sub>4</sub>)<sub>2</sub>·H<sub>2</sub>O, NaH<sub>2</sub>PO<sub>4</sub>, KH<sub>2</sub>PO<sub>4</sub> respectively. The presence of unreacted salts is associated with the incompleteness of the reactions 1-3 during the process of chemical bonding.

Cement stone samples with phase composition including monetite, sodium citrate, potassium citrate, citric acid and non-reacted components, were annealed in the furnace in the temperature range of 500-1000°C with an exposure of 2 hours for obtaining ceramics. During heat treatment, the components in the cement stone are subjected to thermal destruction, and the resulting components interact with each other. The phase composition of the ceramic materials was investigated using X-ray diffraction data analysis.

After annealing of cement stone based on Ca<sub>3</sub>(C<sub>6</sub>H<sub>5</sub>O<sub>7</sub>)<sub>2</sub>·4H<sub>2</sub>O and Ca(H<sub>2</sub>PO<sub>4</sub>)<sub>2</sub>·H<sub>2</sub>O at 500°C phase composition of the ceramic materials was represented by γ-Ca<sub>2</sub>P<sub>2</sub>O<sub>7</sub> and γ-Ca(PO<sub>3</sub>)<sub>2</sub>. In the temperature range of 700-900°C γ-Ca(PO<sub>3</sub>)<sub>2</sub> and γ-Ca<sub>2</sub>P<sub>2</sub>O<sub>7</sub> phases passed into a higher-temperature modifications (β-Ca(PO<sub>3</sub>)<sub>2</sub> and β-Ca<sub>2</sub>P<sub>2</sub>O<sub>7</sub>). And after annealing at 1000°C the phase composition of ceramics was presented only with β-Ca<sub>2</sub>P<sub>2</sub>O<sub>7</sub>.

Heat treatment of cement stone based on Ca<sub>3</sub>(C<sub>6</sub>H<sub>5</sub>O<sub>7</sub>)<sub>2</sub>·4H<sub>2</sub>O and NaH<sub>2</sub>PO<sub>4</sub> 500°C resulted in the formation of a phase composition that included the phases β-CaNaPO<sub>4</sub> and Ca<sub>10</sub>(PO<sub>4</sub>)<sub>6</sub>(OH)<sub>2</sub>. At 700°C, in addition to β-CaNaPO<sub>4</sub> and Ca<sub>10</sub>(PO<sub>4</sub>)<sub>6</sub>(OH)<sub>2</sub>, the phases of double calcium – sodium pyrophosphate Na<sub>2</sub>CaP<sub>2</sub>O<sub>7</sub> and tricalcium phosphate β-Ca<sub>3</sub>(PO<sub>4</sub>)<sub>2</sub> were formed. After firing at 900 °C, only the β-CaNaPO<sub>4</sub> phase was detected in the ceramic according to X-ray diffraction data.

After firing of cement stone based on Ca<sub>3</sub>(C<sub>6</sub>H<sub>5</sub>O<sub>7</sub>)<sub>2</sub>·4H<sub>2</sub>O and KH<sub>2</sub>PO<sub>4</sub> at 500°C the phase composition of the samples was represented by the phases β-CaKPO<sub>4</sub>, Ca<sub>10</sub>(PO<sub>4</sub>)<sub>6</sub>(OH)<sub>2</sub> and β-Ca<sub>3</sub>(PO<sub>4</sub>)<sub>2</sub>. After firing in the temperature range of 700-900°C, CaKPO<sub>4</sub> passes into a higher-temperature modification-α-CaKPO<sub>4</sub>, and the phases of double calcium – potassium pyrophosphate K<sub>2</sub>CaP<sub>2</sub>O<sub>7</sub> and potassium-substituted tricalcium phosphate Ca<sub>10</sub>K(PO<sub>4</sub>)<sub>7</sub> were also observed. After firing at 900°C, only the α -CaKPO<sub>4</sub> phase was detected in the ceramic according to X-ray diffraction data.

The resulting material based on β-Ca<sub>2</sub>P<sub>2</sub>O<sub>7</sub>, β-CaNaPO<sub>4</sub>, and β-CaKPO<sub>4</sub> which has the ability to slowly dissolve, can be used in regenerative medicine for the treatment of bone defects.

Acknowledgements. This work was supported by Russian Foundation for Basic Research (project No 18-29-11079).

# CYTOPROTECTIVE PROPERTIES OF LANTHANUM CARBOXYLATES CONTAINING FRAGMENT OF 2,6-DI-*TERT*-BUTYLPHENOL

*Trusova A.B.*<sup>1</sup>, *Nikitin E.A.*<sup>1</sup>, *Latipov E.V.*<sup>1,2</sup>

<sup>1</sup>Moscow State University, Moscow, Russia

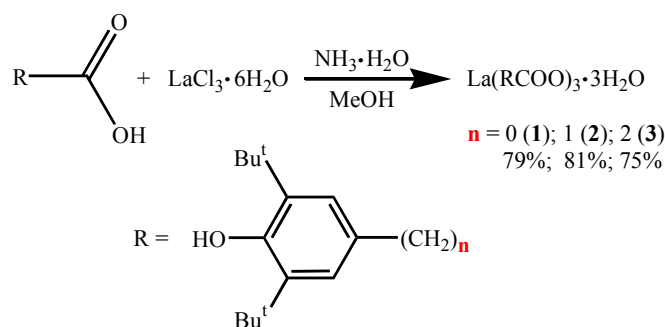
<sup>2</sup>Institute of Nanotechnology of Microelectronics of the Russian Academy of Sciences, Moscow, Russia  
Student

[alla.trusova.fnm@gmail.com](mailto:alla.trusova.fnm@gmail.com)

Oxidative stress is an imbalance between the action of antioxidants and pro-oxidants in favor of the latter. This pathological condition participates in a development of many diseases, including various types of cancer. The search for antioxidants preventing oxidative stress is of a great importance. 2,6-Di-alkylphenols are widely used as antioxidants, radical scavengers and biomimetics of  $\alpha$ -tocopherol [1].

On the other hand, rare earth elements play an important role in proper functioning of any biological system, e.g. lanthanoid elements are known to act as calcium analogs in the biological systems. Besides, lanthanides possess various medicinal applications, and can be applied as antitumor agents, kidney dialysis medicines and used in surgical equipment [2]. Medicines with lanthanum ("Eplan") are considered to have regenerating, bactericidal, wound healing properties. This allows us to suggest lanthanum as a potential component of physiologically active substances.

Presented work is aimed at the synthesis and evaluation of antioxidant activity of lanthanum complex compounds containing the antioxidant fragment of 2,6-di-*tert*-butylphenol. The resulting series of La (**1-3**) carboxylates was characterized by thermogravimetry, elemental analysis, IR and NMR spectroscopy.



**Figure 1.** Reaction.

The antioxidant properties of complexes **1-3** have been studied in model reactions. The activity of compounds as radical scavengers was evaluated in reactions with stable radical 2,2-diphenyl-1-picrylhydrazyl (DPPH) and with  $\text{O}_2^{\cdot-}$ . The affinity of the compounds to one-electron transition was measured in CUPRAC-test. Additionally, inhibitory effect of complexes on soy bean lipoxygenase (LOX 1-B) was studied. It was shown that synthesized carboxylates possess antioxidant properties far superior to the pure ligands. The results open up the perspectives for future application of these compounds as hybrid cytoprotectors.

## References

- [1] Nikitin E.A., Shpakovsky D.B. et al. *Pharm Pharmacol Int J.* **2020**, *8*(3), 122-134.  
[2] Antonenko T.A., Shpakovsky D.B. et al. *Inorganica Chimica Acta.* **2017**, *455*, 276-282.

Acknowledgements. This work was supported by Russian Foundation for Basic Research (project No 19-33-90236).

EXPERIMENTAL AND THEORETICAL INVESTIGATIONS OF NEW VOLATILE PALLADIUM COMPLEXES WITH FLUORINATED  $\beta$ -DIKETONES AND  $\beta$ -IMINOKETONES

*Tryakhov D. E.<sup>1,2</sup>, Dorovskikh S. I.<sup>2</sup>*

<sup>1</sup>Novosibirsk State University, Novosibirsk, Russia

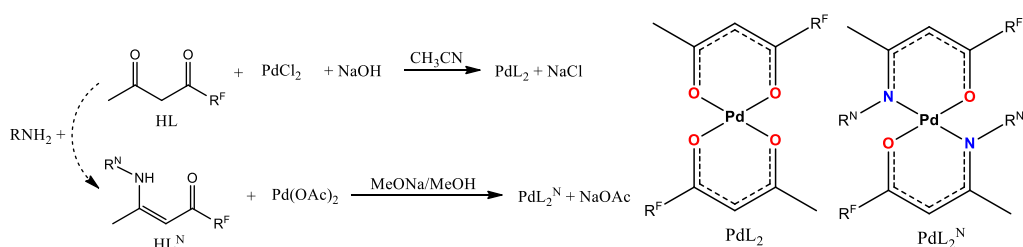
<sup>2</sup>Nikolaev Institute of Inorganic Chemistry, Novosibirsk, Russia

Student

[tryakhovd@gmail.com](mailto:tryakhovd@gmail.com)

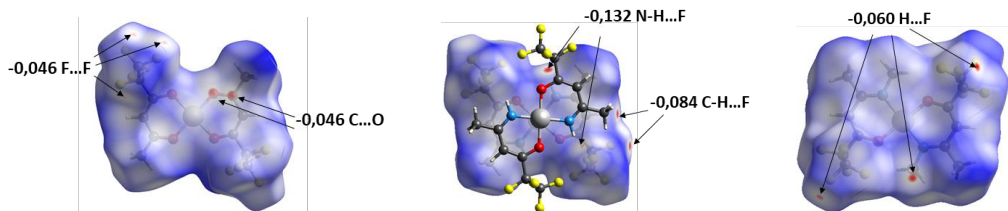
Palladium-based materials are widely used in microelectronics, catalysis, also as active membranes for highly efficient hydrogen purification. Metal Organic Chemical Vapor Deposition (MOCVD) is one of the demanded techniques to fabricate the above materials on the various substrates including 3D ones. Among volatile compound used as initial sources in MOCVD processes a special attention has been paid to Pd  $\beta$ -diketonates and  $\beta$ -iminoketonates those structure and thermal properties changes in a wide range at the variation of ligand substitutes. It is known that a volatility of these complexes increases with ligand fluorosubstitution [1], but the detailed studies in this field have been performed only for limited series of Pd complexes. Here, we focus on experimental and theoretical investigations of series of fluorinated Pd  $\beta$ -diketonate and  $\beta$ -iminoketonete complexes to study in a detail the effect of fluorosubstitution in ligands on structural features and volatility of Pd complexes.

In the framework of the present study, series of new palladium complexes  $[\text{Pd}(\text{L})_2]$ ,  $[\text{Pd}(\text{L}^{\text{N}})_2]$ , (Fig. 1), where,  $\text{R}^{\text{N}} = \text{H}, \text{Me}$  and  $\text{R}^{\text{F}} = \text{C}_2\text{F}_5, \text{C}_3\text{F}_7$  in all possible combinations are synthesized with 70-80% yields. The resulting compounds were purified by vacuum sublimation and characterized by elemental analysis, IR and NMR spectroscopy.



**Figure 1.** Scheme of the synthesis of Pd complexes

The crystal structures of new compounds were firstly studied by X-ray diffraction method and Hirshfeld surface analysis (Fig. 2). In order to study the effect of the structure of ligands on the presence of weak dispersion interactions, the analysis of critical points in the crystals of the complexes and the energy of the crystal lattice was calculated in PBE-D3(BJ)/TZ2P/ZORA level of theory using ADF-BAND program package. The features and differences in the electronic structure of Pd  $\beta$ -iminoketonate and  $\beta$ -diketonate complexes are discussed on the basis of NBO analysis of molecules with optimized geometry in the gas phase.



**Figure 2.** Hirshfeld surfaces of Pd  $\beta$ -diketonate and Pd  $\beta$ -iminoketonates with  $\text{R}^{\text{F}} = \text{C}_2\text{F}_5$  substituents.

From TG-DTA all compounds transfer to the gas phase in one step completely. It was found that the highest volatility observed for  $\beta$ -iminoketonates containing NH group.

### References

[1] N. S. Nikolaeva, N. V. Kuratieva, E. S. Vikulova, P. A. Stabnikov, N. B. Morozova, *Polyhedron*, **2019**, *171*, 455–463

«2+1» TRICARBONYL COMPLEXES OF TECHNETIUM-99 AND RHENIUM  
WITH ETHYL 2-ISOCYANOACETATE

*Tyupina M.Yu.*<sup>1,2</sup>, *Miroslavov A.E.*<sup>1,2</sup>, *Sidorenko G.V.*<sup>2</sup>, *Gurzhiy V.V.*<sup>1</sup>

<sup>1</sup>Saint Petersburg State University, Saint Petersburg, Russia

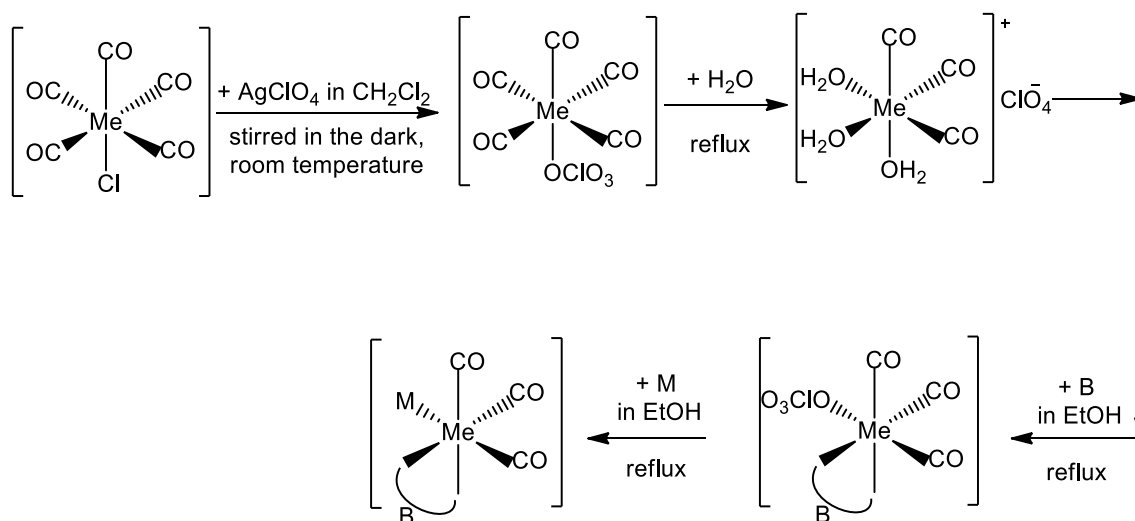
<sup>2</sup>V.G. Khlopin Radium Institute, Saint Petersburg, Russia

PhD Student

[mtupina@mail.ru](mailto:mtupina@mail.ru), [st072285@student.spbu.ru](mailto:st072285@student.spbu.ru)

Previously we showed that the heart uptake of «2+1» tricarbonyl complexes of technetium with 1,10-phenanthroline and 2,2'-bipyridine is comparable to that of MIBI [1]. We also found that isocyanides form strong complexes with technetium(I) [2]. These data suggest that of «2+1» tricarbonyl complexes of technetium with 1,10-phenanthroline and 2,2'-bipyridine can be used to introduce technetium via the isocyanide group into fatty acids.

The aim of this work was to develop a procedure for preparing «2+1» tricarbonyl complexes of technetium-99,99m and rhenium with a combination of the bidentate ligands and ethyl 2-isocyanoacetate. The procedure is presented on the following scheme:



where Me - Tc or Re

Where B - bidentate ligand  
M - monodentate ligand

**Figure 1.** Reaction (scheme).

The complexed we isolated and characterized by SCXRD, IR, UV/Vis and NMR spectroscopy. Their technetium-99m analogs were also obtained and characterized by HPLC. The stability of the «2+1» complexes of technetium was studied.

### References

- [1] B.L. Ellis, N.I. Gorshkov, A.A. Lumpov, A. E. Miroslavov et al. *J. Labelled Comp. Radiopharmaceut.* **2013**, 56, 700  
[2] Miroslavov A.E., Polotskii Yu.S., Gurzhiy V.V., Lumpov A.A., Tyupina M.Yu. et al. *Inorg. Chem.* **2014**, 53, 7861

Acknowledgements. This work was supported by the Russian Foundation for Basic Research (project No 19-33-90040\19).

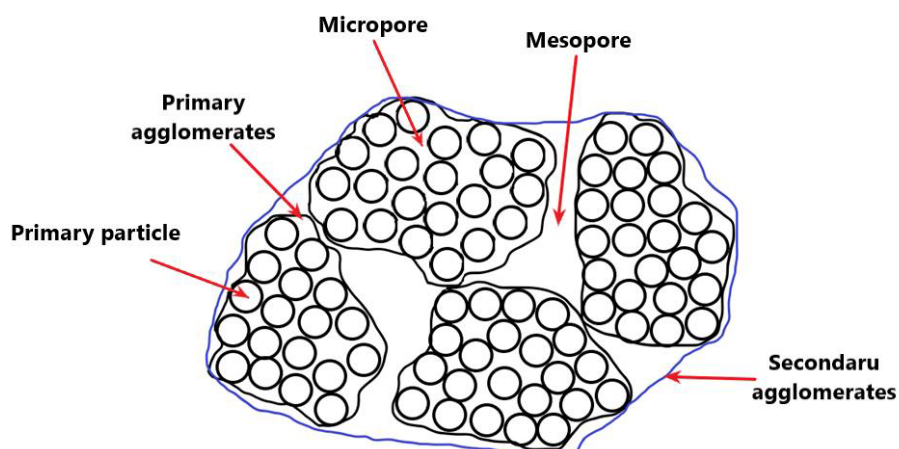
# SYNTHESIS OF MAGNESIUM SILICATE ADSORBENTS WITH DIFFERENT MOLAR RATIO $MgO:SiO_2$ AND RESEARCH OF POROUS STRUCTURE FORMATION MECHANISM

*Uglunts T.V*<sup>1</sup>, *Semencha A.V*<sup>1</sup>, *Klinkov V.A.*<sup>1</sup>

<sup>1</sup> Peter the Great St. Petersburg Polytechnic University (SPbPU), Saint Petersburg, Russia  
Student  
[tuglunts@mail.ru](mailto:tuglunts@mail.ru)

Improving the quality of life and environmental requirements determine the necessity to refine cleaning technologies, separation of industrial waste and contaminants. The purification of non-polar organic liquids from polar pollutants is carried out using adsorption methods. The advanced class of adsorbents are adsorbents based on magnesium silicate. The adsorption capacity of the adsorbent is determined by the value of its specific surface area.

The characteristics of adsorbents are also determined by the chemical composition, porosity and surface morphology. The IUPAC classification includes three types of adsorbents porous size: micropore ( $r < 2$  nm), mesopore ( $2 < r < 50$  nm), macropore ( $r > 50$  nm). When the proportion of micropores (for example, activated carbons) predominates in the sorbent the specific surface area increases, but the rate of adsorption decreases due to the low micropores availability of adsorbate particles. Mesopores and macropores mainly serve as intermediate pores and transport the substance to the micropores [2]. Therefore, to obtain a sorbent with a specific set of properties (for different applications), it is necessary to control the process of porous structure formation.



**Figure 1.** Porous structure formation mechanism of  $xMgO \cdot ySiO_2$  composition

This research is devoted to study the influence of molar ratio  $MgO:SiO_2$ , drying temperature, synthesis mode and sonication on specific surface area and porous parameters. Assumptions about the mechanism of formation of the pore structure of the adsorbent, which is determined by the processes of primary and secondary agglomeration of particles during synthesis and subsequent processing, were made as a result of the study. Mechanism of agglomeration and porous structure formation is schematically shown on fig. 1. Also, the influence of various functional groups on the properties of the adsorbent was studied.

## References

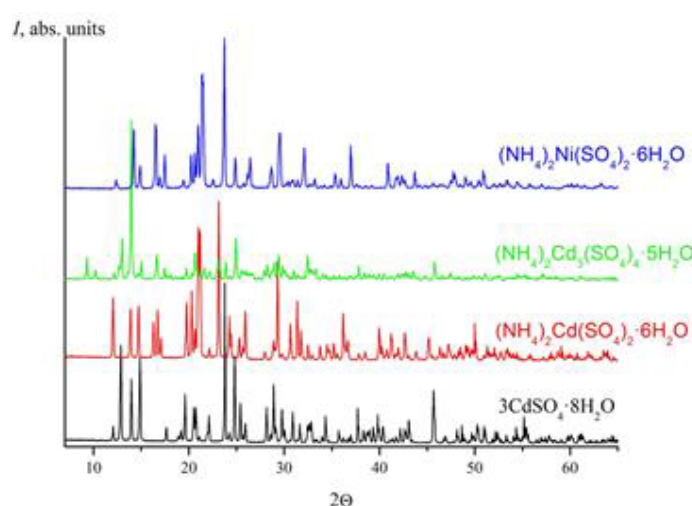
- [1] Dietemann M. et al. *Chem. Eng. J.*, **2013**, 215–216.
- [2] F. A. L. DULLIEN, "Pore Structure," in *Porous Media*, 1992.

Acknowledgements. This work was supported by the FASIE (project № 15651GY/2020). This work was supported by the grant of the President of the Russian Federation for young PhD scientists No. MK-2869.2021.1.2

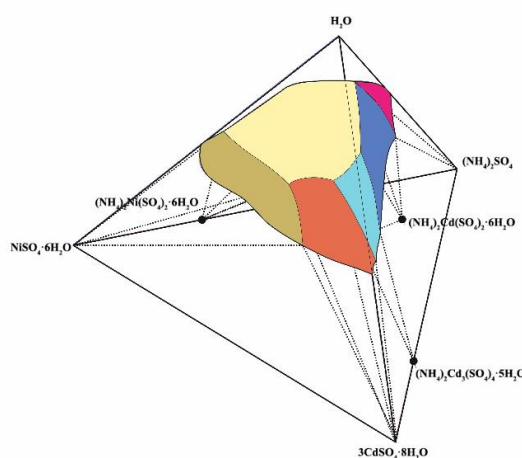
In modern society, there is an acute problem of processing secondary raw materials, including used batteries. Nickel-cadmium batteries are a prime example of this kind of waste. The most common way of their processing is sulfuric acid leaching, after which the separation of the components is carried out by precipitation of Tutton's salts. As part of this study, a four-component solubility system  $\text{NiSO}_4 \cdot 6\text{H}_2\text{O}$  -  $3\text{CdSO}_4 \cdot 8\text{H}_2\text{O}$  -  $(\text{NH}_4)_2\text{SO}_4$  -  $\text{H}_2\text{O}$  was built.

The obtained results made it possible to present a diagram of phase equilibria. By the method of parallel crystallizations has been studied the interactions of the components in the system under isothermal equilibrium conditions at  $30^\circ\text{C}$ . Samples of substances were kept in a WSB-18 thermostat-shaker (Witeg Labortechnik Germany) with a movable cassette holder for vessels and a programmable PID temperature controller.

By XRD analysis has been determined the phase composition of the samples. The samples ground into powder were taken at room temperature on a desktop X-ray diffractometer Rigaku Miniflex 600 (Japan) in a normal atmosphere.



**Fig. 1.** XRD data of confirmed compounds in the system.



**Fig. 2.** View of the four-component system

In this work, phase equilibria in the four-component water-salt system  $3\text{CdSO}_4 \cdot 8\text{H}_2\text{O}$  -  $\text{NiSO}_4 \cdot 6\text{H}_2\text{O}$  -  $(\text{NH}_4)_2\text{SO}_4$  -  $\text{H}_2\text{O}$  have been investigated. At the same time, in the ternary systems forming the investigated four-component system, the formation of double sulfates  $(\text{NH}_4)_2\text{Cd}_3(\text{SO}_4)_4 \cdot 5\text{H}_2\text{O}$  [1],  $(\text{NH}_4)_2\text{Cd}(\text{SO}_4)_2 \cdot 6\text{H}_2\text{O}$  [2] and  $(\text{NH}_4)_2\text{Ni}(\text{SO}_4)_2 \cdot 6\text{H}_2\text{O}$  [3] was confirmed. The crystallization regions of double sulfates  $(\text{NH}_4)_2\text{Cd}_3(\text{SO}_4)_4 \cdot 5\text{H}_2\text{O}$ ,  $(\text{NH}_4)_2\text{Cd}(\text{SO}_4)_2 \cdot 6\text{H}_2\text{O}$ ,  $(\text{NH}_4)_2\text{Ni}(\text{SO}_4)_2 \cdot 6\text{H}_2\text{O}$  are delimited.

#### References

- [1] *D. Swain, T. N. Guru Row* Structure report.  $(\text{NH}_4)_2\text{Cd}_3(\text{SO}_4)_4 \cdot 5\text{H}_2\text{O}$  / Acta Crystallographica -2006 –Section E –p. 226-227
- [2] *Montgomery H., Lingafelte E. C.* Acta Cryst. **1966**, 20, 728-730.
- [3] *N.W.Grimes, H.F.Kay, W.Webb* Acta Crystallographica, **1963**, 16, 823-829.

Acknowledgements. Innovation Promotion Fund was supported this work (project № Y-62168).

# MULTI-COLORED EMISSION AND LUMINESCENT DETECTION BY A SERIES OF LANTHANIDE METAL-ORGANIC FRAMEWORKS.

*Vasileva A.A.*<sup>1</sup>, *Demakov P.A.*<sup>2</sup>

<sup>1</sup>Novosibirsk State University, Novosibirsk, Russia

<sup>2</sup>Nikolaev Institute of Inorganic Chemistry

Siberian Branch of Russian Academy of Sciences, Novosibirsk, Russia

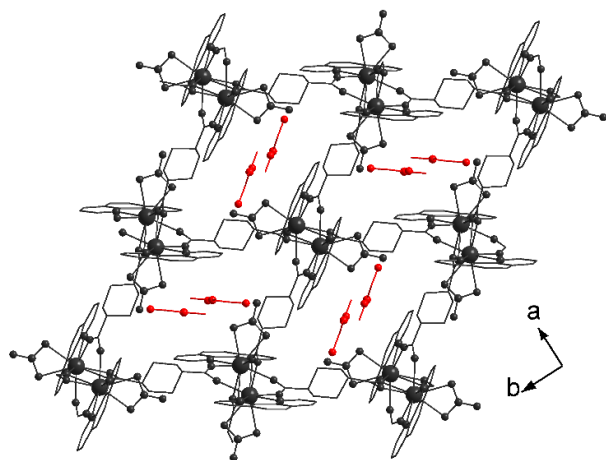
Student

[a.vasileva2@q.nsu.ru](mailto:a.vasileva2@q.nsu.ru)

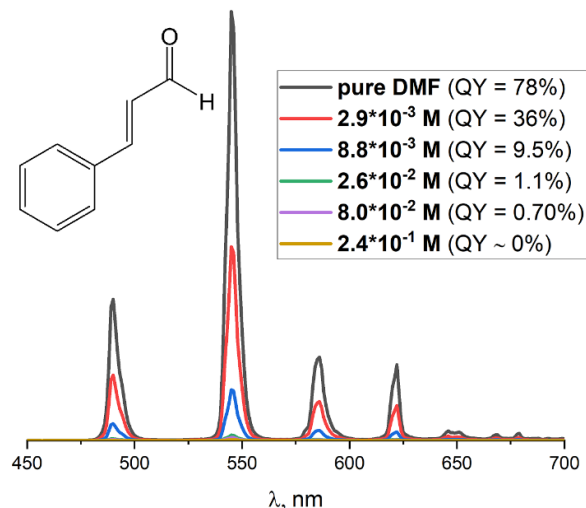
Metal-organic frameworks (MOFs) are hybrid crystalline porous materials consisting of metal ions or clusters bound by organic ligands. Metal-organic frameworks are characterized by a unique structural diversity, due to which successful control of the topology, porosity and functionality of the framework could be achieved [1]. Recently, the use of MOFs as luminescent sensors has been extensively studied due to their tunable porosity and chemical nature, as well as high crystallinity. In addition, permanently porous MOFs can be reactivated and used for several cycles without loss of crystallinity and luminescent characteristics [2].

In this work, coordination polymers  $[\text{Ln}(\text{phen})(\text{NO}_3)(\text{chdc})]\cdot\text{DMF}$  ( $\text{Ln}^{3+} = \text{Y}^{3+}, \text{Eu}^{3+}$  or  $\text{Tb}^{3+}$ ; phen = 1,10-phenanthroline;  $\text{H}_2\text{chdc}$  = trans-1,4-cyclohexanedicarboxylic acid; DMF = N,N-dimethylformamide) were synthesized and characterized. These compounds have a porous structure with one-dimensional channels. Compounds demonstrate blue (Y), green (Tb) and red (Eu) luminescence in solid state. Their isostructurality made it possible to synthesize mixed-metal samples, the emission color of which is controlled by the ratio of metal salts during the synthesis. The luminescence quantum yields for the mixed-metal samples reach 84%.

The porosity of the obtained framework allowed us to probe its luminescent response on the inclusion of various aldehydes and nitroaromatic compounds. The emission of terbium-based MOF suspension in DMF was found to be quenched by cinnamaldehyde with a decrease in the quantum yield from 78% in pure DMF to almost zero at concentrations of cinnamaldehyde higher than  $10^{-2}$  M. Therefore, a new compound  $[\text{Tb}(\text{phen})(\text{NO}_3)(\text{chdc})]\cdot\text{DMF}$  is a perspective sensor for the detection of traces of cinnamaldehyde in natural and industrial samples.



**Figure 3.** The coordination network  $[\text{Ln}(\text{phen})(\text{NO}_3)(\text{chdc})]$  (black) and the location of guest DMF molecules (red).



**Figure 2.** The luminescence spectra of  $[\text{Tb}(\text{phen})(\text{NO}_3)(\text{chdc})]$  suspended in DMF solutions of cinnamaldehyde.

## References

- [1] H. Li, M. Eddaoudi, M. O'Keeffe, O. M. Yaghi, *Letters to nature*, **1999**, 402, 276–279.
- [2] Yu. Cui, Ya. Yue, G. Qian, and B. Chen, *Chemical Reviews*, **2012**, 112, 1126–1162.



UNUSUAL REACTIVITY OF *N*-TRIMETHYLSILYLATED 4-DIMETHYAMINOPYRIDINES  
TOWARDS ORGANOLITHIUMS

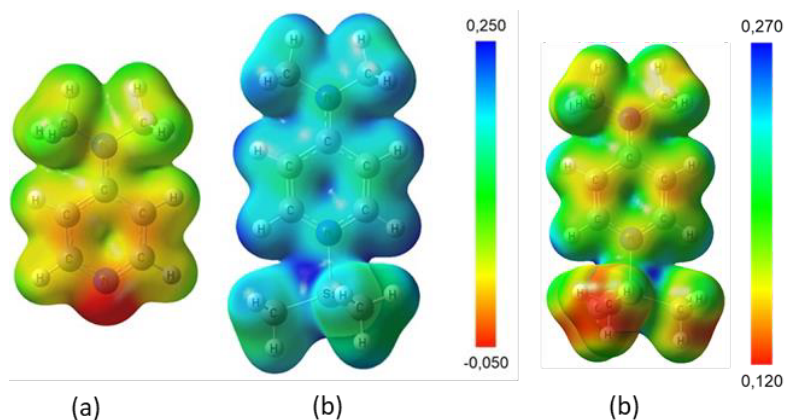
*Verkhov V. A., Antonov A. S.*

Saint Petersburg State University, Saint Petersburg, Russia

Student

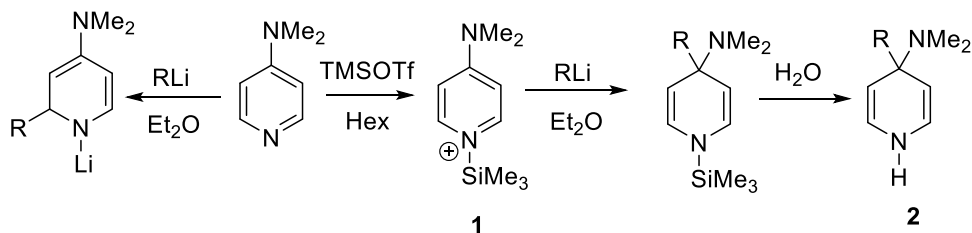
[valeriiverhov@mail.ru](mailto:valeriiverhov@mail.ru)

Six membered nitrogen heterocycles, such as pyridine and quinoline generally display reactivity towards organolithium at the position neighboring to the hetero atom. Thus, due to the localization of the most positive charge both metalation and nucleophilic addition of organometallics occurs to the position 2(6). Introduction of electron donating groups, such as NMe<sub>2</sub>, does not significantly change electron density distribution, keeping positions 2(6) the most reactive (Figure 1a). In this work we performed the study of the influence of the addition of a trimethylsilyl (TMS) protecting group on the nucleophilic addition reaction in 4-dimethylaminopyridine (DMAP) and 4-dimethylaminoquinoline (DMAQ). With the use of quantum chemical calculations, it was found that *N*-silylation of DMAP significantly increases positive charge on all ring atoms, with positions 2,4 and 6 being affected the most (Figure 1b).



**Figure 1.** Electron density distribution in DMAP before (a) and after (b) *N*-trimethylsilylation.

We have demonstrated that *N*-silylation “flips” the reactivity of DMAP: treatment of **1** with organolithiums (nBuLi, MeLi and PhLi) surprisingly leads to the formation of dihydropyridines **2** after hydrolysis (figure 2). We attribute this unprecedented result to two major effects of SiMe<sub>3</sub> group. First, its bulkiness sterically hinders the addition to the positions 2(6). Second, above mentioned increase of positive charge facilitated the nucleophilic attack to the position 4.



**Figure 2.** Interaction of DMAP with organolithiums before and after *N*-trimethylsilylation.

Discovered reaction for the first time opens the way for the selective high yielding synthesis of 4,4-disubstituted dihydropyridines via simple *one-pot* trimethylsilylation and treatment with suitable organolithium reagent.

TERBIUM AND EUROPIUM AROMATIC CARBOXYLATES IN THE POLYSTYRENE  
MATRIX: THE FIRST METAL-ORGANIC-BASED MATERIAL FOR HIGH  
TEMPERATURE THERMOMETRY

*Vialtsev M.B.*<sup>1</sup>, *Tcelykh L.O.*<sup>2</sup>, *Utochnikova V.V.*<sup>1,2,3</sup>

<sup>1</sup>Department of Materials Science, Moscow State University, Moscow, Russia

<sup>2</sup>Department of Chemistry, Moscow State University, Moscow, Russia

<sup>3</sup>SIA Evolved, Puskina iela 1A-24, Riga, LV-1050, Latvia

Student

[mikhail.vialtsev@icloud.com](mailto:mikhail.vialtsev@icloud.com)

The high-precision luminescent thermometry is indispensable in both science and in industry when it is required to measure the temperature of small, fast-moving, or hard-to-reach objects, or when physical contact is impossible. One of the ambitious and fastest growing industries is high temperature luminescence thermometry, where the main applications are temperature measurement of engine components and surface mapping. The most promising materials for luminescence thermometry are coordination compounds of lanthanides, in particular terbium and europium. Their advantages include narrow emission bands with a constant position and high luminescence intensity, which, despite the low absorptive capacity of the lanthanides themselves, is achieved due to the “antenna” effect. By combining complexes of different lanthanides, we can use the most effective temperature response - LIR (the ratio of the integrated intensities of the luminescence bands of two lanthanides), which eliminates the need for additional thermometer calibrations and special requirements of use due to the “internal standard”.

However, the antenna effect, which multiply increases the luminescence brightness of lanthanide compounds, is observed only in the case of coordination compounds with organic ligands, which are significantly inferior in thermal stability to inorganic salts. That is why most of the works on luminescence thermometry are devoted specifically to inorganic compounds of lanthanides. However, we succeeded for the first time to find lanthanide aromatic carboxylates that combine high thermal stability (up to 400-600 °C) and high luminescence intensity, significantly exceeding that of inorganic compounds. Therefore, the aim of this work is to test the possibility of using terbium and europium carboxylates for high-temperature luminescence thermometry.

As an object of study we have chosen a finely dispersed mixture of Eu(mfb)<sub>3</sub>BPhen and Tb(czb)<sub>3</sub> (Hmfb is monofluorobenzoic acid, BPhen is bathophenanthroline, Hczb is 4-(9H-carbazol-9-yl)benzoic acid, doped into a polystyrene matrix to ensure film formation and uniform distribution of complexes. Polystyrene was chosen as a matrix due to its high thermal stability, ease of use and application, and also non-toxicity. LIR was used as the temperature response 
$$LIR = \frac{I(Tb^{457nm})}{I(Eu^{612nm})}$$

As a result, the first organic composite material for high temperature thermometry based on lanthanide coordination compounds (Tb(czb)<sub>3</sub> and Eu(mfb)<sub>3</sub>BPhen), doped into polystyrene matrix, was obtained. It was shown that the resulting material is amorphous, thermally stable up to 260°C, and does not contain water molecules, which could affect the accuracy of temperature measurements; its PLQY at room temperature is very high (75%). Temperature dependent luminescence studies proved the possibility of using the most convenient temperature response LIR in the range of 25-200°C, and sensitivity  $Sr = 2,2\%/^{\circ}C$  and temperature resolution  $\delta T = 0,92^{\circ}C/\%$  were reached.

Moreover, for first time we compared two options of luminophore composition in order to find the most efficient one: in the form of a mixture of two monometallic coordination compounds of lanthanides and in the form of one bimetallic compound of two metals. For this case as an object of study we have chosen mixtures of Tb(Bz)<sub>3</sub>Phen, Eu(Bz)<sub>3</sub>Phen and TbEu(Bz)<sub>3</sub>Phen (HBz is a benzoic acid, Phen is phenanthroline) doped into a polymer matrix. The role of the matrix was also played by polystyrene for the above reasons.

Therefore, we found that on the one hand, due to the absence of additional temperature-dependent processes of energy transfer between metals the sensitivity of a material based on a mixture of monometallic complexes is lower than that based on a bimetallic complex. However, on the other hand, the absence of this process slows down the extinction of one of the lanthanide ions, thereby significantly increasing the temperature range of applicability of the thermometer. In the case of a bimetallic complex vice versa. Thus, the sensitivity and temperature range of applicability of a luminescent thermometer are interdependent. Therefore, when designing a material for thermometry, it is necessary to wisely choose the most suitable option (a mixture of two monometallic complexes or one bimetallic complex of lanthanides) in order to meet application requirements.

Acknowledgements. This work was supported by the Russian Science Foundation (grant 20-73-10053).

In recent years, aqueous rechargeable batteries are widely explored because of their high safety and low cost. Among them, zinc-ion batteries (ZIBs) are promising energy storage devices due to low zinc oxidation potential, high abundance, high theoretical capacity (820 mAh·g<sup>-1</sup>) and nontoxicity. Many types of cathode materials based on inorganic or organic compounds were proposed [1].

Vanadium (V) oxide V<sub>2</sub>O<sub>5</sub> is an attractive cathode material for ZIBs because of its layered structure, high specific capacity and low cost. Nevertheless, there are several drawbacks of this material like cathode dissolution, structural instability (due to high charge density on Zn<sup>2+</sup> ion), low electronic conductivity and low voltage of redox processes (near 0.4 and 0.8 V vs Zn/Zn<sup>2+</sup>). To overcome these problems, different strategies can be applied such as surface modification (by graphene, carbon nanotubes, conducting polymers) nanostructuring the materials with specific architecture, introducing other metal ions and changing the electrolyte composition [2].

In this work, composite material V<sub>2</sub>O<sub>5</sub> coated by poly(3,4-ethylenedioxythiophene) (PEDOT) was proposed as cathode material for ZIBs. To obtain that composite material, V<sub>2</sub>O<sub>5</sub> powder was mixed with EDOT monomer (1.1 mM V<sub>2</sub>O<sub>5</sub> with 0.42 mM EDOT) and placed on a glass test-tube for uniform heating using a microwave digestion system at 120 (for 1 h) and 170 (2 h). Then the product was washed by deionized water and ethanol and dried at 80 under air. After that, the product obtained was characterized by energy dispersive X-ray and thermogravimetric analyses to evaluate the amount of PEDOT on the oxide surface and by scanning electron microscopy. The average PEDOT content was closed to 2%.

Electrode materials were prepared by mixing of V<sub>2</sub>O<sub>5</sub> and V<sub>2</sub>O<sub>5</sub>/PEDOT (70 wt.%) with carbon black (20 wt.%) and polyvinylidene fluoride (10 wt.%) dissolved in N-methyl pyrrolidone until homogenous. The resulting viscous slurry was cast on the carbon paper and titan foil, dried under vacuum and pressed. Coin cells CR 2032 were assembled vs. Zn foil as anode with 3 M ZnSO<sub>4</sub> as electrolyte. Whatman glass microfiber was used as separator. Electrochemical performance was performed by galvanostatic charge/discharge and cyclic voltammetry in a potential range 0.3 – 1.4 V vs. Zn/Zn<sup>2+</sup>. We compared the electrochemical characteristics and morphology of V<sub>2</sub>O<sub>5</sub> and V<sub>2</sub>O<sub>5</sub>/PEDOT-based electrodes by electrochemical techniques mentioned above, scanning electron microscopy, energy dispersive X-ray analysis and X-ray photoelectron spectroscopy.

### References

- [1] Zhang X., Wang L., Fu H. *J. Power Sources* **2021**, 493, 229677.  
[2] Zhang W., Zuo C., Tang C., Tang W., Lan B., Fu X., Dong S., Luo P. *Energy Technol.* **2021**, 9, 1–20.

Acknowledgements. This work was supported by Russian Foundation for Basic Research (project No 21-53-53012). Scientific research were performed at the Interdisciplinary Center for Nanotechnology and the Center for Thermogravimetric and Calorimetric Research of Research park of Research Park of Saint Petersburg State University.

Vypritskaya A.I.<sup>1</sup>, Kamenskii M.A.<sup>1</sup>, Eliseeva S.N.<sup>1</sup>, Kondratiev V.V.<sup>1</sup>

<sup>1</sup>Saint Petersburg State University, Saint Petersburg, Russia

Student

[lina.vypr@gmail.com](mailto:lina.vypr@gmail.com)

Lithium manganese spinel  $\text{LiMn}_2\text{O}_4$  (LMO) is a well-known cathode material for lithium-ion batteries due to its low cost, environmentally friendliness and high voltage (near 4.1 V vs.  $\text{Li}/\text{Li}^+$ ). Furthermore, this material was applied for aqueous batteries and supercapacitors. Among them, hybrid zinc-lithium (Zn/Li) aqueous rechargeable batteries have attracted a great attention owing to low oxidation potential of zinc (-0.76 V vs.  $\text{H}_2/\text{H}^+$ ), high abundance and nontoxicity.

Nevertheless, the main drawbacks of LMO are poor electronic conductivity and manganese dissolution during charge/discharge processes which leads to moderate capacity fading during long-term cycling. The most commonly used approach to eliminate these drawbacks is modification of electrolyte composition. It was demonstrated that addition of indifferent salts like ammonium chloride [1] or development of high-concentrated electrolytes ("water-in-salt") [2] allows stabilizing electrochemical characteristics of LMO-based cathode materials because of increasing the ionic conductivity and preventing gas evolution reactions. For other manganese-based cathodes for zinc aqueous batteries manganese (II) salt can be added to increase stability during long cycling [3] due to decrease of  $\text{Mn}^{\text{IV}}$  dissolving.

In our work, a detailed investigation of electrochemical performance of LMO as cathode material for hybrid Zn/Li batteries was performed with three types of aqueous sulfate electrolytes: pure zinc sulfate, mixture of zinc and lithium sulfates and three-component electrolyte  $\text{ZnSO}_4 / \text{Li}_2\text{SO}_4 / \text{MnSO}_4$ . Electrodes were prepared in accordance with conventional technique and tested vs. zinc foil by cyclic voltammetry and galvanostatic charge/discharge.

We demonstrated that application of sulfate-based two-component electrolytes allows achieving a remarkable capacity values at moderate (1 C) and high (5 C) current densities (120 and 90  $\text{mAh}\cdot\text{g}^{-1}$ , respectively). Addition of manganese sulfate leads to increasing the capacity at current density 1 C. The morphology and phase composition of electrodes were analyzed by X-ray diffraction and energy dispersive X-ray analysis.

#### References

- [1] Mainar A.R., Iruin E., Blázquez J.A. *Energy Technol.* **2020**, 8, 2–8.
- [2] Han J., Mariani A., Varzi A., Passerini S. *J. Power Sources* **2021**, 485, 229329.
- [3] Qiu C., Zhu X., Xue L., Ni M., Zhao Y., Liu B., Xia H. *Electrochim. Acta* **2020**, 351, 136445.

Acknowledgements. This work was supported by Russian Foundation for Basic Research (project No 21-53-53012). Scientific research were performed at the Center for X-ray Diffraction Methods and the Interdisciplinary Center for Nanotechnology of Research Park of Saint Petersburg State University.

## LITHIATION OF 2,4,5,7-TETRABROMO-1,8-BIS(DIMETHYLAMINO)NAPHTHALENE

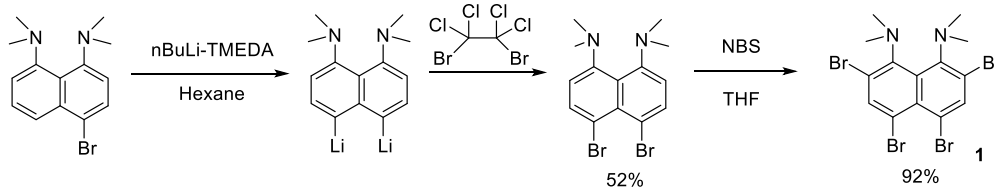
Yakubenko A.A., Antonov A.S.

Saint Petersburg State University, Saint Petersburg, Russia

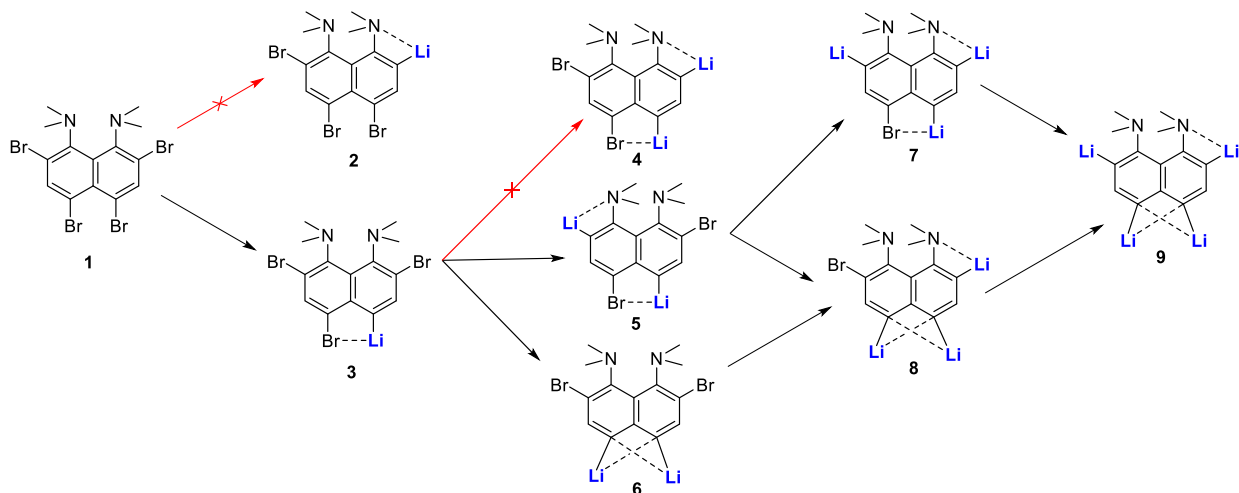
Student

[yakubenkoartyom@gmail.com](mailto:yakubenkoartyom@gmail.com)

Halogen-lithium exchange is one of the most common methods for the synthesis of organolithium reagents. For the last nine decades many features affecting halogen-metal exchange such as polylithiation or influence of directing groups have been studied. However, these investigations were performed mostly for benzene derivatives, leaving condensed systems such as naphthalene barely studied. Here we present the investigation on halogen-lithium exchange in the 2,4,5,7-tetrabromo-1,8-bis(dimethylamino)naphthalene **1** - convenient model for the better understanding of the peculiarities of naphthyllithiums formation. Derivative **1** includes several directing situations and possibility of up to four bromine atoms exchange. Tetrabromide **1** was prepared via bromination of 4-bromo-1,8-bis(dimethylamino)naphthalene (figure 1).

Figure 1. Synthesis of tetrabromide **1**

We have found that step by step halogen-lithium exchange in **1** proceeds as shown on figure 2. Thus, first exchange of bromine occurs in *para*-position with formation of **3**. We believe that formation of less strained five membered metalocycle via coordination of lithium with bromine atom in **3** is more preferable than coordination with NMe<sub>2</sub> group in **2**. Second exchange occurs less selective leading to the formation of the mixture of **5** and **6** – both stabilised by at least one strained four membered metalocycle. Third lithiation yields the mixture of **7** and **8** with the latter being major product due to the better saturation of the coordination demands of lithium atoms. Finally, we have demonstrated the possibility of all four bromine atoms exchange with the formation of the **9**. The latter is the first representative of tetralithionaphthalenes and convenient precursor for the synthesis of 2,4,5,7-tetrasubstituted-1,8-bis(dimethylamino)naphthalenes.

Figure 2. Step by step bromine-lithium exchange in tetrabromide **1**

# SEPARATION OF BENZENE AND CYCLOHEXANE BY ZINC PADDLE-WHEEL METAL-ORGANIC FRAMEWORKS

*Yudina Yu.A.*<sup>1, 2</sup>, *Demakov P.A.*<sup>2</sup>, *Dybtsev D.N.*<sup>2</sup>

<sup>1</sup>Novosibirsk State University, Novosibirsk, Russia

<sup>2</sup>Nikolaev Institute of Inorganic Chemistry, Novosibirsk, Russia

Student

[y.yudina@g.nsu.ru](mailto:y.yudina@g.nsu.ru)

Separation of benzene and cyclohexane mixtures is one of the most challenging problems in chemistry. Lately the solution has been searched in the field of porous materials. Metal-organic frameworks (MOFs) are a prominent class of porous compounds and thus can be studied in relation to the mixture separation.

In this work, three previously reported zinc-based MOFs [1-2] were synthesized to study their adsorption characteristics for benzene and cyclohexane both in vapor and in liquid phase. The formulas of the compounds are  $[Zn_2(bdc)_2(dabco)]$  (**1**),  $[Zn_2(tdc)_2(dabco)]$  (**2**) and  $[Zn_2(sedc)_2(dabco)]$  (**3**) ( $bdc^{2-}$  = 1,4-benzenedicarboxylate,  $tdc^{2-}$  = 2,5-thiophenedicarboxylate,  $sedc^{2-}$  = 2,5-selenophenedicarboxylate). The frameworks in **1** – **3** are isorecticular and contain the system of intersecting channels, the internal surface of which is decorated by S or Se atoms (in **2** and **3**, respectively) or not decorated in the terephthalate-based **1**. The detailed comparison of the adsorption data in such MOF series unveiled the role of heavy atom in the properties of isorecticular frameworks with similar geometry and porosities.

The adsorption isotherms of benzene and cyclohexane vapors were measured at 298K for all the compounds, some of the obtained characteristics are given in the table below.

**Table 1.** Adsorption characteristics for compounds 1-3.

	$S_{BET}$ , m <sup>2</sup> /g	$V_{max}^{benzene}$ , cm <sup>3</sup> /g	$V_{max}^{cyclohexane}$ , cm <sup>3</sup> /g	$K_H^{benzene}/K_H^{cyclohexane}$
<b>1</b>	1877	153,8	117,1	2,86
<b>2</b>	1671	142,9	106,3	1,81
<b>3</b>	1562	123,6	100,6	1,13

The saturated adsorption of benzene is higher than of the cyclohexane by 20-26%. It can be explained with the smaller molecular size of benzene compared with that of cyclohexane. In order to study the selectivity of adsorption from liquid phase samples were soaked in mixture with initial benzene : cyclohexane volume ratio 1:9. Such composition imitates industrially obtained cyclohexane, which contains benzene admixture. After immersion the solid samples were then dried and dissolved. The ratio of benzene to cyclohexane adsorbed was determined by <sup>1</sup>H NMR analysis.

**Table 2.** Ratio of benzene to cyclohexane absorbed from liquid mixture.

<b>1</b>	2,17
<b>2</b>	1,93
<b>3</b>	1,39

To our surprise, the terephthalate-based parent framework **1** demonstrated the best C<sub>6</sub>H<sub>6</sub>/C<sub>6</sub>H<sub>12</sub> selectivity results in all the carried experiments. This fact can possibly explained by the sterical factors caused by increase of atomic radii in the row C < S < Se. Furthermore, single-crystal x-ray diffraction analysis of **3**·C<sub>6</sub>H<sub>6</sub> inclusion compound was successfully carried out and confirmed the different location of guest benzene molecules, in comparison to the previously reported structure **1**·2C<sub>6</sub>H<sub>6</sub> [3].

## References

- [1] Bolotov V.A., Kovalenko K.A. *Inorg. Chem.* **2018**, 57, 9, 5074–5082
- [2] Demakov P.A., Volynkin S.S. *Molecules* **2020**, 25, 19, 4396
- [3] Dybtsev D.N., Chun H. *Angew. Chem. Int. Ed.* **2004**, 43, 38, 5033–5036.

Acknowledgements. This work was supported by the Russian Science Foundation (project No 18-13-00203).

CRYSTALLOGRAPHIC DESIGN OF CATIONIC IRIDIUM(III) COMPLEXES WITH POLYIODIDE ANIONS –  
BETTER UNDERSTANDING OF “DYE-MEDIATOR” INTERACTIONS IN DSSC

*Zakharov A. Yu.*<sup>1</sup>, *Kalle P.*<sup>1,2</sup>, *Bezzubov S. I.*<sup>1</sup>

<sup>1</sup>Kurnakov Institute of General and Inorganic Chemistry, Moscow, Russia

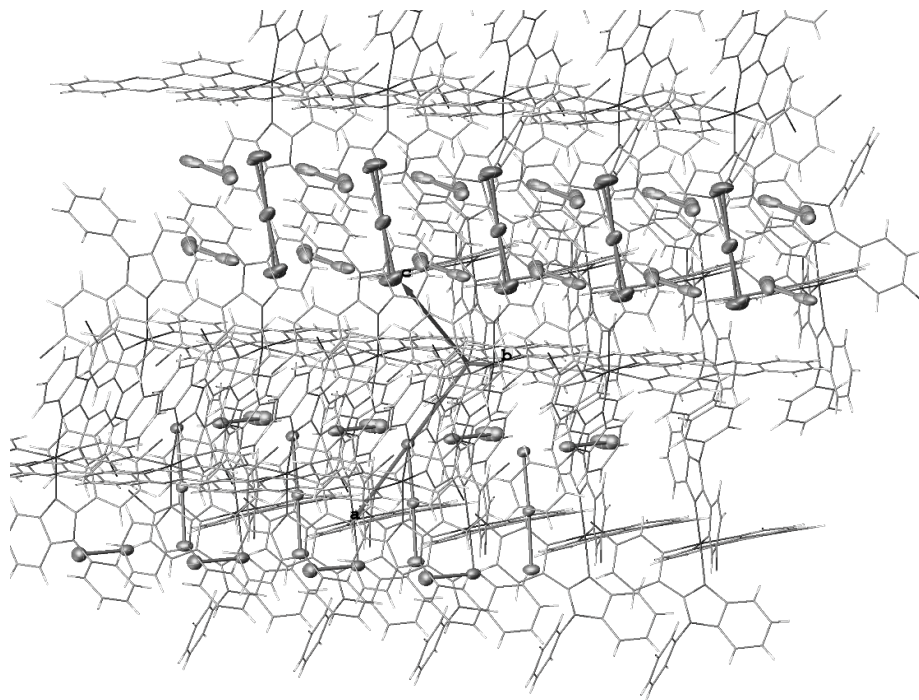
<sup>2</sup>Moscow State University, Moscow, Russia

PhD student

[alexan.zakharov@ya.ru](mailto:alexan.zakharov@ya.ru)

One of the effective ways of solar energy conversion requires usage of dye-sensitized solar cells (DSSC). The development and production of stable and efficient devices requires understanding a number of fundamental processes occurring in the cell. One of such processes is a reduction of the oxidized dye form (the Ir(III) complex) by mediator (RedOx  $I_3^-/I^-$  pair). However, there are another side processes in the cell: one of the most harmful is a recombination of electron from the excited photosensitizer with the iodide-anion. It is necessary to create models with charge separation for investigation of such side processes of electron transfer between the dye and the mediator. The research of solution systems is rather complicated due to particles mobility, so we consider co-crystals of cationic complexes of a dye with mediator anions as a satisfactory model system. In this case, the essence of the processes occurring in the cell is preserved, and the close packing additionally facilitates the electron transfer.

Depending on the initial iodine concentration various polyiodide architectures could be obtained in the resulting crystals, from insular triiodides to infinite polyiodide chains. Obtained objects were systematically studied by single crystal X-ray diffraction analysis. It was shown that the presence of carboxyl groups in the «anchoring» ligand leads to formation of crystal packing by strong hydrogen bonds, and polyiodide anions are isolated in crystal voids. When there are no carboxyl groups in anchor ligand, the crystal packing is formed due to weaker direct interactions. So the variability of formed polyiodide anions increases, which results in a possibility of the formation of endless polyiodide chains. We assume that in such systems a charge transfer between Ir(III) complex and infinite polyiodide chain can occur.



**Figure 1.** Structure of Ir(III) complex with infinite polyiodide chains.

# CRYSTALLIZATION OF MOFS IN MAGNETIC LEVITATION

Zavyalova A.G., Kladko D.V., Vinogradov V.V

ITMO University, Saint Petersburg, Russia  
Student

[Zavyalova@scamt-itmo.ru](mailto:Zavyalova@scamt-itmo.ru)

Metal-organic frameworks are one of the most prospective class of compounds. Nowadays, obtaining large MOF single crystals and their applicability in optoelectronics and separations are the tasks of special interest. The existing synthesis methods of large MOF single crystals, such as solvothermal methods, microfluidic methods, and reaction parameters control have a number of disadvantages. For instance, solvothermal strategies require high temperatures and pressures. As for microfluidic methods, the size of crystals, obtained by these strategies, is relatively small. This report presents a novel synthesis method for obtaining large ZIF-8 single crystals in magnetic levitation conditions. We have developed a magnetic levitation system, optimized the conditions of reaction and characterized the obtained crystals.

Microgravitation conditions, like magnetic levitation conditions, are characterized by a lack of sedimentation and free convection. The precursors' diffusion is slow in these conditions, which leads to a decrease of nucleation and growth rate. Moreover, a low growth rate can lead to a decrease in the number of defects in crystals. Thus, we expect to obtain large single ZIF-8 crystals with high order structure.

The magnetic levitation system consists of a magnetic chamber, paramagnetic solution, and diamagnetic solution. Under the applied magnetic field, paramagnetic components (the magnetite in a non-polar solvent) will tend to the maximum of the magnetic field, and diamagnetic components (the MOFs precursors in water) will tend to the minimum of the magnetic field. Magnetic forces will compensate the gravity force effecting on the diamagnetic components. For our magnetic system, we have chosen the superparamagnetic iron oxide nanoparticles (SPION) as a component of the paramagnetic solution, which possess high magnetic susceptibility. Paramagnetic solution and diamagnetic solution were divided through the emulsion to avoid magnetite deposition on the MOF crystals.

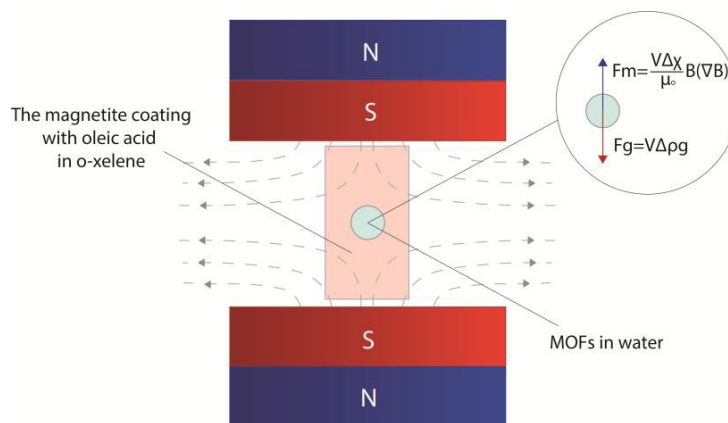


Figure 1. Reaction.

The object of our research is zeolitic metal-organic frameworks ZIF-8 there are one of the most frequently used MOF crystals for diverse application. The several syntheses series were held in our work with different duration. We found a significant difference in crystal size that were obtained through 10 minutes and 1 hour. It was defined that under conditions of magnetic levitation for 10 minutes, MOFs crystals are obtained 2 times more than in emulsion. Crystals did not form under gravity conditions. In the reaction proceeding for 1 hour, the size of the crystals is 2 times larger than under emulsion and 10 times larger than under normal gravity conditions. Further, we obtained large single crystals ZIF-8 through optimization molar ratio of precursors, metal source, and saturation of precursors. The largest crystals were synthesized with zinc nitrate hexahydrate as a metal source explaining in lower alkalinity of the solution compared with zinc acetate. The obtained particles were characterized through scanning electron microscopy (SEM). Accordingly, to the SEM images, the crystals with an average size - 10  $\mu\text{m}$  were obtained in magnetic levitation conditions and with a size 5  $\mu\text{m}$  in the control emulsion.

In conclusion, we identified that MOF crystals grow larger in magnetic levitation conditions than in gravity conditions. The obtained results indicate that the crystallization of metal-organic frameworks in magnetic levitation is promising.

Acknowledgements. This work was supported by the Ministry of Science and Higher Education of Russian Federation, goszadanie no. 2019-1075



Zefirova P.M.

Saint Petersburg State University, Saint Petersburg, Russia

Student

[st086859@student.spbu.ru](mailto:st086859@student.spbu.ru)

Group 14 element tetrahalides are Lewis acids and can form donor-acceptor complexes with nitrogen-containing ligands [1, 2]. It is known that tin tetrachloride forms with pyrazine (pyz) the complex of 1:2 composition  $SnCl_4 \cdot 2pyz$  [2]. However, pyz can behave not only as monodentate ligand, but also as bifunctional one [3]. Therefore, in the present work we report syntheses and characterization of complexes of  $MX_4$  (M = Si, Sn) with pyz in the initial ratio  $MX_4:pyz = 1:1$  (M = Si, Sn).

Due to moisture and air sensitivity of group 14 element tetrahalides and the reaction products, syntheses and preparation of samples for physical measurements were carried out in wholeglass apparatus under vacuum or under an argon atmosphere in a glovebox Inertlab 2GB. Initial  $MCl_4$ -to-pyz ratio was 1.08:1 and 1:1.06 for  $SiCl_4$  and  $SnCl_4$ , respectively.  $MCl_4$  was sublimed to pyz and the reagent mixture was kept at room temperature for 9 days ( $SiCl_4$ ) and 7 days ( $SnCl_4$ ). Then the excess of  $MCl_4$  was removed by sublimation into special compartment and sealed off. For  $SiCl_4$  additional syntheses were performed in the glove box using a solvent (dichloromethane and toluene). Single crystals suitable for X-ray structure analysis (XRA) were grown from solutions at  $-28^\circ C$ .

Products were characterized by mass spectrometry, IR spectroscopy, XRA and Powder X-Ray Diffraction analyses (PXRD). The results of XRA showed that only pyz and  $[pyzH]Cl$  were isolated from toluene and  $CH_2Cl_2$  solutions, respectively. Thus, complex of  $SiCl_4$  with pyz does not crystallize from the solution. However, IR spectrum for sample synthesized under vacuum showed that pyz was coordinated to  $SiCl_4$ . The complex  $SnCl_4 \cdot 2pyz$  was characterized by PXRD resulting in a powder pattern that matches that of known  $SnCl_4 \cdot 2pyz$  complex. Observation of ions  $SiCl_3C_4H_4N_2^+$  (0,3%) and  $SnCl_3C_4H_3N_2^+$  (0,7%) in mass spectra indicates existence of the compounds containing Si-N and Sn-N bonds in the gas phase.

To conclude, we have synthesized two complexes  $MCl_4$  with pyz (M = Si, Sn). According to obtained results, the solid complex  $SiCl_4$  with pyz is formed in synthesis under vacuum. From the synthesis in a ratio  $SnCl_4:pyz = 1:1$  already known complex  $SnCl_4 \cdot 2pyz$  is formed. Both complexes dissociate into free fragments upon heating.

### References

- [1] Davydova E.I., Sevastianova T.V., Suvorov A.V., Timoshkin A.Y. *Coord. Chem. Rev.* **2010**, 254, 2031-2077
- [2] Grigsby W.A., Morien T.S., Raston C.L., Skelton B.W., White A.H. *Aust. J. Chem.* **2004**, 57, 507-508
- [3] Sevastianova T.V., Bodensteiner M., Lisovenko A.S., Davydova E.I., Scheer M., Susliakova T.V., Krasnova I.S., Timoshkin A.Y. *Dalt. Trans.* **2013**, 42, 11589-11599

Acknowledgement: This work was supported by the Russian Science Foundation (project 18-13-00196). X-ray powder diffraction measurements were performed at the «Center for X-ray Diffraction Studies» of the Research park of St. Petersburg State University.

BIS(PERFLUOROPYRIDIN-4-YL)SELANE AND BIS(PERFLUOROPYRIDIN-4-YL)TELLANE  
AS CHALCOGEN BOND DONORS

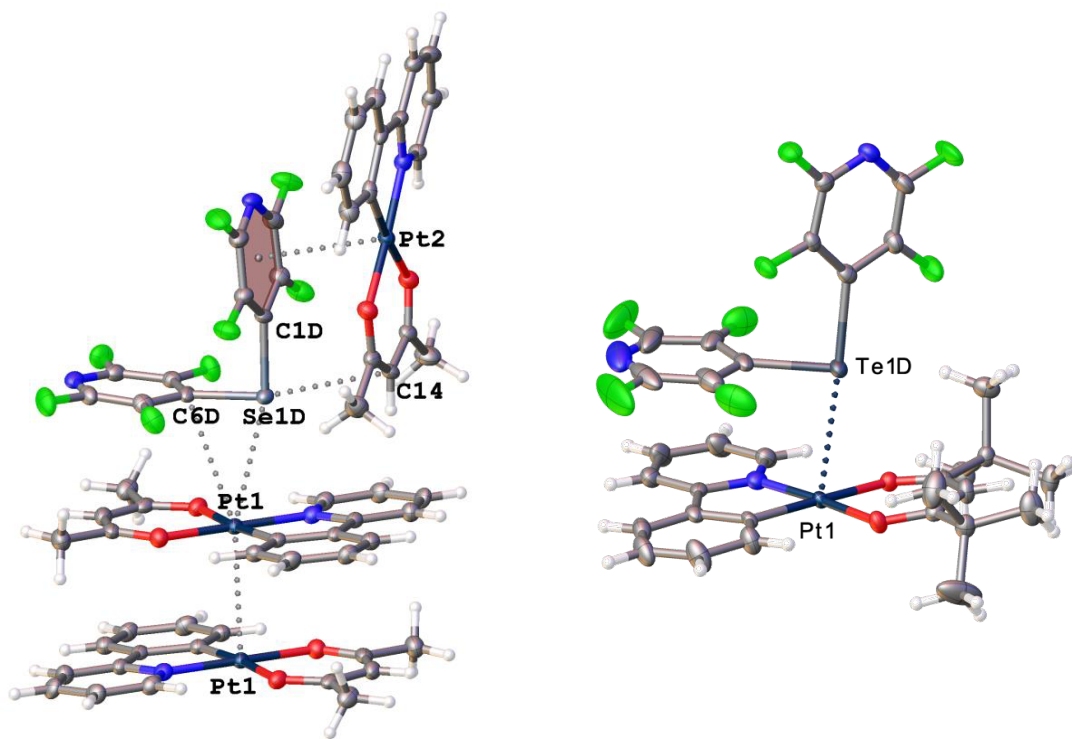
*Zhmykhova M.V., Rozhkov A.V.*

Saint Petersburg State University, Saint Petersburg, Russia

Student

[zhmykhovarita@gmail.com](mailto:zhmykhovarita@gmail.com)

The platinum(II) complexes exhibiting an expressed  $dz^2$ -nucleophilicity of the positively charged metal centers, viz. [Pt(ppy)(acac)] (**1**; acacH is acetylacetonone; ppyH is 2-Ph-pyridine) and [Pt(ppy)(tmhd)] (**2**; tmhdH is 2,2,6,6-tetramethylheptanedione-3,5), were co-crystallized with the chalcogen bond donors  $(4\text{-NC}_5\text{F}_4)_2\text{Ch}$  (Ch = Se, Te) to form two isostructural co-crystals  $1 \cdot \frac{1}{2}(4\text{-NC}_5\text{F}_4)_2\text{Ch}$  and also  $2 \cdot \frac{2}{3}(4\text{-NC}_5\text{F}_4)_2\text{Se}$  and  $2 \cdot (4\text{-NC}_5\text{F}_4)_2\text{Te}$ . The X-ray data for these co-crystals allowed the recognition of the metal-involving chalcogen bond, namely  $\text{Ch} \cdots dz^2\text{-Pt}^{\text{II}}$  (fig. 1). In  $1 \cdot \frac{1}{2}(4\text{-NC}_5\text{F}_4)_2\text{Ch}$ , the  $\text{Ch} \cdots dz^2\text{-Pt}^{\text{II}}$  bonding is accompanied with the  $\text{C} \cdots dz^2\text{-Pt}^{\text{II}}$  interaction, representing a three-center bifurcate, whereas in  $2 \cdot (4\text{-NC}_5\text{F}_4)_2\text{Te}$  the chalcogen bond  $\text{Te} \cdots dz^2\text{-Pt}^{\text{II}}$  is the purely two-center and it is stronger than that in  $1 \cdot \frac{1}{2}(4\text{-NC}_5\text{F}_4)_2\text{Ch}$  due to more efficient orbital overlap. The association of **2** with  $(4\text{-NC}_5\text{F}_4)_2\text{Te}$  and the structure of the formed adduct in  $\text{CDCl}_3$  solutions was studied by  $^1\text{H}$ ,  $^{13}\text{C}$ ,  $^{19}\text{F}$ ,  $^{195}\text{Pt}$ ,  $^{125}\text{Te}$  NMR.



**Figure 1.** Structures of co-crystals  $1 \cdot \frac{1}{2}(4\text{-NC}_5\text{F}_4)_2\text{Se}$  and  $2 \cdot (4\text{-NC}_5\text{F}_4)_2\text{Te}$ .

Acknowledgements. This work was supported by Russian Science Foundation (21-73-10030).

SYNTHESIS AND CHARACTERIZATION OF RHUTHENIUM(II) COMPLEXES  
WITH 2-(1H-TETRAZOL-1-YL)PYRIDINE

*Zhurauleva A.A., Lyakhov A.S., Serebryanskaya T.V.*

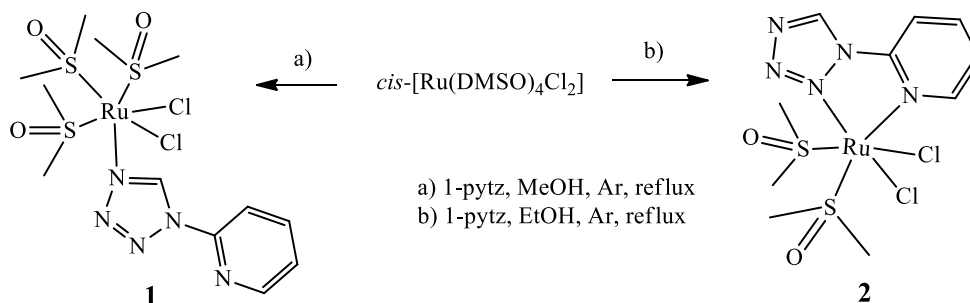
Research Institute for Physical Chemical Problems, Belarusian State University, Minsk, Belarus

Student

[hanna.zhuravleva2000@gmail.com](mailto:hanna.zhuravleva2000@gmail.com)

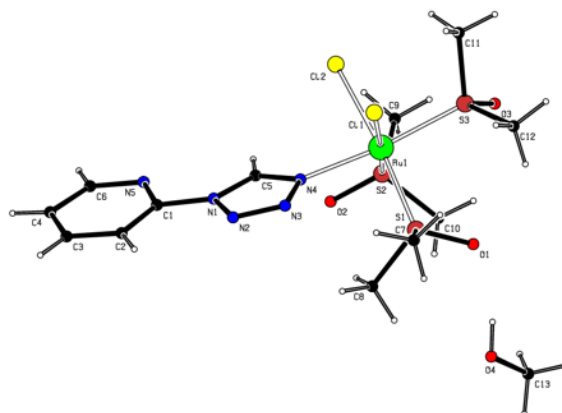
Ruthenium compounds based on functionally substituted tetrazoles provide a promising avenue for the design of therapeutic and diagnostic agents. The compounds offer the potential of reduced toxicity and can be used as viable alternatives to traditional organic drugs [1,2].

In the present study, we report on synthesis and structure of Ru(II)-based complexes with a representative N-tetrazolyl substituted pyridine, namely 2-(1H-tetrazol-1-yl)pyridine [1-pyztz]. The complex [Ru(1-pyztz)(DMSO)<sub>3</sub>Cl<sub>2</sub>] (**1**) was synthesized by the reaction of a specially prepared precursor *cis*-[Ru(DMSO)<sub>4</sub>Cl<sub>2</sub>] with 1-pyztz in methanol under reflux conditions. The complex [Ru(1-pyztz)(DMSO)<sub>2</sub>Cl<sub>2</sub>] (**2**) was synthesized by the reaction of *cis*-[Ru(DMSO)<sub>4</sub>Cl<sub>2</sub>] with 1-pyztz in ethanol under reflux conditions (Fig. 1).



**Figure 1.** Synthesis of ruthenium(II) complexes with 1-pyztz

The resulting complexes were characterized by elemental analyses, HR ESI(+) mass spectrometry, IR-spectroscopy, <sup>1</sup>H and <sup>13</sup>C NMR spectroscopy, and simultaneous thermal analysis. The molecular and crystal structure of [Ru(1-pyztz)(DMSO)<sub>3</sub>Cl<sub>2</sub>]·DMSO was established by single-crystal X-ray diffraction analysis. The complex has a distorted octahedral geometry, in which 1-pyztz coordinates as a monodentate ligand *via* N<sup>4</sup> atom of the tetrazole ring (Fig. 2). According to the data of <sup>1</sup>H NMR spectroscopy, in the structure of **2**, 1-pyztz coordinates as a N,N-chelating ligand *via* the pyridine N atom and N<sup>2</sup> atom of the tetrazole ring.



**Figure 2.** The structure of [Ru(1-pyztz)(DMSO)<sub>3</sub>Cl<sub>2</sub>]·DMSO

### References

- [1] Motswainyana M., Ajibade P.A. *Advances in Chemistry*. **2015**, 1–21  
[2] Monti N. [et al.] *Appl. Organomet. Chem.* **2020**, 34, e5806

Acknowledgements. The work was supported by BRFFR, grant № X20P-066.

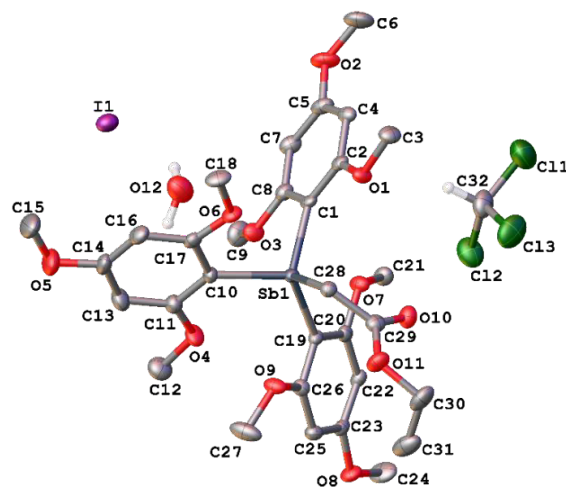
BISMUTH-CONTAINING COMPLEX WITH ANTIMONY-ORGANIC  
CATION {[2,4,6-(MeO)<sub>3</sub>C<sub>6</sub>H<sub>2</sub>]<sub>3</sub>SbCH<sub>2</sub>C(O)OEt}<sup>+</sup>. SYNTHESIS AND STRUCTURE

*Zubakina I.N., Egorova I.V., Zhidkov V.V.*

Blagoveshchensk State Pedagogical University, Blagoveshchensk, Russia  
PhD Student  
[zubakina.92@inbox.ru](mailto:zubakina.92@inbox.ru)

Tetraarylantimony halides with antimony and bismuth iodides form complex compounds [1]. We have previously studied the interaction of *tris*(2,6-dimethoxyphenyl) (ethoxycarbonylmethyl) stibonium iodide with mercury diiodide with the formation of a complex {[2,6-(MeO)<sub>3</sub>C<sub>6</sub>H<sub>2</sub>]<sub>3</sub>SbCH<sub>2</sub>C(O)OEt}<sub>2</sub>[Hg<sub>2</sub>I<sub>6</sub>] [2].

In continuation of these studies, the possibility of alkylation of *tris*(2,4,6-trimethoxyphenyl) antimony with ethyl iodoacetate in chloroform in a molar ratio of reagents of 1:2 was established for the first time in the continued research. Alkylation product – {[2,4,6-(MeO)<sub>3</sub>C<sub>6</sub>H<sub>2</sub>]<sub>3</sub>SbCH<sub>2</sub>C(O)OEt}I – represents crystals of pale yellow color, slightly soluble in acetone, diethyl ether; well soluble in dimethyl sulfoxide ethanol. The IR spectrum of *tris*(2,4,6-trimethoxyphenyl)(ethoxycarbonylmethyl)stibonium iodide contains an absorption band at 1716 cm<sup>-1</sup>, which corresponds to asymmetric stretching vibrations of the carbonyl group [3].



**Fig. 1.** General view {[2,4,6-(MeO)<sub>3</sub>C<sub>6</sub>H<sub>2</sub>]<sub>3</sub>SbCH<sub>2</sub>C(O)OEt}I

According to X-ray diffraction data, the complex consists of cations {[2,4,6-(MeO)<sub>3</sub>C<sub>6</sub>H<sub>2</sub>]<sub>3</sub>SbCH<sub>2</sub>C(O)OEt}<sup>+</sup> and anions I<sup>-</sup> (Fig. 1). The cation has a distorted tetrahedral configuration, as evidenced by the values of the CSbC angles, which are in the range 104.54(15)–113.55(16)°. The Sb–C<sub>Me</sub> distance is 2.130(4) Å, the Sb–C<sub>Ar</sub> distances are in the range 2.083(4)–2.094(4) Å. The interaction studied {[2,4,6-(MeO)<sub>3</sub>C<sub>6</sub>H<sub>2</sub>]<sub>3</sub>SbCH<sub>2</sub>C(O)OEt}I with bismuth (III) iodide was studied. The reaction was carried out in piperidine in a molar ratio of reagents 1:2. Received crystals of red color with So pl. > 200 ° C, readily soluble in polar organic solvents were received.

The frequencies of stretching vibrations of bonds in the spectrum of the complex are at 1101 cm<sup>-1</sup> [ $\nu_s$ (O–C<sub>Me</sub>)], 1041, 1234 cm<sup>-1</sup> [ $\nu_{as}$ (C<sub>Me</sub>–O–C<sub>Ar</sub>)], 2829, 2930 cm<sup>-1</sup> [ $\nu_{s,as}$ (C–H)], 1716 cm<sup>-1</sup> [ $\nu_{as}$ (OCO)].

The absorption bands in the IR spectrum of the compound were assigned in accordance with the data of the works [2, 3].

### References

- [1] Egorova, I.V. Bismuth aryl compounds. Synthesis, structure, application.: Diss ... doct. chem. Sciences : 09.10.2008 / Egorova Irina Vladimirovna. – Nizhny Novgorod, **2008**. – S. 350.
- [2] I.V. Egorova, I.V. Egorova, V.V. Zhidkov, I.P. Grinishak, I.Yu. Bagryanskaya, N.V. Pervukhina, I.V. El'tsov, N.V. Kurat'eva, *Zhurn. inorgan. chemistry*, **2019**, 64 (1), 15-22.
- [3] Nakamoto, K. Infrared and Raman Spectra of Inorganic and Coordination Compounds / K. Nakamoto. – New York: J. Wiley & Sons, **1986**. – 484 pp.



# **NANOCHEMISTRY AND NANOMATERIALS**

## POLYOXOMETALATES AS MULTIFUNCTIONAL PLATFORM FOR CHEMICAL ENGINEERING

Abramov P.A.<sup>1</sup>

<sup>1</sup>Nikolaev Institute of Inorganic Chemistry SB RAS, Novosibirsk, Russia  
Group Leader  
[abramov@niic.nsc.ru](mailto:abramov@niic.nsc.ru)

Polyoxometalates (POM) form a unique field of research combining inorganic, coordination and supramolecular chemistry. The main feature of this class of compounds is structural versatility generating limitless variations for modification of such compounds, in order to tune the structure for desired applications in catalysis, material science, biology or spintronics.

This contribution illustrated our recent progress in the group 5 and 6 polyoxometalate chemistry and will cover the following topics:

– Reactivity of noble metals containing group 6 POM complexes for catalytic applications. Inclusion of noble metal atoms into the POM backbone alters reactivity of the noble metal, due to constrained coordination arrangement by oxoligands, which tend to stabilize high oxidation states and promote click reactions at the ligands. The noble metal containing organometallic-POM hybrids can be used as supramolecular building blocks for new type coordination networks based on  $\pi$ - $\pi$  interactions.

– Self-assembly reactions between simple building blocks producing hierarchically ordered POM- based supramolecular architectures. For example, one-pot synthesis from sodium tungstate, selenic acid and a binuclear molybdenum(V) thiocluster produces large chalcogen-POM associates with up to 76 tungsten atoms. On the other hand, self-assembly in the polyoxoanion/octahedral cluster/ $\gamma$ -cyclodextrin systems gives hierarchy ordered supramolecular complexes based on the specific molecular recognition between the simple components.

– Multifunctional POM based complexes as photovoltaic cells components. The combination of Keggin type POM and perylene diimide based cations results in: i) featured electrochemical behavior combining both POM and cation reduction associated processes; ii) charge separation even at room temperature; iii) photoluminescence; iv) electron transfer properties for photovoltaic cells.

– Core-shell Ag based clusters and polyoxometalates. Perspectives of new type materials combining nanosized Ag-thiolate clusters and polyoxometalates will be demonstrated.

Acknowledgements. This work was supported by Russian Science Foundation (project No 19-73-10027) and Russian President Grant (MD 396.2021.1.3).

# OPTICALLY ACTIVE MATERIALS BASED ON CELLULOSE NANOCRYSTALS MODIFIED BY CARBON DOTS

*Aleksandrova D.D.*<sup>1</sup>, *Navrotskaya A.G.*<sup>1</sup>, *Chekini M.*<sup>2</sup>, *Yakovets I.*<sup>2</sup>, *Kheiri S.*<sup>2</sup>,  
*Krivoshapkina E.F.*<sup>1</sup>, *Kumacheva E.*<sup>1,2</sup>

<sup>1</sup>ITMO University, Saint Petersburg, Russian Federation

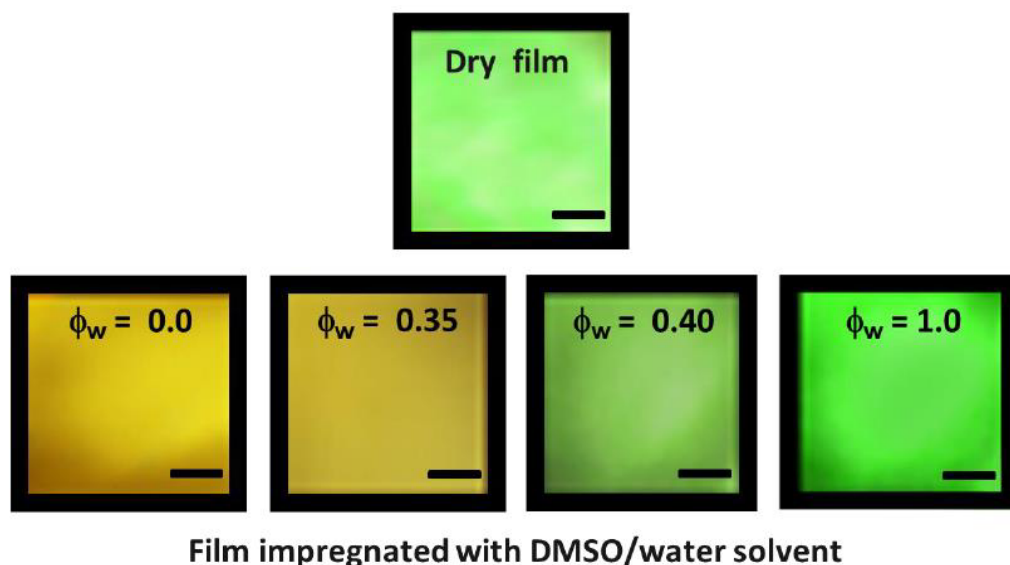
<sup>2</sup>University of Toronto, Toronto, Canada

Student

aleksandrova@scamt-itmo.ru

Food, chemicals and medical products must be transported and stored at proper temperatures. Cold chain includes the use of thermal control [1]. Our study reports a thermochemical indicator (T-indicator) based on cellulose nanocrystals (CNC) modified by carbon dots (C-dots) that exploit the unique melting point variation of DMSO / water mixtures over a wide temperature range and solvatochromic effect of C-dot/CNC. Figure 1 shows the basic principles for determining the temperature increase based on the C-dot / CNC film at different ratios of DMSO: water (1-100: 0, 2-65: 35, 3-60: 40, 4-0: 100).

C-dots are promising zero-dimensional fluorescent nanoparticles. Photoluminescent nanomaterials are being investigated for possible applications in sensor devices, optoelectronic devices, green nanophotonics, bioimaging, cancer treatment, and drug delivery. The use of quantum dots has attracted a lot of attention due to their high solubility in water, durability, photographic stability, sensitivity, and a wide range of radiation [2, 3].



**Figure 1.** Basic principle of the T-indicator based on C-dot/CNC film in different DMSO:water volume ratio (1 - 100:0, 2 - 65:35, 3 - 60:40, 4 - 0:100) under Green light illumination  $\lambda_{\text{ex}} = 530 \text{ nm}$

We investigated the optical and physicochemical properties of hybrid nanomaterials, studied the effect of solvent polarity on the optical properties of C-dot / CNC materials and the effect on properties of parameters such as excitation wavelength dependence, temperature and solvent ratio. Studies have shown that changes in the polarity of the medium cause a change in radiation intensity and wavelength in parallel with a decrease in the proportion of a less polar solvent. We received the films based on a C-dot / CNC hybrid. The results of optical studies revealed the influence of the polarity of the environment and temperature on all studied hybrids. They showed the possibility of their use as effective temperature indicators.

## References

- [1] Kumru, O. S. et al. *Biologicals* **2014**, 42.5, 237-259
- [2] Li D., et al. *Advanced Materials* **2018**, 30(13), 1705913
- [3] Tian Z., et al. *Advanced Optical Materials* **2017**, 5(19), 1700416

Acknowledgements. This work is supported by the Ministry of Science and Higher Education of Russia (project No. 075-15-2019-1896).

BIOLOGICAL ACTIVITY OF PQQ-CERIUM OXIDE NANOCOMPOSITE IN MENADIONE INDUCED  
OXIDATIVE STRESS *IN VITRO*

*Anikanova V.I.*<sup>1</sup>, *Popov A.L.*<sup>2</sup>, *Shcherbakov A.B.*<sup>3</sup>, *Ivanov V.K.*<sup>4</sup>

<sup>1</sup>Moscow state university, Moscow, Russia

<sup>2</sup>Institute of Theoretical and Experimental Biophysics of the Russian Academy of Sciences, Pushchino, Russia

<sup>3</sup>Zabolotny Institute of Microbiology and Virology, National Academy of Sciences of Ukraine,  
Kyiv, Ukraine

<sup>4</sup>Kurnakov Institute of General and Inorganic Chemistry of the Russian Academy of Sciences  
Student

[anikanova.victoria@gmail.com](mailto:anikanova.victoria@gmail.com)

Oxidative stress causes many diseases such as neurodegenerative, vascular and oncology. Antioxidant treatments is one of the common techniques to prevent oxidative stress in cell. However, the main problem of currently used antioxidant substances is their low efficiency or high toxicity in the concentrations which are necessary for therapeutic effect. Therefore, searching for more effective antioxidants is an actual task.

Here we report about new cerium-based nanocomposite which provide unique redox-activity. We have synthesized pyrroloquinoline quinone (PQQ) - cerium oxide nanocomposite and performed comprehensive analysis of its bioactivity *in vitro*. Cerium oxide nanoparticles has enzyme-like activity such as SOD, catalase, peroxidase, phosphatase and other [1]. Moreover, PQQ is characterized by antioxidant activity and has a significant effect to mitochondria, which is the main compartment of reactive oxygen species (ROS) formation [2]. The combination of these two substances in a single nanocomposite can provide their synergistic therapeutic effect in inhibiting oxidative stress.

We performed comprehensive analysis of PQQ-CeO<sub>2</sub> nanocomposite's properties which demonstrated its ultra-small (5-7 nm) size with negative  $\zeta$ -potential (-76 mV) and high colloidal stability. In addition, we investigated its cytotoxicity on human mesenchymal stem cell (MSC) culture including cell viability, mitochondrial membrane potential and ROS production. Moreover, we studied the biological activity of PQQ-CeO<sub>2</sub> in menadione induced oxidative stress. Our results showed that low concentrations of nanocomposite (0.1-10  $\mu$ M) are non-toxic for MSC, while high concentrations (20-100  $\mu$ M) decrease cell viability after 72 hours incubation. Furthermore, analysis of PQQ-CeO<sub>2</sub> biological activity confirmed that 2  $\mu$ M of nanocomposite reduces the ROS level, maintaining the high level of mitochondrial membrane potential comparable to the control groups.

Thus, according to our results, the PQQ-CeO<sub>2</sub> nanocomposite can be considered as a promising antioxidant agent in therapy of diseases induced by oxidative stress. Future research can conclude the study of the nanocomposite biological effect on cancer cells.

#### References

- [1] Popov A.L., et al. *Nanosystems: Physics, Chemistry, Mathematics*. **2017**, 8 (6), 760-781  
[2] Akagawa M., et al. *Bioscience, Biotechnology, and Biochemistry*. **2016**, 80(1), 13-22

Acknowledgements. This work was supported by the Russian Science Foundation (project No 20-74-00086)



# SYNTHESIS AND PROPERTIES OF HOLLOW IRON POWDERS OBTAINED VIA ULTRASONIC SPRAY-PYROLYSIS TECHNIQUE

*Artemova A.V.<sup>1</sup>, Maklakov S.S.<sup>1</sup>, Shiryayev A.O.<sup>1</sup>, Osipov A.V.<sup>1</sup>, Naboko A.S.<sup>1</sup>, Petrov D.A.<sup>1</sup>, Dolmatov A.V.<sup>2</sup>*

<sup>1</sup>Institute for Theoretical and Applied Electromagnetics RAS, Moscow, Russia

<sup>2</sup>Moscow Institute of Physics and Technology (National research University), Dolgoprudny, Russia  
Post-graduate student

[avometras@gmail.com](mailto:avometras@gmail.com)

The work describes a two-step synthesis of hollow particles of iron coated with thin shell SiO<sub>2</sub>. It is shown that variations in the spray-pyrolysis conditions give spherical particles that are different in diameter. Static and dynamic magnetic properties were measured and analyzed in terms of the mean size and geometry of the hollow particles. Prepared ferromagnetic powders with SiO<sub>2</sub> shells can be applied for inductors and electromagnetic interference shielding designs.

Experimental examination of microwave permeability of ferromagnetic powders with particles of different geometry is an actual fundamental problem.

The iron powder was obtained starting from Fe(NO<sub>3</sub>)<sub>3</sub> solution in water with a concentration of 10 and 20 wt. %. Two methods were combined: ultrasonic spray pyrolysis and reduction in hydrogen flow. Here and after, samples obtained from the 10 % solution were designated as F1, and samples obtained from the 20 % solution were designated as F2. Both samples consist of spherical hollow particles with a thickness of a wall of nearly 100 nm and an average size of 0.7 (F1) и 2 (F2) μm. According to the X-ray diffraction, the powders consist mainly of α-Fe with impurity of Fe<sub>3</sub>O<sub>4</sub>.

To prevent electrical interparticle contacts, F1 and F2 powders were covered with a protective SiO<sub>2</sub> shell [1, 2]. According to electron microscopy data, the shell thickness was estimated at 100 nm. At the same time, the proportion of SiO<sub>2</sub> in such a powder can reach 50 vol.%, due to individual dielectric particles.

Experimental measurements of the Curie temperature were carried out using the thermal analysis device Netzsch STA 449 F3. The measurements were performed in Ar flow: samples were heated to 1000 °C at a rate of 10 °C/min. To measure the Curie temperature, external magnets provided a magnetic field where the sample was located. The Curie temperature was estimated as a sharp mass change that was not accompanied by changes in the DCS signal. The Curie temperature of the samples was 767 °C, which is 3 °C lower than the tabular value for iron. As it is known from the literature, the Curie temperature for ferromagnets decreases with a decrease in particle size. With an average crystallite size of 30 nm in the studied powder, the difference in the measured parameter fits into the expected value. The resulting powders show no melting or sintering up to 1000 °C.

The poured bulk density of the powders was 6.1 (F1) and 6.7 (F2) g/cm<sup>3</sup>, which was 22 – 14 % lower than the measured poured bulk density for commercially available carbonyl iron. The appearance of the SiO<sub>2</sub> shell decreases the density of the powder to 3.5 g/cm<sup>3</sup> due to a significant proportion of SiO<sub>2</sub>.

The saturation magnetization of the obtained materials, F1 and F2, was 184 and ~100 emu/g, respectively, and the coercive force was 157 and ~200 Oe. The deposition of a dielectric SiO<sub>2</sub> coating reduces the saturation magnetization by about 15 %. The powder can be subjected to cold-pressing, and the discs for testing with a vibrating magnetometer were pressed without a binder.

The complex permittivity and permeability were measured using the Nicholson-Ross-Weir method [1, 2] in an air coaxial line. For measurements in the frequency range 0.1 – 20 GHz, composites with a paraffin wax matrix with a fraction of a filler of 66 wt.% were prepared. The microwave permeability of sample F1 is similar to the properties of commercial carbonyl iron, while sample F2 showed a single maximum of magnetic losses.

Further investigation of magnetic powders with hollow particles of a different size or chemical composition may provide experimental data for separating the contributions of various physical phenomena to the microwave magnetic permeability of composite materials.

## References

- [1] Kosevich A. V. (Artemova A.V.) et al. *Coatings* **2020**, 10, 10, 995
- [2] Maklakov S. S. et al. *Journal of Alloys and Compounds* **2017**, 706, 267-273

Acknowledgements. The reported study was funded by RFBR and NSFC according to the research project No. 20-52-53020.

# ADVANCES IN REGENERATIVE MEDICINE AND TISSUE ENGINEERING: INNOVATION AND TRANSFORMATION OF MEDICINE

*Baniya N.<sup>1</sup>*

<sup>1</sup>Zhejiang University of Technology, Hangzhou, Zhejiang, P.R. China

Student

[nishchalbaniya@gmail.com](mailto:nishchalbaniya@gmail.com)

Regenerative medication (RM) is another approach to fix patients other than conventional medication and medical procedure. RM incorporates items from all the mainstays of medical care, for example drugs, biopharmaceuticals, clinical gadgets and cell treatments, to convey clinical results. All around the world, the cell treatment industry is simply developing, and keeping in mind that RM additionally draws upon non-cell-based medicines, undifferentiated organism based items and administrations have probably the most captivating chances and expectations with respect to beforehand serious sicknesses. In this exposition, the emphasis is on undeveloped cell based items and administrations. The fundamental examination question is the way scholastic exploration based advancements happen and can be moved to new organizations and treatments in the RM area. Hypothetically, this exposition expands on advancement frameworks, development related clinical innovation writing, and ability alliance hypothesis. Clinical innovation writing distinguishes parts of clinical innovation advancement development and how its components are conceptualized inside wellbeing advancement frameworks. Skill alliance hypothesis gives a decent clarification to how business develops and what skills are required. This thesis followed a valuable exploration approach and a solitary contextual analysis technique. The observational information comprises of 24 interviews and significant auxiliary information (reports, distributions, measurements, and so on) Utilizing observational information and foundation writing, a development was created so as to clarify how development happens at the framework level and to distinguish the entertainers that are included.

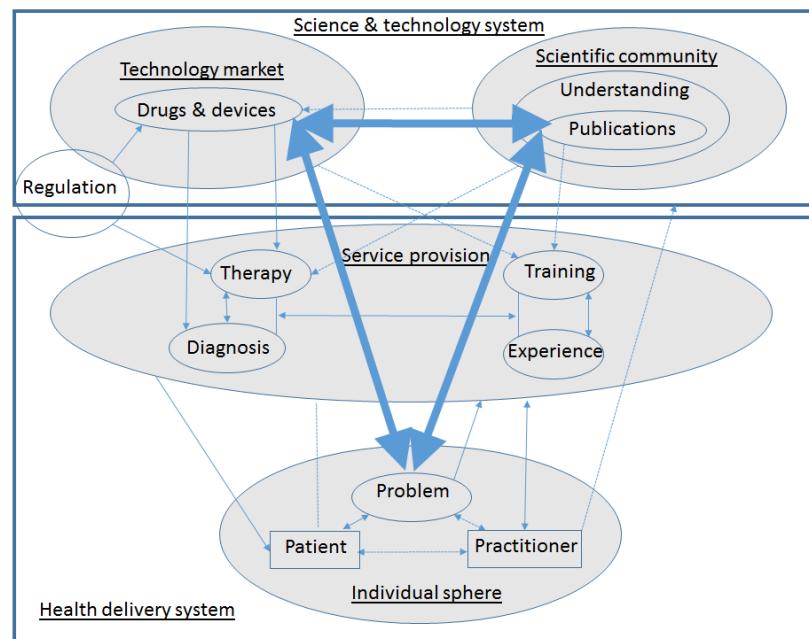


Figure: Health innovation system adapted from Consoli and Mina

## References

- [1] Autio, E. (1998). Evaluation of RTD in regional systems of innovation. *European planning studies*, 6(2), 131-140.
- [2] Avnimelech, G. and Teubal, M. (2006). Creating venture capital industries that coevolve with high tech: Insights from and extended industry life cycle perspective of the Israeli experience. *Research Policy*, 35, 1477-1498.
- [3] Avnimelech, G. and Teubal, M. (2008). Evolutionary targeting. *Journal of Evolutionary Economics*, 18, 151-166

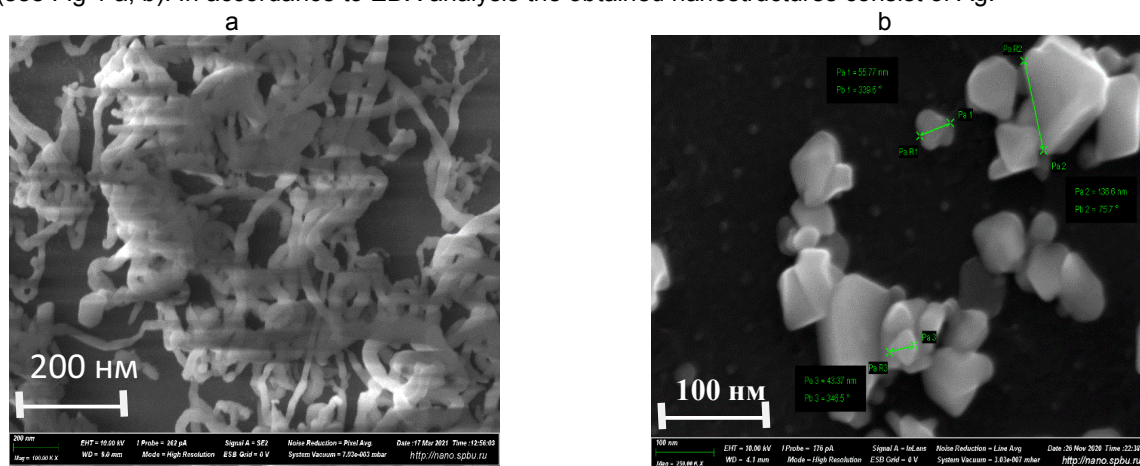
# LASER-DEPOSITED NANOFIBERS AS SERS-ACTIVE TAGS

*Belhadi A., Vasileva A., Pankin D., Manshina A.*

Saint Petersburg State University, Saint Petersburg, Russia  
belhadi.ahmed99@gmail.com

Surface-enhanced Raman scattering (SERS) has become one of the effective emerging spectroscopic tools to explore different biological entities owing to its excellent sensitivity and molecular detection competences [1]. It is reported that in SERS the intensity of the Raman signal that comes from a molecule gets enhancement by many orders of magnitude when the molecules adsorbed to the surface of metallic nanostructures [2]. The mechanism of SERS mainly involves the enhancement of electromagnetic field and chemical signals associated with the molecules [3]. However, the efficiency of SERS enhancement depends on properties of the metal nanostructures on which the molecules of analyte are absorbed. That is why synthesis of SERS active substrates is always an important scientific and practical task.

Here, we present a laser-induced deposition (LID) approach allowing for single-step surface decoration with nanostructures of controllable composition, morphology, and spatial distribution. The formation of Ag nanoparticles on a substrate surface was successfully demonstrated as a result of the LID process from commercially available precursors [4]. Further research in this direction allowed us to develop the LID process and to extend the variants of morphology of the deposited nanostructures. Here we present investigation of the effect of experimental parameters on the deposits' morphology. In the current research the silver benzoate hydrate was used as precursor for LID; as solvent we used water and isopropanol. LID process was carried out at varied laser wavelengths (374, 448 nm), laser deposition time (10, 20, 30,60 mins). It was found the LID process allows formation not only nanoparticles but also nanofibers characterizing high specific surface area (see Fig 1 a, b). In accordance to EDX analysis the obtained nanostructures consist of Ag.



**Figure 1. a** – nanofibers obtained as a result of LID from water solution of silver benzoate hydrate under laser irradiation (374nm) (40 min) **b** – nanoparticle obtained as a result of LID from water solution of silver benzoate hydrate under laser irradiation (448nm) (40 min)

Deposited nanostructures – nanoparticles and nanofibers – were studied as SERS-active tags for detection of different analytes, including dangerous organic pollutants.

## References

- [1] Streltsov, S., Oleinikov, V., Ermishov, M., Mochalov, K., Sukhanova, A., Nechipurenko, Y. Rachofsky, S., Zhuze, A., Pluot, M., Nabiev, I. **2003**. Biopolymers 72, p. 442 (b) Podstawka, E., Ozaki, Y., Proniewicz, L. M. 220. Appl. Spectrosc. 58, p. 570.
- [2] Moskovits, M. 1985. Rev. Mod. Phys. 57, p. 783
- [3] Pavan Kumar, G. V., Shruthi, S., Vibha, B., Ashok Reddy, B. A., Tapas K. Kundu, and Chandrabhas Narayana, 2007. J. Phys. Chem. C 111, p. 4388
- [4] Daria Mamonova, Anna Vasileva, et al. 2021, Materials, 14(1), 10

Acknowledgements. This work was supported by Russian Foundation for Basic Research (project No 20-58-12015).

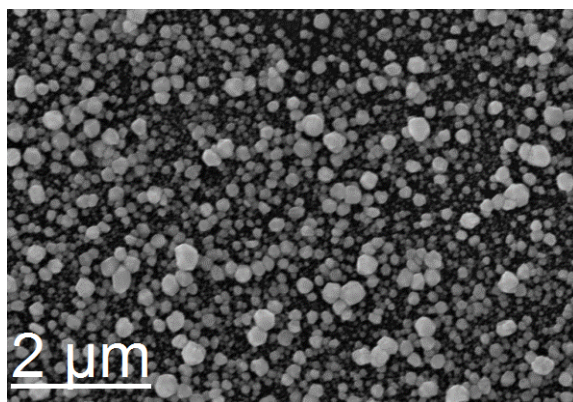
## LASER DEPOSITED SILVER NANOPARTICLES FOR FLUORESCENCE ENHANCEMENT

*Bikbaeva G.I., Vasileva A.A., Mamonova D.V., Kolesnikov I.E., Kalinichev A.A., Manshina A.A*

Saint Petersburg State University, Saint Petersburg, Russia

[BikbaevaGI@yandex.ru](mailto:BikbaevaGI@yandex.ru)

Nanostructured materials occupy a leading place in modern materials science due to their unique properties. Local enhancement of electromagnetic fields near dielectric and metallic surfaces is usually associated with the excitation of surface plasmons. This phenomenon finds applications in enhancing optical spectroscopic signals, nonlinear optical processes, biosensing, imaging contrast and superresolution, photovoltaics response, local heating, photocatalysis, and enhanced efficiency of optoelectronic devices [1-2]. Ultrahigh enhancement of optical fields allows creation of new devices, new methodologies for ultrahigh sensing for environmental and medical applications.



**Figure 1.** SEM image of Ag NPs.

The aim of this study was to obtain uniformly distributed Ag nanoparticles on the substrate surface, to study the optical properties of the resulting nanostructures, as well as to demonstrate the amplification of the fluorescence signal of various analytes (such as R6G, and analytes significant for biomedicine). Scanning electron microscopy showed a regular spatial distribution of Ag nanoparticles obtained by Laser induced deposition from solution of commercially available  $C_7H_7AgO_3$  metal organic complex (Fig.1). It was established that the morphology of nanoparticles can be controlled by varying the duration, the power of the laser radiation, the type of solvent and the concentration of the complex in the solvent. Fluorescence studies for chosen analytes have shown a signal gain of 3 times for the deposited NPs.

Acknowledgements. This work was supported by RFBR-DFG (RFBR project № 20-58-12015). Optical measurements were carried out using the equipment of the resource center "Optical and laser methods for studying matter", morphology and composition studied at the Interdisciplinary Resource Center in the direction "Nanotechnology" SPBU.

### References

- [1] Jiajia Wang, Zhenhong Jia, Changwu Lv, Yanyu Li// CHINESE OPTICS LETTERS (2017);
- [2] Daria V. Mamonova ,Anna A. Vasileva, Yuri V. Petrov ,Denis V. Danilov ,Ilya E. Kolesnikov, Alexey A. Kalinichev ,Julien Bachmann, Alina A. Manshina // Materials **2021**, 14, 10.

STUDY OF THE SYNTHESIS OF CERAMIC MATERIALS BASED ON BARIUM HEXAFERRITE,  
SUBSTITUTED WITH ALUMINUM, WITH A VIEW TO IMPROVING  
THE PHYSICOCHEMICAL PROPERTIES

*Bogatyreva K.A., Zhivulin V.E., Vinnik D.A., Pavlova K.P.*

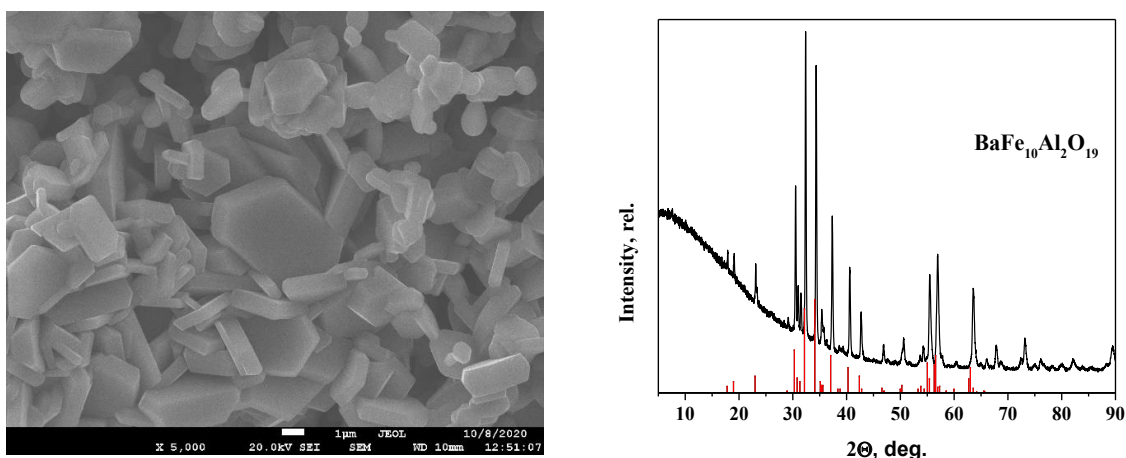
Student

South Ural State University, Chelyabinsk, Russia

[bogatyreva2000@bk.ru](mailto:bogatyreva2000@bk.ru)

The aim of the study was to obtain barium hexaferrite substituted with aluminum BaFe<sub>10</sub>Al<sub>2</sub>O<sub>19</sub>. There are various ways to synthesize ferrites, the most common simple and straightforward way to use a synthesizer [1-2]. The initial components for preparing the samples were powders of Fe<sub>2</sub>O<sub>3</sub> (72.7 wt%), Al<sub>2</sub>O<sub>3</sub> (9.3 wt%), and BaCO<sub>3</sub> (18.9 wt%). The starting materials were measured in specified stoichiometric ratios, mixed and ground for 30 minutes in an agate mortar. After grinding, the resulting mixture was compressed into a tablet. The pressing was carried out in a metal mold with a diameter of 20 mm using a laboratory hydraulic press. The resulting tablet was placed on a platinum sheet in a high-temperature electric furnace and sintered at a temperature of 1380 °C for 5 hours.

X-ray phase analysis and electron microscopy were used as research methods. The obtained sample was examined on an Optima IV powder diffractometer of the Rigaku model (Cu radiation). The morphological features of the surface (Figure 1 a) and the elemental composition (Table 1) were studied using a JEOL scanning electron microscope, model JSM7001F, equipped with an INCAX-max 80 X-ray energy dispersive spectrometer (Oxford Instruments). X-ray diffraction patterns were recorded in the 2θ angle range from 5 to 90 degrees. with a step of 0.02 deg. and a shooting speed of 5 deg / min (Figure 1 b).



**Figure 1:** a) Structure of barium hexaferrite BaFe<sub>10</sub>Al<sub>2</sub>O<sub>19</sub>, magnification x5000; b) Diffraction pattern of the BaFe<sub>10</sub>Al<sub>2</sub>O<sub>19</sub> sample

№	Elemental composition, at.%,				Prescribed formula	The actual formula
	O	Al	Fe	Ba		
1	56.15	5.94	34.32	3.60	BaFe <sub>10</sub> Al <sub>2</sub> O <sub>19</sub>	BaFe <sub>10.56</sub> Al <sub>1.44</sub> O <sub>19</sub>
2	48.72	5.14	42.09	4.06		
3	49.45	5.06	41.31	4.18		
4	49.11	5.29	41.46	4.14		

**Table 1.** Results of elemental analysis of the BaFe<sub>10</sub>Al<sub>2</sub>O<sub>19</sub> sample

A sample of ceramic material BaFe<sub>10</sub>Al<sub>2</sub>O<sub>19</sub> was obtained by solid-phase synthesis at a temperature of 1380 °C. Based on the data obtained, it can be concluded that the temperature of 1380 °C is optimal for obtaining the synthesis of the sample. Comparing the literature data [3] with the obtained X-ray diffraction pattern, we can conclude that the sample is monophasic. Obtaining monophasic samples of barium hexaferrite substituted with aluminum will allow further research aimed at modifying the base matrix.

**References**

- [1] Vinnik D., Zhivulin V., *Nanomaterials* **2019**, 559.
- [2] El Shater R.E., El-Ghazzawy E.H., *J. Alloys Compd*, **2018**, 327-334
- [3] X. Obradors, A. Collomb, *Journal of Solid State Chemistry*, **1985**, 171-181

Acknowledgements. This work was supported by the reported study was funded by RFBR (project number 20-38-70057)

<sup>1</sup>South Ural State University, Chelyabinsk, Russia

Student

[a.boldin.science@gmail.com](mailto:a.boldin.science@gmail.com)

Ferrites due to low specific thermal conductivity and high magnetic permeability are promising materials for creating elements of high-frequency electronics devices, such as phase shifters, attenuators (valves), circulators.

In connection with the development, in recent years, of communications and high-speed wireless Internet, the need for an elementary microwave electronics base has increased. Consequently, the need for new functional materials has increased.

Changing the chemical composition of a substance without changing its crystal structure makes it possible to smoothly adjust the properties of the material for a specific task. Studying the possibility of obtaining materials with controlled properties is an urgent task of modern materials science.

The purpose of the presented work is to develop an optimal technology for producing hexagonal ferrite of the M-type composition  $Ba_xSr_{1-x}Fe_{12}O_{19}$  and to study its properties. As a method of producing ceramics, solid-phase synthesis was chosen. Solid phase synthesis is the most economical and convenient method of ferrite synthesis, providing maximum quantitative yield of the final product.

The starting components for preparing the samples consisted of iron oxide ( $Fe_2O_3$ ) and barium ( $BaCO_3$ ) and strontium ( $SrCO_3$ ) carbonates. All reagents used were qualified not lower than analytical grade. The starting components were stoichiometrically measured, mixed and rubbed in agate mortar. The resulting mixture was compressed into 25 mm diameter tablets using a metal mold. The pressing force was 1.5 tons per  $cm^2$ . The resulting tablets were placed on a platinum substrate and sintered in a high temperature oven at 1350°C. Thus, 6 samples of compositions were prepared:  $BaFe_{12}O_{19}$ ,  $Ba_{0.2}Sr_{0.8}Fe_{12}O_{19}$ ,  $Ba_{0.3}Sr_{0.7}Fe_{12}O_{19}$ ,  $Ba_{0.5}Sr_{0.5}Fe_{12}O_{19}$ ,  $Ba_{0.8}Sr_{0.2}Fe_{12}O_{19}$ ,  $SrFe_{12}O_{19}$ .

X-ray and XRC analysis of the synthesized samples were performed using a Rigaku Ultima IV powder diffractometer using  $Cu\alpha$  radiation. Surface morphology and elemental composition of samples were studied using a Jeol JSM 7001F electron microscope equipped with Oxford INCA X-max80 X-ray fluorescence spectrometer. According to X-ray phase and X-ray structure analysis, all the test samples are single-phase and have the structure of M-type hexagonal ferrite (Fig. 1).

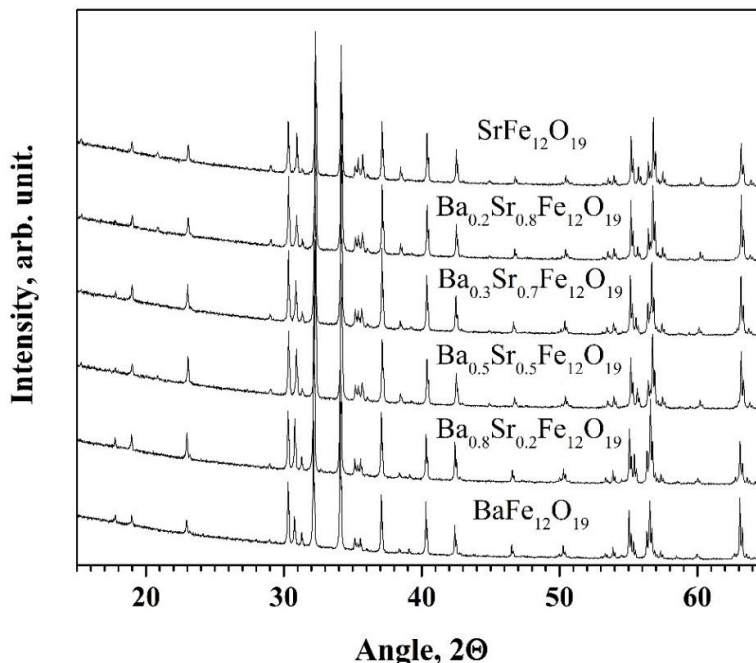


Fig.1. The X-Ray powder diffraction patterns

As a result of the work done, it was determined that the optimal sintering temperature of the ferrite ceramics of the composition  $Ba_xSr_{1-x}Fe_{12}O_{19}$  is 1350°C. Duration of isothermal holding is 5 hours.

Additionally, the project was supported President's grants for young doctors of science (MD-5612.2021.4).

# CHROMATOGRAPHIC AND MASS SPECTROMETRIC DETERMINATION OF PRODUCTS IN THE CATALYTIC TRANSFORMATION OF ETHANOL

*Brovko R.V., Doluda V.Yu., Nikoshvili L.Zh., Sulman M.G.*

Tver State Technical University, Tver, Russia  
PhD student

[RomanVictorovich69@mail.ru](mailto:RomanVictorovich69@mail.ru)

The problem of depletion of traditional hydrocarbon reserves is important for industry and requires the development of a synthetic hydrocarbon technology based on renewable materials or wastes. Ethanol can be considered as platform molecular. It can be used directly as fuel or for production ethylene, propylene, other different hydrocarbons including aromatic hydrocarbons, acetic acid, acetaldehyde, butanol, liquid C<sub>5</sub>-C<sub>10</sub> gasoline fractions, and heavy C<sub>10+</sub> hydrocarbons. For a complete understanding of the process, a serious quantitative and qualitative analysis of the resulting reaction products is required.

Quantitative analysis was performed on a gas chromatograph. Gas phase analysis was performed using Crystal 2000M, equipped with an automatic gas valve for sampling, a thermal conductivity detector and a flame ionization detector. Gas analysis was carried out using a Hayesep Q80 / 100 packed column, l = 3m, d = 2 mm, T<sub>max</sub> = 275 °C. Liquid phase analysis was performed using Crystall 2000 equipped with a flame ionization detector. The samples were analyzed using a ZB-1 capillary column, l = 30m, d = 0.32 mm, T<sub>max</sub> = 310 °C. Evaporator temperature 300°C, temperature of flame ionization detector and thermal conductivity detector 250°C, determination of hydrocarbons according to GOST R 52714-2007 [1].

Qualitative chromatomass spectrometric analysis was performed using Shimadzu GS-MS-2010, chromatograph oven temperature was 50 °C, evaporator temperature was 300 °C, pressure was 182.9 kPa, total flow was 81.5 ml / min, gas flow through the column was 1 ml / min, linear velocity was 19.9 cm / s, purge flow was 5 ml / min, division ratio was 1, temperature program was 50 °C hold 10 minutes than rise to 310 °C at 10 °C / min, exposure 15 minutes. Ion source temperature was 260 °C, interface temperature was 280 °C, analysis duration was 45 min.

Using GSMS the following hydrocarbons were determined: benzene, toluene; ethylbenzene; 1-methylethylbenzene; propylbenzene; 1,2,3-trimethylbenzene; allylbenzene; 1,2-diethylbenzene; 2-phenylbutane; 2-ethyl-1,4-dimethylbenzene; o-Cymene; 1-methyl-2-(1-methyl-2-propenyl)-benzene; 1,2,3,4-tetramethyl-5-methylenebenzene; o-xylene; 1,3-diethyl-5-methyltoluene; p-isobutyl; 2,4-diethyl-1-methylbenzene; naphthalene; (2-methyl-1-butenyl)-benzene; 1-methylnaphthalene; 2-methylnaphthalene; alfa-ethylnaphthalene; 2,3-dimethylnaphthalene; 1-propylnaphthalene; 2-isopropylnaphthalene; 1,4,6-trimethylnaphthalene; 1,4,5-trimethylnaphthalene. Application of Crystal 2000M gas chromatograph equipped with flame ionization detector allowed to determined concentrations of identified substances.

## References

[1] Doluda V.Yu. Lakina N.V., Brovko R.V., Mikhailov S.P. *Scientific and technical bulletin of the Volga region*. **2018**, 12, 35-38.

Acknowledgements. This work was supported by the Russian Foundation for Basic Research (project No 20-08-00191) and the Russian Science Foundation (project No 20-19-00386).

# THE EFFECT OF GLUCOSE-DERIVED CARBON NANODOTS PREPARATION CONDITIONS ON THEIR PROPERTIES

*Bugerya A.A., Karpushkin E.A.*

Lomonosov Moscow State University, Moscow, Russia  
Student  
bugerya.alexei@yandex.ru

Carbon nanodots (C-dots) are carbonaceous nanoparticles bearing hydrophilic functional groups at the surface. Since their discovery in 2006, numerous examples of C-dots preparation from various sources have been shown, and peculiar applications in sensing, bioimaging, and catalysis have been demonstrated.

Since C-dots can be prepared from a variety of sources (including natural mixtures of poorly predictable composition) using very simple, often home-made equipment, it is not easy to compare the data on C-dots preparation and properties reported by different scientific groups. Herein, we performed a comprehensive study of preparation of C-dots from glucose under controlled conditions in order to reliably elucidate the synthetic parameters which are essential to control the synthesis of C-dots.

We synthesized the C-dots via hydrothermal treatment of aqueous solutions of glucose. The varied parameters were initial concentration of glucose and pH of the solution, temperature and duration of hydrothermal treatment. The experiments were arranged in a full factorial design scheme, and each combination of the synthesis conditions was probed in triplicate. To quantitatively assess the outcome of the synthesis, we measured pH of the prepared product, determined the product yield by means of gravimetry, and recorded the optical absorption and emission spectra. The obtained data were analyzed in the frame of ANOVA (analysis of variance) of the linear model procedure to identify the variables which gave statistically significant impact on the synthesis outcome.

As an example, the analysis of the effects of the synthesis parameters on the yield of the C-dots revealed very high statistical significance of the effects of synthesis duration, concentration, and temperature ( $p < 10^{-6}$ ), high significance of the starting pH effect ( $p < 0.05$ ), and high significance of certain paired interactions of the factors (concentration–duration, concentration–temperature, duration–temperature,  $p < 0.05$ ). ANOVA results using other output variables (pH of the product, optical properties) gave similar results.

Analysis of the linear model including the active factors revealed that the main factors (temperature, duration, and concentration) were positively related to the C-dots yield, whereas all pairwise interactions revealed the negative relationship (for example, shorter duration is advantageous at higher temperature, lower temperature is advantageous at higher concentration, and so on). Therefore, maximization of the yield in the considered system cannot be achieved merely by increasing temperature, duration, and concentration simultaneously. Instead, accurate analysis of the response surface is required.

Acknowledgements. This work was supported by the Russian Foundation for Basic Research (project No 20-03-00692).



# TRIGGERED RELEASE OF TRITC-DEXTRAN FROM POLYELECTROLYTE MAGNETIC MICROCAPSULES UPON APPLICATION OF A LOW FREQUENCY MAGNETIC FIELD

*Burmistrov I.A.*<sup>1</sup>, *Mikheev A.V.*<sup>1,2</sup>, *Veselov M.M.*<sup>2</sup>, *Borodina T.N.*<sup>1</sup>, *Klyachko N.L.*<sup>2</sup>,  
*Bukreeva T.V.*<sup>1,3</sup>, *Trushina D.B.*<sup>1,4</sup>

<sup>1</sup> Shubnikov Institute of Crystallography of Federal Scientific Research Centre "Crystallography and Photonics" of Russian Academy of Sciences, Moscow, Russia

<sup>2</sup> Lomonosov Moscow State University, Moscow, Russia

<sup>3</sup> National Research Centre "Kurchatov Institute", Moscow, Russia

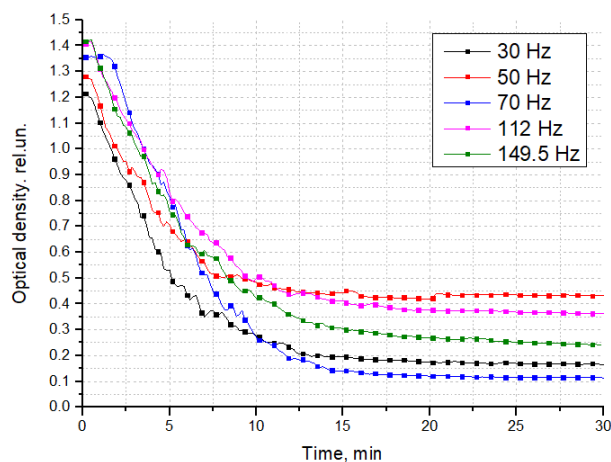
<sup>4</sup> Institute of Molecular Medicine Sechenov First Moscow State Medical University, Moscow, Russia

Ph.D. Student

[burmiivan@gmail.com](mailto:burmiivan@gmail.com)

Nanocarriers providing control of drug release contribute to reducing toxicity and improving therapeutic efficacy of a drug. Polyelectrolyte microcapsules are one of the promising carriers for encapsulation of different bioactive molecules [1]. The versatility of microcapsules is also determined by a wide range of their modification possibilities that enable additional functionalities for controlled release using ultrasound, laser irradiation, magnetic field, etc. Application of a non-heating low frequency magnetic field for controlled release is beneficial in terms of high locality, safety, and efficient tissue penetration, which makes this method suitable for *in vivo* use [2].

In this work, we study the influence of a low frequency magnetic field (30 – 150 Hz, 100 mT) on the release of TRITC (tetramethylrhodamine isothiocyanate) labeled dextran (65-85 kDa) from the Poly(allylamine hydrochloride) (PAH) / Poly(styrene sulfonate) (PSS) multilayer capsules modified by magnetite nanoparticles (MNP). Magnetite nanoparticles were synthesized by the Massart method. The capsules were obtained by the Layer-by-Layer method on the vaterite sacrificial templates, they had the following structure: PAH/PSS/PAH/MNP/PSS/PAH/PSS. The capsules and magnetic nanoparticles are characterized using a scanning electron microscope (Jeol JSM-7401F), transmission electron microscope (FEI Osiris), dynamic light scattering (Zetasizer ZS, Malvern), and magnetometer (EG&G PARC model 155). To monitor the changes in the release of TRITC-dextran under the influence of the low frequency magnetic field we measure the time dependence of optical density of the suspension of the polyelectrolyte microcapsules upon irradiation with a magnetic field. The optical density at the 521 nm upon 50 Hz irradiation is higher than upon irradiation with other frequencies (Fig.1). This result demonstrates the ability of low frequency magnetic field to promote the release of high molecular weight compounds from the multilayer microcapsules. The determined frequency most likely corresponds to the resonant frequency of mechanical vibrations of magnetic nanoparticles in the polyelectrolyte shell.



**Figure 1.** The time dependences of optical density at the 521 nm for different frequency.

## References

- [1] Lengyel, M.; Kállai-Szabó, N.; Antal, V.; Laki, A.J.; Antal, I. *Microparticles*, *Sci. Pharm.* 2019, 87, 20.
- [2] Luo D., Poston R.N., Gould D.J., Sukhorukov G.B., *Materials Science and Engineering: C*, 2019, 94, 647-655,

**Acknowledgements.** The authors of the work are grateful to Artemov V.V. for the study of the samples by scanning electron microscopy and D.N. Khmelenin for the study of samples by transmission electron microscopy. This work was performed using the equipment of the Shared Research Center FSRC "Crystallography and Photonics" RAS and was supported by the Ministry of Science and Higher Education of the Russian Federation (project RFMEFI62119X0035) and by the grant of the President of the Russian Federation (MK-1109.2021.1.3).

# INVESTIGATION OF THE DECOMPOSITION PRODUCTS AND KINETICS OF DEGRADATION OF ZIF-8 IN LACTIC ACID

*Butonova S.A., Morozov M.I., Vinogradov A.V.*

ITMO University, Saint Petersburg, Russia  
Student

[butonova@scamt-itmo.ru](mailto:butonova@scamt-itmo.ru)

Chemotherapy is commonly a part of tumor and metastases treatment. However, the main problem of it is in the indiscriminate nature of anticancer drugs and their poor access to tumors. Moreover, chemotherapy requires a large dose of anticancer drugs and toxic for both tumor and healthy normal cells in its immediate vicinity and in some cases lead to severe unintended and undesirable side effects. An approach of targeting drug delivery was proposed to achieve high selectivity, thereby reducing the side effects and toxicity of cancer drugs to normal healthy cells [1].

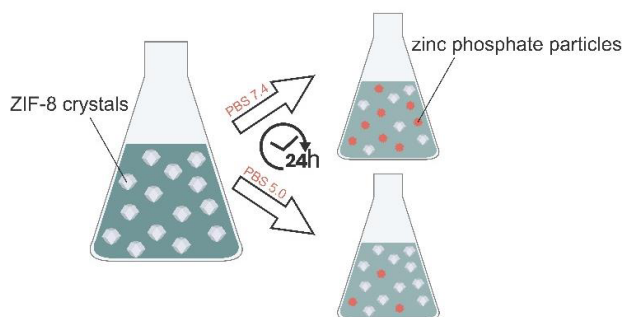
Metal-organic frameworks (MOFs) are one of the most promising carriers for targeted drug delivery systems. Due to their flexible structure with a combination of unique properties such as crystallinity, porosity, and the presence of strong metal-ligand interactions, they provide a good prospect for targeted drug delivery systems 2. Among MOFs, ZIF-8 which consists of  $(\text{Zn}(\text{mim})_2)$ , mim = 2-methylimidazolate) is considered one of the most promising substances for drug delivery systems, since it can degrade in an acidic media [2].

Because of a "Warburg effect", a large amount of lactate secreted by the tumor cells leads to the acidification of the extracellular environment in a tumor [3]. Therefore, during the research, lactic acid as the substance that acidified ZIF-8 particles has been chosen. Nevertheless, ZIF-8 can be destroyed not only in the presence of lactate but also in the presence of various ions [4]. In this work we focus on phosphorus ions because they include in PBS, which is a buffer solution to study the kinetics of the release of the encapsulated molecules in ZIF-8 in solutions with various pH [2]. So, the comparison of Hmim release in PBS and NaCl solutions will lead us to a better understanding of what is influenced on the decomposition rate of ZIF-8 to a greater extent: the influence of phosphate groups or pH of the solutions.

During the research, the synthesis method of ZIF-8 has been improved to obtain sodalite topology. Moreover, the degradation rate of ZIF-8 in PBS and NaCl solutions in the presence of cell cultures and without was calculated. Also, the study of the influence of the degradation products of ZIF-8 on cell cultures was performed to analyze their biocompatibility.

In conclusion, PBS buffer cannot be used as a buffer solution for study the kinetics of the release of the encapsulated molecules in ZIF-8 because of the influence of phosphate groups on the degradation of ZIF-8. Moreover, this project raises new questions about the application of ZIF-8 as a nanocarrier for drug delivery systems. In addition, this work provides prospects for future research:

- Stabilization of ZIF-8 to avoid degradation of ZIF-8 in human body.
- The effect on the degradation of ZIF-8 of various other biological liquids that may be present in



the human body.

**Figure 1.** Scheme of degradation ZIF-8 in PBS solution.

## References

- [1] S. Senapati, A. K. Mahanta, S. Kumar and P. Maiti, *Signal Transduct. Target. Ther.*, **2018**, 3, 1–19.
- [2] A. Sharsheeva, V. A. Iglin, P. V. Nesterov, O. A. Kuchur, E. Garifullina, E. Hey-Hawkins, S. A. Ulasevich, E. V. Skorb, A. V. Vinogradov and M. I. Morozov, *J. Mater. Chem. B*, **2019**, 7, 6810–6821.
- [3] A. Annibaldi and C. Widmann, *Curr. Opin. Clin. Nutr. Metab. Care*, **2010**, 13, 466–470.
- [4] H. Wang, M. Jian, Z. Qi, Y. Li, R. Liu, J. Qu and X. Zhang, *Microporous Mesoporous Mater.*, **2018**, 259, 171–177.

Acknowledgements. This work was supported by the Russian Science Foundation (Grant No. 19-19-00433).

# REVEALING THE COMPLEX REFRACTIVE INDEX OF NOVEL HYBRID CARBON FLAKES

Butt M.A.T<sup>1,2,3</sup>, Mamonova D.<sup>4</sup>, Manshina A.A.<sup>4</sup>, Leuchs G.<sup>1,2,3,4</sup> and Banzer P.<sup>1,2,3,5</sup>

<sup>1</sup>Max Planck Ins. for the Science of Light, 91058 Erlangen, Germany

<sup>2</sup>IOIP, University Erlangen-Nuremberg, 91058 Erlangen, Germany

<sup>3</sup>School of Advanced Optical Technologies, 91052 Erlangen, Germany

<sup>4</sup>Institute of Chemistry, SPBU, St. Petersburg, Russia

<sup>5</sup>Institute of Physics, Uni of Graz, Universitätsplatz 5, Graz, Austria

[muhammad-abdullah.butt@mpl.mpg.de](mailto:muhammad-abdullah.butt@mpl.mpg.de)

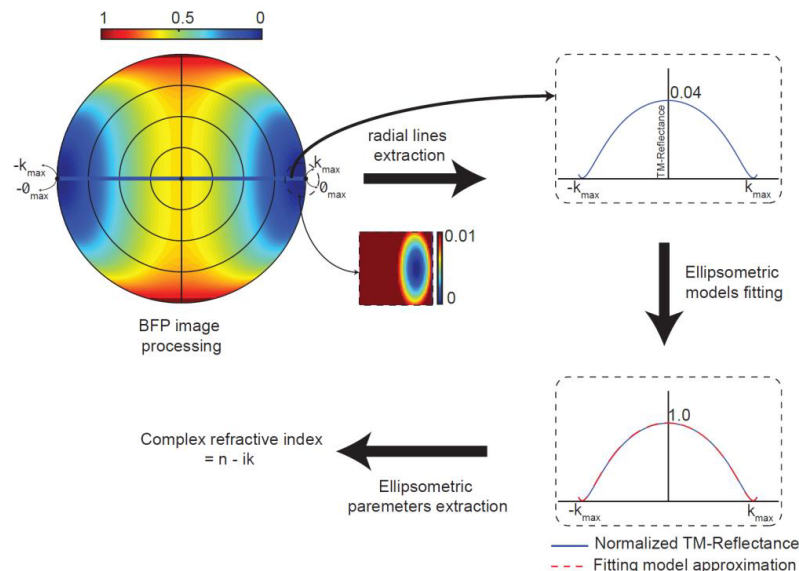
Recently, a series of studies revealed that with laser-induced deposition, a novel carbon allotrope can be fabricated [1-3], featuring an orthorhombic crystal lattice and lateral dimensions of few microns. The process involves photo-induced decomposition of metalorganic precursors resulting in carbon lattice also featuring intercalated metal nanoparticles. These hybrid flakes have already proven to exhibit interesting optical, structural and electronic properties, such as it shows a strong linear optical birefringence due to the carbon lattice [1, 2]. However, the small lateral dimensions of the flakes made it virtually impossible so far to retrieve the actual refractive indices of the material, preventing the formation of a more complete understanding of carbon flakes.

Here we now present a novel versatile method, which can be applied to measure the complex refractive index of micron-sized specimens accurately. This method is based on the illumination of a structure under study from a wide spectrum of angles simultaneously. By recording the reflected light in Fourier space, we can evaluate the reflected light in angularly resolved fashion. The sub-wavelength size of the focal illumination area makes it possible to investigate small (micron sized)specimens, while performing, the measurement in a single shot. To retrieve real and imaginary part of the refractive index, we utilize an easy-to-implement fitting algorithm based on generalized Fresnel coefficients. As a proof of concept, we show results for various materials, including dielectrics, absorbing materials, and uniaxial crystals. Furthermore, we also apply our technique to retrieve the complex refractive indices of the aforementioned orthorhombic hybrid carbon flakes. Our results highlight again the interesting optical properties of this exotic material. Our method paves the way for the convenient and straight-forward study of future material systems.

[1] M. A. Butt *et al.*, "Investigating the Optical Properties of a Laser Induced 3D Self-Assembled Carbon-Metal Hybrid Structure," *Small*, vol. 15, no. 18, p. e1900512, May 2019.

[2] M. A. Butt *et al.*, "Hybrid Orthorhombic Carbon Flakes Intercalated with Bimetallic Au-Ag Nanoclusters: Influence of Synthesis Parameters on Optical Properties," *Nanomaterials (Basel)*, vol. 10, no. 7, Jul 15 2020.

[3] A. Povolutckaia *et al.*, "Plasmonic carbon nanohybrids from laser-induced deposition: controlled synthesis and SERS properties," (in English), *Journal of Materials Science*, vol. 54, no. 11, pp. 8177-8186, Jun 2019.



A schematic of the numerical and experimental method used for calculation of complex refractive index based on multiple angles of incidence recorded in the back focal plane of a focusing lens. This method assists in retrieving a broad angular spectrum in single shot, hence reducing the time required for experimental measurements in conventional commercial systems.

# FORMATION FEATURES OF $\text{Sc}_{2-x}\text{Fe}_x\text{O}_3$ NANOCRYSTALS VIA GLYCINE-NITRATE COMBUSTION SYNTHESIS

*Chebanenko M.I.<sup>1,2</sup>, Popkov V.I.<sup>1</sup>*

<sup>1</sup>Ioffe Institute, Saint Petersburg, Russia

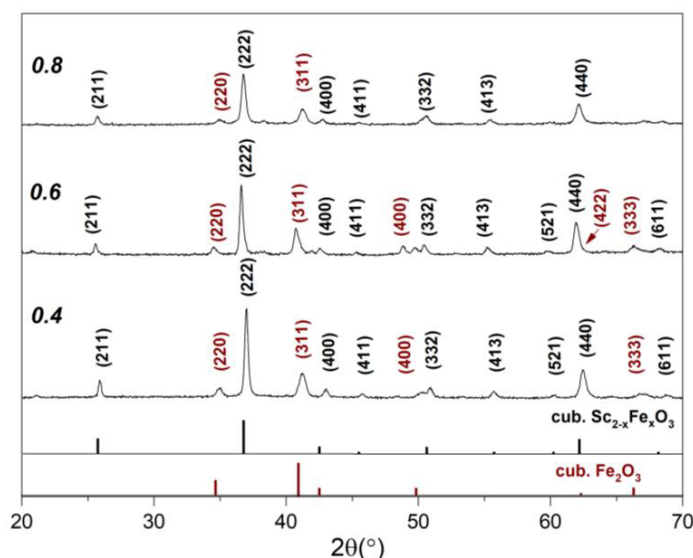
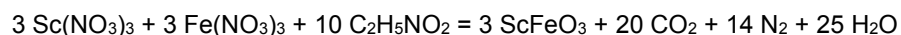
<sup>2</sup>Saint Petersburg State Institute of Technology, Saint Petersburg, Russia

Ph.D. Student

m\_chebanenko@list.ru

It is well known that scandium orthoferrite  $\text{ScFeO}_3$  crystallizes in 4 metastable structural forms (spinel, corundum, bixbite, and  $\text{YMnO}_3$ -type) as a result of using various synthesis techniques - solution-assisted methods, high-pressure synthesis, or thin-film processing. However, the features of  $\text{ScFeO}_3$  formation are still not clear enough to its real practical application. Therefore, this paper presents a comprehensive study of the Sc-Fe oxide synthesis in the nanocrystalline form via solution combustion to better understand the general patterns of its formation.

In this study nanoparticles of scandium/iron oxides were obtained by self-propagating glycine-nitrate combustion from aqueous solutions of stoichiometric amounts of  $\text{Fe}(\text{NO}_3)_3 \cdot 9\text{H}_2\text{O}$  and  $\text{Sc}(\text{NO}_3)_3 \cdot 4\text{H}_2\text{O}$  and glycine  $\text{C}_2\text{H}_5\text{NO}_2$  the amount of which was chosen according to glycine and nitrates ratio ( $0.2 \leq \text{G/N} \leq 1.4$ ). Then precursor solution was heated under magnetic stirring. When water was boiled away, the gel-like sample was obtained and heated up until self-ignition. The yield product was brown fluffy powder. The stoichiometric reaction corresponding to glycine-nitrate combustion with stoichiometric G/N ratio of 0.56 presented as follows:



**Figure 1.** PXRD pattern of  $\text{ScFeO}_3$ -based products synthesized via glycine nitrate combustion at different G/N

The resulting samples were examined by powder X-ray diffraction, Mössbauer spectroscopy, low-temperature nitrogen sorption-desorption, and helium pycnometry. It was found that at the ratios  $\text{G/N} = 0.4$ - $0.8$ , the cubic structure prevails for all compositions. The most crystallized sample was obtained at a G/N ratio of 0.6, which indirectly indicates that the combustion temperature reaches a maximum under these conditions. It is shown that the shift of the G/N ratio from the stoichiometric value (0.56) towards an excess of glycine or nitrates leads to a decrease in the temperature in the reaction zone and, as a result, to the formation of nanocrystals with smaller sizes and the formation of X-ray amorphous combustion products. Thus the possibility of  $\text{Sc}_{2-x}\text{Fe}_x\text{O}_3$  formation via solution combustion process was shown and the influence of glycine to nitrate ratio on its composition and average crystallite size was discussed in detail.

**Acknowledgments.** This work was supported by the Russian Science Foundation (project No 21-13-00260).

# HOW TO MAKE A COCKTAIL OF PALLADIUM CATALYSTS FROM COCA-COLA® AND (WATER-BASED ETHANOL SOLUTIONS) POTABLE ETHANOL? HETEROATOMS DOPING VS. SURFACE AREA OF CARBON SUPPORT

*Pentsak E.O.<sup>1</sup>, Galushko A.S.<sup>1</sup>, Cherepanova V.A.<sup>1</sup>, Ananikov V.P.<sup>1</sup>*

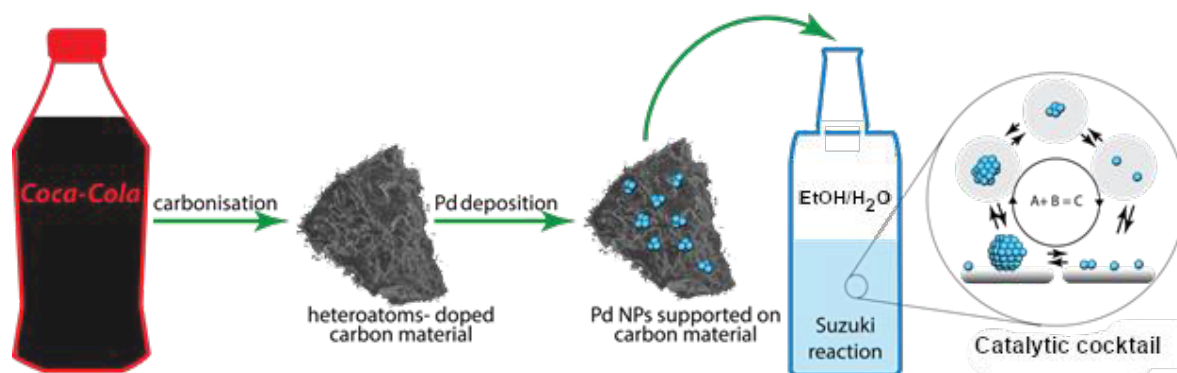
<sup>1</sup> Zelinsky Institute Of Organic Chemistry, Russian Academy Of Sciences, Moscow, Russia  
Student

[cherepanova.vera.a@gmail.com](mailto:cherepanova.vera.a@gmail.com)

Sparkling drinks such as Coca-Cola® can be considered as an affordable and inexpensive solution of carbohydrates, sulfur- and nitrogen-containing organic substances in phosphoric acid, which makes it an excellent precursor for production of heteroatom-doped carbon materials. In this study heteroatom-doped carbon materials were successfully prepared by simple and fast approach from the Coca-Cola Classic® and Coca-Cola Zero® by direct carbonization. Due to the low carbon fraction in Coca-Cola Zero®, it was possible to reach a higher level of phosphorus in the prepared carbon material, as well as to obtain additional doping with nitrogen and sulfur due to the presence of sweeteners and caffeine. The effect of carbon support doping with phosphorus, nitrogen and sulfur, as well as changes of specific surface area by ball milling on the catalytic activity of palladium catalysts was investigated for Suzuki-Miyaura and Mizoroki-Heck reactions. The contribution of heteroatom doping and specific surface area of carbon supports to the activity increase of supported catalysts was discussed. Also possibility of these reactions proceeding in 40% potable ethanol was studied. Moreover, we detected transformation of various palladium particles (complexes and nanoparticles) in reaction medium by mass-spectrometry and transmission electron microscopy, which indicates the formation of a cocktail of catalysts in a commercial 40% ethanol/water solution.

Coca-Cola® had recently been used to prepare unique N-doped micro-mesoporous caramel which was applied to boost electrochemical performance.<sup>1</sup> Coca Cola® had also recently been used to prepare porous carbon by hydrothermal carbonation to adsorb CO<sub>2</sub> and create supercapacitors<sup>2</sup>, as well as for synthesis of mesoporous graphitic carbon nitride nanosheets for photocatalytic hydrogen evolution<sup>3</sup>.

Coca-Cola® is widely available in all countries and is unexpensive ready-made solution of organic substances in phosphoric acid. Therefore, the use of Coca-Cola® in laboratory practice as a precursor of carbon materials can be economically viable. In this work, we decided to find out whether such popular drinks as Coca-Cola® can be directly used to prepare functional heteroatoms-doped carbon material; and also to investigate the catalytic cocktail formed in potable ethanol when using a supported palladium catalyst on carbon materials prepared from Coca-Cola®.



**Figure 1.** Supported Pd catalyst preparation from Coca-Cola®, prepared catalyst application in cross-coupling reaction and formation of a catalytic cocktail in ethanol solution.

## References

- [1] Shen, X. Z.; Huang, Y. D.; Liu, Z. J.; Ding, J.; Wang, X. C.; Zhang, Y.; Guo, Y.; Tang, X. C. *Journal of Alloys and Compounds* **2020**, 834.
- [2] Boyjoo, Y.; Cheng, Y.; Zhong, H.; Tian, H.; Pan, J.; Pareek, V. K.; Jiang, S. P.; Lamonier, J.-F.; Jaroniec, M.; Liu, J. *Carbon* **2017**, 116, 490.
- [3] Sun, S.; Gou, X.; Tao, S.; Cui, J.; Li, J.; Yang, Q.; Liang, S.; Yang, Z. *Materials Chemistry Frontiers* **2019**, 3, 597.

Acknowledgements. This work was supported by the Russian Science Foundation (project No 19-73-20124).

## CEO<sub>2</sub> – CALCEIN NANOCOMPOSITE AS AGENT FOR DIRECT MONITORING OF INTRACELLULAR ROS INACTIVATION

Chukavin N.N.<sup>1</sup>, Popov A.L.<sup>2</sup>, Shcherbakov A.B.<sup>3</sup>, Ivanov V.K.<sup>4</sup>

<sup>1</sup>Moscow State University, Moscow, Russia

<sup>2</sup>Institute of Theoretical and Experimental Biophysics of the Russian Academy of Sciences, Pushchino, Russia

<sup>3</sup>Kurnakov Institute of General and Inorganic Chemistry of the Russian Academy of Sciences

<sup>4</sup>Zabolotny Institute of Microbiology and Virology, National Academy of Sciences of Ukraine,

Kyiv, Ukraine

Student

[chukavinnik@gmail.com](mailto:chukavinnik@gmail.com)

Oxidative stress is one of the main causes of most diseases, including neurodegenerative, cardiovascular and cancer [1-2]. One of the strategies to prevent the development of intracellular oxidative stress is the development of new substances with pronounced antioxidant activity. Today nanotechnology makes it possible to obtain functional materials with desired properties for biomedical applications. One of the most promising materials with unique redox activity is nanodispersed cerium oxide (CeO<sub>2</sub>). Particularly, CeO<sub>2</sub> nanoparticles has enzyme-like activity such as catalase, superoxide dismutase and peroxidase which provide high antioxidant action in cells and tissues [3]. This activity is based on the presence of Ce<sup>4+</sup> and Ce<sup>3+</sup> ions in the crystal structure of cerium oxide and electron transfer between these ions and oxygen. Functionalization of CeO<sub>2</sub> nanoparticle surface by calcein causes the ability to detect the intracellular reactive oxygen species and their simultaneous inactivation. The formation of the CeO<sub>2</sub> – calcein complex leads to the fluorescence quenching. However, the interaction between cerium oxide and ligand with higher affinity, such as ROS, causes destruction of this complex. Thereby, the interaction between CeO<sub>2</sub> and ROS leads to the calcein release with the regeneration of their fluorescence.

We performed comprehensive analysis of CeO<sub>2</sub> – calcein nanocomposite properties which confirmed ultra-small (4-5 nm) size with negative ζ-potential (-30 mV) with high colloidal stability. Therefore, we performed an analysis of their biocompatibility using human mesenchymal stem cells (MSC). In addition, we have tested the antioxidant activity of CeO<sub>2</sub> – calcein nanocomposite in oxidative stress induced by H<sub>2</sub>O<sub>2</sub>. It was revealed that the nanocomposite does not exhibit cytotoxic activity to human MSC in concentrations below 1 mM, while maintaining their viability, metabolic activity and mitochondrial potential as in control group. The analysis of the nanocomposite bioactivity showed high antioxidant activity at 200 μM. The optimal concentration of the CeO<sub>2</sub> – calcein nanocomposite for intravital monitoring of intracellular ROS is also 200 μM.

In conclusion, our investigation of the biological activity of the CeO<sub>2</sub> – calcein nanocomposite in H<sub>2</sub>O<sub>2</sub>-induced oxidative stress showed a high potential of the nanocomposite application in photodynamic diagnostics and therapy.

### References

- [1] Alfadda A. A., Sallam R. M. *Journal of Biomedicine and Biotechnology* **2020**
- [2] Brieger K., Schiavone S., Miller F. J., Krause K. H. *Swiss medical weekly* **2012**, 142, w13659
- [3] Попов А. Л., Шчербаков А. В., Жолобак Н. М., Баранчиков А. Я., Иванов В. К. *Наносистемы: физика, химия, математика* **2017**, 8(6)

Acknowledgements. This work was supported by the Russian Science Foundation (project No 20-74-00086).

# PREPARATION OF SILVER NANOPARTICLES BY DECOMPOSITION SILVER HYDROXYMETHYLACETYLENIDE COORDINATION POLYMERS

*Chupina A.V.<sup>1,2</sup>, Abramov P.A.<sup>2</sup>*

<sup>1</sup>Novosibirsk State University, Novosibirsk, Russia

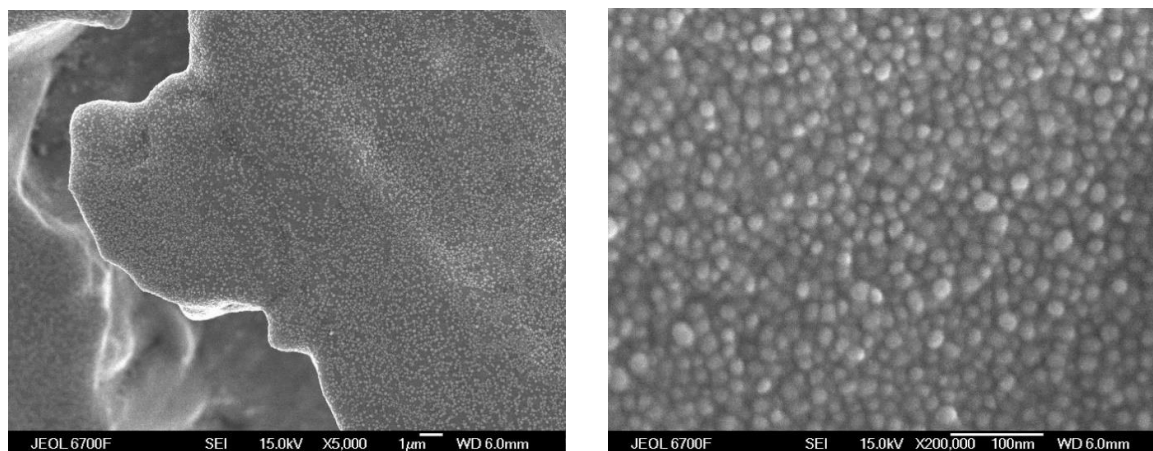
<sup>2</sup>Nikolaev Institute of Inorganic Chemistry SB RAS, Novosibirsk, Russia

Student

[a.chupina@g.nsu.ru](mailto:a.chupina@g.nsu.ru)

Among metal nanoparticles, silver nanoparticles (NPs) occupy a special place due to their unique physical and chemical properties. Examples include conductive inks, pastes and fillers, which utilize silver nanoparticles for their high electric conductivity, stability, and low sintering temperatures. Additional applications include molecular diagnostics and photonic devices, which take an advantage for the novel optical properties of these nanomaterials. An increasingly common application is the use of silver nanoparticles for antimicrobial coatings in textiles, keyboards, wound dressings, and biomedical devices. Hence the synthesis of stable colloids of silver NPs of a certain size is an important task of the modern chemistry.

In this work, we obtained coordination polymers based on silver propargylate (C-deprotonated propargyl alcohol, prop-2-yn-1-ol,  $C_3H_3OH$ ), which have a higher spontaneous detonation temperature than unsubstituted silver acetylenide. Addition of in situ generated hydroxymethylacetylenide to the aqueous solutions of  $AgNO_3$  in 1:1 molar ratio results in the formation of two new coordination polymers,  $\{AgNO_3 \cdot 2[Ag(C_3H_2OH)] \cdot 2/3H_2O\}_\infty$  (**1**) and  $\{AgNO_3 \cdot 3Ag(C_3H_2OH)\}_\infty$  (**2**). Storage of the crystalline samples of **1** or **2** under mother liquor at 5 °C for two weeks results in a new crystalline phase,  $\{AgNO_3 \cdot 2[Ag(C_3H_2OH)] \cdot H_2O\}_\infty$  (**3**). Another two weeks evolution yields  $\{AgNO_3 \cdot 2Ag(C_3H_2OH)\}_\infty$  (**4**). This product can be prepared in a large-scale amounts by changing of the reagent ratio between the hydroxymethylacetylenide and  $AgNO_3$  to 0.5:1. All products are colorless crystalline materials, and their structures were determined by single-crystal X-ray diffraction. They are highly light sensitive, in particular, in the presence of trace amounts of impurities.



**Figure 1.** SEM image of silver nanoparticles.

All substances were characterized by various physicochemical methods. The thermal explosion of the obtained compound **4** leads to the formation of silver nanoparticles, for which TEM and SEM images (Fig.1) were obtained, UV spectra were recorded, and the analysis of CV data in solution was carried out.

Acknowledgements. This work was supported by Russian President grant (MD-396.2021.1.3).

# CHARACTERIZATION OF $\text{Co}_3\text{O}_4$ NANOPARTICLE REDUCTION SINTERING AND APPLICATION TO FLEXIBLE DEVICE

*Darkhanbaatar N., Yoshidomi K., Mizoshiri M.*

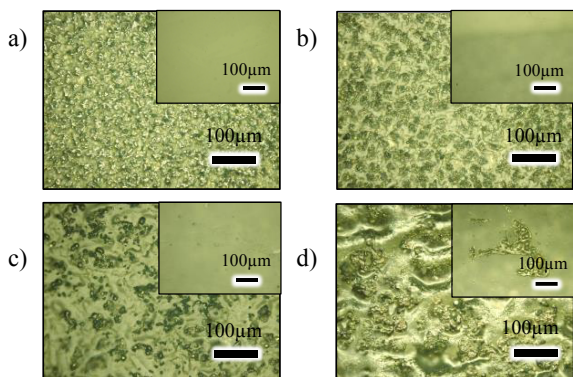
Nagaoka University of Technology and Science, Nagaoka, Japan  
Student

[s203050@stn.nagaokaut.ac.jp](mailto:s203050@stn.nagaokaut.ac.jp)

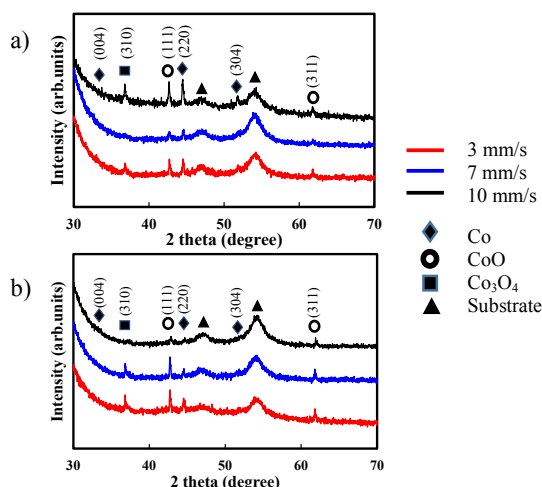
Metal direct writing using femtosecond laser reductive sintering has received attention in printed electronic. To date, Cu-based micro-temperature detectors were fabricated using femtosecond laser reduction of CuO nanoparticles by controlling the degree of reduction.  $\text{Cu}_2\text{O}$ -rich detector electrically connected Cu-rich electrodes were selectively formed[1]. However, direct writing of Co-based patterns in air has not been achieved. In this presentation, Co-based microstructures were fabricated on PET substrate using reductive sintering of cobalt oxide nanoparticles by femtosecond laser irradiation with a burst mode. We investigated the morphologies and the crystal structures of the patterns fabricated by various conditions.

A Co nanoparticle ink was prepared by mixing tricobalt tetroxide nanoparticles with the size of <100 nm (55wt%), a reductant agent of ethylene glycol (EG, 33 wt%), and a dispersant of polyvinylpyrrolidone ( $M_w \sim 10000$ , 12 wt%). The Co ink was spin-coated onto a flexible substrate, PET. The coated film was sintered in air using near-infrared femtosecond laser pulses operating with the wavelength of 780 nm and pulse duration of 120 fs. The laser pulses were focused using an objective lens with a numerical aperture of 0.45, and irradiated with a burst of 20 and 100 pulses. The intra-burst pulse repetition frequency was 80 MHz, corresponding to the time distance between sequential pulses of 12.5 ns. The burst repetition frequency was fixed as 0.8 MHz. The unsintered Co ink was removed from the substrate by rinsing in EG. The patterns were formed under the pulse energy of 0.74 nJ and writing speed of 3, 7, and 10 mm/s with a raster pitch of 5  $\mu\text{m}$ . The morphologies of the patterns were evaluated using optical microscope images. The crystal structures of the patterns were also examined using x-ray diffraction analysis.

Figure 1 shows the patterns fabricated on (a) glass, (b-d) on PET. The flexible substrate was damaged and re-oxidated under non burst mode, 80 MHz (100 pulses). On the otherhand, the patterns were successfully formed without significant damages for the substrates under the burst numbers were 20 and 50 with the writing speed of 10 mm/s. The crystal structures of the patterns on flexible substrates are shown in Fig.2. The more intense diffraction peaks corresponding to Co appeared at the burst number of 20 than that of 50. These results suggest that a increase of the pulse number caused the re-oxidation. This direct writing technique by controlling the number of burst pulses is useful for Co patterning with high purity.



**Fig 1.** State of both sides after laser sintering  
a) Glass 100 pulses 10 mm/s 0.74 nJ  
b) PET 20 pulses 10 mm/s 0.74 nJ  
c) PET 50 pulses 10 mm/s 0.74 nJ  
d) PET 100 pulses 10 mm/s 0.74 nJ



**Fig 2.** X-Ray Diffraction data graph  
a) 20 and b) 50 pulses

## References

[1] M. Mizoshiri, *et al.*, Appl. Phys. Express, 9 (2016) 036701

Acknowledgements. This work was supported by Funds for the Development of Human Resources in Science and Technology "2019 Initiative for Realizing Diversity in the Research Environment (Leading Type)"; The Ministry of Education, Culture, Sports, Science, and Technology (MEXT); and KAKENHI 20H02043.



REGULATION OF MORPHOLOGICAL PARAMETERS AND OPTICAL CHARACTERISTICS  
OF CHROMIUM-DOPED HYDROXYAPATITE NANOPARTICLES BY DIRECTIONALLY CHANGING  
THE PROCESSES OF THEIR FORMATION

*Demidova N.D., Sadetskaya A.V., Syukkalova E.A., Bobrysheva N.P., Osmolovsky M.G., Osmolovskaya O.M.*

Saint Petersburg State University, Saint Petersburg, Russia  
PhD student  
[dmdv.natalie@gmail.com](mailto:dmdv.natalie@gmail.com)

An actual problem in cosmetology is the development of multifunctional products that combine components with different functionality such as humidification, nutrition, masking. Such products composition may contain coloring biocompatible pigments. The introduction of such components allows to mask excessive pigmentation and skin imperfections.

Our approach is to use hydroxyapatite as the basis for biocompatible pigments. Hydroxyapatite (HAp) is a major component of bone tissue and stimulates the natural production of collagen. It is biocompatible, non-mutagenic and biodegradable material.

To mask red spots of the skin, it is optimal to use products with a green tint, which perfectly neutralize redness. In the case of white hydroxyapatite nanoparticles, changes in their color can be achieved by doping with ions of 3d elements. The introduction of 3d elements changes the energy spectrum of the nanoparticles and their optical properties. We suggest use Cr(III) as a dopant, which can stain hydroxyapatite green.

To regulate the hue and intensity of green pigments, it is possible to change the size and shape of nanoparticles, which in turn is carried out by changing the synthesis conditions. The use of a promising method of hydrothermal synthesis makes it possible to obtain doped hydroxyapatite nanoparticles of various morphologies by changing the temperature and duration of the process [1, 2]. In this work, to obtain chromium-doped hydroxyapatite nanoparticles, various mechanisms of nanoparticle formation were initiated by changing the synthesis procedure.

All the obtained samples were characterized by XRD, TEM, FTIR, SSA. The value of band gap was calculated based on absorption spectra.

According to the XRD data, it was revealed that the doping was successful, as evidenced by changes in the parameters of the crystal lattice and the absence of additional phases. Significant effect of the synthesis procedure on the size of the crystal cell of hydroxyapatite in the products was found.

According to TEM data, the samples are elongated rod-shaped single-crystal nanoparticles. The thickness of samples varies from 13 to 48 nm and also depends on the synthesis procedure. Doping leads to a change in the band gap from 4.7 eV (undoped HAp) to 3.7-3.8 eV. In addition, all the samples obtained are green in different shades.

Dependencies of nanoparticle morphological parameters and optical properties on synthesis procedure were established, allowing us to obtain nanoparticles with required specification.

#### References

- [1] Syukkalova E.A., Sadetskaya A.V., Demidova N.D., Osmolovsky M.G., Voznesenskiy M.A., Osmolovskaya O.M.// *Ceramics International*, **2020**, p. 1-13  
[2] Sadetskaya A.V., Bobrysheva N.P., Osmolovsky M.G., Osmolovskaya O.M., Voznesenskiy M.A.// *Materials Characterization*, Volume 173, **March 2021**, 110911

Acknowledgements. Scientific research was performed at the research park of St. Petersburg State University educational resource center of chemistry: Centre for X-ray Diffraction Studies, Chemical Analysis and Materials Research Centre, Centre for Optical and Laser Materials Research, Centre for Physical Methods of Surface Investigation and Interdisciplinary Resource Centre for Nanotechnology.

# IMPROVED PHOTODEGRADATION OF ANIONIC DYES USING A COMPLEX GRAPHITIC CARBONNITRIDE AND IRON-BASED METAL-ORGANIC FRAMEWORK MATERIAL

Doan H.V.,<sup>1,2</sup> Nguyen H.T.,<sup>2</sup> Ting V.P.,<sup>3</sup> Pham X.N.<sup>2</sup>

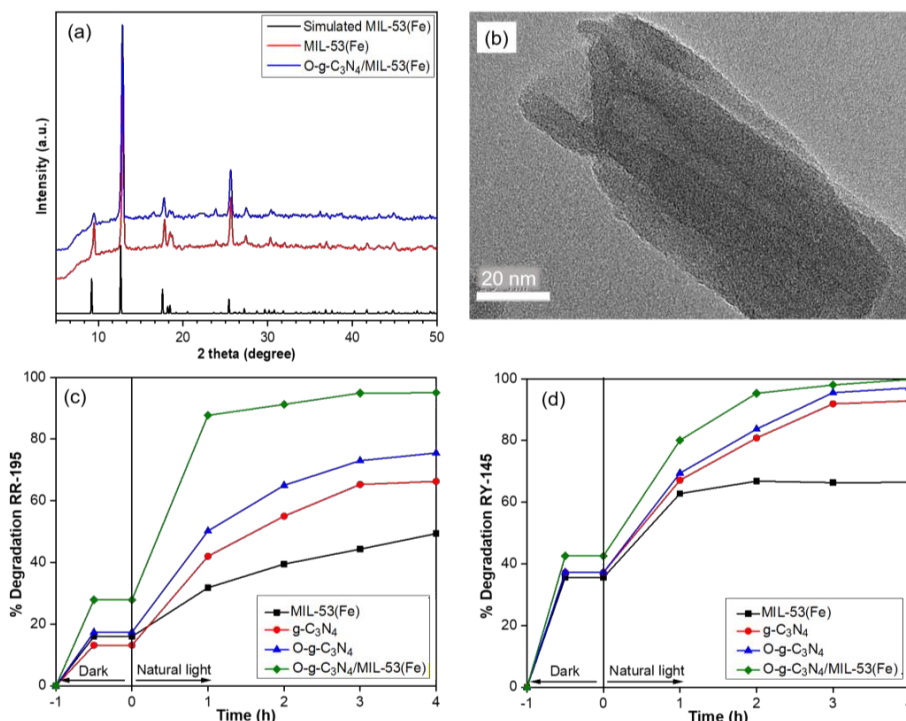
<sup>1</sup>School of Chemistry, University of Bristol, United Kingdom

<sup>2</sup>Department of Chemical Engineering, Hanoi University of Mining and Geology, Vietnam

<sup>3</sup>Department of Mechanical Engineering, University of Bristol, United Kingdom

[huan.doan@bristol.ac.uk](mailto:huan.doan@bristol.ac.uk)

Introducing heterostructure to graphitic carbon nitrides (g-C<sub>3</sub>N<sub>4</sub>) can improve the activity of visible-light-driven catalysts for efficient treatment of multiple toxic pollutants in water. Here we report for the first time that a complex material can be constructed from oxygen-doped g-C<sub>3</sub>N<sub>4</sub> and MIL-53(Fe) metal-organic framework using a facile hydrothermal synthesis and recycled polyethylene terephthalate from plastic waste. The novel multi-walled nanotube structure with unique interfacial charge transfer at the heterojunction in O-g-C<sub>3</sub>N<sub>4</sub>/MIL-53(Fe) composite showed an obvious enhancement in separation efficiency of the photochemical electron-hole pairs, resulting in narrow bandgap energy (2.30 eV compared to 2.55 eV in O-g-C<sub>3</sub>N<sub>4</sub>), high photocurrent intensity (0.17 mA cm<sup>-2</sup> compared to 0.12 mA cm<sup>-2</sup> and 0.09 mA cm<sup>-2</sup> in MIL-53(Fe) and O-g-C<sub>3</sub>N<sub>4</sub>, respectively), and excellent catalytic performance in the photodegradation of anionic azo dyes (95.1% RR-195 and 99.8% RY-145 degraded after 4 h, and only a minor change in the efficiency observed after four consecutive tests). These results demonstrate the development of new catalysts made from waste feedstocks, high stability and ease of fabrication, which can operate in natural light for environmental remediation.



**Figure 1.** (a) PXRD patterns of simulated MIL-53(Fe), as-synthesised MIL-53(Fe) and O-g-C<sub>3</sub>N<sub>4</sub>/MIL-53(Fe), showing MIL-53(Fe) crystals were successfully formed using the recycled polyethylene terephthalate and the MOF crystallinity was maintained during the facile synthesis of the novel O-g-C<sub>3</sub>N<sub>4</sub>/MIL-53(Fe) composite. (b) TEM image of O-g-C<sub>3</sub>N<sub>4</sub>/MIL-53(Fe) composite disclosing the appearance of multi-walled nanotubes with the onion-like walls. (c) and (d) Photocatalytic degradation of RR 195 and RY 145 using g-C<sub>3</sub>N<sub>4</sub>, O-g-C<sub>3</sub>N<sub>4</sub>, MIL-53(Fe) and O-g-C<sub>3</sub>N<sub>4</sub>/MIL-53(Fe), showing the higher degradation efficiency of the composite material compared to the pristine samples.

## References

- [1] Journal of Industrial and Engineering Chemistry **2020**, 90 (25), 358-370.
- [2] Journal of the Taiwan Institute of Chemical Engineers, **2020**, 114, 91-102.

**Acknowledgements.** This work was supported by the Ministry of Education and Training of Vietnam (B2021-MDA-03), the UK Engineering and Physical Sciences Research Council (EP/T517872/1) and the Royal Society of Chemistry (R20-8172)

# INVESTIGATE OF THE INFLUENCE OF A HIGHLY DISPERSED CATALYST ON THE THERMAL CRACKING PROCESS

*Dokuchaev I.S., Maksimov N.M., Tyshenko V.A.*

Samara State Technical University, Samara, Russia

Student  
e2.71@mail.ru

The declining reserves of traditional light oils are pushing the oil industry more and more to process heavier oils. [1]

The creation of technologies for the processing of vacuum gas oil and oil residues, alternative to expensive processes of catalytic cracking and hydrocracking, is urgent. [2]

One of the promising areas for processing vacuum gas oil and oil residues is thermocatalytic processes using highly dispersed systems.

We have proposed an alternative way of using the spent hydrotreating catalyst - in the process of thermal cracking with a suspended catalyst bed.

The aim of the research is to investigate the role of a spent industrial hydrotreating catalyst and hydrogen donors in the thermal cracking process.

In this work, a series of experiments was carried out with the subsequent analysis of products and processing of the results on the basis of the laboratory of the Department of «Chemical Technology for Oil and Gas Processing».

The following hydrocarbons were used as model compounds: n-dodecane (reagent grade), decalin (reagent grade), isopropylbenzene (reagent grade), toluene (reagent grade).

The tests were carried out on an plant with a micro-flow reactor under a pressure of 1.6 MPa in the temperature range of 400-440 °C, the LHSV in the range of 1-3 h<sup>-1</sup>, and the hydrogen circulation rate was 300 nm<sup>3</sup>/m<sup>3</sup>. The spent hydrotreating catalyst was loaded into the reactor after calcination at 470 °C in an amount of 4.0 cm<sup>3</sup>. The include in which is alumina oxide, the active phase is cobalt oxide (4.31%) and molybdenum oxide (20.52%).

The amount of desorbed ammonia according to the TPD results is 752 mmol NH<sub>3</sub> /g.

Thus, paraffinic hydrocarbons on a hydrotreating catalyst are most prefer to cracking, isomerization, and aromatic hydrocarbon formation.

It was also noted that the presence of aromatic hydrocarbons in the feed reduces the conversion of paraffinic hydrocarbons involved in the process.

Naphthenic hydrocarbons are most actively involved in dehydrogenation reactions and can act as a hydrogen donor and create a partial pressure of hydrogen in the reaction zone, which, on the one hand, can suppress cracking reactions, and on the other hand, in the presence of sulfur in the feedstock of the thermocatalytic process intigates a useful hydrodesulfurization reaction is possible.

The usability of the investigated catalyst in the process of cracking vacuum gas oil in the presence of a hydrogen donor was shown to promote. Hydrogen transfer reactions observing the optimal technological parameters leads to the hydrogenation of olefinic hydrocarbons and suppression of coke formation reactions with an increase in the selectivity of the process, thereby making the option of using this catalyst in the process of thermal cracking with a suspended catalyst bed technologically beneficial.

## References

- [1] Dehkissia S., Larachi F., Chornet E. Catalytic (Mo) upgrading of Athabasca bitumen vacuum bottoms via two-step hydrocracking and enhancement of Mo-heavy oil interaction. *Fuel*, **2004** – 83. – P. 1323-1331.  
[2] Ngoc Thuy Nguyena, Ki Hyuk Kanga, Pill Won Seoa, Narae Kanga, Duy Van Phama, Gyoo Tae Kima, and Sunyoung Parka, Hydrocracking of C<sub>5</sub> - Deasphalted Oil: Effects of H<sub>2</sub> and Dispersed Catalysts *Petroleum Chemistry*, **2021**, Vol. 61, No. 2, pp. 172–182.

SYNTHESIS OF ULTRASMALL GOLD NANOPARTICLES  
IN THE PRESENCE OF GUANOSINE MONOPHOSPHATE AND ADENOSINE TRIPHOSPHATE

Dominnik E.E., Ivanova N.K., Karpushkin E.A, Sergeev V.G.

Lomonosov Moscow State University, Moscow, Russia

Student

[dominnikjr@gmail.com](mailto:dominnikjr@gmail.com)

Gold nanoparticles (AuNPs) have recently attracted considerable attention due to their application in sensing, drug delivery, and anticancer therapy [1, 2]. In view of the biomedical applications, it is important to develop the so-called “green chemistry” approaches to obtain ultrasmall AuNPs. Herein we present a new method to prepare spherical colloidal AuNPs via the reduction of gold(III) complexes with adenosine triphosphate (ATP) and guanosine monophosphate (GMP).

Firstly, we investigated the formation of complexes via the interaction of  $\text{HAuCl}_4$  with the chosen nucleosides in neutral aqueous medium. In the case of both nucleosides, initially colorless samples turned dark orange or dark red upon the mixing, and the complex formation was manifested by the appearance of a band with maximum at about 350–450 nm in the electronic absorption spectra. The nature of the coordination interactions between  $\text{HAuCl}_4$  and the nucleosides was investigated by means of FTIR spectroscopy at different ratios of the components. According to the shift of the characteristic bands in the IR spectra, we suggested binding of Au(III) with ATP via the  $\text{C}^6\text{-NH}_2$  group, whereas GMP was coordinated via the  $\text{C}^6\text{=O}$  and  $\text{N}^7$  groups.

In the second part of the research, we attempted the reduction of Au(III)–nucleoside complexes with  $\text{NaBH}_4$  ( $\text{HAuCl}_4\text{:NaBH}_4$  ratio 1:2) and sodium citrate ( $\text{HAuCl}_4\text{:Na}_3\text{Citr}$  ratio 1:10). In the case of  $\text{NaBH}_4$ , we observed the appearance of plasmon band with maximum at 528 and 510 nm, respectively, in the spectra of the reduced Au(III)–GMP and Au(III)–ATP systems, reflecting the formation of ultrasmall (2–3 nm) spherical AuNPs directly confirmed by means of TEM. When  $\text{Na}_3\text{Citr}$  was used for the reduction agent, much larger particles with broader bimodal size distribution (major fractions of 4–7 and 28–32 nm) were formed. The obtained colloidal dispersions were stable against sedimentation during at least several weeks. Moreover, reduction of  $\text{HAuCl}_4$  in the absence of nucleosides, other conditions being the same, led to the formation of poorly stabilized AuNPs which were precipitated within several hours.

In summary, we demonstrated that monodisperse ultrasmall gold nanoparticles could be prepared via the reduction of Au(III) complexes with selected nucleosides under the action of sodium borohydride, whereas the reduction with sodium citrate afforded larger gold nanoparticles.

#### References

- [1] Sztandera K., Gorzkiewicz M., Klajnert-Maculewicz B. *Molecular pharmaceuticals*. 2018, 16(1), 1–23
- [2] Tseng W.B. et al. *Journal of Food & Drug Analysis*. 2020, 28(4), 521–538

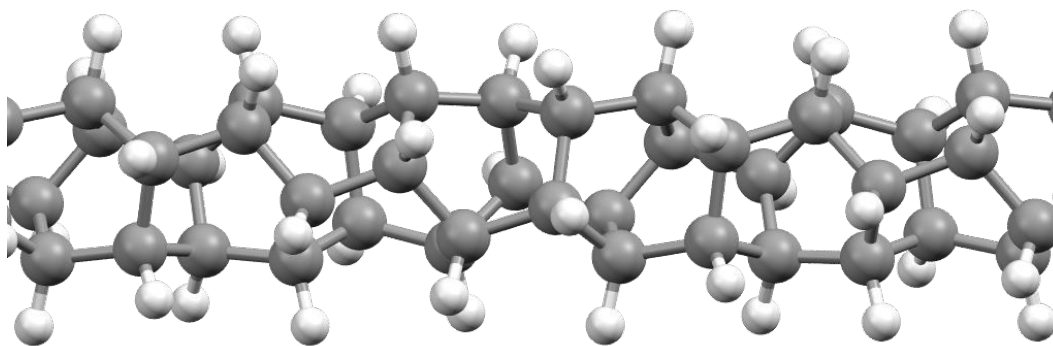
Acknowledgements. This study was financially supported by the Russian Foundation for Basic Research (project no 20-33-90296\20).

*Domnin A.V.<sup>1</sup>, Porsev V.V.<sup>1</sup>*

<sup>1</sup>Saint Petersburg State University, Saint Petersburg, Russia  
 Student  
[st040550@student.spbu.ru](mailto:st040550@student.spbu.ru)

Polytwistanes are a kind of carbon nano-threads - quasi-one-dimensional nanostructures containing  $sp^3$  hybridized carbon atoms and cyclic fragments in the main chain (usual derivatives of aromatic compounds). These structures have a special type of symmetry - line-group symmetry. This approach makes it possible to model objects with non-crystallographic orders of the axes, which greatly simplifies the modeling, making the calculations less resource-intensive. The second distinctive feature is that to calculate the same structure, so one can use different monomers (for example, CH, C<sub>2</sub>H<sub>2</sub>, C<sub>6</sub>H<sub>6</sub>). In contrast, the behavior of the resulting structures will be similar in the minimum energy range but very different in the areas of extreme twisting, i.e., e. when an irreversible deformation of the chemical structure of the initial compound occurs in the system. Another essential feature of nanowires is the possibility of incommensurate structures; such structures are characterized by the absence of translational symmetry, while they have line group symmetry.

The interest in modeling nanowires is due to several factors: these structures are still poorly studied by theoretical methods and experiments, calculations taking into account the symmetry of line groups are not used in existing works, which significantly limits researchers. Moreover, according to the results of molecular dynamics, these structures have interesting properties; for example, a study [1] indicates the possibility of self-assembly of polytwistane threads in nanobundles, which, in turn, are promising candidates for highly efficient storage of mechanical energy [2] and the creation of nanofiber [3, 4].



**Figure 1.** The structure of polytwistane is viewed along Oz axis (monomer - C<sub>6</sub>H<sub>6</sub>, symmetry group L12<sub>1</sub>, light gray balls - hydrogen atoms, dark gray - carbon atoms).

In this study, the modeling of the structure of polytwistane using various monomers is presented, an attempt to find the optimal structure parameters in the global energy minimum of this substance was made. A significant part of the research is devoted to studying the properties of polytwistane under torsion and axial deformations. Maps of the dependence of the band gap were constructed. Also, the dependence of Young's modulus on the twisting of the structure is obtained. Research was also carried out for an optimal computational scheme for modeling such structures in this study.

#### References

- [1] Saha, B. & Datta, A. *J. Phys. Chem. C* **2018**, 122, 19204–19211
- [2] Zhan, H., Zhang, G., Bell, J. M., Tan, V. B. C. C. & Gu, Y. *Nat. Commun.* **2020**, 11, 1905
- [3] Zhan, H., Zhang, G., Tan, V. B. C. & Gu, Y. *Nat. Commun.* **2017**, 8, 14863
- [4] Zhan, H., Gu, Y. & Wang, P. *ACS Appl. Nano Mater.* **2020**, 3, 10218–10225

# PHOTOSORPTION OF CHROME (VI) FROM AQUEOUS SOLUTIONS ON MODIFIED RUTILE TITANIUM DIOXIDE NANOPOWDERS

*Dorosheva I.B.<sup>1,2</sup>, Pechishcheva N.V.<sup>1</sup>, Korobitsyna A.D.<sup>1</sup>, Valeeva A.A.<sup>2,3</sup>, Sushnikova A.A.<sup>1</sup>, Petrova S.A.<sup>1</sup>, Shunyaev K.Yu.<sup>1</sup>, Rempel A.A.<sup>1,3</sup>*

<sup>1</sup>Institute of Metallurgy of the Ural Branch of the Russian Academy of Sciences, Yekaterinburg, Russia

<sup>2</sup>Institute of Solid State Chemistry, Ural Branch of the Russian Academy of Sciences, Yekaterinburg, Russia

<sup>3</sup>Ural Federal University, Yekaterinburg, Russia

[i.b.dorosheva@urfu.ru](mailto:i.b.dorosheva@urfu.ru)

Chromium is one of the most common pollutants in industrialized regions where metallurgical plants are located, as it is found in many steels and coatings. Its most stable and widespread compounds have oxidation states +3 and +6. It is known that Cr (III) has low toxicity, while Cr (VI) is carcinogenic to humans [1]. Currently, the development of a method that is simple to implement and does not require expensive reagents is a major challenge. A promising solution is the use of nanosized titanium dioxide as a photosorbent, since this compound is chemically stable, non-toxic, readily available, and inexpensive. In this regard, the aim of this work is to modify commercial titanium dioxide to increase its photosorption characteristics with respect to Cr (VI) ions.

The initial titanium dioxide powder (LLC Komponent-reaktiv, chemically pure) with a coherent scattering region (CSR) size is about 100 nm was subjected to high-energy milling in a PM 200 (Retsch, Germany) planetary ball mill. The grinding balls and the inner wall of the grinding vials were of Y<sub>2</sub>O<sub>3</sub> stabilized ZrO<sub>2</sub> to minimize powder contamination during grinding. Nanopowders were produced under the following milling conditions: the ball-to-powder weight ratio was 10 : 1; the milling liquid used was isopropanol, CH<sub>3</sub>CH(OH)CH<sub>3</sub>; milling time of 240 and 480 min; rotation direction reversed every 15 min; interval between direction reversals, 5 s; rotation speed of the disk supporting the grinding vials, 500 rpm.

X-ray phase analysis of the initial and milled TiO<sub>2</sub> nanopowders was performed on a D8 ADVANCE (Bruker, Germany) diffractometer (Cu-K<sub>α</sub> radiation). The data were recorded in the step-by-step scanning mode with  $\Delta(2\theta) = 0.021^\circ$  in the  $2\theta$  angle range from 5° to 102° with high statistics. The specific surface area of all powders was measured by the BET method using a Nova 1200e analyzer (Quantachrome Instruments, USA) with preliminary degassing at 150 °C for 60 min. The ability of nanopowders to adsorb chromium (VI) from its aqueous solutions with a concentration of 50 mg/L in the pH range from 4 to 6.3 (pH was maintained with an acetate buffer solution) under the action of ultraviolet radiation (source - low-pressure mercury lamp, range of maximum radiation intensity 200-300 nm, power 11 W). In this case, the sorption technique described in [2] was used.

According to XRD analysis the initial TiO<sub>2</sub> consists of 95% rutile and 5% anatase phases with CSR sizes are about 120 and 70 nm, respectively. Subsequent milling for 240 min leads to a decrease in the CSR size of anatase particles to 40 nm and rutile to obtain particles of two average CSR sizes: 53 and 8 nm. An increase in the milling time to 480 min did not affect the CSR size; however, it made it possible to increase the specific surface area, which is an important parameter for the sorption efficiency. Thus, the initial value of 8 m<sup>2</sup>/g was increased to 21, and then to 30 m<sup>2</sup>/g.

The maximum adsorption efficiency of Cr (VI) on the initial powder under illumination was 18%; the modification of rutile led to an increase in its value to 67% at milling for 240 min and up to 95% at milling for 480 min. The maximum sorption in all cases is observed at pH = 5. The obtained data correlate well with the values of the specific surface area: with its increase, the maximum adsorption efficiency under illumination increases. Without illumination, for the initial powders and powders after milling for 240 and 480 min, the adsorption efficiency of Cr (VI) is low and amounts to 0.8, 9, and 18%, respectively.

Thus, in this work, commercial titanium dioxide was modified by high-energy milling, which made it possible to significantly reduce the CSR size (down to 8 nm) and increase their specific surface area (up to 30 m<sup>2</sup>/g). Because of the modification of titanium dioxide (95% rutile), the adsorption efficiency of Cr (VI) was increased (up to 95%). The efficiency of using UV irradiation during sorption has been shown.

## References:

- [1] *Water, Air, and Soil Pollution*. **2015**, 226(1), 2252
- [2] *AIP Conference Proceedings*. **2020**, 2313, 050024

Acknowledgements. This work was supported by the Russian Science Foundation (project No 21-73-20039). The authors are grateful to Alexander V. Varaksin for BET measurements

# SINGLE EXCITED DUAL BAND LUMINESCENT HYBRID CARBON DOTS–TERBIUM CHELATE NANOTHERMOMETER

*Dovzhenko A.P.<sup>1</sup>, Zairov R.R.<sup>1</sup>, Mustafina A.R.<sup>2</sup>.*

<sup>1</sup>Kazan (Volga region) Federal University, Kazan, Russia

<sup>2</sup>Arbuzov Institute of Organic and Physical Chemistry, FRC Kazan Scientific Center, Russian Academy of Sciences, Kazan, Russia

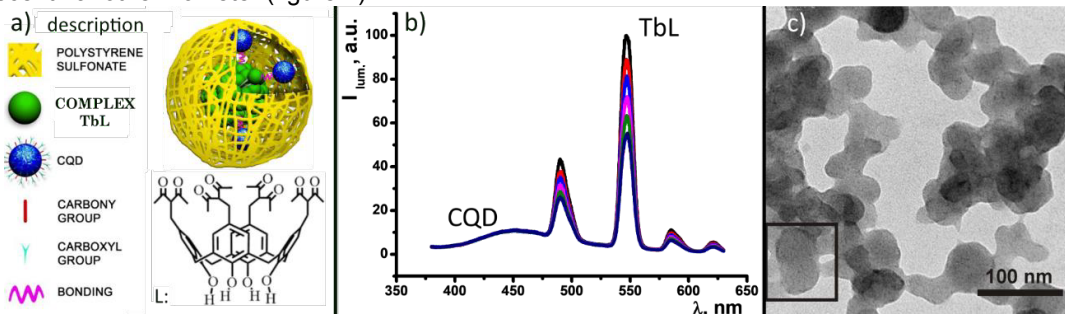
Postgraduate student

[aleksej\\_dovzhenko@mail.ru](mailto:aleksej_dovzhenko@mail.ru)

Intracellular temperature attracts special attention in last decades. This essential physiological property is accountable for the rates of biological reactions and the biomolecule diffusion course, such as exocytosis, oxidation phosphorylation, and the transmembrane transport of ions. That makes cell temperature measurements crucial in a big number of practical applications. Luminescence-based temperature sensing is outstanding in this sphere due to its merits of being noninvasive and precise [1].

$\text{Ln}^{3+}$ -based species possessing narrow emission bands, large Stokes shift, and high emission quantum yields inspired many reports on  $\text{Ln}^{3+}$ -based thermometers with outstanding sensitivity, temperature resolution, and robustness in the last decade. In this regard, implementation of  $\text{Ln}^{3+}$ -based materials to hybrid nanostructures is a budding strategy for design of novel ratiometric nanothermometers [2]. Among luminescent nanomaterials, photoluminescent carbon dots have emerged as important materials in sensing and cell imaging. However, most CD-based temperature sensors rely on fluorescence quenching processes, which cannot lead to accurate intracellular thermal sensing due to the same influence of many factors such as the presence of metal ions, pH changes and nonuniform distribution of probes. All of the drawbacks mentioned above can be eliminated via introducing second not overlapping luminescent component through the built-in calibrations of two emission bands. Thus, for biological samples, which are nonisotropic, it is highly desirable to design novel bicomponent temperature sensors characterized with two well-resolved and intensity comparable luminescence peaks that possess both strong emission and submicron scale [3].

In this work, was developed a facile strategy for synthesis of novel hybrid polystyrenesulfonate(PSS)-coated nanoparticles consisted of carbon dots (CD) and  $\text{Tb}^{3+}$  complex as a single excited dual band luminescent nanothermometer (figure 1).



**Figure 1.** Schematic description of hybrid nanoparticle and structure of ligand of complex [TbL] (a), emission spectra of this nanoparticles ( $I_{\text{ex}} = 360 \text{ nm}$ ) as a function of temperature (b), TEM image of dried colloids (c)

Ligand environment of the  $\text{Tb}^{3+}$  complex had to satisfy the specific requirements, such as: (1) high complex stability, (2) incomplete coordination sphere of  $\text{Tb}^{3+}$  ions, (3) efficient and temperature responsive  $\text{Tb}^{3+}$ -centered luminescence. The  $[\text{TbL}]^+$  complex with 1,3-diketone derivatives of calix[4]arene (L) fits well to the aforesaid requirements. The capacity of the hybrid nanoparticles to simultaneously emit in the blue and green regions of spectrum originates from two different emissive components CDs and  $[\text{TbL}]^+$  complex, correspondingly. The joint incorporation of green and blue emitting blocks into the polysodium polystyrenesulfonate (PSS) aggregates is carried out through the solvent-exchange synthetic technique. The coordinative binding between  $\text{Tb}^{3+}$  centers and CD surface groups both facilitates the joint incorporation of  $[\text{TbL}]^+$  complexes and the CDs into the PSS-based nanobeads and affects their fluorescence intensity. The binding of the blue and green emitting components is highlighted as a tool for tuning the sensing properties of the nanoparticles. The tuning of sensing properties, in turn, both enables to develop the colloids for monitoring of temperature changing within 25–50 °C through the differently emitting registration channels and to transform the colloids into ratiometric temperature sensors through the easy variation of the synthetic conditions. Due to their unique optical properties, temperature sensing over the range of 35–45 °C can be accomplished via changes in fluorescence intensity with high sensitivity values ( $S_f = 3.55 \% \text{ } ^\circ\text{C}^{-1}$ ).

## References

- [1] Gong D. et al. *Sens. Actuators B Chem.* 2017, 252, 577–583.
- [2] Zairov R.R., Dovzhenko A.P. et al. *scientific reports* 2020, 10, № 1, 20541.
- [3] Shi X. Li Z. et al. *Small* 2019, Vol, 15, № 48, 1901507.

# STRUCTURE AND SEPARATION PERFORMANCE OF NOVEL MIXED MATRIX MEMBRANES CONTAINING IONIC LIQUID AND STAR MACROMOLECULES

*Dubovenko R.R.<sup>1</sup>, Rostovtseva V.A.<sup>1</sup>, Vinogradova L.V.<sup>2</sup>, Polotskaya G.A.<sup>1,2</sup>, Pulalina A.Yu.<sup>1</sup>*

<sup>1</sup>Saint Petersburg State University, Saint Petersburg, Russia

<sup>2</sup> Institute of Macromolecular Compounds RAS, Saint Petersburg, Russia

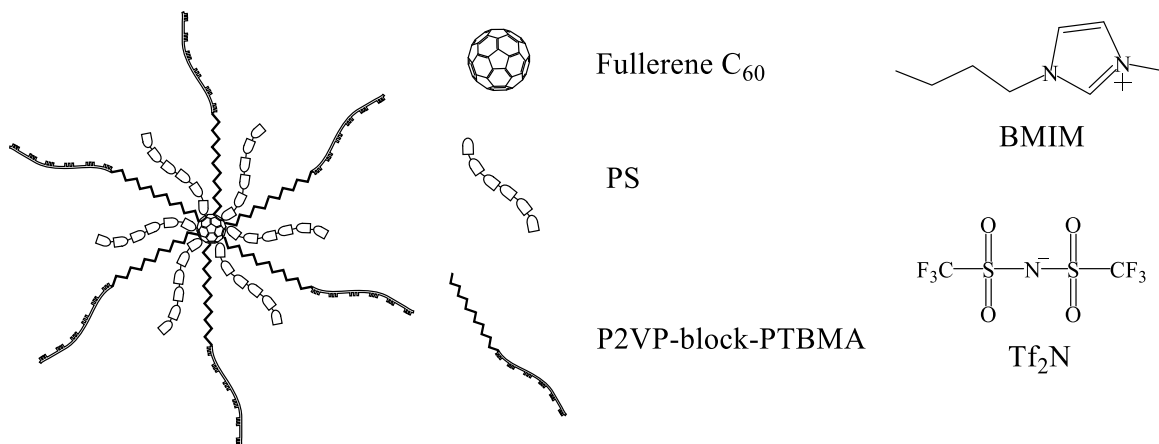
Student

[st062444@student.spbu.ru](mailto:st062444@student.spbu.ru)

Nowadays development of novel environmentally friendly and cost-effective technologies is the main direction of modern industry. Membrane processes are one of the most perspective technologies due to their low energy consumption, high performance, compact equipment, and the possibility of a continuous and automatic process. Particular attention is paid to pervaporation (or evaporation through the membrane) which is widely used for the purification, concentration and fractionation of liquids including azeotropic, close boiling-point and thermally unstable mixtures, since it does not require high temperatures or additional reagents.

Polymers are promising membrane materials due to their low cost, mechanical and thermal stability. Various methods are used for increasing and improving transport properties of polymer membranes. One of most perspective methods is production of mixed matrix membrane combining advantages of materials with different nature. Application of ionic liquids (IL) as polymer modifiers have shown their positive effect on the permeability and selectivity of the membrane process. However, a significant problem is the leaching of ILs from the polymer matrix, which makes it necessary to improve methods of IL immobilization.

Thus, a new complex membrane modifier based on hybrid star-shaped macromolecule (HSM) and [BMIM] [Tf<sub>2</sub>N] (1:1) ionic liquid has been proposed (**Figure 1**). Glassy poly(2,6-dimethyl-1,4-phenylene oxide) (PPO) was selected as the polymer matrix due to its low cost and high mechanical strength. A hybrid star-shaped macromolecule consists of a small core C<sub>60</sub>, 6 arms of nonpolar polystyrene (PS), and 6 polar copolymer of poly(2-vinylpyridine-block-poly-tret-butylmetacrylate) (P2VP-block-PTBMA).



**Figure 1.** Modifiers: HSM and IL.

The effect of modifiers on the structure and physicochemical properties of membranes was studied using scanning electron microscopy, X-ray diffraction, differential scanning calorimetry and thermogravimetric analysis. The transport properties of the membranes were estimated based on the data of sorption experiments. The overall separation performances for water – lactic acid mixtures are investigated systematically. The task of lactic acid dehydration is related to industrial challenges such as wide application of acid in the food industry, production of biodegradable polymers, as well as biocompatible polymers for medical purposes. It was found that hybrid membrane was essentially permeable and selective to water (water content in permeate is up to 99.8%). It was established that ionic liquids in combination with star macromolecules could be a promising approach as membrane modifiers to achieve higher transport properties.

**Acknowledgements.** This work was supported by the Russian Science Foundation (project No 18-79-10116). The authors are grateful to the resource centers of St. Petersburg State University: "Thermogravimetric and Calorimetric Research Methods", "Nanotechnology", "Centre for X-ray Diffraction Studies", "Cryogenic Department" and "Computing Center"



## ON THE THERMAL STABILITY OF CUBIC ZrO<sub>2</sub> AND ITS TRANSFORMATION

*Dzhevaga E.V.<sup>1</sup>, Popkov V.I.<sup>2</sup>*

<sup>1</sup>Saint Petersburg State Institute of Technology, Saint Petersburg, Russia

<sup>2</sup>Ioffe Institute, Saint Petersburg, Russia

Student

[dzhevaga.katya@mail.ru](mailto:dzhevaga.katya@mail.ru)

Materials based on nanosized cubic zirconium dioxide (*c*-ZrO<sub>2</sub>) are actively used for catalysis, luminescence, sorption of heavy metals, etc. [1]. It is difficult to synthesize *c*-ZrO<sub>2</sub> nanoparticles since the reactions for their preparation often lead to the formation of mixed phases. The addition of dopants in the form of various metal cations, as is known, promotes the stabilization of high-temperature phases; however, the properties and stability of such doped oxides noticeably deteriorate due to the presence of large amounts of chemical stabilizers, which adversely affect their practical applicability [2].

In this work, a nanopowder of undoped cubic zirconia was obtained by the method of glycine-nitrate combustion from zirconyl nitrate ZrO(NO<sub>3</sub>)<sub>2</sub>·2H<sub>2</sub>O and glycine C<sub>2</sub>H<sub>5</sub>NO<sub>2</sub> with a molar ratio of glycine and nitrate ions G/N = 0.3, and its thermal stability was also studied and structural transformations.

According to the results of complex thermal analysis in dynamic air flows in the temperature range from 40 to 1300 °C, the sample demonstrates two main areas of weight loss. The first, which is about 5% in the range of 70-500 °C, refers to the decomposition of unreacted glycine. The second region - 4.6% by mass, is located between 500-762 °C with a maximum of 668 °C, which, judging by the change in the ion current values, is associated with the oxidation of carbon residues to CO<sub>2</sub>. Subsequently, the *c*-ZrO<sub>2</sub> nanopowder was calcined in an air atmosphere in the temperature range 100-1000 °C with a step of 100 °C for 2 hours under atmospheric conditions (heating rate 10 °C/min) in order to study the effect of the annealing temperature on its physicochemical properties.

According to the results of X-ray phase analysis, the stability of the cubic modification remains up to a temperature of 500 °C, after which the samples undergo a tetragonal-monoclinic transformation, the proportion of the latter phase with an increase in the annealing temperature increases from 3.5 to 95.3%. Also, with an increase in the calcination temperature, the agglomeration of particles noticeably increases, which affects the homogeneity of the powder and, according to the data of low-temperature adsorption of nitrogen, contributes to a decrease in the specific surface area from 25.4 to 6.7 m<sup>2</sup>/g. According to the data of infrared spectroscopy, the presence of carbonate and nitrate groups is noted in the samples annealed to 700 °C, which is in good agreement with the data of thermal analysis.

### References

- [1] Ismail R., Arfaoui J., Ksibi Z. *Transit. Met. Chem.* **2020**, 45, 501–509  
[2] Lange F. F. *J. Mater. Sci.* **1982**, 17, 240

Acknowledgments. This work was supported by the Russian Science Foundation (project № 21-13-00260).

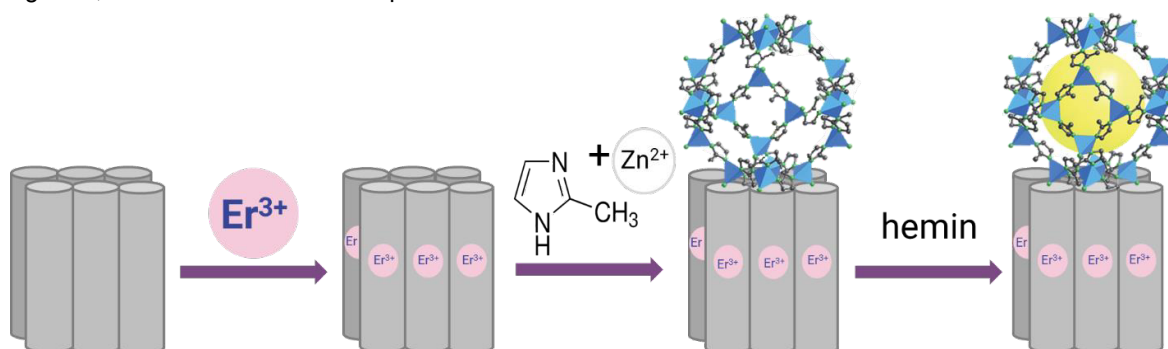
# CREATING A NANOCOMPOSITE BASED ON ENCAPSULATED HEMIN IN ZIF-8 AND TITANIUM DIOXIDE NANOTUBES

*Efimova S.A.<sup>1</sup>, Ikonnikova E.V.<sup>1</sup>, Vinogradov A.V.<sup>1</sup>*

<sup>1</sup>SCAMT institute, ITMO University, Saint Petersburg, Russia  
Efimova Sofya Andreevna  
[efimova@scamt-itmo.ru](mailto:efimova@scamt-itmo.ru)

Tissue regeneration *in situ* is one of the main tasks of functional materials science, aimed at restoring functional and anatomical properties after traumatic, infectious, or degenerative diseases. New therapeutic approaches include the use of advanced medical devices for the controlled delivery of bioactive molecules or growth factors to the affected area. [Ошибка! Источник ссылки не найден.] In this study, an alternative method of biocomponents localization is proposed to recover the structural integrity of the integuments.

This approach involves the production of nanotubes consisting of titanium dioxide and capable of self-ordering on titanium substrates by electrochemical anodizing. They can be easily integrated into current titanium implant technology having improved bioactivity, mechanics, and surface modification compared to conventional analogs. [0] Doping the nanotubes with  $\text{Er}^{3+}$  ions makes it possible to obtain up-conversion properties ( ${}^2\text{H}_{11/2} \rightarrow {}^4\text{I}_{15/2}$  with a maximum of 520 nm,  ${}^4\text{S}_{3/2} \rightarrow {}^4\text{I}_{15/2}$  with a maximum of 550 nm, and  ${}^4\text{F}_{9/2} \rightarrow {}^4\text{I}_{15/2}$  with a maximum of 670 nm) when they are illuminated by IR-light. The penetrating power of IR-rays is higher than that of UV-rays [0], which makes it possible to use the nanocomposite in different focal points of the organism. The application of the process of converting electromagnetic radiation with an increase in the energy level of the system optimizes the photocatalytic characteristics of traditional UV-active photocatalysts. [Ошибка! Источник ссылки не найден.] UV-radiation promotes proton generation due to the fact that the photoinduced "holes" firstly reach the water molecules and interact with them. The zeolite imidazolate framework (ZIF-8) used for growth factor encapsulation is capable of decomposing in an acidic environment, which makes it attractive for targeted delivery of bioactive components, for encapsulation, transport, and selective pH-mediated release. [Ошибка! Источник ссылки не найден.] The exarticulation of gemin into the biological environment during the metal-organic framework destruction leads to the division and reproduction of living cells, as well as to their further proliferation.



**Figure 1.** The scheme of the project

The study shows the synthesis of a nanocomposite and analyzes the experimental results to establish the parameter – structure – property relationship. In the future, it is planned to evaluate the reproducibility of the obtained data and the biocompatibility of the materials. This fundamental research project is of great importance for the applications of titanium bone implants in medicine.

## References

- [1] Sharsheeva, A., Iglin, V. A., Nesterov, P. V., Kuchur, O. A., Garifullina, E., Hey-Hawkins, E., Ulasevich, S. A., Skorb, E. V., Vinogradov, A. V., Morozov, M. I. *Journal of Materials Chemistry* **2019** B, 7(43), 6810–6821.
- [2] Nah, Y. C., Paramasivam, I., Schmuki, P. *ChemPhysChem* **2010**, 11(13), 2698–2713.
- [3] Wu, S., Butt, H.-J. *Physical Chemistry Chemical Physics* **2017**, 19, 23585–23596.
- [4] Roslyakov, I. V., Napolskii, K. S., Stolyarov, V. S., Karpov, E. E., Ivashev, A. V., Surtaev, V. N. *Russian Microelectronics* **2018**, 47(4), 226–233.
- [5] Hu, X., Li, G., Yu, J. C. *Langmuir* **2010**, 26(5), 3031–3039.

## RELATIONSHIP OF MORPHOLOGICAL PARAMETERS, OPTICAL AND PHOTOCATALYTIC PROPERTIES OF TB-SNO<sub>2</sub> NANOPARTICLES

*Fomkina A.S., Kolokolov D.S., Bobrysheva N.P., Osmolowsky M.G., Voznesenskiy M.A., Osmolovskaya O.M.*

Saint Petersburg State University, Saint Petersburg, Russia  
[annafomkina212@gmail.com](mailto:annafomkina212@gmail.com)

Today there is an acute problem of wastewater pollution with cyclic organic matter, which poses a threat to human health and life and harm the environment. For the implementation of the cleaning process, it is important that it is environmentally friendly, cheap and does not require the use of complex equipment. In this regard, the urgency of study the process of photocatalysis on semiconductors has increased.

Among a large number of semiconductor materials, tin dioxide stands out with a rutile-type structure, which is tolerant to substitution. We propose to dop the SnO<sub>2</sub> matrix with Tb<sup>3+</sup> ions due to the presence of luminescence upon excitation in the visible region.

Depending on the synthesis conditions, it is possible to optimize the morphological parameters (size, shape), which affects the photocatalysis process and increases its efficiency. It is known from the work of our laboratory [1] that spherical particles are obtained by a simple coprecipitation method, and hydrothermal treatment leads to the formation of nanorods.

Spherical particles were obtained by coprecipitation, and additional hydrothermal treatment led to the formation of cubic nanoparticles. All the samples obtained were characterized by X-ray diffraction, TEM, FTIR, Raman spectroscopy, the specific surface area was calculated using the BET method, absorption spectra were taken, from which the band gap was calculated. The organic dye Methylene Blue (MB), which has an absorption maximum at 664 nm, was taken as a model system for studying photodegradation. We obtained the kinetic dependences of the photocatalysis of MB and studied the products of its decomposition by mass spectroscopy to establish a possible reaction mechanism.

To create environmental conditions close to real, we carried out the photocatalytic decomposition of an uncolored solution of oxytetracycline (an antibiotic with a condensed four-cyclic system in structure). The degradation coefficients were estimated by spectrophotometry (at the absorption maxima of 274 nm and 354 nm) and chromatography, and the results obtained by these methods were compared.

Thus, depending on the particle shape and concentration of the doping ion, organic pollutants can be effectively decomposed with using available technical means.

### References

[1] I.E.Kolesnikov, D.S.Kolokolov, M.A.Kurochkin, M.A.Voznesenskiy, M.G.Osmolowsky, E.Lähderant, O.M.Osmolovskaya // Journal of Alloys and Compounds, Volume 822, 153640

Acknowledgements. This work was supported by the Russian Foundation for Basic Research (project No 20-03-00762 A). Scientific research was performed using the equipment of the Research Park of St. Petersburg State University (Centre for X-ray Diffraction Studies, Chemical Analysis and Materials Research Centre, Centre for Innovative Technologies of Composite Nanomaterials, Centre for Optical and Laser Materials Research, Centre for Magnetic Resonance).

CHARGE-ASSISTED HYDROGEN BONDED ORGANIC FRAMEWORKS (CAHOF) AS A NEW CLASS OF SUPRAMOLECULAR ORGANIC RECOVERABLE AND SELF-HEALING HETEROGENEOUS BRØNSED ACIDS CATALYST. CATALYTIC PERFORMANCE AND ENCAPSULATION OF METAL NANOPARTICLES.

*Gak A.S.*<sup>1,2</sup>, *Kuznetsova S.A.*<sup>2</sup>, *Riazanov V.I.*<sup>3</sup> *Yunusov S.M.*<sup>2</sup>, *Nelyubina Y.V.*<sup>2</sup>, *Belokon Y.N.*<sup>2</sup>

<sup>1</sup>Moscow State University, Faculty of Materials Science, Moscow, Russia

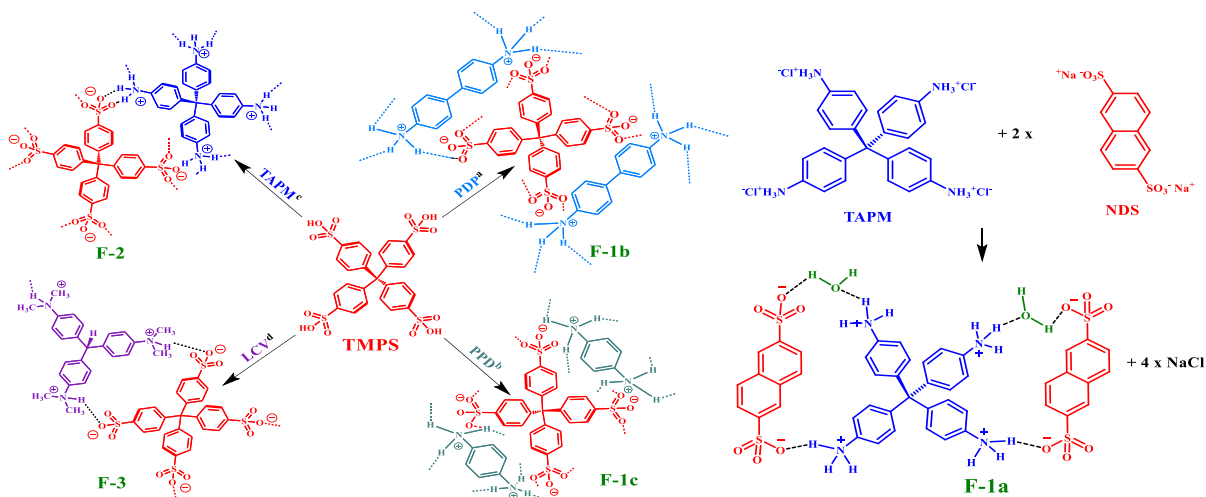
<sup>2</sup>A.N.Nesmeyanov Institute of Organoelement Compounds of Russian Academy of Sciences

<sup>3</sup>Mendeleev University of Chemical Technology of Russia, Moscow, Russia

Student

alexandrg03@gmail.com

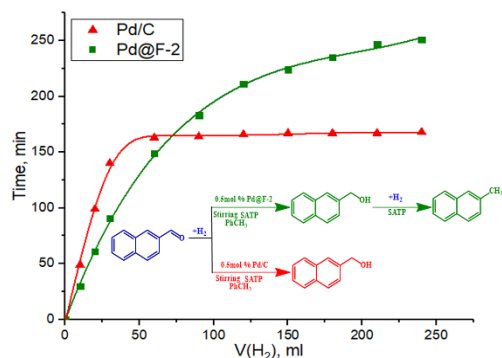
We propose the preparation of a new type of heterogeneous supramolecular recoverable acidic catalysts based on ionic interactions of multicharged organic cations and anions by simple acid-base neutralization of commercially available reagents (Scheme 1). The materials were stabilized by ionic and hydrogen bonds (Charge-assisted hydrogen bonded organic frameworks, CAHOFs). The CAHOFs were characterized by SEM, NMR, EDX, elemental and X-ray structural analyses.



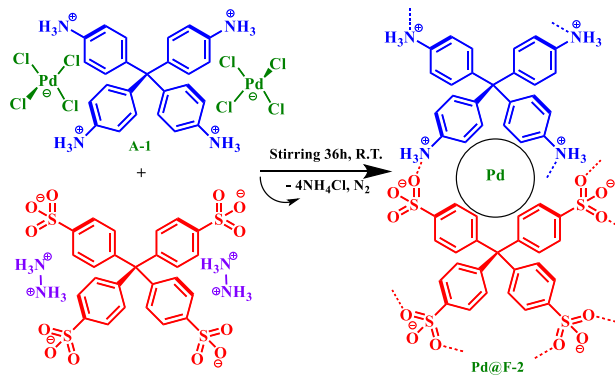
**Scheme 1** – Synthesis of CAHOFs

The catalytic performance of CAHOFs have been investigated in a number of industrially important reactions, usually catalyzed by Brønsted acids, such as epoxy ring opening with alcohols and water, the preparation of acetals, and a Diels-Alder reaction. A novel synthetic protocol was elaborated and implemented to produce 20 different acetals with yields up to 99%.

CAHOFs were crystalline, heterogeneous porous materials that are potentially capable of receiving „guests“. It seemed possible to use such porous framework structures to encapsulate metal nanoparticles inside the frameworks voids, stabilizing them from further self-coagulation. The idea was realized and Pd@F-2 prepared as shown on Scheme 2. Pd@F-2 functioned as a synergistic catalyst by the combination of acidic ammonium group and metal nanoparticle catalytic performances. This synergistic effect is illustrated in Figure 1 by the hydrogenation of 2-formylnaphthalene with Pd@F-2 as compared to Pd/C catalysis. Whereas Pd/C hydrogenated naphthalene aldehyde to 2-hydroxynaphthalene, Pd@F-2 brought about the complete hydrogenation to methylnaphthalene (Figure 1).



**Figure 1** - Catalytic performance of Pd@F-2



**Scheme 2** - Synthesis of a Pd@F-2

<sup>1</sup>Saint Petersburg State Institute of Technology (Technical University), Saint Petersburg, Russia  
Student

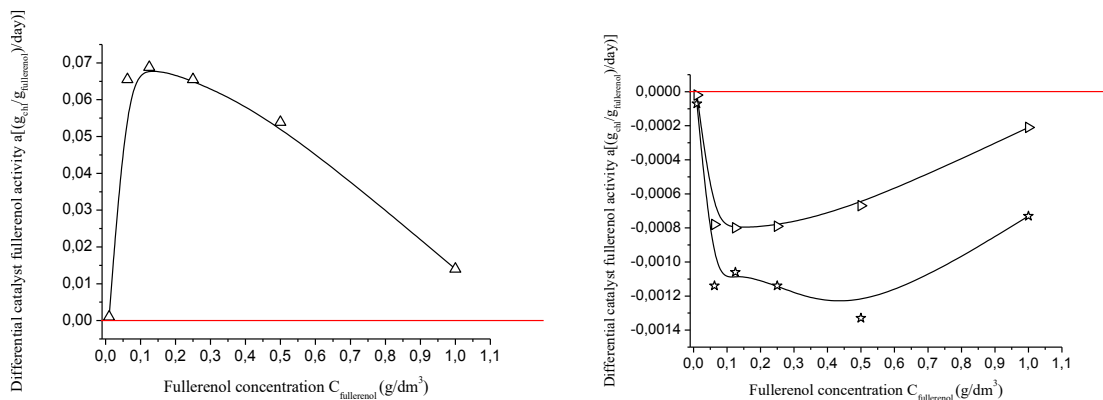
liubov.g.v@gmail.com

This article continues the cycle of articles, concerning the synthesis, identification and properties investigation of fullerenols [1-2].

We report about the investigation of fullereneol -  $C_{60}(OH)_{24}$  in bio-testing, using as test micro-organism "Chlorella vulgaris beijer" – very popular alga for bio-testing. We shall report about the kinetics in the system: chlorella vulgaris beijer (bio-component)-fullereneol (catalyst/inhibitor)-water (solvent) in the oxidation stress. It was organized by use as a breeding medium for chlorella  $H_2O_2$  solution with the concentration  $C_{H_2O_2} = 1 \text{ g/dm}^3$ .

Chlorella growth or oppression were investigated in open transparent in the visible area cylindrical polystyrene test tubes at room temperature under illumination by standard incandescent lamp (Phillips E27 – 40 Wt) for the period of 9 days. Catalyst concentrations were varied in the range  $0.01 - 1.0 \text{ g/dm}^3$ . Chlorella Vulgaris concentrations were determined by the method of turbidimetry – by the determination of optical density of scattered light in the direction of propagation of the incident beam at wavelength  $\lambda = 664 \text{ nm} - D_{664}$ . The spectrum was obtained relative to the comparison solution – water solution of  $C_{60}(OH)_{24}$  with the same concentration, that was in test suspension without fullereneol (fullereneol was not consumed during the growth of Chlorella). All suspensions before turbidimetric determination were thoroughly shaken.

From Figure 1 one can see, that at the time of exposition 1 day (2, 3 also) fullereneol has an effect, inhibiting=protecting the process of chlorella depopulation, and after that - at times 2~3 - 9 days fullereneol starts catalyze=accelerate the process of chlorella depopulation. At the same time positive fullereneol inhibitory activity at the first days according to the absolute value 1-2 order is stronger than negative fullereneol catalyst activity at the last days. Maximal positive fullereneol inhibitory activity corresponds to  $C_{\text{fullereneol}} \approx 0.1 \text{ g/dm}^3$ . With further increase common catalyst or inhibitory activities both quickly decreasing.



**Figure 1.** Dependencies of the differential catalyst fullereneol activities of the process against fullereneol concentrations at different observation time (in days): 1-st (left); 4-th (right: triangles with base on left); 9-th (right: stars).

### References

- [1] Pochkaeva E. I., Podolsky N.E., Zakusilo D.N., Petrov A.V., Charykov N.A., Vlasov T.D., Penkova A.V., Vasina L.V., Murin I.V., Sharoyko V.V., Semenov K.N. *Fullerene derivatives with amino acids, peptides and proteins: From synthesis to biomedical application* **2020**, 57, 100255.
- [2] Shevchenko S.D., Rakhimova O.V., Charykov N.A., Semenov K.N., Keskinov V.A., Vorobiev A.L., Kulenova N.A., Onalbaeva Zh. S. *Synthesis, identification and biotesting of water soluble octo-adduct of fullerene C60 and arginine C60(C6H12NaN4O2)8H8.* **2018**, 77-81.

## NEW GADOLINIUM-BASED CONTRAST AGENT: PROSPECTS AND APPLICATIONS

*Matsenko R.O., Glavinskaia V.O., Zheltova V.V., Osmolowsky M.G., Bobrysheva N.P., Osmolovskaya O.M.*

Saint Petersburg State University, Saint Petersburg, Russia  
vladaglavinskaia@mail.ru

Magnetic resonance imaging is a modern non-invasive and radiation-free method of visualization of internal organs for the prediction and diagnosis of diseases. For better visualization, contrast agents are used. Today, the only permitted contrast agents are gadolinium-based compounds, such as Omniscan, and others. Gadolinium has a pronounced contrasting effect, but a free gadolinium ion is toxic and entails serious side effects in the organism.

Hydroxyapatite is the main inorganic component of bone tissue, biocompatible and suitable for medical use, so we suggest to use gadolinium-doped nanoparticles of hydroxyapatite as a contrast agent.

The simplest and most cost-effective methods of synthesis of this material are precipitation and hydrothermal treatment, which allow the dopant to enter the crystal lattice of the matrix without the formation of additional phases. These methods were used in the work.

The morphological parameters and surface composition of the obtained samples were studied by XRD, TEM, and IR spectroscopy, specific surface area was determined. It was shown that depending on the concentration of the initial reagents and the used synthesis method, gadolinium-doped hydroxyapatite nanoparticles are formed rod-shaped with sizes from 12 to 33 nm in thickness and from 34 to 81 nm in length.

The exposure of a preliminary prepared suspension of nanoparticles at an elevated temperature leads to the orientation attachment of the particles due to the interaction of the initial nanoparticles with each other. In this case, larger particles are formed. The parameters of the "initial" nanoparticles depend on the concentration of the initial reagents in the reaction medium, and the "final" nanoparticles depend on the holding temperature.

The imaging capabilities of gadolinium-doped hydroxyapatite nanoparticles in agarose gel were also studied. In all samples, an increase of contrast with respect to pure agarose was observed. This indicates that the obtained material increase contrast and can be used in MRI. The results of the studies showed that the relaxation times T1 and T2 increase with the increase in the size of the nanoparticles. The relaxation times, signal intensity, and image contrast are comparable to the data obtained earlier in the study of magnetite [1].

### References

[1] Zheltova V., Vlasova A., Bobrysheva N., Abdullin I., Semenov V., Osmolowsky M., Voznesenskiy M., Osmolovskaya O. *Applied Surface Science*. 2020, 531, 147352.

Acknowledgements. Scientific research was performed using the equipment of the Research Park of St. Petersburg State University (Centre for X-ray Diffraction Studies, Chemical Analysis and Materials Research Centre, Centre for Innovative Technologies of Composite Nanomaterials, Centre for Optical and Laser Materials Research, Centre for Magnetic Resonance).

## A NOVEL METHOD FOR PRODUCING CELLULOSE NANOPARTICLES AND THEIR POSSIBLE APPLICATIONS

*Gorbacheva S.N., Yadykova A.Y., Ilyin S.O.*

A.V. Topchiev Institute of Petrochemical Synthesis, Russian Academy of Sciences  
PhD student

[svetlana.gorbacheva.1994@mail.ru](mailto:svetlana.gorbacheva.1994@mail.ru)

In recent decades, investigations aimed to the obtaining eco-friendly and renewable materials have attracted an increasing attention. Cellulose that has such properties as biodegradability, non-toxicity, and a good chemical resistance could be a great raw base to produce green materials. Moreover, agricultural and industrial activities generate a large amount of cellulose-containing waste that practically always is being unclaimed due to cellulose infusibility and insolubility at least in all easy-available organic solvents. One of the ways to solve the problem of rational utilization of cellulose waste can be obtaining nanocellulose with its further using in industry.

In this research, a new approach to produce cellulose nanoparticles by a precipitant-induced phase separation of cellulosic solution was proposed. This approach included cellulose dissolution in a mixed solvent consisting *N*-methylmorpholine *N*-oxide and dimethyl sulfoxide with subsequent regeneration of cellulose under the influence of alkalized water and ultrasound. As a result, nanocellulose was obtained with low degree of crystallinity and good ability to thicken water and polar liquids: its 0.1-0.5% dispersions had a quiet high both effective viscosity and yield stress.

Obtained cellulose nanoparticles were used for two purposes. Firstly, nanocellulose was used to emulsifier heavy crude oil in water to decrease its high viscosity. Secondly, nanocellulose was applied as a thickener to produce novel biodegradable low-temperature greases. In both cases, the rheological behavior of aqueous dispersions of nanocellulose was decisive. The effect of nanocellulose concentration on the properties of dispersions and the ability of their application for above-mentioned purposes were investigated. As a result, both greases with high antiwear properties and stable oil-in-water emulsions, which allowed decreasing the viscosity of heavy crude oil in 13 times, were obtained and examined.

Acknowledgements. This work was supported by the Russian Science Foundation (project No 19-79-10283).

## QUANTUM DOTS FOR CREATING LASER-ACTIVE ENVIRONMENT

*Gorbunov I.S., Stepanova U.A., Al-Mayyahi H.A., Muradova A.G.*

Russian University of Chemical Technology, Department of Nanomaterials and Nanotechnology,  
Moscow, Russia  
[iamivangorbunov@gmail.com](mailto:iamivangorbunov@gmail.com)

One of the key problems in optoelectronics is the creation of laser-activated media with variable emission frequencies [1,2]. Polymeric media activated by semiconductor and perovskite quantum dots can be a solution to this problem. Cadmium selenide nanocrystals are the most widely used because they can fluoresce in the entire visible spectrum [3]. Among perovskite quantum dots, CsPbX<sub>3</sub> (X=Cl, Br, I) type nanocrystals are common. In this work, the main method of obtaining semiconductor quantum dots was the deposition method. This type of synthesis is quite simple, does not require the creation of an inert atmosphere, and the process temperature does not exceed 200 °C. The method for producing perovskite quantum dots was the hot injection method.

Colloidal solutions of cadmium selenide quantum dots in water-ethanol medium, in diethylene glycol and glycerol with sizes from 1.8 nm to 4.5 nm, which are capable of luminescence from 521 nm to 630 nm were obtained. The quantum yield of luminescence increases from 3.5% to 20% when a shell of cadmium sulfide (CdS) is applied to the core. We obtained CsPbX<sub>3</sub>-type perovskite nanocrystals with a luminescence spectrum from 400 nm to 650 nm. The advantages and disadvantages of semiconductor and perovskite quantum dots for the development of laser-active media based on them were investigated.



**Figure 1** CdSe and CdSe/CdS CTs in daylight and in UV 365 nm.

### References

- [1] Durán-Sampedro G., Agarrabeitia A.R., Garcia-Moreno I., Costela A., Bañuelos J., Arbeloa T., López-Arbeloa I., Chiara J.L., Ortiz M.J. Chlorinated BODIPYs: Surprisingly Efficient and Highly Photostable Laser Dyes. *European Journal of Organic Chemistry*. 2012. V. 2012. N 32. P. 6335-6350. DOI: 10.1002/ejoc.201200946.
- [2] Garcia-Moreno I., Costela A., Martin V., Pintado-Sierra M., Sastre R. Materials for a reliable solid-state dye laser at the red spectral edge. *Adv. Funct. Mater.* 2009. V. 19. N 16. P. 2547-2552. DOI: 10.1002/adfm.200900112.
- [3] Saidzhonov B.M., Zaytsev V.B., Berekchiian M.V., Vasiliev R.B. Highly luminescent copper-doped ultrathin CdSe nanoplatelets for white-light generation. *Journal of Luminescence*. 2020. V. 222. 117134. DOI: 10.1016/j.jlumin.2020.117134.



# A SENSOR BASED ON TITANIUM DIOXIDE GEL FOR THE DETERMINATION OF HYDROGEN PEROXIDE IN THE DAIRY PRODUCTS

*Gritsenko M.M.*<sup>1</sup>, *Nazarova E.A.*<sup>2</sup>, *Krivoshapkina E.F.*<sup>3</sup>

<sup>1,2,3</sup>ITMO University, Saint Petersburg, Russia  
Student  
[gritsenko@scamt-itmo.ru](mailto:gritsenko@scamt-itmo.ru)

Raw milk preservation remains a challenge for the modern dairy industry. Some of producers add hydrogen peroxide into the milk to prolong its shelf life and activate lactoperoxidase system. The antimicrobial activity of lactoperoxidase contained in milk is manifested through the catalytic oxidation of thiocyanate ion (SCN<sup>-</sup>) with hydrogen peroxide. Lactoperoxidase is a heme-containing glycoprotein found in milk, saliva, lacrimal fluid, and the mucous membrane of the respiratory tract. Its function is to use H<sub>2</sub>O<sub>2</sub> to form hypothiocyanate (OSCN<sup>-</sup>). The resulting hypothiocyanate is able to suppress bacteria, fungi, parasites, viruses, ensures the destruction of intestinal pathogens in the infant, and protects the mammary glands and breast milk. However, the hydrogen peroxide excess in food products leads to negative health effects, so the residual amount of added peroxide should be controlled. Accidental contamination of dairy products with hydrogen peroxide, which is used as disinfectant to treat equipment and surfaces, is also possible [1]. Therefore, the possibility of developing of a solid sensor that will determine quickly and quantitatively the presence of hydrogen peroxide in milk is of great interest.

It is well known a qualitative reaction to hydrogen peroxide using titanium dioxide, producing an intense yellow color. In this reaction, titanium dioxide is formed peroxy complex with peroxide [2]. The main purpose of this research was to create uniform reproducible sensitive films based on titania nanoparticles capable of rapidly reacting with hydrogen peroxide to quantify its content. A promising method for detecting small concentrations (less than 0.01%) of hydrogen peroxide in milk by the formation of a colored complex compound of titanium dioxide with H<sub>2</sub>O<sub>2</sub> is proposed for the first time.

The sol was synthesized according to the already developed method using acidic peptization: titanium isopropoxide was mixed with isopropanol which was added dropwise to a solution of deionized water with nitric acid. Then, the solution was mixed by magnetic stirrer for 5-7 days [3]. Next, the sol was dried and the titania dioxide gel was obtained using xerosol. The sensitivity of TiO<sub>2</sub> was tested at hydrogen peroxide concentrations of 0.5%, 0.1%, 0.05%, 0.01%, 0.005%, 0.001% in aqueous solutions. During the reaction, all samples became colored from bright orange to pale yellow, and color intensity was measured by spectrophotometry. Therefore, this method can be used to determine small concentrations of hydrogen peroxide. In addition, milk solutions with hydrogen peroxide were also tested on the films from this series. The color remained stable after drying.

Thus, during the work, a titanium dioxide sol was synthesized; homogeneous and transparent films were obtained from xerosol. The dependencies between the color intensity and the concentration of hydrogen peroxide in the samples were found. At this stage, the creation of a sensor based on titanium dioxide gel by inkjet printing and 3D printing is promising for this process automatization. It is possible to use this method to determine low concentrations of hydrogen peroxide in milk. The further prospects of the project are the development and creation of a sensor system based on the hardware platform of electronic devices.

## References

- [1] Takele B., Abdulkaf K., Tariku J., Fanos T., Dinka A. et al. *J. Nutr. Food Sci.* **2015**, S13:003.
- [2] Gökdere B., Üzer A., Durmazel S., Erçağ E., & Apak R. *Talanta* **2019**, *202*, 402–410.
- [3] Safaryan S. M., Yakovlev A. V., Vinogradov A. V., & Vinogradov V. V. *Sens. Actuators B Chem.* **2017**, *251*, 746–752.

Acknowledgements. This work was supported by the Council on grants of the President of the Russian Federation (Project No. MK-1632.2020.11).

PHOTOCATALYTIC ACTIVITY OF BUTYLAMINE-INTERCALATED PEROVSKITE-LIKE  
LAYERED OXIDE  $\text{H}_2\text{La}_2\text{Ti}_3\text{O}_{10}$

Gruzdeva E.O., Rodionov I.A.

Saint Petersburg State University, Saint Petersburg, Russia

Student

[katerinagruzdeva@mail.ru](mailto:katerinagruzdeva@mail.ru)

Layered perovskite-like oxides are complex compounds in which layers with a perovskite structure alternate with layers with different structures. Layered oxides are attractive objects of study due to the peculiarities of their structure and several unique properties, particularly the ability to intercalate molecules into the interlayer space, ion-exchange reactions, and to delamination into the nanolayers. These properties not only determine the high photocatalytic activity of some representatives of this class of compounds but also open up many possibilities for their modification, for example, for the creation of hybrid and composite photocatalysts. [1, 2]

The present research considers the photocatalytic activity of the triple-layered perovskite-like titanate  $\text{H}_2\text{La}_2\text{Ti}_3\text{O}_{10}$ , intercalated with *n*-butylamine, in the reaction of hydrogen production from an aqueous methanol solution. Effects of alcohol concentration, catalyst amount, platinum loading, pH of suspension and temperature on the photocatalytic efficiency were investigated. It was shown, that the reaction rate gradually increases almost 10 times when the solution pH is changed from basic (pH = 12) to acidic (pH = 2). The dependence of the hydrogen evolution rate on the concentration of methanol, the loading of platinum and the amount of catalyst all demonstrate a maximum, while the change of temperature has almost no effect on the reaction rate. An apparent quantum efficiency of 44% was observed under optimal conditions.

Characterization of the photocatalyst after the photocatalytic experiment was performed using X-ray diffraction, NMR spectroscopy, thermogravimetry, elemental CHN-analysis and SEM with an emphasis on its structure, composition, thermal stability and morphology. It was found that the intercalated *n*-butylamine undergoes complete destruction during the photocatalytic experiment, that results in the decrease of the interlayer distance. The main products of butylamine and methanol transformations (butanal, formaldehyde, formic acid, methenamine...) were detected in the reaction solution by means of GC-MS. However, surprisingly, the photocatalytic performance remains high and stable (TON > 100) even in the absence of *n*-butylamine, many times exceeding that for the initial  $\text{H}_2\text{La}_2\text{Ti}_3\text{O}_{10}$ . The reason for such behavior is still unclear and is under discussion.

#### References

- [1] I. A. Rodionov and I. A. Zvereva // Russ. Chem. Rev., V. 85, N. 3, P. 248, **2016**.  
[2] I. Rodionov, E. Maksimova, A. Pozhidaev, S. Kurnosenko, O. Silyukov, I. Zvereva // Front. Chem., 7, Art. 863. **2019**.

Acknowledgements. This work was supported by the Russian Science Foundation (project No 19-13-00184).

Authors are also grateful to Saint Petersburg State University Research Park: Center for X-ray Diffraction Studies, Center for Thermal Analysis and Calorimetry, Center for Chemical Analysis and Materials Research, Interdisciplinary Center for Nanotechnology, Magnetic Resonance Research Centre.

PRECISE GRAFTING OF THE KEPLERATE POLYOXOMETALATES BY ORGANOSILICONE FOR DYES CONJUGATION

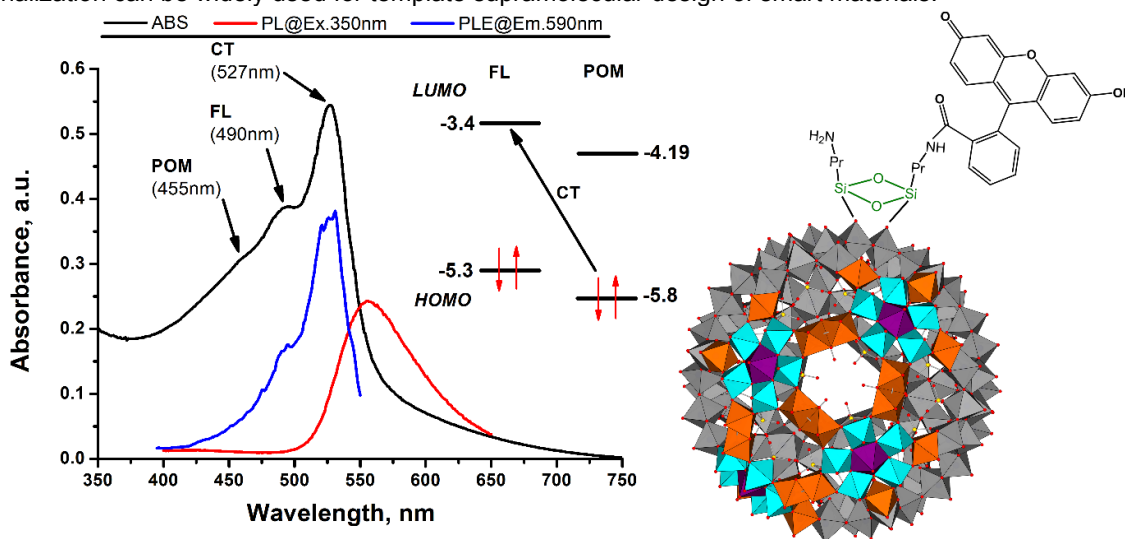
*Grzhegorzhevski K.V., Denikaev A.D., Morozova M.V., Priakhina V.I.*

Ural Federal University named after B.N. Yeltsin, Ekaterinburg, Russia  
Young Scientist  
kirillvalentinovich@urfu.ru

The covalent modification of simple (Keggin, Anderson-Evans etc.) polyoxometalates (POM) with different alkoxyislanes is well known and widely used in smart-materials design. However, the interaction of alkoxyislanes with nanoscaled giant POM is still challenged. Giant polyoxometalates, consisted of more than hundred metal atoms ( $\text{Mo}_{132}$ ,  $\text{Mo}_{154}$ ,  $\text{Mo}_{365}$  etc. [1]), are precise nanoscale objects filling the gap between molecules and nanoparticles. Reaching several nanometers (2.5-3.6 nm) in size, with different highly symmetric shapes (Keplerate, toroidal, lemon-like) the POMs can be used as template for supramolecular design of functional materials [2].

In current work we studied a covalent functionalization of giant Keplerate  $\text{Mo}_{132} = (\text{NH}_4)_{42}[\text{Mo}^{\text{VI}}_{72}\text{Mo}^{\text{V}}_{60}\text{O}_{372}(\text{CH}_3\text{COO})_{30}(\text{H}_2\text{O})_{72}] \cdot (\sim 300\text{H}_2\text{O}) \cdot (\sim 10\text{CH}_3\text{COONH}_4)$  with organosilane APTMS (3-aminopropyltrimethoxysilane) for the first time. The motivation of this investigation was to find the simple and flexible approach to conjugate giant POM with organic molecules in pre- or post-modification scenarios. Instead of well-known diol and triol ligands using for functionalization of simple POM (such as Anderson-Evans types) under refluxing conditions [3], we paid our attention on organosilicones, which should facile react with nanocluster surface terminated by hydroxyl groups and aqua-ligands under smooth conditions.

Using of IR spectroscopy showed the linear correlation with POM's grafting degree for key bands:  $1047\text{ cm}^{-1}$   $\nu(\text{Si-O-Si})$ ,  $1117\text{ cm}^{-1}$   $\nu(\text{Si-O}_2\text{-Si})$ ,  $1209/1151\text{ cm}^{-1}$   $\nu(\text{Si-O-CH}_3)$ . Raman spectra confirmed the integrity of POM structure and the interaction of APTMS with terminal oxygen atoms on the  $\text{Mo}_{132}$  surface. In accordance with XPS data and elemental analysis (Mo, Si) we created a model for reaction mechanism between  $\text{Mo}_{132}$  and APTMS in methanol and toluene solution where the found ligands exchange process play an important role. In addition, by means of SEM we found formation of nanostrips from  $\text{Mo}_{132}$ -APTMS conjugates. Furthermore, obtained product  $\text{Mo}_{132}@18\text{APTMS}$  has been functionalized with NHS-fluorescein in acetonitrile to produce novel conjugate with charge transfer band (Fig. 1). As a result, our pioneer approach to POM covalent functionalization can be widely used for template supramolecular design of smart materials.



**Figure 1.** The charge transfer (CT) band's appearance in UV-Vis (ABS), photoluminescence (PL) and photoluminescence excitation (PLE) spectra (left side). The POM in polyhedral representation with grafted fluorescein (FL) molecule (right side).

#### References

- [1] P. Gouzerh, M. Che, *Actual. Chim.* **2006**, 298, 9–22.
- [2] V. Fazylova, N. Shevtsev, S. Mikhailov, G. Kim, A. Ostroushko, K. Grzhegorzhevskii, *Chem. – A Eur. J.* **2020**, 26, 5685–5693.
- [3] J. Zhang, Y. Huang, G. Li, Y. Wei, *Coord. Chem. Rev.* **2019**, 378, 395–414.

Acknowledgements. This work was supported by the Russian Science Foundation (project No 19-73-00177).

# PLANAR COMPOSITE MATERIALS BASED ON GRAPHENE OXIDE AND POLYDIACETYLENE DERIVATIVES

*Gusarova E.A.<sup>1,2</sup>, Zvyagina A.I.<sup>2</sup>, Kuzmina N.V.<sup>2</sup>, Alexandrov A.E.<sup>2</sup>,  
Averin A.A.<sup>2</sup>, Kalinina M.A.<sup>2</sup>*

<sup>1</sup>Moscow State University, Moscow, Russia

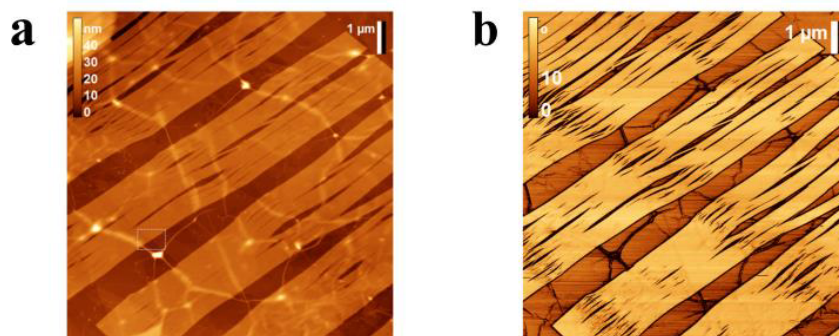
<sup>2</sup>A.N. Frumkin Institute of Physical chemistry and Electrochemistry RAS, Moscow, Russia  
Student

[liisagus@mail.ru](mailto:liisagus@mail.ru)

Graphene-based materials are now widely used in electronics and solar cells due to their large specific surface area, optical transparency, high mechanical strength, and excellent electrical conductivity. Of particular interest are conductive elements based on reduced graphene oxide (rGO), which is obtained from cheap and easy-to-obtain graphene oxide (GO) by chemical or thermal reduction. However, the structure of rGO contains a large number of defects, which negatively affects the conductive characteristics of the material. In this work, we propose to "heal" these defects using a polymer of 10,12-pentacosadiynoic acid (PDA) to increase the conductive characteristics of rGO coatings.

We have previously shown that GO can spontaneously form adsorption layers at the water/oil interface due to the presence of hydrophilic and hydrophobic regions.[1] In this work, the organic phase was replaced by a thin layer of PDA solution in hexane, which did not affect the ability of GO to adsorb at the interface. To obtain ultrathin PDA/rGO coatings, a silicon or quartz substrate was dipped into an GO hydrosol. Then we poured a layer of PDA in hexane on top, waited for a while and lifted the substrate with a low speed. The obtained PDA/rGO composites were subjected to UV irradiation for PDA polymerization and subsequent microwave heating to reduce GO. The presence of both components in the obtained films is confirmed by the presence of characteristic bands of PDA and rGO in the absorption spectra. The uniformity of the PDA distribution over the rGO surface is confirmed by SEM images and mapping using Raman spectroscopy. According to atomic force microscopy, the thickness of such coatings is about 10 nm. AFM images show that the polymer overlaps the rGO sheets, thereby "healing" defects in the monolayer and reducing the sheet resistance (Fig. 1). According to the results of measurements of the conductivity, an increase in the electrically conductive characteristics of the PDA/rGO composites was demonstrated by a factor of 6.5 compared to the conductivity of the rGO monolayers. The obtained value of the electrical conductivity of the PDA/rGO composite was 46 S•cm<sup>-1</sup>. The composite exhibits the properties of a diode when integrated into the ITO/ rGO+PDA/ C60 / LiF / Al system due to the ability of the PDA to absorb visible light and the presence of electron transfer between the PDA and the rGO.

So, in this work, we have developed a new method for obtaining ultrathin electrically conductive composite materials based on graphene oxide and 10,12-pentacosadiynoic acid by transferring from the interface to solid substrates at room temperature. The totality of the obtained properties makes such systems promising objects for organic electronics. Also, the developed approach makes it possible to replace PDA with other oligomeric surfactants to vary the properties of composites in a wide range.



**Figure 1.** AFM-image of PDA/rGO thin film: a) topography b) phase contrast

## References

[1] Zvyagina A. I. et al. Fabrication of uniform monolayers of graphene oxide on solid surfaces //Surface Innovations. – 2019. – T. 7. – №. 3–4. – C. 210-218.

Acknowledgements. This work was supported by the Russian Science Foundation (project № 20-13-00279)

Guselnikova O.<sup>1,2</sup>, Postnikov P. S.<sup>1,2</sup>, Lyutakov O.<sup>2</sup>

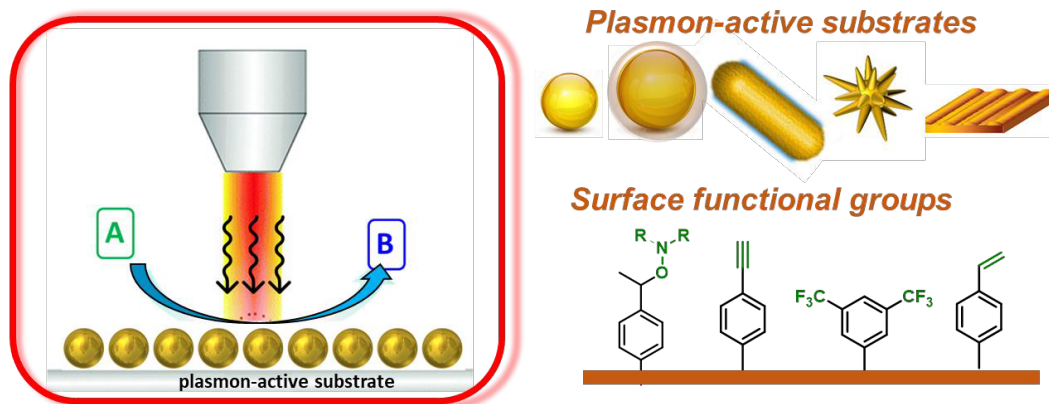
<sup>1</sup>Tomsk Polytechnic University, Tomsk, Russia

<sup>2</sup>University of Chemistry and Technology Prague, Prague, Czech Republic

[guselnikovaoa@tpu.ru](mailto:guselnikovaoa@tpu.ru)

Recently, the utilization of plasmon assistance was demonstrated to be a useful tool for promoting various chemical transformations, where existing limitations of heterogeneous catalysis, such as high temperature and pressure and utilization of an elaborated catalyst, can be overcome [1]. During the illumination of the plasmonic substrates, localized plasmon resonance or surface plasmon-polariton plasmon resonance are excited to interact with adsorbed/covalently attached organic molecules leading to the chemical transformations. Therefore, through the diversity of factors affecting these transformations, substrate structure and surface chemistry are one of the key factors.

In the framework of our group, we performed a series of works that describe the effect of plasmon-active substrates (bimetallic and anisotropic surfaces), and surface chemistry (surface attached co-catalyst, initiators). We demonstrated that the thickness of precious layer and illumination mode (continuous or pulsed) affect the selectivity of hydrogenation for acetylene and nitro-compounds [2,3]; the selective excitation of anisotropic nanoparticles lead to the selective grafting of functional groups [4]. Simultaneously, we demonstrated that often the surface-attached functional groups play a key role and could initiate the polymerization [5], growth of covalent organic framework [6], azide-alkyne cycloaddition [7] and CO<sub>2</sub> cycloaddition [8].



**Figure 1.** Schematical illustration of plasmon-induced catalysis and discussed in the report factors

### References

- [1] Zhenglong Zh., Chengyun Zh., Hairong Zh., Hongxing X., *Acc. Chem. Res.* 2019, 52, 9, 2506–2515
- [2] Erzina, M., Guselnikova, O., Miliutina, E., Trelin, A., Postnikov, P., Svorcik, V., Lyutakov O., Plasmon-Assisted Transfer Hydrogenation: Kinetic Control of Reaction Chemoselectivity through a Light Illumination Mode, *Journal of Physical Chemistry C*, **2021**, 125, 19, 10318–10325
- [3] Guselnikova O., Olshtram A., Kalachyova, Y. Panov, I., Postnikov, P. Svorcik, V., Lyutakov, O., *J. Phys. Chem. C*, **2018**, 122 (46), 26613–26622.
- [4] Olshtram, A., Guselnikova, O., Postnikov, P., Trelin, A., Yusubov, M., Kalachyova, Y., Lapcak, L., Cieslar, M., Ulbrich, P., Svorcik, V. and Lyutakov, O., *Nanoscale*, **2020**, 12(27), 14581-14588
- [5] O. Guselnikova, S. Marque, E. Tretyakov, D. Mares, V. Jerabek, G. Audran, J.-P. Joly, M. Trusova, V. Svorcik, O. Lyutakov, P. Postnikov, *J. Mater. Chem. A*, **2019**, 7, 12414-12419.
- [6] Guselnikova, O., Kalachyova, Y., Elashnikov, R., Cieslar, M., Kolska, Z., Sajdl, P., Postnikov, P., Svorcik, V. and Lyutakov, O., *Microporous and Mesoporous Materials*, **2020**, 309, 110577.
- [7] Guselnikova, O., Váňa, J., Phuong, L.T., Panov, I., Rulíšek, L., Trelin, A., Postnikov, P., Švorčík, V., Andris, E. and Lyutakov, O., *Chemical Science*, **2021**, 12, 5591-5598
- [8] Guselnikova, O., Postnikov, P., Kosina, J., Kolska, Z., Trelin, A., Svorcik, V. and Lyutakov, O., *Journal of Materials Chemistry A*, **2021**, 9(13), 8462-8469.

Acknowledgements. This work was supported by the Russian Science Foundation (project № 20-73-00151).

# SYNTHESIS AND CHARACTERIZATION OF MESOPOROUS SILICA NANOPARTICLES

*Gutsalova A.A, Vinogradov A.V.*

SCAMT Institute, ITMO University, Saint Petersburg, Russia  
Student  
gutsalova@scamt-itmo.ru

Mesoporous materials with high specific surface area, pores volume and unique pore size are currently intensively studied as they are promising carriers for controlled bio-active delivery [1]. Generally, mesoporous silicon dioxide nanomaterials are considered to be biocompatible with minimal non-specific or side effects. However, the biocompatibility of silica depends on several factors, such as the particle size, shape, and surface chemical composition. Particle sizes can influence silica biological parameters involving distribution, duration of circulation, and rate of excretion. The silica nanoparticles with a smaller size have a longer blood circulation lifetime [2]. The removal of mesoporous silicon dioxide nanoparticles by urine grows with the increasing particle size, which affects the decomposition rate and biocompatibility [3]. The large surface area of mesoporous silicon dioxide nanoparticles allows them to carry a larger amount of the desired drug compared with traditional methods including polymers, liposomes, and vesicles [4]. Additionally, silica particle surfaces can be easily modified with hundreds of available silanes to control chemistry surface, drug loading, solvent compatibility, stability, as well as to provide specific biological targeting. The main advantages of silicon dioxide nanoparticles are their high biocompatibility, thermal stability, low cost, low toxicity, and easy surface modification. In BET this regard, silica nanoparticles are a useful tool for delivering biologically active substances of various chemical nature directly to the place where they are required in the patient's body.

The literature data analysis showed the possibility of obtaining various innovative drug delivery systems based on silica nanoparticles. We have synthesized nanoparticles according to the method described in the paper [5]. The surface morphology of the nanoparticles was observed using scanning electron microscopy (SEM) on FEI Quanta 200. The surface area, pore volume, and pore size distribution were investigated using Quantachrome Nova 1200e by nitrogen adsorption at 77 K and analyzed using the Brunauer–Emmett–Teller (BET) and Barrett-Joyner-Halenda (BJH) equations. Prior to analysis, all samples were degassed at 200 °C for 24 hours. Zeta potential was measured using Photocor Compact-Z analyzer.

To study the size and morphology of the synthesized nanoparticles, we took SEM images, which demonstrate spherical nanoparticles with a diameter of about 50 nm and a narrow size distribution. The dynamic light scattering (DLS) measurements of the nanoparticles confirm these results and show small agglomerates of nanoparticles. The mesoporosity was quantified by nitrogen sorption measurements. The BET surface area was calculated from the isotherms amounts to 977 m<sup>2</sup> g<sup>-1</sup> for the unmodified nanoparticles. The pore volume is 1.0 cm<sup>3</sup> g<sup>-1</sup>. Nanoparticles exhibit a pore size diameter of about 3 nm, which was determined by the BJH method based on the adsorption data. To analyze the mesoporous silica nanoparticles, DLS measurements were performed in aqueous suspensions. A particle size is approximately 85 nm with the distribution ranging from 60 to 110 nm. Thus, the measurements indicate that particle sizes are slightly larger compared to those observed in the SEM images. This can be explained with the fact that DLS measurements give the hydrodynamic radii of the particles. Moreover, a minor tendency of the particles to agglomerate may contribute, corresponding to the observation that a solid precipitated from the suspensions after several minutes of settling. The nanoparticles exhibit a negative zeta potential of -30 mV.

Mesoporous silicon dioxide nanoparticles promise as a prospective biomaterial in medical applications. Mesoporous silicon dioxide nanoparticles can be used for transporting therapeutic drugs and encapsulating molecules due to their biocompatibility, high load capacity and ability to attach target ligands for specific cellular recognition, the construction of a well-defined and configurable porosity [6]. In many studies nanomaterials based on silica demonstrate a high degree of loading for various drugs, which provides new opportunities for their introduction in clinical practice.

## References

- [1] Hudson, S. P., Padera, R. F., Langer, R., and Kohane, D. S. The biocompatibility of mesoporous silicates. *Biomaterials* **2008**, 29, 4045–4055
- [2] Huang, X., Li, L., Liu, T., Hao, N., Liu, H., Chen, D., et al. The shape effect of mesoporous silica nanoparticles on biodistribution, clearance, and biocompatibility in vivo. *ACS Nano* **2011**, 5, 5390–5399
- [3] He, Q., Zhang, Z., Gao, Y., Shi, J., and Li, Y. Intracellular localization and cytotoxicity of spherical mesoporous silica nano- and microparticles. *Small* **2009**, 5, 2722–2729
- [4] Huang, X., Young, N. P., and Townley, H. E. Characterization and comparison of mesoporous silica particles for optimized drug delivery. *Nanomater. Nanotechnol.* **2014**, 4, 58290
- [5] Qiao Z-A, Zhang L, Guo M, Liu Y, Huo Q. Synthesis of Mesoporous Silica Nanoparticles via Controlled Hydrolysis and Condensation of Silicon Alkoxide. *Chem Mater* **2009**, 21, 3823–3829
- [6] Möller, K., and Bein, T. Degradable drug carriers: vanishing mesoporous silica nanoparticles. *Chem. Mater.* **2019**, 31, 4364–437

Acknowledgements. This work was supported by the Russian Science Foundation (project No 19-19-00433).

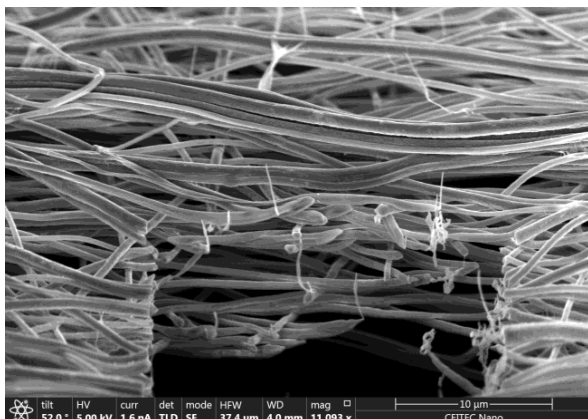
# PIEZOCATALYTIC DECOMPOSITION OF METHYLENE BLUE BY FLEXIBLE CTAB/PVDF NANOCOMPOSITE FIBERS FILM

*Gulakhmedov R.R.<sup>1</sup>, Selimov D.A.<sup>1</sup>, Abdurakhmanov M.G.<sup>1</sup>, Kadiev M.V.<sup>1</sup>, Shuaibov A.O.<sup>1</sup>, Orudzhev F.F.<sup>1</sup>, Sobola D.S.<sup>1</sup>, Ramazanov Sh.M.<sup>1</sup>*

<sup>1</sup>Dagestan State University, Makhachkala, Russia

Student

[ff.orudzhev@dgu.ru](mailto:ff.orudzhev@dgu.ru)



**Figure 1.** SEM image of CTAB/PVDF nanocomposite fibers film

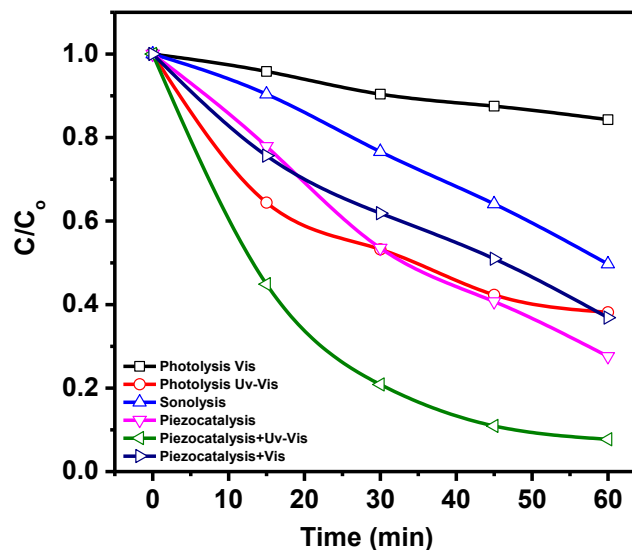
about 25 μm. The diameter of nanowires varies from 200 to 400 nm. It is seen that the surface of nanowires is smooth, uniform, and free of visible defects. It can be seen from the lamella that the structure of the film is uniform throughout its thickness. The study of the structure by XRD, Raman, XPS, FTIR methods showed that the addition of CTAB promotes an increase in the proportion of the electroactive phase of PVDF. The process of piezocatalytic and oxidation of methylene blue (MB) was investigated. Mechanical stress was created using an ultrasonic bath with an operating frequency of 18 kHz and a power of 250 W. The effect of UV-Vis and Visible light on piezocatalytic decomposition has been studied. Experiments to differentiate the contributions of sonolysis and photolysis have also been performed. The data are presented in figure 2.

It was found that, in piezocatalysis, the efficiency of MB decomposition in 60 minutes was 72%. With piezocatalysis with UV-Visible light, the efficiency increased significantly and amounted to 92%, while with visible light irradiation, the efficiency dropped to 65%.

This behavior indicates that, under the action of light and ultrasound, piezoelectric films can generate more photogenerated carriers, which ultimately leads to an increase in catalytic activity.

The development of technologies using alternative clean energy sources in recent years has attracted increasing interest of researchers to solve the problems of environmental pollution and energy shortages. However, the search for more efficient, environmentally friendly, biocompatible and easy-to-use materials is still relevant. Since the first report of piezocatalysis by direct conversion of mechanical energy to chemical energy in 2010 [1], a variety of inorganic piezoactive materials have been investigated as catalysts. Organic piezoelectrics is a new class of piezoelectric catalysts with many advantages for practical use. In this regard, in our study, we synthesized a composite material based on PVDF nanowires modified by CTAB.

Figure 1 shows a SEM image of a CTAB / PVDF nanocomposite fibers film obtained by electrospinning according to the technique described in our work [2]. The thickness of the resulting film was



**Figure 2.** The MB (C=1 mg/l) degradation curves. V = 20 ml, S = 3 cm<sup>2</sup>

## References

- [1] Hong, K. S., Xu, H., Konishi, H., & Li, X. Direct water splitting through vibrating piezoelectric microfibers in water. *The Journal of Physical Chemistry Letters*, **2010**, 1(6), 997-1002.
- [2] Kaspar P., Sobola D., Částková K., Knápek A., Burda D., Orudzhev F., Hadaš Z. *Polymers*, **2020**, 12(12), 2766.

## HYBRIDS BASED ON MoS<sub>2</sub> AND PYROLYTIC CARBON/CARBON NANOTUBE ARRAY FOR ANODES OF LI-ION BATTERIES

Harshavardhana S.<sup>1</sup>, Stolyarova S.G.<sup>2</sup>, Bulusheva L.G.<sup>2</sup>, Okotrub A.V.<sup>2</sup>

<sup>1</sup>Novosibirsk State University, Novosibirsk, Russia

<sup>2</sup>Nikolaev Institute of Inorganic Chemistry, Novosibirsk, Russia

Master's Student

[s.kharshavardkhana@g.nsu.ru](mailto:s.kharshavardkhana@g.nsu.ru)

Commercially available Li-ion batteries (LIB) use graphite as traditionally anode material due to low cost and high electric conductivity. However, using graphite in modern LIB is limited by low specific capacity ~372 mAh/g and the impossibility of work at high current density [1]. Transition metal dichalcogenides are investigated for applications in LIB as analogs of graphite. Layered hexagonal MoS<sub>2</sub> is the most promising candidate now due to the high theoretical capacity 670 mAh/g by lithium since has intercalation and conversion reactions when interacting with lithium [2]. However, bulk MoS<sub>2</sub> has low conductivity, mechanically and chemically degrades during cycling [3]. To eliminate these disadvantages carbon material can be used, which has good conductivity and stability of operation with repeated cycles of insertion/extraction of lithium. Carbon will increase the mechanical stability of MoS<sub>2</sub> in the intercalation process and the composite will have a higher capacity in comparison with the values for individual components. Moreover, different types of carbon materials can affect both the morphology of finished hybrids and their behavior when interacting with lithium.

In the present work, we used two strategies for the synthesis of hybrids MoS<sub>2</sub>/C, where C - pyrolytic carbon (PC) or carbon nanotubes array (CNT array). MoS<sub>2</sub>/PC was obtained by heating of previously hydrothermal synthesized MoS<sub>2</sub> at 800 °C during 10-30 minutes in ethane/argon flow. PC formed on the surface of MoS<sub>2</sub> can increase conductivity and stability during cycling of hybrids, and prevent the dissolution in the electrolyte of interaction products lithium and MoS<sub>2</sub>. Another approach is, the synthesis of MoS<sub>2</sub> on a CNT array by hydrothermal synthesis at 200°C 24 hours at different three different concentrations. For this, an array of carbon nanotubes on silicon substrates was used. The use of carbon nanotubes also increases the conductivity of the hybrid material and promotes the formation of disulfide nanoparticles, which should increase the capacity and stability of the hybrid material.

Obtained samples were characterized by X-ray diffraction techniques, XPS, Raman spectroscopy, and SEM. Hybrids MoS<sub>2</sub>/PC and MoS<sub>2</sub>/CNT and initial component were applied to nickel foam. Cells were prepared with metal lithium as a counter electrode at testing at 0.01-2.5 V and current densities from 0.05 A/g to 2 A/g. Process interaction materials were investigated with lithium by cyclic voltammetry. Comparison of cycling of samples shown that hybrids MoS<sub>2</sub>/PC synthesis during 10 minutes have a better specific capacity of 704 mAh/g at a current density of 0.05 A/g.

### References

- [1] Yumeng Shi et al., *Scientific Reports* **2013**, 3, 1
- [2] Wen Qi et al., *Journal of Materials Chemistry A* **2017**, 5, 37
- [3] Yu Ming chen et al., *Science Advances* **2016**, 2, 7

Acknowledgements. This work was supported by the Russian Foundation for Basic Research (project No 21-53-12021).



# CHARACTERIZATION OF COMMERCIAL ANIONS EXCHANGE MEMBRANES AND HOME-MADE ELECTRODES FOR IONS EXCHANGE MEMBRANES FUEL CELLS

*Ikonnikova E.V.<sup>1</sup>, Butonova S.A.<sup>1</sup>, Vinogradov A.V.<sup>1</sup>, Feina XU<sup>2</sup>*

<sup>1</sup>ITMO University, Saint Petersburg, Russia

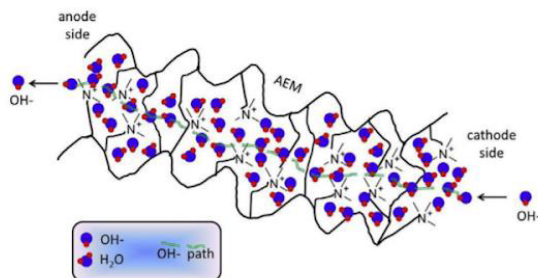
<sup>2</sup>University of Lorraine, Nancy, France

Student

[janeikonnikova@gmail.com](mailto:janeikonnikova@gmail.com)

Fuel cell is an electrochemical apparatus that the chemical energy of fuel without fuel combustion turned to electrical energy. Fuel cells provide the cleanest energy generated, since hydrogen or oxygen is used as fuel and water is produced as waste. The most common type of fuel cell for vehicle applications is the proton exchange membrane (PEM) fuel cell. However, they are still some involved issues such as high cost and degradation of catalyst and water management. Anion exchange membrane fuel cells (AEMFCs) have recently received increasing attention since in principle they allow for the use of non-precious metal catalysts that dramatically decrease the cost of the fuel cell.

The increased number of studies in the past few years indicates a growing interest in the research community, driven by the several advantages of the AEMFC technology over the currently commercialized proton exchange membrane fuel cells (PEMFCs) [2]. Although AEMFC is the mimic of PEMFC technology, the principle difference between them is the nature of their mobile ions. The AEM is the key differentiating element in the AEMFC device. However, there are three major limitations of current AEM materials: (1) hydroxide conductivities, (2) poor chemical stability, and (3) degradation of the electrolyte.



**Figure 1.** Schematic of a transport of OH<sup>-</sup> through AEM

Compare to PEM, AEMs the structure is still unknown and composed of a polymer backbone onto which functional cationic end groups are tethered (typically quaternary ammonium) (Fig.1). The most promising commercial membrane for anion exchange fuel cell is Aemion, Sustainion and Xion. Moreover, there are various problems to be solved including problems such as the electrode damage, conductivity of the membrane and reduction of ion conductivity by being exposed to the carbon dioxide.

In this work we studied the change in membrane size depending on the use of different solutions for the conversion of membrane ions. The data obtained allow to provide test in situ without mechanical damage to the membrane. Moreover, the ionic conductivity of promising commercially available membranes has been studied through Hittorf diffusion mode. In the attempt to understand in details our degradation of membranes, we have carried out a set of characterizations and tests by beginning with membrane sorption using a Dynamical Vapor Sorption (DVS) and FTIR- spectroscopy analysis. It is worth noting that we have studied various ink recipes using 40% Pt/C from Alfa Aesar and made some catalyst coating membranes (CCMs) using a commercial ultrasonic spray bench. The performance of CCMs were compared via CV curves obtained with a homemade fuel cell bench.

## References

- [1] Kamaruzzaman S. *Renewable Energy*, **2006**, 8, 719 – 727.
- [2] Dario R. Dekel. *Journal of Power Sources*, **2017**, 1–12

# SPREAD AND ADSORBED LAYERS OF FULLERENE C<sub>60</sub> AND BOVINE SERUM ALBUMIN AT THE WATER-AIR INTERFACE

*Isakov N.A.<sup>1</sup>, Noskov B.A.<sup>1</sup>*

<sup>1</sup>Saint Petersburg State University, Saint Petersburg, Russia  
Student

[st055657@student.spbu.ru](mailto:st055657@student.spbu.ru)

Studies of the interaction of fullerenes and proteins are developing fast nowadays as a result of the wide interest in medical and biological applications, in particular, in the fullerene toxicity. In spite that the fullerene/protein interactions occur mainly at cellular membranes, almost all of the obtained information on these interactions relates to bulk phases. Only very recently it has been shown that the liquid – gas interfaces accelerate the formation of protein/fullerene complexes [1]. The given study is devoted to the interactions of fullerene C<sub>60</sub> with bovine serum albumin (BSA) at the water – air interface. The surface properties of mixed BSA/C<sub>60</sub> layers were studied for the first time with the aim of elucidating of the surface structure in these systems and determination of the formation mechanism of these layers. For these purposes, the methods of the dilatational surface rheology methods [2], ellipsometry, optical and atomic force microscopies were applied. It was shown that BSA adsorption from its aqueous solution at an aqueous surface containing a spread fullerene layer leads to strong changes of the surface dilatational elasticity. The kinetic dependencies of the dynamic surface elasticity become non-monotonic as a result of the formation of a network of BSA / C<sub>60</sub> aggregates in the surface layer. The size and morphology of these aggregates differ strongly from those of the corresponding aggregates of pristine fullerene. The dependences of the dynamic dilatation elasticity of mixed spread BSA/C<sub>60</sub> layers on the surface pressure have two local maxima corresponding to the partial displacement of the protein from the proximal region of the surface layer and the collapse of the mixed layer.

## References

- [1] Bai Y., Wu X., Ouyang P., Shi M., Li Q., Maimaiti T., Lan S., Yang S.T., Chang X.L. *Environ. Sci.: Nano* **2021**, 8, 76–85  
[2] Noskov B.A., Bykov A.G., Gochev G., Lin S.-Y., Loglio G., Miller R., Milyaeva O.Y. *Adv. Colloid Interface Sci.* **2020**, 276, 102086

Acknowledgements. This work was supported by the Russian Science Foundation (project No 21-13-00039).

# INFLUENCE OF POLYSACCHARIDE TYPE ON THE STABILITY OF SEA BUCKTHORN OIL NANOEMULSIONS

*Ivanova I.O.<sup>1</sup>, Kostromicheva M.M., Voronina K.L., Koroleva M.Yu.*

<sup>1</sup>Mendeleev University of Chemical Technolgy, Moscow, Russia  
PhD student  
yana.emris@gmail.com

## Introduction:

Nanoemulsions are promising candidates for use in drug delivery [1-3]. Most medicinal compounds are hydrophobic, which leads to problems with their solubility in biological fluids and bioavailability. The use of nanoemulsions can prevent these problems and improve drug efficacy.

Carrageenans are polysaccharides extracted from red seaweed. Carrageenans are linear sulfate polymers containing D-galactose and 3,6-anhydrogalactose residues. Different types of carrageenans contain the various number of sulfate groups:  $\kappa$ -carrageenan contains one sulfate group per two units of carbohydrate residues, and  $\iota$ -carrageenan contains two sulfate groups per two units of carbohydrate residues respectively. Carrageenans possess bioactive properties, such as antioxidant, antitumor and antiviral activity. Due to their bioactive properties, carrageenans can also be used in drug delivery, tissue engineering, and biomedicine [4-5].

## Methods:

The aim of the work was to prepare and study oil-in-water nanoemulsions of sea buckthorn oil with carrageenans of various types ( $\kappa$ - and  $\iota$ -carrageenan, respectively) in different concentrations. The temperature phase inversion method was used to prepare nanoemulsions with sea buckthorn oil. The concentration of sea buckthorn oil was 25 vol%. Mixtures of Tween 80 and Span 80 were used as surfactants. The concentration of surfactants was 12.5 vol%.

## Results:

The mean droplet size in nanoemulsions without carrageenans was  $27 \pm 5$  nm. The nanoemulsions were unstable to flocculation and coalescence, and water phase separation took place within 24 h.

The effect of different types of carrageenans on the stability of sea buckthorn oil nanoemulsions was investigated. Adding  $\kappa$ -carrageenan at a concentration of 0.25-0.50 wt% increased the stability of nanoemulsions. At the concentration of  $\kappa$ -carrageenan 1 wt% and higher, nanoemulsions were resistant to aggregation and coagulation for >30 days.

If  $\iota$ -carrageenan concentration was 0.25 wt%, the rate of nanoemulsion breakdown was significantly decreased, and water phase separation took place during 14 days. At a polysaccharide concentration of 0.5 wt% and higher, the nanoemulsions were stable for >30 days.

The effect of the mixture of polysaccharides on the stability of sea buckthorn oil nanoemulsions was also studied. At a total polysaccharide concentration of 0.5 wt%, the highest stability (>30 days) was inherent in nanoemulsions with  $\kappa$ -carrageenan and  $\iota$ -carrageenan mass ratio 1:1 and 1:3. In nanoemulsions with  $\kappa$ -carrageenan and  $\iota$ -carrageenan mass ratio 3:1, the water phase separation from nanoemulsion started the next day.  $\kappa$ -Carrageenan or  $\iota$ -carrageenan gel network in the aqueous phase increased nanoemulsion stability. However, the properties of these carrageenan gels are different.  $\kappa$ -Carrageenan yields firm, brittle gel with syneresis, unlike  $\iota$ -carrageenan, which yields soft elastic gel without syneresis. Therefore, more stable nanoemulsions were produced at lower  $\iota$ -carrageenan concentrations. If the mixtures of these carrageenans were used, more stable nanoemulsions were prepared at lower  $\kappa$ -carrageenan and  $\iota$ -carrageenan mass ratios.

## Conclusion:

In this work, sea buckthorn oil nanoemulsions with a mean droplet size of about 30 nm were prepared. As results indicate,  $\iota$ -carrageenan is a more effective stabilizer of nanoemulsions than  $\kappa$ -carrageenan. The concentration of  $\kappa$ -carrageenan 1 wt% and  $\iota$ -carrageenan 0.5 wt% were enough for preparing nanoemulsions stable for a long time.

## References

- [1] *Resource-Efficient Technologies*. **2016**, 2(4), 233–239
- [2] *Mendeleev Commun.* **2015**, 25(5), 389-390
- [3] *Phys.Chem.Chem.Phys.* **2018**, 20, 10369–10377
- [4] *Carbohydr. Polym.* **2014**, 103, 1-11
- [5] *Carbohydr. Polym.* **2018**, 198, 385-400

# PREPARATION OF ULTRASMALL GOLD NANOPARTICLES IN THE PRESENT OF ADENOSINE TRIPHOSPHATE

*Ivanova N.K., Karpushkin E.A., Sergeev V.G.*

Lomonosov Moscow State University, Moscow, Russia  
PhD. Student  
n.ivanova1618@gmail.com

Adenosine triphosphate (ATP) has high affinity metal binding sites and can effectively bind with Au(III) ions via N<sub>7</sub> and C<sup>6</sup>-NH<sub>2</sub> groups [1-2], thus it is possible to use it as a stabilizer agent for metal nanoparticles (NPs). Herein we study the effect of the reducing agent used in the synthesis of AuNPs in the present of ATP on the size of the obtained gold particles.

We attempted the reduction of Au(III)-nucleoside complexes via strong reducing agent NaBH<sub>4</sub> and Na<sub>3</sub>Citr. Gold nanoparticles were prepared via two-fold excess of NaBH<sub>4</sub>; NaBH<sub>4</sub> was added 30 minutes after mixing ATP and HAuCl<sub>4</sub> solutions. After addition of reduction agent the color of the solutions quickly changed from almost colorless to dark red or red-violet, depending on the excess of nucleoside in the system. In all samples we observed the appearance of plasmon band with maximum at 528-535 nm in the electronic absorption spectra confirmed formation of AuNPs. The formation of AuNPs was also confirmed by transmission electron microscopy and EDX analysis, synthesized NPs were about 3-4 nm in size.

In case of reduction via Na<sub>3</sub>Citr we investigated a series of samples and varied Au(III):ATP molar ratios from 1:1 to 1:10. Na<sub>3</sub>Citr was added 30 minutes after mixing the components and then all samples was heated for 40 minutes, pH of the samples were 7-7.5. As a result of heating we have observed blue luminescent at the 480-485 region in all the samples, which increased with increasing excess of nucleoside. The most intense fluorescence was observed in the system at a tenfold molar excess of adenine.

We found that reduction of Au(III)-ATP complexes via sodium citrate and heating can lead to the formation of fluorescent NPs (less than 2 nm in size), and in the case of NaBH<sub>4</sub> under room temperature formation of 2-3 nm spherical AuNPs with narrow size distribution range.

## References

- [1] Sivakova S., Rowan S.J. *Chemical Society Reviews*. 2005, 34(1), 9-21
- [2] Demers L. M. et al. *Journal of the American Chemical Society*. 2002, 124(38), 11248-11249

Acknowledgements. This study was financially supported by the Russian Foundation for Basic Research (project No 20-33-90296\20).

# HYBRID NANOMATERIALS BASED ON ZINC PHTHALOCYANINE DERIVATIVES AND SINGLE WALLED CARBON NANOTUBES FOR CHEMIRESENSITIVE SENSORS

*Ivanova V.N.*<sup>1</sup>

<sup>1</sup>Russia Nikolaev Institute of Inorganic Chemistry SB RAS, Novosibirsk, Russia  
PhD Student  
vivanova@niic.nsc.ru

Hybrid materials based on carbon nanotubes (CNTs) and polyaromatic molecules such as metal phthalocyanine (MPc) derivatives are of great scientific interest due to the synergistic combination of the properties of the two components, which significantly increase the technological capabilities for their application. To obtain hybrid materials, methods of both covalent and non-covalent functionalization of CNTs with polyaromatic molecules are used. In most cases, non-covalent functionalization is the preferred approach for improving the interfacial properties of CNTs, since it does not cause a violation of the electronic structure of the initial carbon nanotubes. Organic molecules or metal complexes with organic ligands that have an expanded aromatic system, namely pyrene derivatives, porphyrins and phthalocyanines, are utilized for the functionalization of carbon nanomaterials, since they have the ability to form  $\pi$ - $\pi$ -stacking contacts between their aromatic system and the surface of nanotubes. Functionalization of CNTs makes them more soluble in organic solutions, which is important for creating homogeneous films, and leads to improved sensor characteristics, electron transport and catalytic properties. Hybrid materials based on nanotubes and phthalocyanines are widely used as active layers of chemical sensors. According to the literature, the sensor response of hybrid layers can be increased with the addition of aromatic substituents into the phthalocyanine macrocycle due to the expansion of the aromatic system and improved interaction between phthalocyanines and carbon nanotubes.

In this work, hybrid materials were obtained by non-covalent functionalization of single-walled carbon nanotubes (SWCNTs) with zinc phthalocyanine derivatives containing from 0 to 4 pyrene substituents. Obtained hybrid materials was characterized by Raman spectroscopy, SEM and ISP-AES. It was demonstrated that all hybrid exhibit 2-10 times higher sensor responses to ammonia compared to pure SWCNT. The possibility to detect  $\text{NH}_3$  in the presence of  $\text{H}_2\text{S}$ ,  $\text{CO}_2$ , VOC using hybrids sensor layers was also shown. Additionally, sensor properties were investigated at different temperatures (25-80 °C) and relative humidity (0-75%). Moreover, the effect of the amount of pyrene substituents in the phthalocyanine ring on the sensor properties of the hybrid material has been studied.

Thus, the use of the prepared hybrid structures as active layers of sensor devices leads to an increase in the sensitivity and selectivity of the layers in comparing with sensors based on SWCNTs.

# THE INTERACTION OF COPPER(II) IONS WITH DNA AND ITS INFLUENCE ON THE PREPARATION OF COPPER NANOPARTICLES

Ivanov B.M., Ivanova N.K., Karpushkin E.A.Sergeev V.G.

Lomonosov Moscow State University, Moscow, Russia

Student

[ivanovb661@yandex.ru](mailto:ivanovb661@yandex.ru)

Due to the unique structure, DNA is a convenient template for metal nanoparticles (NPs) preparation. Compared to other metal NPs, copper ones (CuNPs) have attracted great deal of attention owing to low cost. Moreover, they have shown strong catalytic [1] and antibacterial activity [2]. The application of CuNPs as sensors for the detection of  $Pb^{2+}$  and  $S^{2-}$  ions has been demonstrated [3, 4].

In this study, we investigated the interaction of dsDNA and copper(II) ions in an aqueous medium as well as the possibility of obtaining CuNPs in the presence of dsDNA using  $NH_2NH_2$  as reducing agent.

It was shown that at low concentration of copper(II), the metal ions were predominantly bound at the phosphate groups of DNA, as evidenced by slight increase in DNA melting temperature due to the double helix stabilization. The increase in the copper(II) content in the mixture led to destabilization of the DNA helical structure and its denaturation even at room temperature, which was ascribed to the introduction of copper(II) ions inside the double helix via the interaction with the nitrogenous bases of DNA.

Reduction of copper(II) was performed under the action four-fold molar excess of hydrazine. The change of the samples color to orange and the appearance of plasmon resonance band at 560–600 nm in the electronic absorption spectra confirmed the reduction of copper ions and the formation of CuNPs. In comparison with the DNA-free samples, other conditions being the same, the reduction of DNA-bound copper(II) led to the formation of smaller nanoparticles.

## References

- [1] Gawande M.B. et al. *Chemical reviews*. 2016, 116(6), 3722-3811
- [2] Keihan A. H., Veisi H., Veasi H. *Applied Organometallic Chemistry*. 2017, 31(7), e3642.
- [3] Chen J. et al. *Chemical communications*. 2012, 48(7), 1057-1059
- [4] Liu J. et al. *Analyst*. 2012, 137(23), 5502-5505

Acknowledgements. This study was financially supported by the Russian Foundation for Basic Research (project No 20-33-90296\20).

## SYNTHESIS OF IRON OXIDE NANOPARTICLES IN SILICA MATRICES

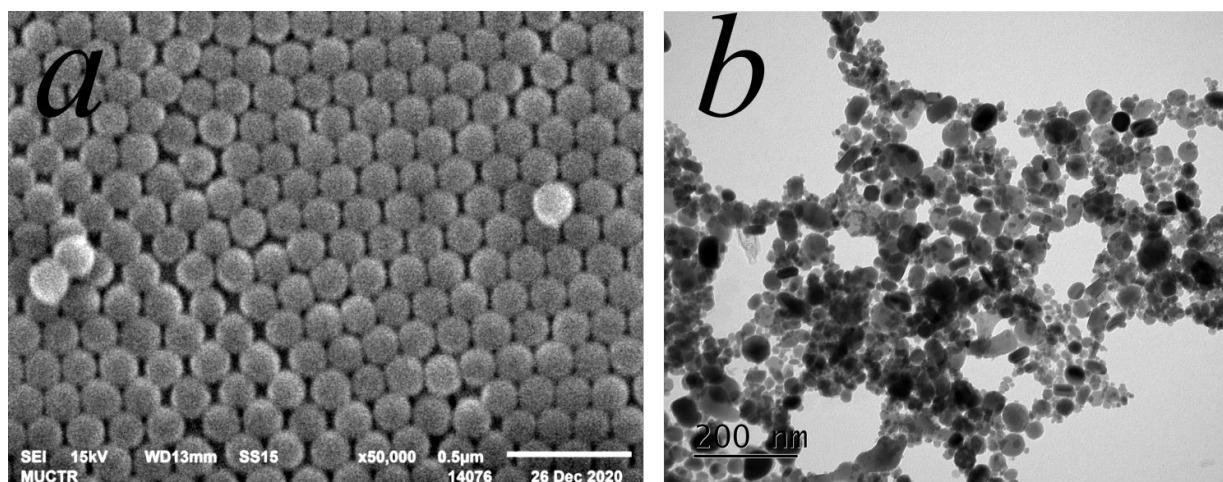
*Kagane D.D.*<sup>1</sup>, *Sharapaev A.I.*<sup>2</sup>, *Norenko A.N.*<sup>3</sup>, *Muradova A.G.*<sup>4</sup>

<sup>1</sup>Russian University of Chemical Technology, Department of Nanomaterials and Nanotechnology, Moscow, Russia

[d.kagane@yandex.ru](mailto:d.kagane@yandex.ru)

Nanomaterials based on various iron oxides play important role in science and technology. Their application depends on crystal structure and physical properties. Orthorhombic  $\epsilon$ - $\text{Fe}_2\text{O}_3$  phase takes special place because of its large coercivity ( $\sim 2$  T) [1], moderate magnetization and multiferroic properties, which make it possible to use  $\epsilon$ - $\text{Fe}_2\text{O}_3$  for microwave absorption and attenuation and as medium for magnetic recording [2]. Stability of  $\text{Fe}_2\text{O}_3$  modifications depends heavily on the size of nanocrystals [3].

It is possible to control the size of nanoparticles by template synthesis [4]. Thermal decomposition of iron (III) nitrate in confined conditions was studied in this work. Such conditions were created by voids of close packing of silicon dioxide spheres. The control of phase composition of iron oxide nanopowders is possible by tuning the size of silica nanoparticles and corresponding voids sizes. The critical sizes of  $\text{Fe}_2\text{O}_3$  nanoparticles corresponding to the  $\gamma$ - $\text{Fe}_2\text{O}_3 \rightarrow \epsilon$ - $\text{Fe}_2\text{O}_3$  and  $\epsilon$ - $\text{Fe}_2\text{O}_3 \rightarrow \alpha$ - $\text{Fe}_2\text{O}_3$  transitions were determined in this work to be  $10 \pm 2$  and  $28 \pm 3$  nm, respectively. These limits and the maximum  $\epsilon$ - $\text{Fe}_2\text{O}_3$  content is corresponding to matrices with 110 nm silica spheres. As a result, a series of nanopowders with a high content of  $\epsilon$ - $\text{Fe}_2\text{O}_3$  (up to 90%) were obtained. The high content of  $\epsilon$ - $\text{Fe}_2\text{O}_3$  phase was proved by XRD analysis and Mössbauer spectroscopy.



**Figure 1.** SEM-image of silica matrix (a) and iron oxide nanoparticles obtained in such matrix (b).

### References

- [1] Tuček J, Zbořil R, Namai A, Ohkoshi S (2010)  $\epsilon$ - $\text{Fe}_2\text{O}_3$ : An Advanced Nanomaterial Exhibiting Giant Coercive Field, Millimeter-Wave Ferromagnetic Resonance, and Magnetoelectric Coupling. *Chemistry of Materials* 22:6483–6505 . DOI: 10.1021/cm101967h
- [2] Gich M, Fina I, Morelli A, Sánchez F, Alexe M, Gàzquez J, Fontcuberta J, Roig A (2014) Multiferroic iron oxide thin films at room temperature. *Advanced Materials* 26:4645–4652 . DOI: 10.1002/adma.201400990
- [3] Lee S, Xu H (2016) Size-Dependent Phase Map and Phase Transformation Kinetics for Nanometric Iron(III) Oxides ( $\gamma \rightarrow \epsilon \rightarrow \alpha$  Pathway). *Journal of Physical Chemistry C* 120:13316–13322 . DOI: 10.1021/acs.jpcc.6b05287
- [4] Sharapaev AI, Kuznetsova SA, Norenko AN, Muradova AG, Simonenko NP, Yurtov E v. (2021) Production of  $\epsilon$ - $\text{Fe}_2\text{O}_3$  Nanoparticles in Matrices Constituted by Closely Packed Silica Spheres. *Russian Journal of Inorganic Chemistry* 66:740–746 . DOI: 10.1134/S003602362105017X

Acknowledgements. This work was supported by the Russian Foundation for Basic Research (project No 20-03-00668)

## GOLD NANOPARTICLES SYNTHESIS IN THE PRESENCE OF CARBON NANODOTS

*Karakchieva A.O., Karpushkin E.A., Sergeev V.G.*

Lomonosov Moscow State University, Moscow, Russia

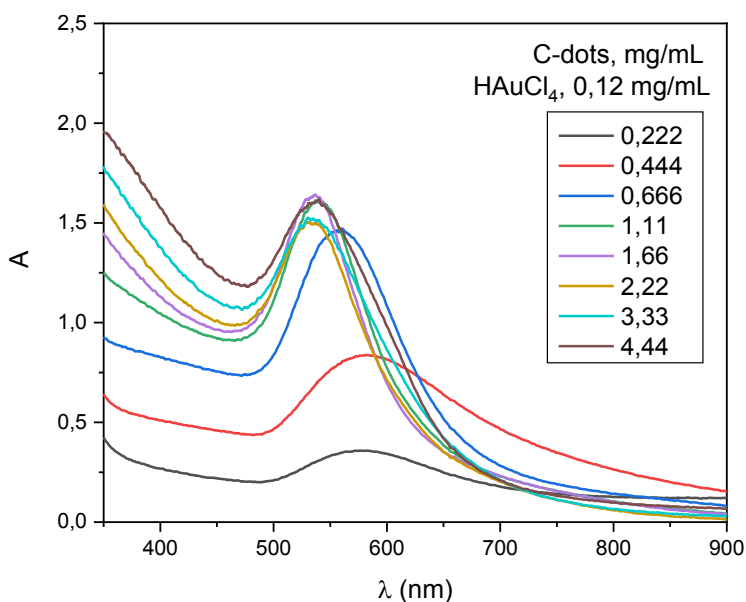
Student

[karakchievaa21@gmail.com](mailto:karakchievaa21@gmail.com)

Gold nanoparticles (Au NPs) and their assemblies are among the most studied nanomaterials, with many promising applications especially in medicine and biosensors. These are based on their peculiar optical properties, which in turn strongly depend on the nanoparticles shape and size. Therefore, development of the synthesis of Au NPs with tunable morphology is of unflagging interest. A variety of reducing and stabilizing agents for the preparation of Au NPs have been explored.

In this study, we investigated the possibility of the synthesis of Au NPs via the reduction of  $\text{HAuCl}_4$  with carbon nanodots (C-dots) – carbonaceous nanoparticles bearing hydrophilic functional groups at the surface. It was suggested that those groups could induce the reduction of Au(III) into Au(0) and stabilize the obtained Au NPs against aggregation.

We synthesized the C-dots via hydrothermal treatment of aqueous solutions of ascorbic acid, glucose, and glucosamine. Other conditions being the same, the C-dots from ascorbic acid and glucose induced rapid formation of Au NPs upon mixing with an aqueous solution of  $\text{HAuCl}_4$ , whereas loose precipitate was formed within several days in the presence of the C-dots from glucosamine. The ratio between the C-dots and the gold precursor strongly affected the size of the produced Au NPs, as confirmed by the electronic absorption spectra (Fig. 1) and TEM images of the product. Slow sedimentation of the obtained Au NPs in the gravity field (in contrast to conventional Au NPs of the same size) evidenced their binding at the C-dot surface.



**Figure 1.** Electronic absorption spectra of the Au NPs synthesized at different concentrations of the glucose-based C-dots.

Hence, the reduction of  $\text{HAuCl}_4$  in the presence of C-dots is an interesting method to prepare Au NPs with potentially tunable size and shape. Importantly, in contrast to other analogous methods, the obtained nanoparticles can be easily isolated from the dispersion via centrifugation.

**Acknowledgements.** This work was supported by the Russian Foundation for Basic Research (project No 20-03-00692).



*Khapirova S. Yu.*<sup>1</sup>, *Aleshin G. Yu.*<sup>1</sup>, *Plakhova T. V.*<sup>1</sup>, *Shchukina A. A.*<sup>2</sup>, *Zubenko A. D.*<sup>2</sup>

<sup>1</sup>Moscow State University, Moscow, Russia

<sup>2</sup>A.N. Nesmeyanov Institute of Organoelement Compounds of Russian Academy of Sciences

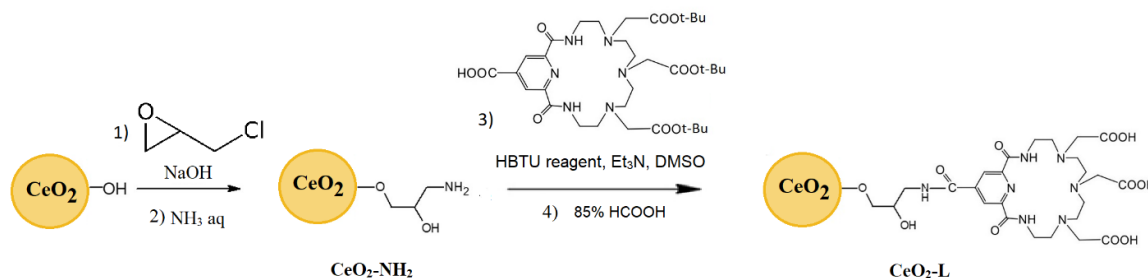
[khapirovasophia@gmail.com](mailto:khapirovasophia@gmail.com)

One of the main goals of research in the field of nuclear medicine is the development of radiopharmaceuticals that can deliver radionuclide to the target area or to the affected tissues of the body. This purpose can be achieved by conjugating a radionuclide to a vector that has an affinity for tumor cells.

Due to the high pH-sensitivity and small size, cerium (IV) oxide nanoparticles can exhibit vector properties and deliver the radionuclide closer to the tumor cell nucleus what can reduce harmful effect of ionizing radiation on healthy tissues. In addition, the redox-modulating and enzymatic activities of CeO<sub>2</sub> nanoparticles can be used for therapeutic purposes. One of the main characteristics of CeO<sub>2</sub> is its ability to inactivate free hydroxyl radicals and long-lived active forms of proteins, which are formed under the action of ionizing radiation of the radiopharmaceuticals.

Radionuclide can be bound to the surface of nanoparticles by direct or indirect methods. The radionuclide is included in the core or shell of the particle in the direct method, but this can lead to changes in the properties of nanoparticles. The indirect method consists in surface modification using bifunctional chelators that bind stably to the nanoparticle and then form a complex compound with the radionuclide.

In this work, conjugates of nanoparticles of cerium (IV) oxide (spherical nanoparticles with an average diameter of 3 nm) and bifunctional chelator L with six nitrogen atoms in a macrocycle were obtained by chemical surface modification (fig. 1). Modified cerium (IV) oxide nanoparticles were analyzed by IR and Raman spectrometry.



**Figure 1.** Scheme of surface modification of cerium (IV) oxide nanoparticles

The reactivity of cerium dioxide is determined by the redox potential of the Ce<sup>3+</sup>/Ce<sup>4+</sup> pair and the presence of oxygen vacancies on the particle surface. Thus, the research of the electronic features of cerium atoms in the studied samples was carried out using high-energy-resolution fluorescence-detected X-ray absorption spectroscopy (HERFD XANES) at L<sub>3</sub>-edge of Ce.

The efficiency of ligand binding to the surface of cerium (IV) oxide nanoparticles was analyzed by combined thermogravimetry with mass spectrometry (TG-MS). Weight loss occurred evenly in the range from 30 °C to 400 °C. Confirmation of the modification of the surface of nanoparticles at each stage were also studied by a series of ζ-potentials measurements at different pH values in the range from 2 to 11 (I = 0.01M) and determination of the isoelectric point by dynamic light scattering. It was shown that the modification of the particles surface with amino groups leads to a shift of the isoelectric point to the region of higher pH values, while the modification of nanoparticles by the ligand shifts it to the region of lower pH values.

In this way, the structures of the obtained substances were confirmed, the surface properties of the initial and functionalized nanoparticles were considered and the binding of the bifunctional chelator L with nanoparticles was proved as a result of the researches.

The research was funded by Russian Science Foundation, project number 21-73-00101.

# FLEXIBLE CARBON FIBER TEXTILES COATED WITH TRANSITION METAL OXIDES AS PERSPECTIVE ELECTRODE MATERIALS

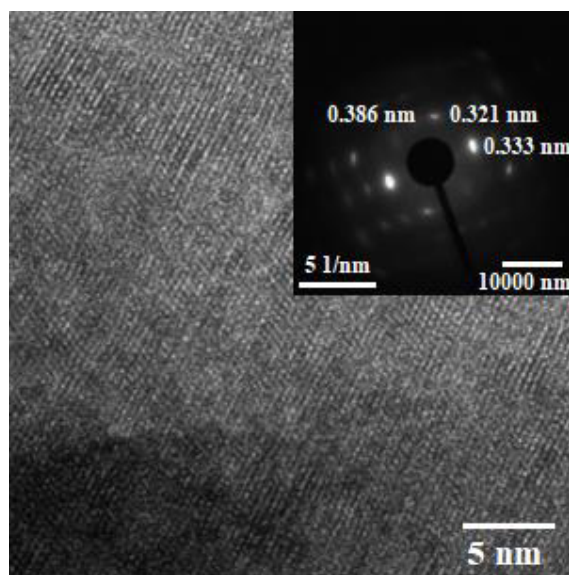
*Khramenkova A.V., Izvarin A.I., Ariskina D.N.*

Platov South-Russian State Polytechnic University (NPI), Novocherkassk, Russia  
Associate Professor  
[anna.vl7@yandex.ru](mailto:anna.vl7@yandex.ru)

One of the challenges of modern electrochemical power engineering is the creation of new efficient rechargeable energy storage devices. The use of supercapacitors - energy storage and conversion devices with a high power density and the ability to quickly recharge [1-2] is seen as promising for use as backup and auxiliary power sources in electronic devices.

This paper presents the results of obtaining flexible electrode materials based on oxides of manganese, iron, molybdenum, cobalt, vanadium on the surface of carbon fabric by the method of nonstationary electrolysis and the study of their physicochemical properties.

The studies of the obtained flexible electrode materials by the HRTEM method were carried out on the equipment of the RC "Nanotechnology" of St. Petersburg State University, by the XPS method - on the equipment of the Udmurt Federal Research Center of the Ural Branch of the Russian Academy of Sciences.



**Figure 1.** HRTEM image of flexible carbon fiber textiles coated with transition metal oxides. The inset showed SAED pattern

According to XPS, the basis of ultrathin (up to 3 nm) oxide layers on the surface of carbon fabric are molybdenum oxides with a significant content of vanadium oxides, with a small content of iron, manganese, and cobalt. Molybdenum is oxidized mainly to the 6+ state, iron - up to 2+ and 3+, manganese - not lower than 3+, vanadium - mainly up to 5+.

## References

- [1] Wang K., Huang Y., Wang M. et al. *Carbon*. **2017**, 125, 375–383
- [2] Cakici M., Reddy K. R., Alonso-Marroquin F. *Chemical Engineering Journal*. **2017**, 309, 151-158

Acknowledgements. This work has been carried out within framework of studies supported by Scholarship CP-3068.2021.1 granted by the RF President

# NOVEL METHOD OF GELATIN NANOPARTICLES SYNTHESIS

*Khramtsov P.V.<sup>1,2</sup>*

<sup>1</sup>Institute of Ecology and Genetics of Microorganisms UB RAS, Perm, Russia

<sup>2</sup>Perm State University, Perm, Russia

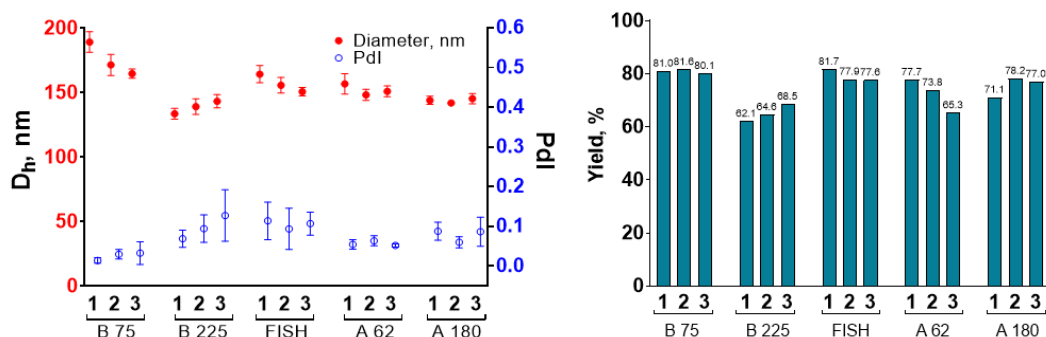
Researcher

khramtsov Pavel@yandex.ru

Gelatin is a product of partial hydrolysis of collagen. In the course of gelatin preparation, collagen is pre-treated under acidic or alkaline conditions, which results in obtaining two types of gelatin: type A and type B respectively. The main sources of gelatin are bovine skin, bovine hides, and cattle and pork bones, whereas fish and poultry gelatins are used to a limited extent.

Gelatin as well as many other proteins is used in the form of gelatin nanoparticles. Drug delivery is arguably the scientific field most intensively taking advantage of gelatin nanoparticles [1]. Indeed, many reports of gelatin based nanotherapeutics and nanovaccines were made in the past years. Potential applications of gelatin nanoparticles are not limited to therapeutics and vaccine development. Gelatin nanoparticles and microparticles together with molecular gelatin can serve as cheap collagen substitute, imitating extracellular matrix in cell culturing and tissue engineering. Gelatin nanoparticles improve mechanical properties (induction of thixotropy) of bioinks for 3D bioprinting and increased circulation tumor cell capture in microfluidic device. They also found applications in the preparation of Pickering emulsions for food chemistry.

We improved widely used desolvation method [2] of gelatin nanoparticles preparation. It was found that high-speed stirring promotes aggregation of gelatin nanoparticles in the course of synthesis. Moreover, slow dropwise addition of desolvating agent is not necessary. Quick addition of desolvating agent (preferably isopropyl alcohol) and subsequent short gentle mixing allows preparation gelatin nanoparticles from any gelatin source with both high and low bloom number. Gelatin nanoparticles from different gelatins (bovine gelatins, type B, 75 and 225 bloom, porcine gelatins, type A, 62 and 180 bloom, fish gelatin, 280 bloom) were synthesized by optimized scaled-up (hundreds of milligrams) method. Three batches of nanoparticles for each gelatin type were fabricated (Fig. 1).



**Figure 1.** Left - mean hydrodynamic diameters (mean $\pm$ SD) of gelatin nanoparticles (measured by DLS); right – yields of synthesis (percentage from initial gelatin weight).

## References

- [1] Hong S., Choi D.W., Kim H.N., Park C.G., Lee W., Park H.H. *Pharmaceutics*. **2020**, 12,604.
- [2] Coester C.J., Langer K., van Briesen H., Kreuter J. *J Microencapsul*. **2000**, 17,187.

**Acknowledgements.** This work was supported by Russian Foundation for Basic Research and the Government of Kaliningrad Region (projects No 19-415-393005 and No 19-015-00408).

# IMPACT OF ZINC OXIDE NANOPARTICLES STRUCTURAL PARAMETERS ON THEIR PHOTOCATALYTIC PROPERTIES UNDER UV AND VIS IRRADIATION

*Kochnev N.D.<sup>1</sup>, Kolokolov D.S., Bobrysheva N.P., Osmolowsky M.G., Voznesenskiy M.A., Osmolowskaya O.M.*

<sup>1</sup>Saint Petersburg State University, Saint Petersburg, Russia  
Student

[Nick\\_Kochnev@mail.ru](mailto:Nick_Kochnev@mail.ru)

Today, semiconductor materials are under active study and are a subject of great interest due to photocatalytic properties [1]. However, in recent years, many studies were devoted to their own photoluminescence. From a practical point of view, such materials can be promising both in ecology, for example, for wastewater treatment, and in medicine for visualization of individual biological components. It was noted that the photocatalytic and luminescent properties of these materials strongly depend on defects, namely, oxygen vacancies. Thus, by regulating the number of such defects, we can control physical and chemical properties of the obtained materials. Despite the large number of works and high relevance, this phenomenon is still poorly understood and requires additional study.

Zinc oxide is a wide-band semiconductor (3.3 eV), which has good photocatalytic properties [2], but also a strong intrinsic "green" photoluminescence [3], which is associated with the presence of oxygen vacancies in the resulting structures. In addition, it has a wide range of antibacterial properties, non-toxicity and biocompatibility. The presence of these properties makes it a very promising material for possible use in medicine as luminescent labels and, in addition, an effective photocatalyst for the treatment of domestic and industrial wastewater.

The purpose of this work is to study and to establish patterns of the influence of defects, namely, oxygen vacancies on the physicochemical properties of zinc oxide nanoparticles (NPs). For this purpose, two methods of preparation were chosen – chemical precipitation and hydrothermal synthesis. All obtained samples were characterized by X-ray diffraction (XRD), specific surface area estimation (SSA), scanning electron microscopy (SEM), Fourier-transform infrared spectroscopy (FTIR) and Raman spectroscopy. In addition, absorption spectra were recorded for further calculation of the band gap of the obtained samples.

The influence of various factors (concentration, temperature and pH) on the process of particle formation was investigated. It was determined that NaOH is the most suitable source of hydroxide ions, and the pH of the solution should be at least 12. Based on the XRD data, no additional phases were observed in the samples. Changes in the unit cell parameters for samples obtained by different methods indicate that each case has its own growth mechanism. The photocatalytic properties were also studied on the example of decomposition of the organic dye Methylene blue (MB) under two radiation sources in visible and UV regions. It was found that the obtained NPs exhibit the best photocatalytic properties in the UV region - after 10 minutes of irradiation, 80% of the organic dye decomposes, for comparison, in the visible region, only 30%. Thus, it has been shown that the obtained NPs can act as an effective photocatalyst in the UV region. In addition, within further work it is planned to study the photoluminescent properties of zinc oxide, to perform an investigation of the contribution of oxygen vacancies to the "green" photoluminescence of NPs and to compare the obtained results with calculated band structure.

## References

- [1] Karthikeyan C., Arunachalam P, et al. Recent advances in semiconductor metal oxides with enhanced methods for solar photocatalytic applications // *Journal of Alloys and Compound*. 2020. V. 828.
- [2] Das A., Nikhil S. K., Nair R. G. Influence of surface morphology on photocatalytic performance of zinc oxide: a review // *Nano-Structures & Nano-Objects*. 2019. V. 19.
- [3] Pramanik S. Mondal S., et. al. Role of oxygen vacancies on the green photoluminescence of microwave-assisted grown ZnO nanorods // *Journal of Alloys and Compounds*. 2020. V. 846.

Acknowledgements. Scientific research was performed using the equipment of the Research Park of St. Petersburg State University (Centre for X-ray Diffraction Studies, Chemical Analysis and Materials Research Centre, Centre for Innovative Technologies of Composite Nanomaterials, Centre for Optical and Laser Materials Research, Centre for Magnetic Resonance).

Nanothermometry is a promising and rapidly developing area in contemporary science [1]. The contactless temperature reading with the good spatial and temporal resolution achieved by monitoring the steady-state and kinetics photoluminescence properties of materials has received immense attention owing to their potential applications in biology, medicine, physical and chemical sciences. Among phosphors of different nature possessing temperature-dependent luminescence properties, crystalline oxides doped with rare earth ions are of special interest. These oxides can be utilized as low cost, photo- and temperature stable, chemically inert, and biocompatible nanothermometers with high immunity to blinking and photobleaching.

Ratiometric technique is the most commonly used for luminescence thermal sensing because of the independence of temperature measurement on external factors such as excitation power, phosphor quantity or spatial distribution of the sample. Ratiometric thermometry is usually based on the analysis of the luminescence intensities ratio (LIR) between thermally coupled levels (TCLs). The sensitivity of this technique is determined by the energy difference between the TCLs ( $\Delta E$ ), which defines the relative occupancy of the energy levels. When the energy gap is small ( $\sim 200$  cm<sup>-1</sup>), the system can provide temperature measurements in a wide range of temperatures but with low relative sensitivity. Increase of the gap leads to the relative thermal sensitivity enhancement, but when the  $\Delta E$  exceeds 2000 cm<sup>-1</sup>, the coupling between the levels decreases, and the population of the upper level in the desired temperature range becomes too small to provide accurate sensing. To overcome the intrinsic limitation of relative thermal sensitivity, LIR should be calculated using luminescence bands from two different active centers.

This work is focused on study of co-doped and mixed YVO<sub>4</sub>:Eu<sup>3+</sup>/Nd<sup>3+</sup> dispersed systems as well as their possible application for contactless thermometry. Co-doped and single nanophosphors were synthesized using a modified Pechini technique, which allows obtaining low agglomerated nanoparticles due to additional heat treatment in a molten salt [2]. Contactless thermometry was successfully performed via monitoring LIR between <sup>5</sup>D<sub>0</sub>-<sup>7</sup>F<sub>4</sub> (Eu<sup>3+</sup> ion) and <sup>4</sup>F<sub>5/2</sub>-<sup>4</sup>I<sub>9/2</sub> (Nd<sup>3+</sup> ion) transitions in 299–466 K temperature range (Fig. 1). The thermometric performances were studied and compared with earlier reported thermal sensors in terms of thermal sensitivity, temperature resolution, and repeatability.

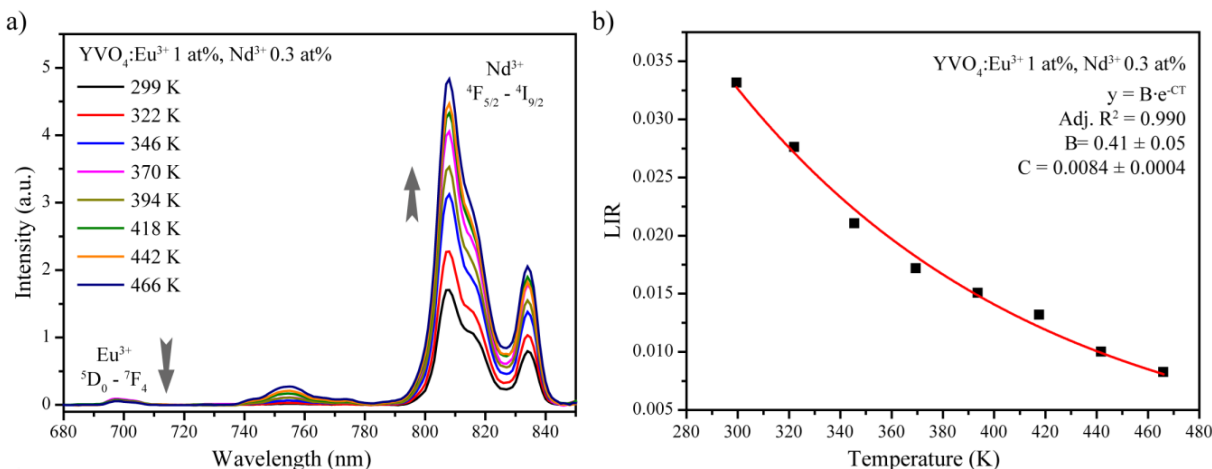


Figure 1. Emission spectra of a) co-doped YVO<sub>4</sub>:Eu<sup>3+</sup> 1 at.%, Nd<sup>3+</sup> 0.3 at.% nanoparticles measured at various temperatures; b) LIR evolution of co-doped YVO<sub>4</sub>:Eu<sup>3+</sup> 1 at.%, Nd<sup>3+</sup> 0.3 at.% nanoparticles.

### References

- [1] del Rosal B. et al *Adv. Funct. Mater.* **2018**, 28 1806088  
 [2] Kolesnikov I.E. et al *Nanoscale* **2020**, 12, 5953-5960

**Acknowledgements.** This research has been supported by the Russian Science Foundation (№ 21-79-10018). Experimental studies were carried out in “Center for Optical and Laser materials research”, “Research Centre for X-ray Diffraction Studies”, “Interdisciplinary Resource Center for Nanotechnology” (St. Petersburg State University).

## A NEW HAFNIUM-BASED RADIOSENSITIZER PROVIDE SELECTIVE X-RAY INDUCED CYTOTOXICITY *IN VITRO*

*Kolmanovich D.D.*<sup>1</sup>, *Popov A.L.*<sup>1</sup>, *Popova N.R.*<sup>1</sup>, *Shcherbakov A. B.*<sup>2</sup>, *Ivanov V. K.*<sup>3, 4</sup>

<sup>1</sup> Institute of Theoretical and Experimental Biophysics, Russian Academy of Sciences,  
Pushchino, Moscow region, Russia

<sup>2</sup> Zabolotny Institute of Microbiology and Virology, National Academy of Sciences of Ukraine,  
Kyiv D0368, Ukraine

<sup>3</sup> Kurnakov Institute of General and Inorganic Chemistry, Russian Academy of Sciences,  
Moscow 119991, Russia

<sup>4</sup> National Research Tomsk State University, Tomsk 634050, Russia

Student

kdd100996@mail.ru

Radiation therapy still remains the «gold standard» in cancer treatment. Lung and breast cancer are the most common types of cancer cases. One of the most promising approaches to increasing the efficiency of tumor radiation therapy is the use of radiosensitizers. This approach allows achieving a therapeutic effect at lower radiation doses, thereby reducing radiation exposure to healthy tissues.

One of the promising candidates as a nanodispersed radiosensitizer is nanocrystalline hafnium oxide. Hafnium is a heavy Z-element which it is able to efficiently absorb and re-emit ionizing radiation energy. Here we reported about new scheme of hafnium-containing nanocomposite synthesis with their additional functionalization using flavin mononucleotide [1]. This technique makes it possible to obtain a stable sol of a hafnium-containing nanocomposite with ultra-small particles (hydrodynamic radius of 3-4 nm) and high colloidal stability. The radiosensitization effects of hafnium-containing nanocomposite were investigated on normal and cancer cell lines using MTT assay under X-ray exposure (15 Gy). The intracellular localization analysis of nanocomposite showed that in A431 and MCF-7 cells effectively uptake the nanocomposite within an hour, while mouse fibroblasts and mesenchymal stem cells lower efficiency of nanocomposite endocytosis in high concentration (0.2 mg/ml). Moreover, after 12 hours of incubation, the maximum of nanocomposite cellular accumulation was observed predominantly in lysosomes.

The results of radiosensitization of hafnium-oxide nanocomposite via MTT assay demonstrated a strong dose-dependent decrease in the viability of tumor cell lines (A431 and MCF-7) after irradiation at a dose of 15 Gy with the nanocomposite at 0.3 mg/ml. At the same time, these cytotoxicity effects of hafnium-containing nanocomposite were significantly lower in relation to normal cells (L929 and DPSc).

Thus, according to our results, a hafnium-containing nanocomposite functionalized with a flavin mononucleotide can be considered as a promising radiosensitizer agent for X-ray radiation therapy.

### References

[1] Bartmann L., Schumacher D., Saskia von Stillfried et al. *Front. Pharmacol.*, **2019**, 1467-1483

Acknowledgements. This work was supported by Russian Foundation for Basic Research (project No 20-33-70236).

## CORRELATION BETWEEN MORPHOLOGICAL PARAMETERS AND FUNCTIONAL PROPERTIES OF EUROPIUM-DOPED BOEHMITE NANOPARTICLES

*Kolokolov D.S., Marakaryan A.A., Kolesnikov I.E., Osmolowsky M.G.,  
Bobrysheva N.P., Voznesenskiy M.A., Osmolovskaya O.M.*

<sup>1</sup>Saint Petersburg State University, Saint Petersburg, Russia  
PhD student  
[kolokolov.d@gmail.com](mailto:kolokolov.d@gmail.com)

Photoluminescence is a nonthermal light emission of a substance. This effect attracts great interest due to wide range of its applications: selective qualitative and quantitative analysis, creation of light sources, lasers, application for the analysis of biological objects in medicine. The most interesting from the practical point of view is the case of photoluminescence with light emission excitation under light irradiation.

Substances capable of luminescence, are divided into organic and inorganic. In organic compounds, luminescence occurs due to the presence of various functional groups, while in inorganic ones – due to the features of the crystal structure or the presence of lanthanide or actinide atoms in the matrix.

Currently, researchers are paying more and more attention to luminescent materials based on doped inorganic nanoparticles. Such interest is associated with their low toxicity and high hydrophilicity, which makes it possible to use such particles as luminescent labels in medicine.

Controlling size, quantum yield, quenching concentration, and luminescence excitation wavelength of luminescent nanoparticles is currently actual and actively studied problem.

High popularity of europium as a dopant is due to its independent of crystallographic environment luminescence wavelength. At the same time, boehmite nanoparticles ( $\gamma$ -AlOOH) attract great interest due to the set of useful properties, such as biocompatibility, non-toxicity, high sorption characteristics, as well as high crystallinity and the possibility of developing a scalable method of hydrothermal synthesis.

Europium-doped boehmite nanorods and nanoplates were obtained by the hydrothermal method by varying the pH of the reaction medium. It is shown that the doping limit for nanoplates is in the range of 5-10 mol.% of europium, while for nanorods it is much lower. All of the samples were characterized by XRD, FTIR, SSA, TEM, XPS, TGA-DSC. The photoluminescence was measured according to a standard procedure using nanoparticles pressed into tablets. In addition, PL was also measured in suspensions of nanoparticles in order to investigate the practical application as PL labels. Comparison of these two methods was carried out for the first time.

The obtained nanoparticles are monocrystalline. For nanorods length is varying from 91 to 125 nm and width from 25 to 29 nm. For nanoplates length is varying from 53 to 67 nm and width from 15 to 24 nm. The particle size increases with an increase in the europium concentration, while these values are lower than for the reference nondoped sample. The XPS data was used to estimate the amount of oxygen vacancies in the synthesized samples.

A study of the thermal properties of the obtained samples showed that for doped samples the transition temperature to aluminum oxide does not depend on the concentration of the dopant, the shape and size of the particles.

It is shown that in the case of pressed doped samples, the emission at 620 and 700 nm is associated with the luminescence of europium. For nanorods the concentration quenching is in the range of 1-5 mol.% of the dopant. It is not the case for the nanoplates, which emission is associated with the different position of the dopant in the crystal structure of the matrix. There is a low-intensity luminescence peaks in the same range for undoped samples which is associated with the presence of oxygen vacancies in them.

For suspensions of nanoparticles of undoped and doped samples the luminescence intensity at 620 nm is associated with oxygen vacancies in the structure and decreases with a decrease in the number of oxygen vacancies in doped samples. The luminescence intensity at 700 nm is a superposition of contributions from oxygen vacancies and europium and demonstrates a quenching tendency similar to pressed samples.

The research was carried out on the basis of the resource centers "Centre for X-ray Diffraction Studies", "Chemical Analysis and Materials Research Centre", "Centre for Optical and Laser Materials Research", "Centre for Innovative Technologies of Composite Nanomaterials", "Centre for Physical Methods of Surface Investigation" of the Science Park of St. Petersburg State University.

# HYDROGENATION OF EUTECTIC MIXTURE OF BIPHENYL AND DIPHENYLMETHANE OVER SUPPORTED PLATINUM CATALYSTS

*Kondrateva V.U.<sup>1</sup>, Martynenko E.A.<sup>1</sup>, Verevkin S.P.<sup>1,2</sup>*

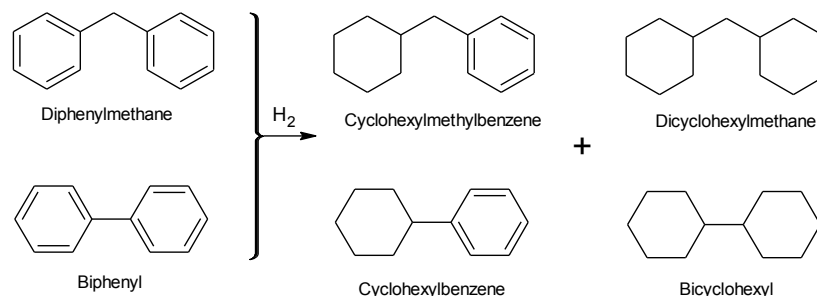
<sup>1</sup>Samara State Technical University, Samara, Russia

<sup>2</sup>University of Rostock, Rostock, Germany

Student

[kondratiieva97@yandex.ru](mailto:kondratiieva97@yandex.ru)

In this work, we studied a eutectic mixture as a liquid organic hydrogen carrier (LOHC), consisting of biphenyl (C<sub>12</sub>H<sub>10</sub>, solid) and diphenylmethane (C<sub>13</sub>H<sub>12</sub>, liquid) with a mass distribution (wt%) of 35:65. The eutectic mixture has been proven to be liquid at ambient temperature, which meets the requirements for an efficient hydrogen storage system.



**Figure 1.** Hydrogenation scheme of the eutectic mixture of the biphenyl and diphenylmethane

Pt/Sup catalysts were prepared, where MCM-48,  $\gamma$ -Al<sub>2</sub>O<sub>3</sub>, SiO<sub>2</sub> were used as supports (Sup). The synthesized catalysts were investigated by the methods of low-temperature nitrogen adsorption, temperature-programmed reduction (TPR), and high-resolution transmission electron microscopy. The catalytic properties of the prepared catalysts were tested in liquid-phase hydrogenation of the eutectic mixture of biphenyl and diphenylmethane under the following conditions: temperature range 150-170°C, pressure 1-4 MPa, liquid hourly space velocity (LHSV) of 5-15 h<sup>-1</sup> and hydrogen to feedstock ratio 500 nl/l. A model mixture of 2 wt.% solutions of the eutectic mixture in heptane was used as a raw material.

**Table 1.** Textural and structural characteristics of prepared catalysts

Sample	S <sub>BET</sub> , m <sup>2</sup> /g	V <sub>pore</sub> , sm <sup>3</sup> /g	D <sub>pore</sub> , nm	Particles size Pt, nm	Conversion, %mass	
					biphenyl	diphenylmethane
2 Pt/MCM-48	1348	0,56	3,8	2.0	86,0	98,0
2 Pt/SiO <sub>2</sub>	320	0,93	8,4	3.1	83,0	80,0
2 Pt/Al <sub>2</sub> O <sub>3</sub>	229	0,81	11,2	5.6	61,6	44,0

Catalyst 2Pt/MCM-48 exhibits significantly higher activity in hydrogenation/dehydrogenation reactions due to an increase in the dispersion and, accordingly, the availability of the formed active centers. According to the data obtained, the activity of the catalysts decreases in the following order: 2Pt/MCM-48 > 2Pt/SiO<sub>2</sub> > 2Pt/Al<sub>2</sub>O<sub>3</sub>. The conversion of biphenyl and diphenylmethane was close to maximum (80-90 %mass), confirming the high hydrogen storage capacity.

Based on the results obtained, it can be concluded that a eutectic mixture consisting of biphenyl and diphenylmethane, in conjunction with an effective catalyst, can be applied to hydrogen storage systems for stationary applications.

Acknowledgments. This work was supported by the Russian Science Foundation, grant 14Z50.31.0038.



*Koptyaev A.I.<sup>1</sup>, Sachkov Yu.I.<sup>1,2</sup>, Travkin V.V.<sup>1,2</sup>, Stuzhin P.A.<sup>1</sup>*

<sup>1</sup> Ivanovo State University of Chemistry and Technology, Ivanovo, Russia

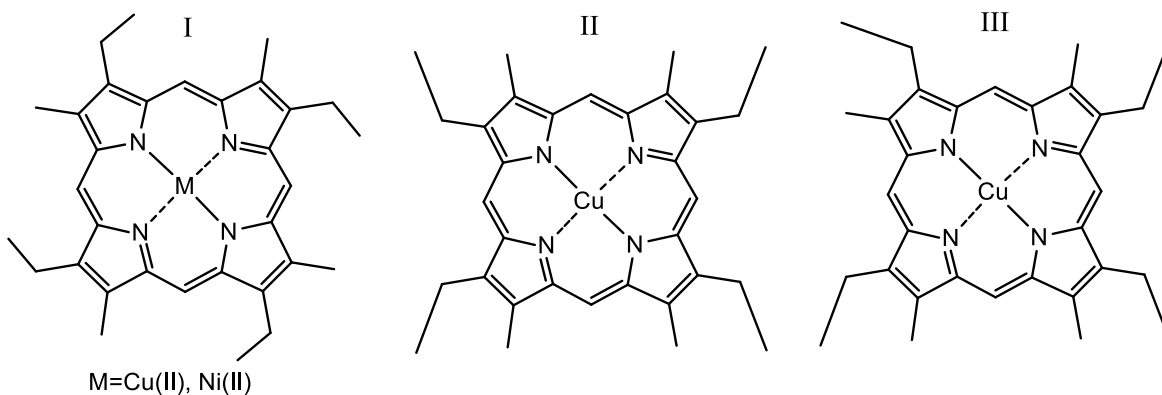
<sup>2</sup> Institute for Physics of Microstructures RAS, Nizhny Novgorod, Russia

Researcher

[akisuct@gmail.com](mailto:akisuct@gmail.com)

Tetrapyrrolic metallocomplexes are the only semiconductors occurring in the nature, which guarantees their unlimited source and arouses great interest among researchers working in the field of green energy. Etioporphyrins were found in crude oil and isolated as metal complexes more than 40 years ago. More recently, etioporphyrin-I (NiEtiop-I) has shown one of the highest mobilities of the majority charge carriers (holes) in thin-film field effect transistors among other porphyrin-type compounds [1], which opens up bright prospects for application in optoelectronic devices. However, the use of NiEtiop-I as a donor component in a planar heterojunction with fullerene did not lead to fabrication of an efficient photovoltaic cell. Hence, to gain a deeper understanding of the charge transport mechanisms in etioporphyrin layers, it is first necessary to elucidate their supramolecular organization.

Here, we report on the nanoscale morphology and (photo)conductive properties of molecular films formed by NiEtiop-I and three position isomers of copper(II) etioporphyrin: CuEtiop-I, II and III – see, Fig. 1. Films several tens nanometers thick were obtained by thermal deposition in a high vacuum and characterized by the X-ray diffraction, optical spectroscopy and microscopic techniques. The dark conductivity and its activation by sunlight have been studied in various environments with particular interest in the suitability of these compounds for use in hybrid photovoltaic devices.



**Figure 1.** Molecular structure of etioporphyrins used in work.

It was found that Etiop molecules in thus deposited layer are highly ordered, while r.m.s. roughness of surface typically does not exceed 1 nm. The samples are more resistant to heat treatment in air than the solution-processed films of their nearest analogues chlorins. The photovoltage in the simple sandwich-type cells with a transparent anode and a low-workfunction metal cathode amounts to 0.8 V.

#### References

[1] Xu Z.-X., Xiang H.-F., Roy V.A.L., Chui S.S.-Y., Che C.-M., Lai P.T. *Appl. Phys. Lett.* **2008**, 93, 223305

Acknowledgements. This work was supported by the Russian Science Foundation (project No 20-13-00285).

## DEVELOPMENT OF AN ADVANCED PLATFORM FOR CANCER THERANOSTICS BASED ON TANTALUM OXIDE NANOPARTICLES

*Koshevaya E.D.*<sup>1,2</sup>, *Morozov V.N.*<sup>3</sup>, *Kolyvanova M.A.*<sup>2,3</sup>, *Krivoshapkina E.F.*<sup>3</sup>, *Krivoshapkin P.V.*<sup>3</sup>

<sup>1</sup>Institute of Chemistry, Komi Science Centre of the Ural Branch of the Russian Academy of Sciences, Syktyvkar, Russia

<sup>2</sup>State Research Center-Burnasyan Federal Medical Biophysical Center of Federal Medical Biological Agency, Moscow, Russia

<sup>3</sup>Emanuel Institute of Biochemical Physics, Russian Academy of Sciences, Moscow, Russia

<sup>4</sup>SCAMT Laboratory, ITMO University, Saint-Petersburg, Russia  
katiakosh@gmail.com

The present work is aimed to investigate the potential of Ta<sub>2</sub>O<sub>5</sub>-based nanoparticles (NPs) for multimodal theranostic applications. Theranostics is a novel approach to create pharmaceuticals which combine both therapeutic and diagnostic capabilities. Tantalum oxide NPs are a perspective platform for developing multimodal theranostic agent because they inherently possess biocompatibility, radiosensitising properties (therapeutic capability) and X-ray contrast performance (diagnostic capability). Moreover, Ta<sub>2</sub>O<sub>5</sub> is an excellent host matrix for rare-earth element dopants giving rise to adjustable luminescent properties, including upconversion ones. This enables to design a converter for the radical destruction of malignant cells for enhanced radiotherapy, which at the same time offer dual imaging capabilities (luminescence and X-ray diagnostics). An additional point is high chemical inertness that makes Ta<sub>2</sub>O<sub>5</sub> NPs safe for human organism while being non-irradiated.

In this regard, the developing of the synthesis procedure of undoped and lanthanide (Eu, Er, Yb)-doped Ta<sub>2</sub>O<sub>5</sub> NPs was performed. The phase composition, morphology, surface properties and thermal behavior of obtained materials were studied by XRD, EDX, TEM, FTIR, TG/DSC, and nitrogen gas adsorption-desorption. A multilateral study on the influence of different parameters (pH, electrolyte concentration) on hydrosol stability of Ta<sub>2</sub>O<sub>5</sub> NPs were studied in a wide range of pH (2–9) and background electrolyte concentrations (0.001–0.15 M NaCl) by dynamic light scattering, laser Doppler electrophoresis, potentiometric titration, and photometry. The isoelectric point and point of zero charge of Ta<sub>2</sub>O<sub>5</sub> NPs, as well as the critical coagulation concentration were determined. The influence of the time of ultrasonic treatment on the stability of aqueous dispersions was investigated. Based on the obtained results, the preparation protocol of highly stable hydrosols with concentrations 0.2–20 mg/mL and mean hydrodynamic diameter of aggregates <100 nm was developed. *In vitro* Cytotoxicity (MTT-test) and *In vivo* Acute Toxicity studies were performed for the obtained materials. The radiosensitizing effect of Ta<sub>2</sub>O<sub>5</sub> NPs was showed on a plasmid DNA model, as well as on human fibroblast cells. The obtained sols provide high CT contrast (450 HU for a 20 mg NPs/mL) both in theoretical calculations and *in vivo* (rat gastrointestinal tract) [1]. Photoluminescence measurements were performed on thermally annealed doped NPs with the use of mercury lamp and NIR laser as sources of excitation [2].

### References

- [1] Koshevaya E. D., Nazarovskaia D., Simakov M., Belousov A. V., Morozov V. N., Gandalipov E., Krivoshapkina E. F., Krivoshapkin P. V. *J. Mater. Chem. B* **2020**, *8*, 8337-8345  
[2] Kiselev G.O., Kiseleva A.P., Ilatovskii D.A., Koshevaya E.D., Nazarovskaia D.A., Gets D.S., Vinogradov V.V., Krivoshapkin P.V., Krivoshapkina E.F. *Chem. Commun.* **2019**, *55*, 8174-8177

Acknowledgements. This work was supported by Russian Foundation for Basic Research (project No 18-29-11078).

EFFECT OF THE SILICA PRECURSOR CONCENTRATION ON THE CONTINUITY  
OF THE CORE-SHELL COATING OF Fe<sub>3</sub>O<sub>4</sub>/SiO<sub>2</sub> NANOPARTICLES  
AND THE MAGNETIC CHARACTERISTICS OF THE COMPOSITE  
*Kudymov V. K., Kozlova L. A., Ponomareva A. N., Zemtsova E. G.*

*Saint Petersburg State University, Institute of Chemistry, Department of Solid State Chemistry*  
[st075880@student.spbu.ru](mailto:st075880@student.spbu.ru)

In recent years, significant attention has been focused on deeper understanding of the magnetic nanoparticles nature, their behavior, and the search for new areas of their applicability. For pharmaceutical and biomedical purposes, magnetic nanoparticles must have a size that lies in the nanometer range, which provides superparamagnetic properties along with high magnetization, as well as a narrow size distribution. The layer covering the magnetic nanoparticles surface should provide aggregate stability and biocompatibility. As a rule, to produce magnetic nanoobjects, synthesis in nanoreactors or synthesis of "core-shell" particles is used [1]. However, when creating magnetic materials, two main problems arise: the development of the synthesis of nanoparticles of reproducible shape and size, as well as the effective nanoparticles stabilization with the preservation of the characteristic nanoscale state properties.

The aim of this work is to study the effect of the silica precursor concentration on the continuity of the core-shell Fe<sub>3</sub>O<sub>4</sub>/SiO<sub>2</sub> coating and the magnetic characteristics of the composite.

Fe<sub>3</sub>O<sub>4</sub> nanoparticles were obtained by co-precipitation of iron (II) and (III) chlorides solutions with ammonia. Fe<sub>3</sub>O<sub>4</sub>/SiO<sub>2</sub> nanoparticles were synthesized by the Stober method. Totally 3 samples were synthesized with different mass ratio magnetite-tetraethoxysilane (a precursor of silica): 2:1 (sample 1), 1:1 (sample 2), and 1:2 (sample 3). The effect of the silica precursor concentration in the reaction mixture on the continuity of the silica shell was studied (Table 1).

*Table 1. Physical and chemical parameters of synthesized samples*

Sample	d <sub>Av</sub> (SEM), nm	d <sub>Av</sub> (DLS), nm	pH <sub>IEP</sub>	M <sub>max</sub> , Am <sup>2</sup> /kg
Fe <sub>3</sub> O <sub>4</sub>	6	4.70 ± 0.09	7.90 ± 0.16	75.0 ± 1.5
Fe <sub>3</sub> O <sub>4</sub> @SiO <sub>2</sub> No.1	9	7.50 ± 0.15	3.40 ± 0.07	60.0 ± 1.2
Fe <sub>3</sub> O <sub>4</sub> @SiO <sub>2</sub> No.2	14	15.6 ± 0.3	2.90 ± 0.06	48.0 ± 1.0
Fe <sub>3</sub> O <sub>4</sub> @SiO <sub>2</sub> Np.3	30	28.7 ± 0.6	2.10 ± 0.04	38.0 ± 0.8
SiO <sub>2</sub>	-	-	1.80 ± 0.04	-

d<sub>Av</sub> (SEM), nm – average particle size according to SEM; d<sub>Av</sub> (DLS), nm – average particle size according to dynamic light scattering; pH<sub>IEP</sub> – experimental pH of the isoelectric point; M<sub>max</sub>, Am<sup>2</sup>/kg – maximum magnetization of samples

With an increase in the silica precursor to magnetite mass ratio, we can confirm the complete core particles coating with a shell. Also, with an increase in the silica precursor concentration in the reaction mixture, there is a decrease in the maximum magnetization, due to an increase in the amount of the silica phase in the material, and the shape of the magnetization curves indicates the superparamagnetic state of the obtained materials.

#### References

[1] Reddy, L.H., Arias, J.L., and Couvreur, J.N., *Chem. Rev.*, **2012**, vol. 112, p. 5818. doi 10.1021/cr300068p

Acknowledgements. The authors express their gratitude to the resource center of the St. Petersburg State University Science Park "Nanotechnologies", "Optical and laser methods of substance research", "Innovative technologies of composite nanomaterials".

# NANOIMPACT EXPERIMENTS OF LITHIUM-ION INTERCALATING NANOPARTICLES FOR REDOX FLOW BATTERIES WITH SOLID BOOSTERS

*Kurbatova A.A.*<sup>1</sup>, *Gvozdik N.A.*<sup>1</sup>, *Nikitina V.A.*<sup>1</sup>

<sup>1</sup> Skolkovo Institute of Science and Technology, Moscow, Russia  
Student

[Anna.Kurbatova@skoltech.ru](mailto:Anna.Kurbatova@skoltech.ru)

Redox flow battery (RFBs) is a particularly promising technology for large-scale installations due to their unique ability of independent power and capacity scaling and long lifetime. RFB can be used over 20000 cycles, while lithium-ion batteries are limited by 6000. However, the energy density of RFBs remains a critical problem and requires large amounts of electrolyte to achieve modest energy storage capacities. This limitation makes non-scalable implementation of many organic redox molecules as the maximum energy density of classical RFB is limited by the solubility of the active species. To bypass these limitations, in 2013 an innovative approach was proposed by Wang and co-workers [1]. Solid materials, which are indirectly charged/discharged via a soluble redox mediator, were used as the extra energy storage media. Solid materials or solid-boosters, in other words, potentially enhance the volumetric capacity decreasing the total required volume of expensive soluble organic compounds [2].

The spontaneous reactions between the solid-booster and the organic mediator have not been investigated in detail yet. The electrochemical responses from independent particles without constant contact with the solid electrode surface are little known. In this paper, we present the first results of such process investigation by uniting the concentration detection of organic molecules in time and getting the information from the particles during the collision with the electrode, called nano-impact experiments. Cation-intercalating materials can be used as solid-boosters in nano-impact measurements.  $\text{LiMn}_2\text{O}_4$  nanoparticles were used in this research. Single collision of the particles helps to investigate the diffusion process of ions inside the particle and the accompanying with electrons transfer. Lithium-ion transfer through the solid-liquid interface between  $\text{LiMn}_2\text{O}_4$  particle and aqueous electrolyte was detected as the rate-determining step in suspensions [3]. The kinetics of the interfacial ion transfer defines a theoretical upper limit for the reaction rates using  $\text{LiMn}_2\text{O}_4$  as a solid-booster in an aqueous environment. We proposed that this limitation comes from an insufficient electron conductivity.

We synthesized nanoparticles of  $\text{LiMn}_2\text{O}_4$  and  $\text{LiMn}_2\text{O}_4$  covered with carbon coating to get two materials with different conductivity. The electrochemical performance of obtained materials was characterized by cyclic voltammetry from composite electrodes. Finally, the statistical analysis of nano-impact experiments with  $\text{LiMn}_2\text{O}_4$  suspensions on carbon fiber microelectrodes was performed at different overpotentials to deduce the influence of carbon coating. As a result, enhanced electron conductivity led to a decrease of the overpotential at which the nano-impacts occur; hence, a partial shift of limiting step to the diffusion control was observed. Thus, the electron conductivity of solid-booster is an essential property that influences the reaction rate.

## References

- [1] Huang, Q., Li, H., Grätzel, M., & Wang, Q. *Phys. Chem. Chem. Phys.* **2013**, 15(6), 1793–1797
- [2] Zanzola, E., Dennison, C. R., Battistel, A., Peljo, P., Vrabel, H., Amstutz, V., & Girault, H. H. *Electrochimica Acta.* **2017**, 235, 664–671.
- [3] Zampardi, G., Batchelor-McAuley, C., Kätelhön, E., & Compton, R. G. *Angewandte Chemie.* **2016**, 129(2), 656–659.

## SYNTHESIS AND CATALYTIC PROPERTIES OF SPINEL FERRITES

*Kurkin N.A.<sup>1</sup>, Tomina E.V.<sup>1,2</sup>, Pavlenko A.A.<sup>1</sup>, Cherednichenko I.S.<sup>1</sup>,  
Konkina D.A.<sup>1</sup>, Volkov A.S.<sup>1</sup>, Doroshenko A.V.<sup>1</sup>*

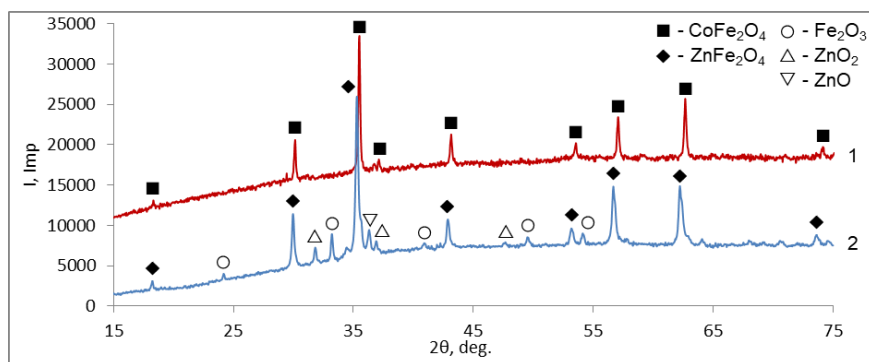
<sup>1</sup>Voronezh State University, Voronezh, Russia

<sup>2</sup>Voronezh State University of Forestry and Technologies Named after G.F. Morozov, Voronezh, Russia  
Student

kurkin.nik@yandex.ru

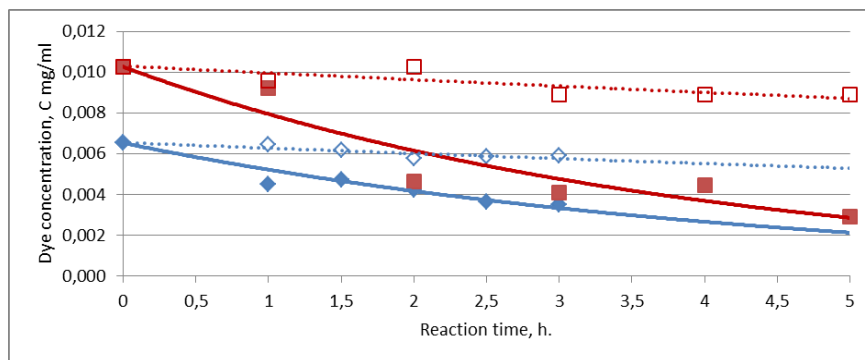
Fenton-like processes have recently attracted interest [1]. In this work, we investigated the catalytic activity of cobalt and zinc ferrite nanopowders with respect to hydrogen peroxide in the decomposition reaction of the methylene orange dye.

Cobalt and zinc ferrite nanopowder was synthesized by the citrate method [2]. XRD data are shown in Figure 1. The particle sizes, calculated using the Debye-Scherrer formula, were 44 nm for cobalt ferrite and 37 nm for zinc ferrite. A sample of zinc ferrite contains 26.7% wt. of impurities, while sample of cobalt ferrite is single phase.



**Figure 1.** Diffraction patterns of samples (1 - cobalt ferrite sample, 2 - zinc ferrite sample).

To study the catalytic properties of samples a reaction solution, containing: dye and 10 wt.% of hydrogen peroxide, was prepared. The pH of the solution was maintained at 4.5. The kinetic curves are shown in Figure 2.



**Figure 2.** Kinetics (A red line represents cobalt ferrite as a catalyst, blue line represents zinc ferrite as a catalyst. A dotted line represents control samples without a catalyst.)

Thus, it has been demonstrated that nanosized cobalt and zinc ferrites are effective catalysts for the decomposition of hydrogen peroxide with the formation of radicals acting as active oxidizing agents for organic dyes, including methylene orange. This opens up prospects for the use of nanosized ferrites as catalysts for Fenton-like oxidation of various toxic and polluting substances in wastewater, such as formaldehyde, phenol, etc.

### References

- [1] Tatarchuk T., et. al. *Ceramics International*. **2020**, 46, 27517-27530
- [2] Ali T.M., Ismail S.M., Mansour S.F. *J Mater Sci: Mater Electron*. **2021**, 32, 3092-3103

Acknowledgements. The research results were partially obtained on the equipment of The collective use Center of Voronezh state University. URL: <http://ckp.vsu.ru>

SYNTHESIS AND PHOTOCATALYTIC ACTIVITY OF ORGANICALLY MODIFIED  
LAYERED PEROVSKITE-LIKE TITANATES  $HLnTiO_4$  ( $Ln = La, Nd$ )

Kurnosenko S.A.<sup>1</sup>, Voitovich V.V.<sup>1</sup>, Silyukov O.I.<sup>1</sup>, Rodionov I.A.<sup>1</sup>, Zvereva I.A.<sup>1</sup>

<sup>1</sup>Saint Petersburg State University, Saint Petersburg, Russia  
PhD student  
serega.wot@mail.ru

Overcoming many global environmental problems, caused by rapid industrial growth and the active use of traditional fuels in the XX–XXI centuries, is associated with the development of waste-free technologies and alternative energy sources including hydrogen fuel. With this regard, photocatalytic decomposition of water and water-organic media is considered as an effective and environmentally friendly approach to the hydrogen production.

One of the classes of heterogeneous photocatalysts being actively explored is represented by layered perovskite-like oxides – solid crystalline substances whose unique structure can be described as the regular alternation of negatively charged intergrowth slabs with a thickness of  $n$  corner-shared perovskite octahedra and interlayer spaces containing cations or complex cationic units [1]. The propensity of many layered perovskites for low-temperature chemical transformations involving their interlayer space makes these materials promising photocatalysts allowing one to fine-tune the required properties and having a great potential for further modification. In particular, the improvement of their photocatalytic activity is known to be carried out via cationic and anionic substitution, the creation of composites with metal co-catalysts, sensitization with dyes as well as exfoliation into perovskite nanosheets [2].

The present research focuses on a fundamentally new approach to increasing photocatalytic activity of layered perovskite-like oxides – modification of their interlayer space with organic components. In particular, we have synthesized for the first time two series  $n$ -alkylamine and  $n$ -alkoxy derivatives of titanates  $HLnTiO_4$  ( $n = 1$ ) and investigated the kinetics of light-driven hydrogen generation from the model aqueous solution of methanol over the hybrid samples obtained. Photocatalytic measurements were carried out in accordance with a complex scheme taking into account changes in the photocatalyst concentration because of sedimentation, pH shifts and possible lamination of the samples into nanosheets. Special attention was also paid to the feasible improvement of the photocatalytic activity of the samples via their surface modification with Pt nanoparticles as a cocatalyst. All the inorganic-organic photocatalysts obtained were preliminarily characterized by a set of modern physical-chemical methods including X-ray diffraction, Raman, nuclear magnetic resonance and diffuse reflectance spectroscopy, thermogravimetry, CHN-analysis, and scanning electron microscopy.

It has been established that the organic modification of the interlayer space of the titanates is an efficient way to improve their photocatalytic activity. The rate of increase in the activity turns out to be up to 70 times compared to that of the initial unmodified titanates and up to 17 times in comparison with the «classic» photocatalyst  $TiO_2$  P25 Degussa. Photocatalytic activity of the titanates and their derivatives correlates with the hydration degree of their interlayer space, which is considered a separate reaction zone in photocatalysis. Insertion of organic components substantially enhances its availability for reactants, which, probably, explains multiple increase in the activity observed. Thus, the interlayer organic modification appears to be an effective strategy to manage photocatalytic activity of layered perovskites, which may be applied to other photocatalytically active materials.

#### References

- [1] Schaak R.E., Mallouk T.E. *Chem. Mater.* **2002**, 14, 1455–1471  
[2] Rodionov I.A., Zvereva I.A. *Russ. Chem. Rev.* **2016**, 85, 248–279

Acknowledgements. The study was supported by the Russian Science Foundation (grants № 19-13-00184 and 20-73-00027). The authors are grateful to the Saint Petersburg State University Research Park: Centre for X-ray Diffraction Studies, Centre for Optical and Laser Materials Research, Centre for Chemical Analysis and Materials Research, Centre for Thermal Analysis and Calorimetry, Interdisciplinary Centre for Nanotechnology, Centre for Innovative Technologies of Composite Nanomaterials.

*Latch E.A.<sup>1,2</sup>, Lobova N.A.<sup>1,2</sup>, Aleksandrova N.A.<sup>2</sup>, Vedernikov A.I.<sup>2</sup>, Gromov S.P.<sup>1,2</sup>*

<sup>1</sup>Moscow Institute of Physics and Technology, Moscow, Russia

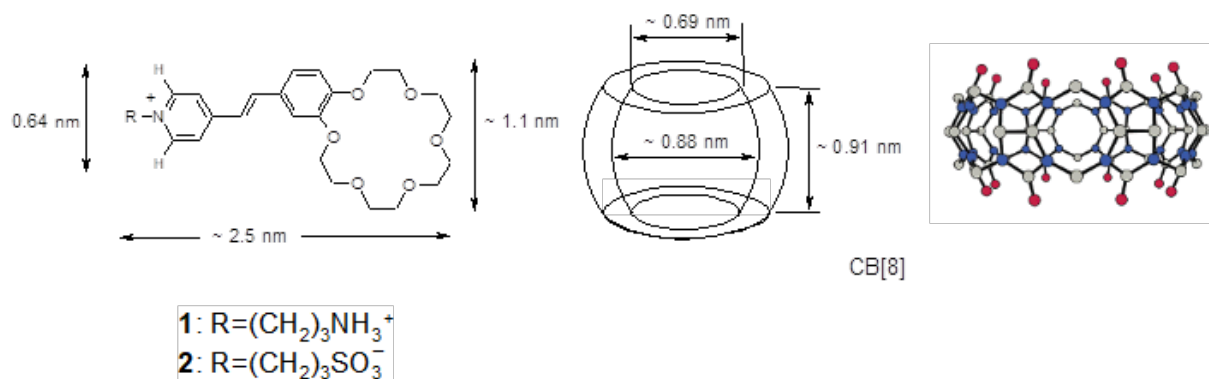
<sup>2</sup>Photochemistry Center RAS, FSRC "Crystallography and Photonics" RAS, Moscow, Russia

Ph.D Student

[lizette\\_latch@email.su](mailto:lizette_latch@email.su)

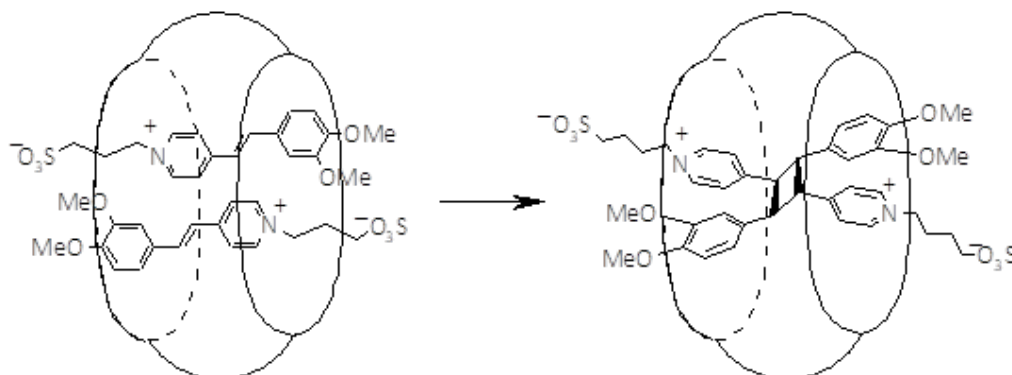
The research objects are crown-containing styryl dyes derivatives **1** and **2** (fig. 1) differing in charge of *N*-substituent. Dicationic dye **1** in aprotic solvent (MeCN) forms dimeric pairs due to hydrogen bonding between terminal ammonium substituent and oxygen atoms in crown-ether residue [1]. Sulfonatoalkyl compound **2** shows high solubility in water due to betaine structure; this allows exploring it in aqueous solutions.

Cucurbit[7,8]urils (CB[7,8]) are macrocyclic compounds that consist of 7 or 8 glycoluril units. Owing to hydrophobic cavity these molecules can form inclusion complexes with styryl dyes [2]. We examined stability and spectral properties of **1** and **2** complexes with CB[7] or CB[8] of different ratio.



**Figure 1.** Structures of components of the supramolecular system and their sizes (X-ray data).

Upon visible-light irradiation dimeric pairs of styryl dyes are able to undergo [2+2]-photocycloaddition. In case of **1** this reaction proceeds in polycrystalline films [1]. It was proven [2] that dimethoxy-substituted analogues of **2** with lower steric volume of aromatic fragment (**3**) form stable inclusion complexes with CB[8] of 2:1 ratio in aqueous solutions and subsequently undergo [2+2]-photocycloaddition inside its cavity (fig. 2).



**Figure 2.** [2+2]-photocycloaddition of  $3_2@CB[8]$ .

We found out that this reaction does not proceed with **2** in solutions in presence of CB[8]. Thus, we propose an approach to controlling the course of the photoreaction by introducing the substituent of required properties into the molecule.

#### References

- [1] Gromov S.P., et al. *J. Org. Chem.* **2014**, 79, 11416–11430  
[2] Gromov S.P., et al. *Eur. J. Org. Chem.* **2010**, 2587–2599

*Levkevich E.A.<sup>1,2</sup>, Zakalyukin R.M.<sup>1,2</sup>, Kumskov A.S.<sup>1</sup>*

<sup>1</sup> Federal Scientific Research Centre «Crystallography and Photonics»  
of Russian Academy of Sciences, Moscow, Russia

<sup>2</sup> MIREA-Russian Technological University, Moscow, Russia  
PhD Student

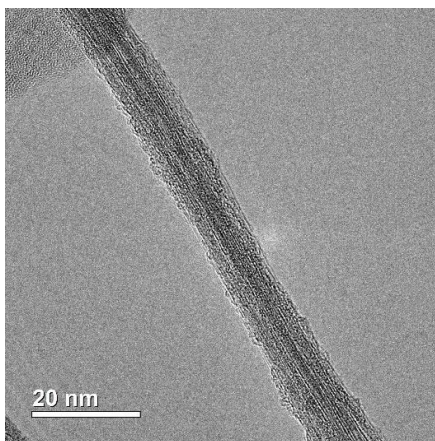
[levkevich.k@crys.ras.ru](mailto:levkevich.k@crys.ras.ru)

The introduction of various types of compounds into the internal channels of single-walled carbon nanotubes (SWCNTs) and studying of the properties of nanocomposites synthesized is of considerable practical and fundamental scientific interest. From the point of view of practice, such nanocomposites lead to a directed modification of the properties of pristine SWCNTs and can be applied in micro- and nanoelectronics. From the point of view of fundamental science, the study of the structure of quasi-one-dimensional crystals in the channels of nanotubes reveals the features of their structure at the nanoscale, which often differs from the structure of a bulk crystal. During crystallization of the eutectic composition two phases are formed, which have different structures and, as a consequence, properties.

A nanocomposite  $E(\text{SbI}_3\text{-Sb}_2\text{S}_3)\text{@SWCNT}$  was synthesized by capillary wetting technique from the melt for the first time. We used ~72 mol.%  $\text{Sb}_2\text{S}_3$  18 mol.%  $\text{SbI}_3$  composition, which corresponds to high-temperature eutectic of  $\text{SbI}_3\text{-Sb}_2\text{S}_3$  phase system. A test charge of antimony sulfide and antimony iodide (high purity) with total mass of ~250 mg and 5 mg of SWCNT (OCSiAl) was ground in a jasper mortar and placed in a quartz ampoule. The sample was subjected to thermos-vacuum treatment (98°C, 2.66 Pa) during 45 min. Then the ampoule was sealed under the vacuum and placed in a muffle furnace, where was heated at the temperature 410°C during three weeks with the subsequent cooling.

The sample obtained was investigated by means of transmission electron microscopy (TEM), powder X-Ray diffraction analysis (XRD) and Raman spectroscopy. TEM was carried out with the FEI Osiris electron microscope, accelerating voltage 200 kV. XRD was carried out with XRD-6000 Shimadzu diffractometer. Powder diffraction pattern was recorded in the  $2\theta$  angle range  $10^\circ\text{--}60^\circ$  in  $0.02^\circ$  steps. The experimental parameters were: 1s exposure time per point,  $\text{CuK}\alpha$  radiation. Raman spectra were taken in the frequencies range  $150\text{--}3500\text{ cm}^{-1}$  with the red laser radiation (671 nm).

There are bundles of SWCNT with mean diameter ~2 nm continuously filled with ordered packing of atoms are observed on the TEM-micrograph (fig.1). Analysis of the XRD pattern proved the presence of two phases:  $\text{SbI}$  ( $Pnam$ ,  $a = 8.53(6)\text{ \AA}$ ,  $b = 10.1(5)\text{ \AA}$ ,  $c = 4.10(7)\text{ \AA}$ ) and  $\text{Sb}_2\text{S}_3$  ( $Pbnm$ ,  $a = 11.26(3)\text{ \AA}$ ,  $b = 11.32(7)\text{ \AA}$ ,  $c = 3.84(5)\text{ \AA}$ ). Upon excitation of SWCNTs of the diameter 2 nm by a laser with an energy of 1.85 eV, semiconductor nanotubes are in resonance. After their filling the shifts of  $G_{LO}$  and  $G_{TO}$  components by  $+9.33\text{ cm}^{-1}$  and  $+1.86\text{ cm}^{-1}$  respectively are observed. D-bands, which indicate the changes in the structure of nanotubes, are also right-shifted by  $+7.63\text{ cm}^{-1}$  after the filling.



**Figure 1.** TEM micrograph of  $E(\text{SbI}_3\text{-Sb}_2\text{S}_3)\text{@SWCNT}$  nanocomposite.

The SWCNT channels were filled with the eutectic composition of the  $\text{SbI}_3\text{-Sb}_2\text{S}_3$  system. It was confirmed by TEM, XRD, and Raman spectroscopy. According to the data of the latter one, the inserted compound acts like an electron acceptor in relation to the shell of the carbon nanotube.

**Acknowledgements.** This work was performed using the equipment of the Shared Research Centre of the Federal Scientific Research Centre «Crystallography and Photonics» of Russian Academy of Sciences with support of the Ministry of Science and Higher Education of Russian Federation (project no. RFMEFI62119X0035).



# HIGH RATE LASER DEPOSITION OF NICKEL-GRAPHENE OXIDE COMPOSITES FROM DEEP EUTECTIC SOLVENTS

*Levshakova A.S., Gordeychuk D.I., Khairullina E.M., Panov M.S., Shishov A.Yu., Tumkin I.I.*

Saint-Petersburg State University,  
Institute of Chemistry, Saint-Petersburg, Russia  
2 year PhD student  
[sashkeens@gmail.com](mailto:sashkeens@gmail.com)

Technique of laser-induced deposition from deep eutectic solvents (DES) opens up possibilities for the fabrication of conducting structures on dielectric substrates for microelectronics and sensor applications. The use of deep eutectic solvents greatly simplifies the metal deposition procedure and increases the reaction rate by at least two orders of magnitude in comparison with the use of aqueous solutions [2].

Laser-assisted deposition of composite materials based on Ni / graphene oxide (GO) using a deep eutectic solvents on an oxide glass substrate was demonstrated for the first time. Nickel chloride and graphene oxide were used as a precursor for laser thermo-induced synthesis, a method for the fabrication of DES based on choline chloride, citric acid and graphene oxide was developed. DES serves as both a solvent and a metal reducing agent [1]. The laser irradiation of this solution leads to the formation of highly conductive nanostructured coatings on the glass surface. GO additives were varied in a range from 0 to 50 mass percent to study the composition, morphology and electrocatalytic properties of deposits. DES with nickel chloride and GO was uniformly distributed over the surface of the slide by spin coating, and the substrate was irradiated with a diode-pumped solid-state Nd: YAG laser (CW, 532 nm) to fabricate the nickel/GO microstructures. The synthesized materials were analyzed using a scanning electron microscope and X-ray diffraction (Fig. 1 (a, b)). According to SEM data, all structures are continuous films, which should provide a stable electrical contact during electrochemical studies. The determination of the qualitative composition was carried out by the methods of X-ray powder diffraction and EDX, the deposits consist of two phases - nickel and graphite.

Also, the electrocatalytic properties of the synthesized materials in the reaction of glucose electrooxidation were investigated by the methods of cyclic voltammetry (CV) and chronoamperometry (CA). The Ni-based electrode exhibits two linear regions on the calibration curve (Fig. 1 (c)), in contrast to the Ni-GO electrode. It should be noted that the Ni-40% GO electrode with the most developed surface exhibits the highest sensitivity among all synthesized materials within the glucose concentration range of up to 12.5 mM. It is shown that the modification of electrodes with graphene oxide makes it possible to increase the analysis sensitivity and detection limits of glucose detection.

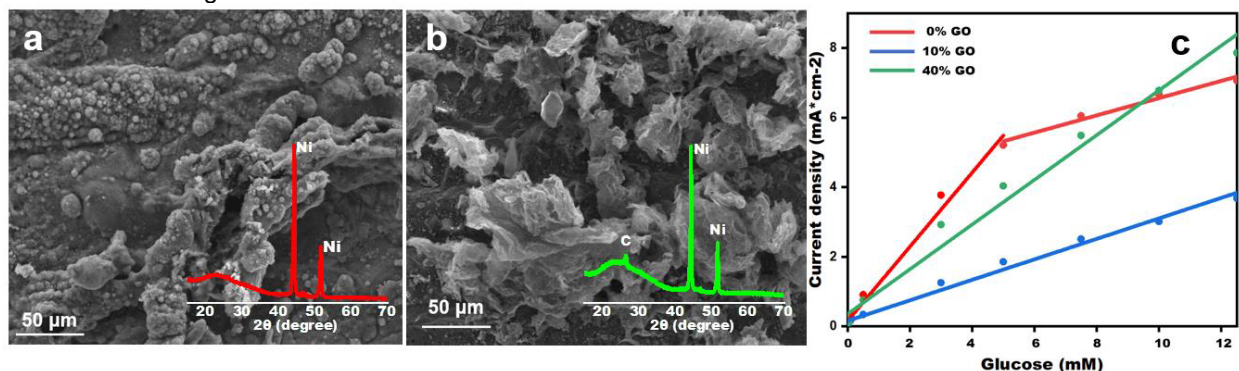


Fig. 1. SEM image and XRD patterns of electrode containing 0 (a) and 40 (b) mass % graphene oxide, (c) Linear ranges of enzymatic detection of D-glucose on Ni and Ni-GO electrodes

## References

1. Andrew P. Abbott, et. al. Solubility of Metal Oxides in Deep Eutectic Solvents Based on Choline Chloride // Journal of Chemical & Engineering Data, 2006, 51, 4, 1280–1282
2. A. Shishov, D. Gordeychuk, L. Logunov, I. Tumkin. High rate laser deposition of conductive copper microstructures from deep eutectic solvents // Chem. Commun., 2019, 55, 9626.

Acknowledgements. This work was supported by by RFBR (20-33-70277) and Grants Council of the President of the Russian Federation (project MK-1521.2020.3). The authors also express their gratitude to the SPbSU Nano-technology Centre, the Centre for Optical and Laser Materials Research and the Centre for X-ray Diffraction Studies.

## SYNTHESIS OF COPPER NANOPARTICLES IN LIPOSOMES

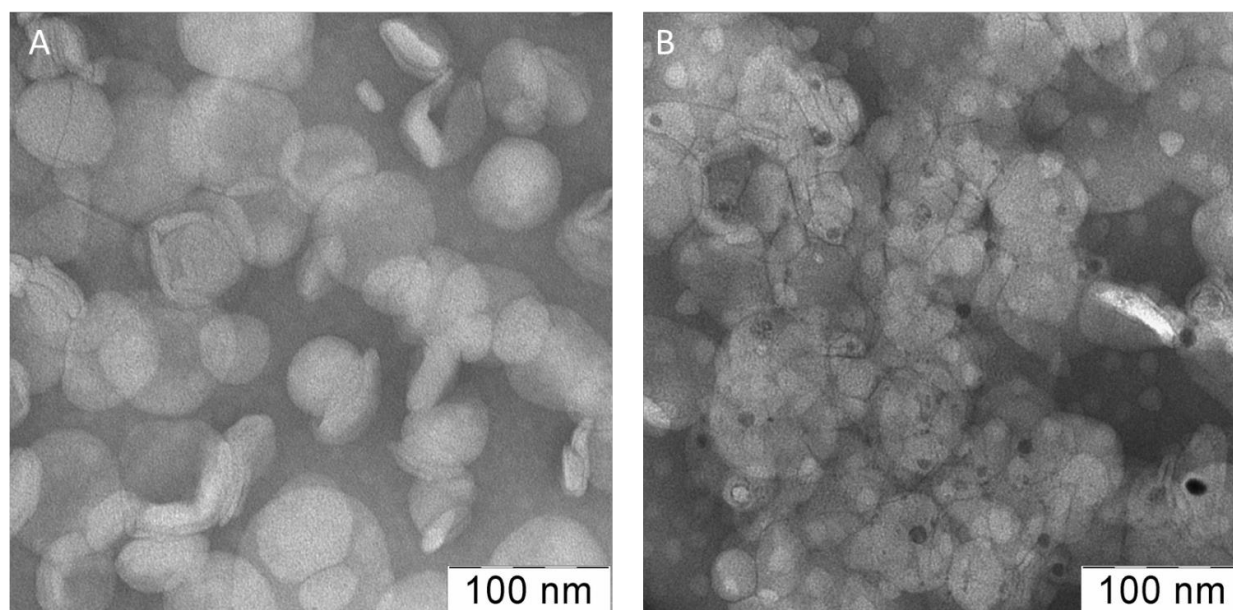
*Livshitz S.O., Zaborova O.V., Sergeyev V.G.*

Moscow State University, Moscow, Russia  
Student  
[s.livshitz05@gmail.com](mailto:s.livshitz05@gmail.com)

Metal nanoparticles are used in a wide range of applications due to their unique properties. Copper and other metal nanoparticles, such as gold and silver, can be used in biomedicine for drug delivery and diagnostics. Copper nanoparticles also possess the antimicrobial properties. There are several different approaches to synthesize metal nanoparticles, and electrochemical and chemical reduction are the most popular ones. Regardless of the chosen method, nanoparticles need to be stabilized to prevent aggregation and sedimentation. Copper nanoparticles also tend to oxidize [1].

One way to stabilize metal nanoparticles is to incorporate them into liposomes – lipid bilayer vesicles. There are two approaches to incorporate metal nanoparticles into the liposome. First, is to mix liposomes with pre synthesized nanoparticle. However, this method has several disadvantages. Resulting mixture should be separated from free nanoparticles and empty liposomes. Moreover, metal nanoparticles can cause the disruption and fusion of liposomes after mixing. Second approach is to synthesize metal nanoparticles directly in the inner cavity of liposome [2].

In this work we investigated the formation of copper nanoparticles in liposomes. For this we added different reducing agents (such as hydrazine, sodium citrate, sodium borohydride, citric acid, and ascorbic acid) to liposomes loaded with  $\text{CuSO}_4$  solution. The formation of copper nanoparticles was confirmed by spectrophotometry and transmission electron microscopy (TEM).



**Figure 1.** Microphotographs from TEM for liposomes loaded with copper sulfate solution before (A) and after (B) addition of the reducing agent.

### References

- [1] Vargas K.M., Shon Y.-S. *J. Mater. Chem. B*, **2019**, 7, 695–708
- [2] Lee J-H., Shin Y., Lee W., Whang K., Kim D., Lee P., Choi J., Kang T. *Sci. Adv.* **2016**, 2, e1601838

Acknowledgements. This work was supported by the Russian Science Foundation (project No 21-73-20144)

# HIGHLY ORDERED NANOSTRUCTURES AND THEIR IMPLEMENTATION IN TRANSPARENT ELECTRODES FOR OPTO-ELECTRONIC APPLICATIONS

*Döhler D.<sup>1</sup>, Triana A.<sup>1</sup>, Büttner P.<sup>1</sup>, Scheler F.<sup>1</sup>, Goerlitzer E.S.A.<sup>1</sup>,  
Harrer J.<sup>1</sup>, Vasileva A.<sup>1</sup>, Metwalli E.<sup>1</sup>, Gruber W.<sup>1</sup>, Unruh T.<sup>1</sup>,  
Manshina A.<sup>2</sup>, Vogel N.<sup>1</sup>, Bachmann J.<sup>1,2</sup>, and Mínguez-Bacho I.<sup>1</sup>*

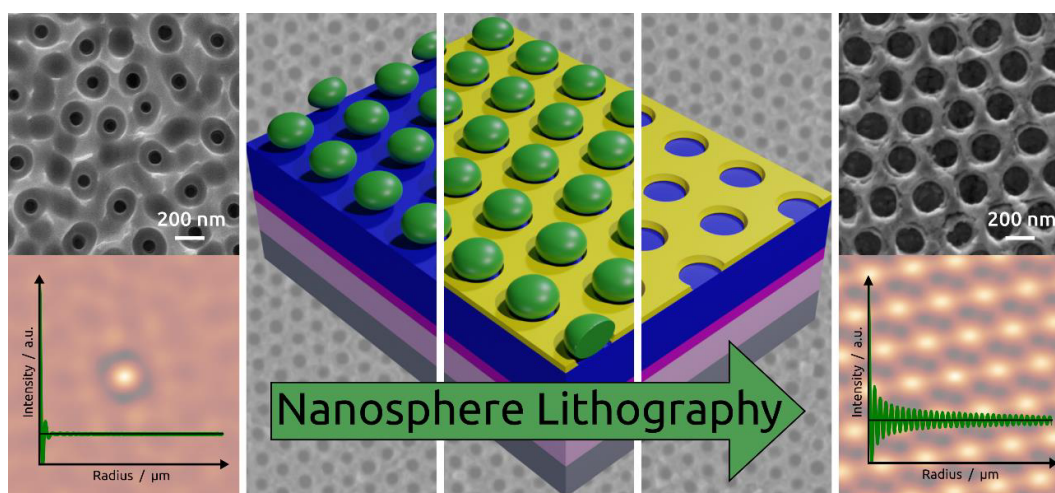
<sup>1</sup>Friedrich-Alexander University Erlangen-Nürnberg, Erlangen, Germany

<sup>2</sup>Saint Petersburg State University, Saint Petersburg, Russia,

Young Investigator

[ignacio.minguez@fau.de](mailto:ignacio.minguez@fau.de)

We present the preparation of a highly ordered nanostructured transparent electrode based on a combination of nanosphere lithography and anodization. The size of perfectly ordered pore domains is improved by an order of magnitude with respect to the state of the art. The concomitantly reduced density of defect pores increases the fraction of pores that are in good electrical contact with the underlying transparent conductive substrate. This improvement in structural quality translates directly and linearly into an improved performance of energy conversion devices built from such electrodes in a linear manner [1-2].



**Figure 1.** Highly ordered nanoporous transparent electrodes fabricated via nanosphere lithography and anodization is presented. Perfect hexagonal order over domains of thousands of square micrometer is achieved using self-assembly methods exclusively. Solar cells made from them reach significantly improve performance compared to their disordered counterparts.

## References

- [1] D. Döhler, A. Triana, P. Büttner, F. Scheler, E. S. A. Goerlitzer, J. Harrer, A. Vasileva, E. Metwalli, W. Gruber, T. Unruh A. Manshina, N. Vogel, J. Bachmann, I. Mínguez-Bacho\*. A Self-Ordered Nanostructured Transparent Electrode of High Structural Quality and Corresponding Functional Performance *Small*. 2021, DOI: 10.1002/smll.202100487.
- [2] I. Mínguez-Bacho, F. Scheler, P. Büttner, K. Bley, N. Vogel and J. Bachmann "Ordered Nanopore Arrays with Large Interpore Distance via One-Step Anodization" *Nanoscale* 2018, 8385.

**Acknowledgements.** This work was funded by the European Commission via a Marie Skłodowska-Curie Grant ('Hybricyl', grant agreement 795716), by the European Research Council with a Consolidator Grant ('Solacylin', grant agreement 647281), by the Deutsche Forschungsgemeinschaft (DFG, German Research Foundation) in its Coordinated Research Center 'CLINT' (SFB 1452, project 431791331), by a bilateral Russian Foundation for Basic Research-DFG project (RFBR 20-58-12015, DFG 429730598) and "Physics Educational Centre" of Research Park of Saint Petersburg State University for technical support.

# A SINGLE MAGNETIC PARTICLE WITH NEARLY UNLIMITED ENCODING OPTIONS

Müssig S.<sup>1</sup>, Reichstein J.<sup>1</sup>, Prieschl J.<sup>1</sup>, Wintzheimer S.<sup>1</sup>, Mandel K.<sup>1,2</sup>

<sup>1</sup>Friedrich-Alexander University Erlangen-Nürnberg (FAU), Erlangen, Germany

<sup>2</sup>Fraunhofer Institute for Silicate Research ISC, Würzburg, Germany

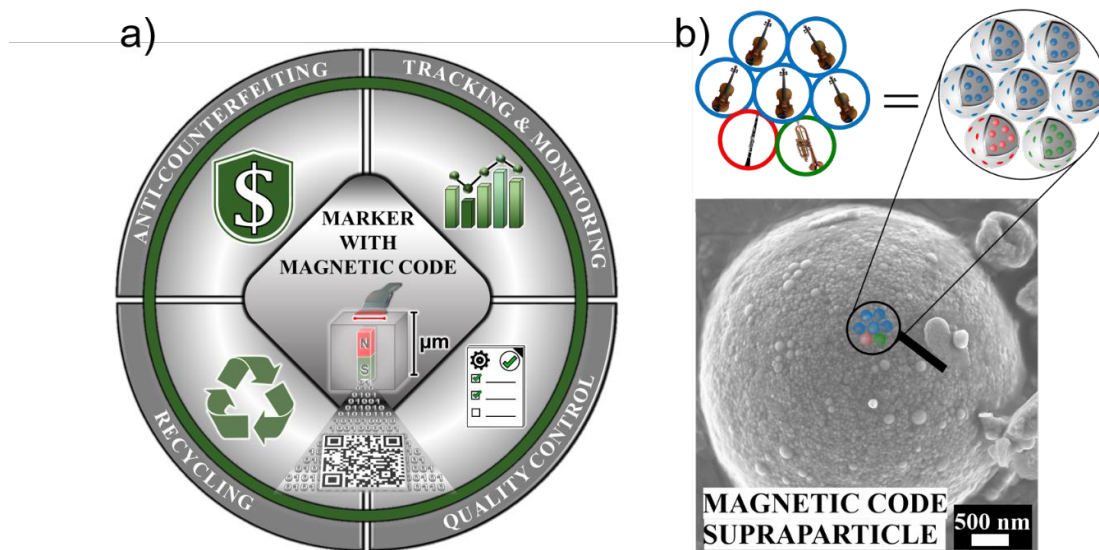
[karl.mandel@fau.de](mailto:karl.mandel@fau.de)

Ever more complex global resource and supply chains cause the necessity to develop approaches that enable marking and tracing of materials and products. Well-established marking systems such as barcodes or RFID-chips cannot fulfill the necessary requirements such as being sufficiently small, secure against counterfeiting and above all, these technologies cannot be integrated into arbitrary materials. Thus, employing particles as markers for object tracing appears to be a promising approach to overcome the drawbacks of RFID and barcode labels. [1, 2]

Going beyond optical signal carriers, magnetic signals can be transmitted through many materials that would not allow optical information to pass. Thereby, objects in different application fields could be equipped with such a smart additive (Fig. 1a).

In this presentation we show that nanostructured micron-sized particles (so called supraparticles) have the potential to be *spectrally* encoded with more than 77 billion magnetic codes and thereby render an all magnetic ID possible [3].

The humongous amount of distinguishable magnetic codes is achieved by a multihierarchical supraparticle design. On a first level, different nanocomposite particles, containing one type of magnetic nanoparticle each and a polymer, are synthesized. On a second level, the different nanocomposite particles are assembled into supraparticles with freely chosen ratios via spray-drying. The different structures yield different magnetic codes which are sensitively resolved by the relatively unknown technique called magnetic particle spectroscopy. The concept is vividly presented in analogy to the principle of a musical ensemble (Fig. 1b). [3]



**Figure 1.** An intelligent magnetic particle with a unique code turns arbitrary objects into communicating items. Magnetic materials are environmentally-friendly, inexpensive and, most importantly, their signal is unaffected by optical constraints so that read-out is possible even if the marker is hidden within objects. This grants access to a vast variety of unexploited marking applications (a). The structure of the code carrying supraparticle can be freely changed just like the line-up of an musical ensemble (b). [3]

## References

[1] Wintzheimer, Reichstein J. et. al., Supraparticles for sustainability. *Advanced Functional Materials* **2021**, 2011089.

[2] Shikha S., Salafi T. et. al., Versatile design and synthesis of nano-barcodes. *Chem. Soc. Rev.* **2017**, 46, 7054

[3] Müssig S., Reichstein J. et. al., A single magnetic particle with nearly unlimited encoding options. *Small*, just accepted

This work was financially supported by the BMBF NanoMatFutur Grant 03XP0149 and the PhD scholarships for Stephan Müssig and Jakob Reichstein from the German Federal Environmental Foundation.

# AIR-FILLED ALBUMIN MICROBUBBLES STABILIZED WITH GOLD NANOPARTICLES AND PHOTODYNAMIC DYE FOR THERANOSTICS DEMANDS

*Maksimova E.A., Barmin R.A., Rudakovskaya P.G., Gorin D.A.*

Skolkovo Institute of Science and Technology, Moscow, Russia

Student

Elizaveta.Maksimova@skoltech.ru

Nowadays, ultrasound (US) imaging is one of the most frequently used clinically available methods for diagnostics with more than 40 years of implementation due to the simplicity and low cost of the procedure and the absence of contraindications. [1] Over recent decades, plenty of microbubbles-based agents have been widely investigated and involved in clinical practice as US contrast agents due to their good acoustic properties. The present research considers bovine serum albumin (BSA) as the main shell component of microbubbles due to its sufficient concentration in the blood plasma and subsequent high biocompatibility.

Moreover, modification of the bubbles' shell is needed to produce probes for multimodal (ultrasound/photoacoustic) imaging in combination with photodynamic therapy of cancer. In the present work, hybrid structures based on microbubbles with an air core and a shell composed of bovine serum albumin, albumin-coated gold nanoparticles of different morphology (spheres, cages, rods), and clinically available photodynamic dye (zinc phthalocyanine) were prepared using the sonication method and characterized. The combination of gold nanoparticles and photodynamic dyes' influence on the fluorescent signal and probes' stability is described. The potential use of the obtained probes in biomedical applications was evaluated using fluorescence tomography, raster-scanning optoacoustic microscopy and ultrasound response measurements. The results demonstrate the impact of microbubbles' stabilization using gold nanoparticle/photodynamic dye hybrid structures to achieve probe applications in theranostics.

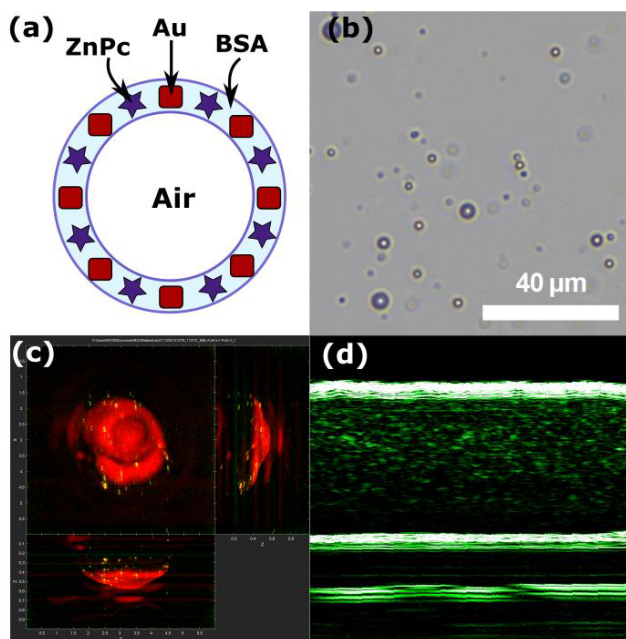


Figure 1. (a) Schematic representation of microbubble structure; (b) optical microscopy image of freshly prepared multimodal microbubbles; (c) optoacoustic response of gold nanoparticles implemented to the MBs shell; (d) ultrasound response of multimodal MBs

## References

- [1] Wells, P. N. T. (2006). *Ultrasound imaging. Physics in Medicine and Biology*, 51(13), R83–R98.
- [2] Van Rooij, T., Daeichin, V., Skachkov, I., de Jong, N., & Kooiman, K. (2015). *Targeted ultrasound contrast agents for ultrasound molecular imaging and therapy. International Journal of Hyperthermia*, 31(2), 90–106.

Acknowledgements. This work was supported by the Russian Foundation for Basic Research (RFBR grant 19-53-80047 BRICS\_t). Measurements were performed using the equipment of the “Bioimaging and Spectroscopy” Core Facility of the Skolkovo Institute of Science and Technology.

STUDY OF THE SOL-GEL PROCESS BASED ON WATER-SOLUBLE PRECURSOR  
BY MEANS OF FLUORESCENT, SAXS AND EPR METHODS

Medvedeva A.A.<sup>1</sup>, Ionova I.V.<sup>1</sup>, Shtykova E.V.<sup>2</sup>, Koshkin A.V.<sup>1</sup>

<sup>1</sup>"Photochemistry Center" RAS, FSRC "Crystallography and Photonics" RAS, Moscow

<sup>2</sup>"Institute of Crystallography" RAS, FSRC "Crystallography and Photonics" RAS, Moscow

PhD Student

[Medvedeva.mipt@gmail.com](mailto:Medvedeva.mipt@gmail.com)

Despite the widespread use of silicate materials obtained by the method of sol-gel synthesis in various fields and technologies, today there is no unified concept of the formation of a solid phase from various initial compounds. The current situation is explained by a large number of factors influencing the gelation process (pH, surface potential, temperature, etc.). In addition, various catalysts and by-products released during the process have a large impact on the effect and properties of materials.

In this work, we studied the processes occurring during the formation of silicate hydrogels based on the water-soluble THEOS [1] precursor, which doesn't require the use of acidic or basic catalysts for the sol-gel process. This allows the process to be carried out under mild conditions in substances that are sensitive to pH, for example, complex supramolecular complexes or other compounds built using non-covalent interactions. For the study, the methods of fluorescence spectroscopy, small-angle X-ray scattering and electron paramagnetic resonance were used.

Styryl dye 4-DASPI was chosen as a fluorescent probe, since its quantum yield strongly depends on the viscosity of the microenvironment of the medium [2], the position of the maximum strongly depends on the polarity of the medium. These features make it possible to study the process of sol-gel synthesis at the molecular level. To study the dynamics of the formation of the solid phase, the method of small angular X-ray scattering and electron paramagnetic resonance was used. Using the first method, data were obtained on the kinetics of the growth of silicate nanoparticles on the surface of hydrosol formation; using the second method, information was obtained on the behavior of impurity probe molecules on the surface of these particles and the processes occurring during the aging of the hydrogel.

Based on the totality of the data obtained, changes in the fluorescence intensity of 4-DASPI in the process of sol-gel synthesis were correlated with the stages of the growth of the solid phase. It was found that the silicate hydrogel matrix is formed from particles with a size of about 20-22 nm within 6-8 hours. The mechanism of the formation of a solid silica gel matrix at the base of impurity molecules 1 was established, while the occurrence of two sorption types of probe molecules on colloidal sol particles was proved, due to the binding of probes to the surface and the capture of nanoparticles that form the solid phase into the bulk.

### References

- [1] Y. A. Shchipunov, T. Y. Karpenko, I. Y. Bakunina, Y. V. Burtseva, T. N. Zvyagintseva *J. Biochem. Biophys. Methods* **2004**, *58*, 25–38  
[2] M. Haidekker, E. Theodorakis *Journal of Biological Engineering* **2010**, *4*, 1-14

*Medvedev V.A.<sup>1</sup>, Mamonova D.V.<sup>1</sup>, Kolesnikov I.E.<sup>1</sup>, Mikhailov M.D.<sup>2</sup>, Manshina A.A.<sup>1</sup>*

<sup>1</sup>Saint Petersburg State University, Saint Petersburg, Russia

<sup>2</sup>Peter the Great St.Petersburg Polytechnic University, Saint Petersburg, Russia  
[st063851@student.spbu.ru](mailto:st063851@student.spbu.ru)

This work is devoted to the synthesis and study of nanocrystalline particles containing rare earth ions (REI). Metal oxides are the most promising compounds for doping with lanthanides due to their chemical inertness and stability of physicochemical properties in a wide temperature range. These factors allow using such materials for medical purposes (due to their biocompatibility), in mechanical engineering, instrumentation and marking (due to their heat resistance and hardness), etc.

The luminescence properties of rare earth ions depend on the crystal lattice, synthesis conditions, type of ions and their concentration. Each rare earth ion placed in a specific host exhibits a set of luminescence bands with corresponding spectral positions and relative intensities. In addition, the doping REIs are capable of transferring excitation energy to each other (Fig. 1). The material doped with a group of rare earth ions is a unique system. This allows the use of particles of complex oxides doped with REIs as luminescent protective markers with unique properties.

For the synthesis of nanocrystalline particles, a modified Pechini method was used [1]. In this method, an amorphous powder is prepared by the standard Pechini method and then calcined in a molten salt at a high temperature. This method leads to the formation of particles of a homogeneously doped weakly agglomerated oxide with a well-organized crystal structure. Weak agglomeration and the presence of small particles make it possible to obtain stable colloidal solutions and suspensions.

The luminescent properties of YVO<sub>4</sub> powders doped with various types and concentrations of rare earth ions (Nd, Tm, Er) have been studied. It was found that energy transfer between REIs takes place [2]. The luminescence kinetics, lifetimes and energy transfer efficiency have been studied. The results of phase composition (XRD), parameters of crystalline unit cells, morphology (SEM), particle size distribution (SLS) were also obtained.

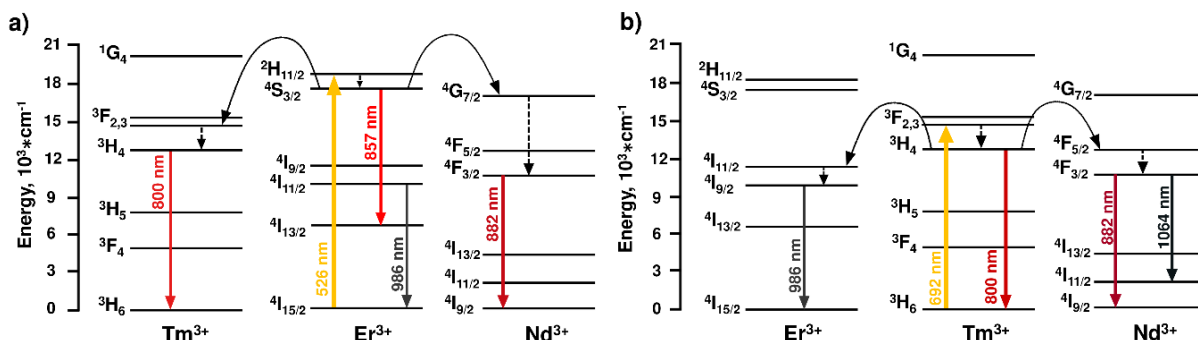


Figure 1. Scheme of energy transfer between rare earth ions in YVO<sub>4</sub> structure a) from Er<sup>3+</sup>; b) from Tm<sup>3+</sup>.

## References

- [1] Mamonova D. V et al. Modified Pechini method for the synthesis of weakly-agglomerated nanocrystalline yttrium aluminum garnet ( YAG ) powders // Mater. Chem. Phys. Elsevier B.V, 2017. Vol. 189. P. 245–251.
- [2] Medvedev V.A. et al. Synthesis and luminescence properties of YVO<sub>4</sub>: Nd<sup>3+</sup>, Er<sup>3+</sup> and Tm<sup>3+</sup> nanoparticles // Inorg. Chem. Commun. Elsevier, 2020. Vol. 118, № May. P. 107990.

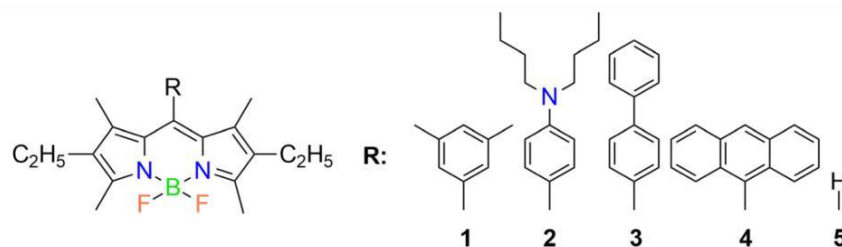
Acknowledgements. Authors are grateful to “Interdisciplinary Resource Centre for Nano-technology”, Resource Center “Innovative technologies of composite nanomaterials”, “Thermogravimetric and Calorimetric Research Centre”, “Research Centre for X-ray Diffraction Studies” and “Centre for Optical and Laser Materials Research” of Saint-Petersburg State University Research Park. The authors are grateful to “Russian president grant” № MK-1306.2020.3

## CONCENTRATION EFFECTS ON BODIPY AGGREGATION

*Merkushev D.A.<sup>1</sup>, Banakova E.A.<sup>1</sup>, Usoltsev S.D.<sup>1</sup>, Marfin Yu.S.<sup>1</sup>*

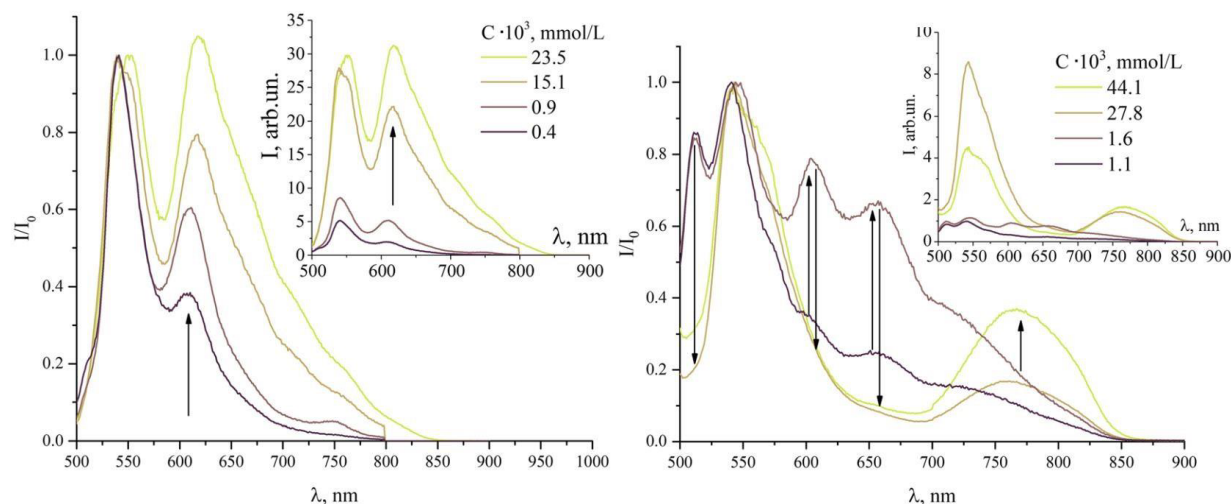
<sup>1</sup>Ivanovo State University of Chemistry and Technology, Ivanovo,  
Russia Graduate student  
[merkushev@isuct.ru](mailto:merkushev@isuct.ru)

The study of luminescent materials is usually carried out in diluted solution to avoid concentration effects. This approach limits the freedom of research due to complex nature of aggregation processes and unpredictability of spectral changes. Some approaches have been invented to understand the nature of aggregation [1-2]. Despite significant progress in understanding of dye aggregation, there are still processes that need to be further explored and which can significantly affect aggregation. In this work several BODIPYs of different nature were used: 1, 2, 3 are molecular rotors, 4, 5 are not.



**Figure 1.** Investigated BODIPYs.

It was found that the aggregation of dyes is influenced not only by dye concentration, but also by solvent polarity. It was found that nature, positions and number of fluorescent peaks may be controlled by simultaneous varying of both water fraction and dye concentration.



**Figure 2.** Normalized and absolute (insets) fluorescence spectra of compound 4 (left) (not molecular rotor) and 3 (right) (molecular rotor) in the THF-water mixture with a THF fraction of 5 vol% at various dye concentrations.

This effect is the most pronounced for molecular rotors, which aggregates' geometry may be stabilized in different separate states depending on the aggregation degree. The concentration effect plays a significant role in dye aggregation and should be considered in new studies in order to prevent misinterpretation or to obtain new results in fields of molecular sensing or fine-tuning of fluorescence color.

### References

- [1] Zhao, Z., Zhang, H. *Angewandte Chemie International Edition*, **59**(25), 9888-9907.
- [2] Yuan, W. Z., Lu, P. *Advanced materials*, **22**(19), 2159-2163.

Acknowledgements. This work was supported by the Russian Science Foundation (project No 19-73-10107).



# A SUPRAPARTICLE-BASED FIVE-LEVEL-IDENTIFICATION TAG THAT SWITCHES INFORMATION UPON READOUT

Miller F.<sup>1</sup>, Prieschl J.<sup>1</sup>, Wintzheimer S.<sup>1</sup>, Strauss V.<sup>2</sup>, Mandel K.,<sup>1,3</sup>

<sup>1</sup>Friedrich-Alexander University Erlangen-Nürnberg (FAU), Erlangen, Germany

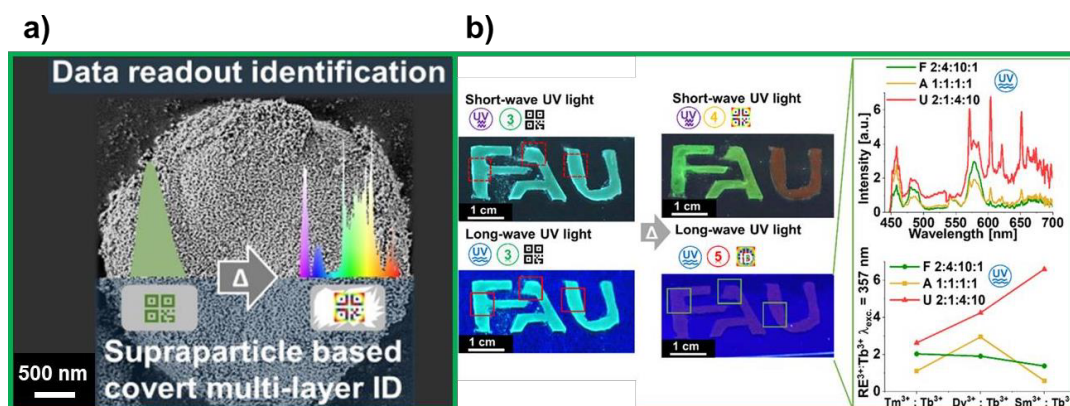
<sup>2</sup>Max Planck Institute of Colloids and Interfaces, Potsdam, Germany

<sup>3</sup>Fraunhofer Institute for Silicate Research ISC, Würzburg, Germany  
[karl.mandel@fau.de](mailto:karl.mandel@fau.de)

Secure authentication of product components is of great importance in times of constantly growing, non-transparent global trading networks. Beyond currently used coding strategies, such as QR codes or RFID chips, flexible application, higher data density as well as miniaturization and readout indication are longed for in the next generation of anti-counterfeiting security tags. For this reason, employing particle-based markers and tracers has been suggested to enable greater flexibility and the possibility to label even smallest product sub-components and increase the security level.<sup>[1,2]</sup>

Within the herein presented work, hierarchically structured micron-sized supraparticles with encoded information were produced that not only exhibit multiple initially covert levels of identification but are also irreversibly marked as „read“ upon readout.

To achieve this, based on a modular approach, lanthanide doped CaF<sub>2</sub> nanoparticles were assembled in various quantity-weighted ratios via spray-drying in presence of a broad-spectrum stealth fluorophore, yielding covert spectrally encoded supraparticles. Using these as pigments, QR codes, initially dominated by the green fluorescence of the fluorophore, could be generated. Upon thermal energy input, these particle-based tags irreversibly switch to an activated state revealing not only multiple luminescent colors but also spectral IDs. Furthermore, when arranged as a pattern, these spectrally encoded markers yield a multi-colored spatially encoded tag.<sup>[3]</sup> This strategy provides the next generation of material-based security tags with a high data density and security level that switch information upon readout and can be, therefore, used as seal of approval. Moreover, this unique optical fingerprint can be converted into a numerical code and thus digitized, which is why this smart nanomaterial also has the potential to contribute to the digitization of industrial production and could represent a key innovation for realizing communication within the Internet of Things.



**Figure 1.** Multi-layered optically encoded supraparticles that switch information upon readout: a) SEM image of one supraparticle complemented with a schematic depiction of their functioning principle. b) Photographs of spatially resolved QR-Code like patterns of three ID-supraparticle types, before and after thermal activation (left). Fluorescent spectra performed at the marked areas after thermal activation as well as graphic depiction of relative emission intensity ratios as numerical code of the respective emission peaks.

## References

[1] Paunescu D., Stark W. J. et al., Particles with an identity: Tracking and tracing in commodity products, *Powder Technol.* **2016**, 291, 344-350

[2] Wintzheimer S., Reichstein J. et. al., Supraparticles for sustainability. *Adv. Funct. Mater.* **2021**, 2011089

[3] F. Miller, S Wintzheimer, J. Prieschl, V. Strauss, K. Mandel, A supraparticle-based five-level-identification tag that switches information upon readout *Adv. Optical Mater.* **2020**, 2001972

Acknowledgements: This work was financially supported by the BMBF NanoMatFutur Grant 03XP0149.

NEW SYNTHETIC APPROACHES FOR OCTAHEDRAL CLUSTERS OF MOLYBDENUM,  
TUNGSTEN AND RHENIUM

*Mironova A.D.*<sup>1</sup>, *Sokolov M.N.*<sup>1</sup>

<sup>1</sup>Nikolaev institute of inorganic chemistry, Novosibirsk, Russia

[amironova@niic.nsc.ru](mailto:amironova@niic.nsc.ru)

Transition metals of 6 and 7 groups tend to form octahedral clusters with halide and chalcogenide bridging ligands which can be described by the general formula  $[\{M_6(\mu_3-X)_8\}L_6]^n$ . Phosphorescence in the red region is closely related to the generation of singlet oxygen while the cluster acts as a photosensitizer.  $\{M_6X_8\}^{n+}$  core is known to have Lewis acid properties which opens up some prospects for coordinated ligands modification and also indicates the possibility of catalytic activity of clusters. Searching for the new synthetic methods of controlled ligand environment modification and setting the desired physical properties appears current interest of cluster chemistry. New synthetic approaches complements the traditional methods of ligand exchange and reveal new possibilities for the formation of the desired coordination sphere around the cluster core.

We have modified azide ligands around the  $\{M_6I_8\}^{4+}$  cluster core using the reaction of 1,3-dipolar cycloaddition of alkynes with electron-deficient substituents and aromatic nitriles  $N\equiv C-R$  ( $R = C_6H_5, C_6F_5$ ) with the formation of hexakis(tetrazolate) and (triazolate)complexes [1], [2].

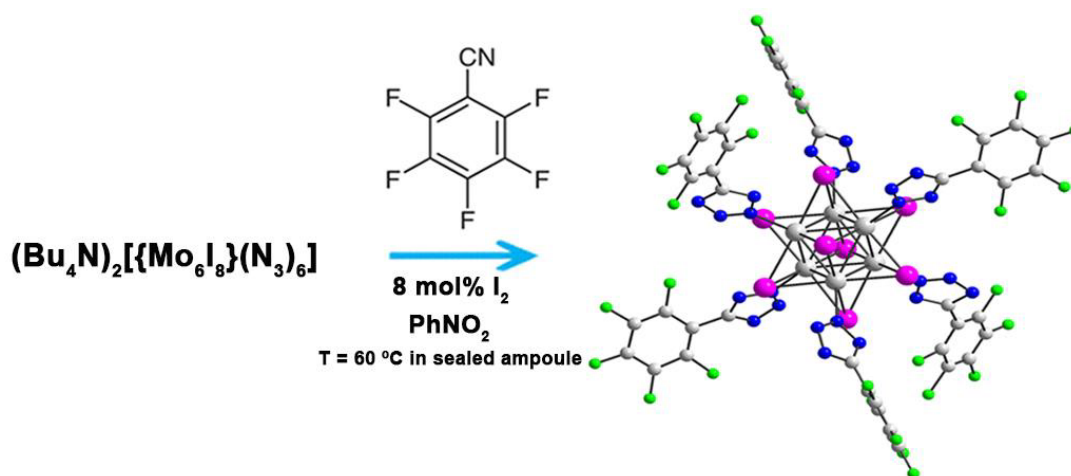


Figure 1. Tetrazolate cluster complexes formation

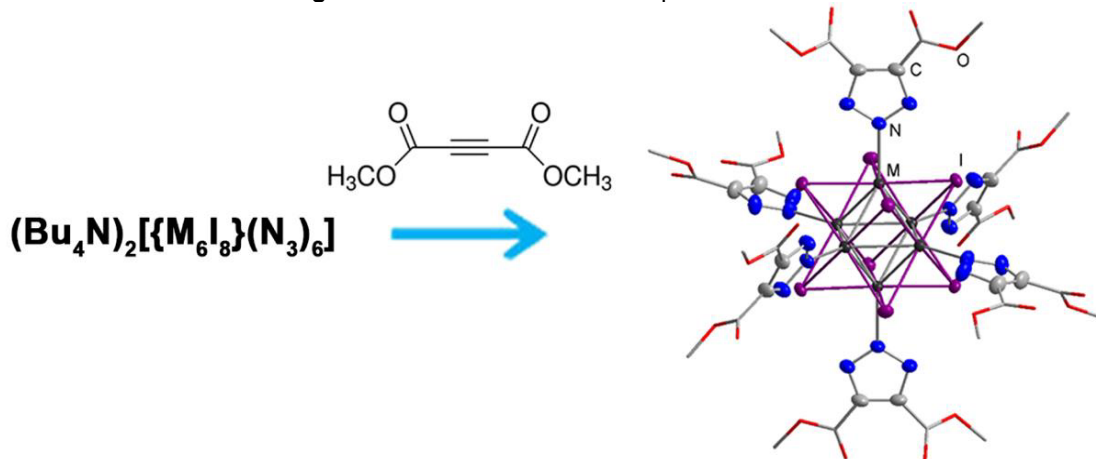


Figure 1. Triazolate cluster complexes formation

#### References

- [1] Mironova A.A., Gushchin A.L. and Sokolov M.N., *Polyhedron*, **2021**, 10.1016/j.poly.2021.115282.  
[2] Mironova A.A, Mikhailov M.A. and Sokolov M.N., *New Journal of Chemistry*, **2020**, 44, 20620-20625.

Acknowledgements. This work was supported by the Russian Foundation for Basic Research (project No 20-03-00410).

# SILICA-MODIFIED POLYMERIC CATALYSTS FOR HEAVY OIL FRACTION CONVERSION IN SUPERCRITICAL SOLVENTS

Monzharenko M.A., Markova M.E., Stepacheva A.A., Matveeva V.G., Sulman M.G.

Tver State Technical University, Tver

PhD Student

[monzharenko.rita@yandex.ru](mailto:monzharenko.rita@yandex.ru)

Conversion of heavy hydrocarbons, particularly polyaromatics, is one of the main tasks in petroleum, coal, and biofuel industries. High polyaromatic content in heavy oil fractions makes it fuel properties inappropriate for use in engines because of high boiling point, high viscosity, and low cetane number [1]. Nowadays, hydroconversion is one of the approaches widely used for the processing of crude oil fractions containing polyaromatics and heterocyclic hydrocarbons to produce light aromatic hydrocarbons. However, this process is characterized by the high hydrogen consumption that decreases the feasibility of the heavy oil conversion [2]. To decrease or minimize the hydrogen consumption, the supercritical approaches can be successfully used. The use of supercritical solvents, in addition to the high conversion of feedstock, leads to a decrease in the viscosity and density of the resulting product, and also prevents coking of the catalysts [3].

In this work, the influence of the supercritical solvent and hydrogen presence on the catalytic hydroconversion of model polyaromatic compounds (naphthalene and anthracene) was studied. Taking into account the existing disadvantages of the hydrocracking catalysts, we developed novel bifunctional systems combined with the high surface area and rigid structure of hypercrosslinked polymers, strong acidity of silica, and the active phase based on metal oxide.

Different alcohols (propanol-2, methanol, ethanol, and their mixtures) in the supercritical state were used for the polyaromatic conversion. The reaction was performed in both hydrogen and inert atmosphere. The experiments showed that the use of supercritical solvents significantly decreases the hydrogen consumption. Hydrogen, in this case, was mainly involved in the hydrogenation of polyaromatics and monoaromatics formed during the cracking. The analysis of the liquid phase after the hydrocracking showed the predominant formation of monoaromatics such as benzene, toluene, xylenes. Besides, the formation of some amounts of dihydroanthracene, tetrahydro anthracene, diphenylethane, tetraline and decaline were observed. The gas-phase analysis showed the formation of methane and ethylene in the presence of silica-containing catalysts. It should be noted that the increase in the acidity of the catalyst resulted in the formation of a higher amount of monoaromatics (in general, toluene).

## References

- [1] Rada M.R., Rashidi A., Vafajoo L., Rashtchi M. *J. Ind. Eng. Chem.* **2014**, *20*, 4298 - 4303.
- [2] Álvarez P., Browning B., Jansen T., Lacroix M., Geantet C., Pitault I., Tayakout-Fayolle M. *Fuel Proc. Technol.* **2019**, *185*, 68-78.
- [3] Kim D.-W., Jeon P.R., Moon S., Lee C.-H. *En. Convers. Manage.* **2018**, *161*, 234–242.

Acknowledgements. This work was supported by the Russian Science Foundation (project No 19-79-10061).

# STEREOLITHOGRAPHY 3D PRINTED CALCIUM PYROPHOSPHATE MACROPOROUS CERAMICS FOR BONE GRAFTING

*Murashko A.M.<sup>1</sup>, Filippov Ya. Yu.<sup>1</sup>*

<sup>1</sup>Moscow State University, Moscow, Russia

Student

[amur2908@gmail.com](mailto:amur2908@gmail.com)

Calcium pyrophosphate is one of the most promising materials for the creation of bioresorbable bone implants, as it has good resorption in the body environment and shows no toxic effects [1]. When it dissolves at temperatures and pH close to physiological values, rapid precipitation of insoluble hydroxyapatite ( $\text{Ca}_{10}(\text{PO}_4)_6(\text{OH})_2$ , HA) does not occur. The fundamental problem of fabricating pyrophosphate ceramics is the low diffusivity of pyrophosphate anions, which have a large size and charge, which results in the need for high temperatures and long sintering. However, even in this case, ceramics have a low density and large grains, which is negative, mainly in terms of strength properties. This problem can be partially solved by using liquid-phase sintering with sintering additives based on various calcium phosphates, leading to the formation of low-melting eutectics [2]. For effective bone tissue regeneration, the implant must possess a system of macro- and micropores that provide diffusion of ions and promote the sprouting of the resulting bone. Currently, rapid prototyping (in particular, 3D printing) is a universal technique for forming implants with a given complex structure and shape, as traditional methods do not allow predicting and controlling the final structure of the material.

Powder precursors were prepared by ball milling of powders of hydroxyapatite ( $\text{Ca}_{10}(\text{PO}_4)_6(\text{OH})_2$ ), monocalcium phosphate monohydrate  $\text{Ca}(\text{H}_2\text{PO}_4)_2 \cdot \text{H}_2\text{O}$  and sodium dihydrophosphate  $\text{NaH}_2\text{PO}_4$  in acetone medium for 15 min with different amounts of the above phosphates, that allows to fabricate biphasic ceramics with mass ratio of calcium pyrophosphate/calcium-sodium pyrophosphate ( $\text{Ca}_2\text{P}_2\text{O}_7/\text{CaNa}_2\text{P}_2\text{O}_7$ ) 90/10, 80/20 and 70/30. For dense ceramics fabrication fresh milled powder precursors were casted into cylindrical form under the pressure of 0.5 MPa. The castings were left at room temperature over a day for drying.

Macroporous ceramics were made by stereolithographic printing from a light-cured polymer suspension and powder mixture. A powder with 10% content of mixed calcium-sodium pyrophosphate was used as a suspension filler, which was sifted through a sieve in advance to reduce the particle size. Photosensitive suspensions were made from a commercially available mixture of acrylic monomers and oligomers. A surfactant (BYK-W-985) was added to reduce the viscosity of the suspension. To investigate the depth of polymerization, the obtained suspensions were irradiated during different periods and then the thickness of the printed samples was measured. The Jacobs equation was used to approximate the dependence of polymerization depth on the irradiation dose to select the printing mode. The printed samples were further heat treated at 700°C.

According to SEM data the growth of crystallites is observed with increasing sintering temperature and increasing of sintering additive fraction in the sample. It is shown that the sintering process proceeds quite effectively even at low temperatures (600 – 700°C). According to the dilatometry data, shrinkage of the samples begins at 550°C and reaches values of 10 – 40% depending on the initial composition. It was found out that the samples of dense ceramics with 10%  $\text{CaNa}_2\text{P}_2\text{O}_7$  additive, obtained by sintering at 700°C, have the greatest strength and density. Samples of ceramics of this composition have compressive strength up to 140 MPa and density up to 98%.

Samples of macroporous material with a pore size of 900  $\mu\text{m}$  and a porosity of 65% were obtained. The compressive strength was up to  $5 \pm 1$  MPa. The Young's modulus of the obtained ceramics was  $0.48 \pm 0.06$  GPa, which is significantly lower than values for natural bone (in the range of 2 – 13 GPa), so the use of such structured materials allows solving the problem of shielding mechanical loading, which may lead to degradation of the surrounding bone tissue. The pH of the aqueous solution in contact with the fabricated pyrophosphate ceramics lies in the range 6 – 7.2, which is acceptable for biomedical applications of the material.

## References

- [1] Lee J.H., Chang B.S., Jeung U.O., Park K.W., Kim M.S., Lee C.K. *The first clinical trial of beta-calcium pyrophosphate as a novel bone graft extender in instrumented posterolateral lumbar fusion, Clinics in orthopedic surgery* 3 **2011**, 3, 238–244
- [2] Safronova T.V., Putlayev V.I., Filippov Ya.Yu., Larionov D.S., Evdokimov P.V., Averina A.E., Klimashina E.S., Ivanov V.K. *Porous ceramics based on calcium pyrophosphate, New Refractories* **2015**, 1, 46–51

# THIACALIXARENES WITH SULFUR FUNCTIONALITIES ON THE LOWER RIM: SYNTHESIS AND METAL ION COMPLEXATION IN SOLUTION AND CONFINED SPACE

*Muravev A.A.*<sup>1</sup>, *Yakupov A.T.*<sup>2</sup>, *Gerasimova T.P.*<sup>1</sup>, *Selektor S.L.*<sup>3</sup>, *Solovieva S.E.*<sup>2</sup>, *Antipin I.S.*<sup>2</sup>

<sup>1</sup>Arbuzov Institute of Organic and Physical Chemistry, FRC Kazan Scientific Center, Russian Academy of Sciences, Kazan, Russia

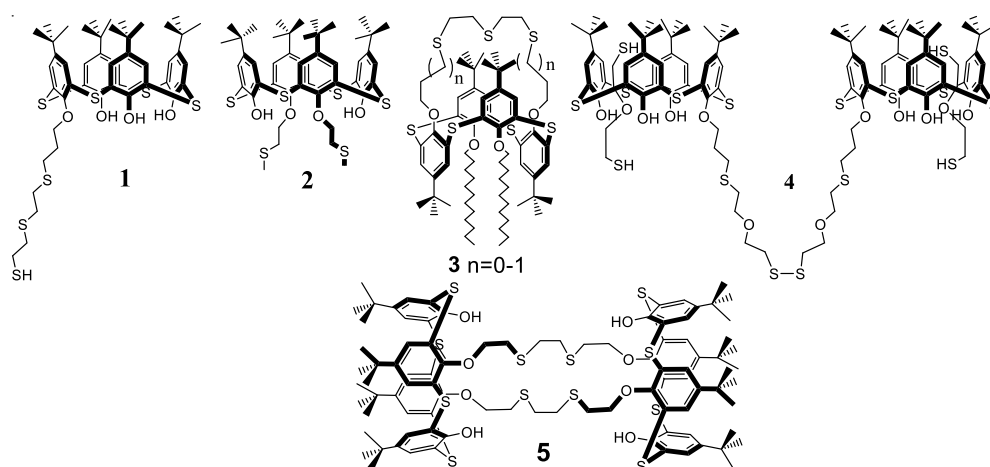
<sup>2</sup>Kazan Federal University, Kazan, Russia

<sup>3</sup>Frumkin Institute of Physical Chemistry and Electrochemistry, Russian Academy of Sciences, Moscow, Russia  
Researcher

[antonm@iopc.ru](mailto:antonm@iopc.ru)

Understanding substrate binding in 2D-confined space is crucial for the design of effective sensors and elemental basis of nanoelectronics. Of particular interest for the development of such systems are polytopic receptors preorganized on a macrocyclic scaffold. For example, thiacalixcrown-ether conjugates demonstrated different selectivity to metal ions with a transition from the gas phase to the DCM-water and air-water interfaces [1].

In this work, effect of reagent and stereoisomeric form of calixarene on direction of lower rim modification is considered, formation of podands **1,2**, thiacrown-ethers **3**, and (semi)tubes **4,5**. Mechanism of ion binding in solution and Langmuir monolayers is also discussed.



**Figure 1.** Topologies of sulfur-functionalized thiacalixarenes

## References

[1] Muravev A.A., Yakupov A.T. *Int. J. Mol. Sci.* **2021**, *22*, 3535

Acknowledgements. The work was supported by the Russian Foundation for Basic Research (project no. 20-33-70204).

# MAGNETOACTIVE METAL-POLYMER NANOMATERIALS CONTAINING COBALT (II), NICKEL (II) AND IRON: SYNTHESIS, PROPERTIES, APPLICATION

*Musatova V.Yu.<sup>1</sup>, Semenov S.A.<sup>1</sup>, Dzhardimalieva G.I.<sup>2</sup>, Smirnova O.D.<sup>3</sup>*

<sup>1</sup>MIREA – Russian Technological University (Lomonosov Institute of Fine Chemical Technologies), Moscow, Russia

<sup>2</sup>Institute of Problems of Chemical Physics of Russian Academy of Sciences, Chernogolovka, Russia

<sup>3</sup>National Research Center «Kurchatov Institute», Moscow, Russia

Postgraduate student

[VNM-arts@mail.ru](mailto:VNM-arts@mail.ru)

The aim of this work is to obtain and investigate new functional magnetic metal-polymer nanomaterials of a new generation with an increased level of consumer properties and qualities based on a number of precursors synthesized earlier by us – unsaturated dicarboxylates of cobalt (Co), nickel (Ni) and iron (Fe) - with the possibility of regulating the output physicochemical properties of nanomaterials at the stage of obtaining to improve their operational characteristics.

A feature of these magnetic metal-polymer nanocomposites containing Co, Ni and Fe, which have intrinsic magnetic moment and magnetic susceptibility, is the solution of the actual problem of simultaneous synthesis and stabilization of nanoparticles (NPs) from aggregation even at the stage of self-regulating thermolysis by means of regular distribution of NPs in the polymer matrix and formation protective polymer shell of the core-shell structure while conserving their inherent physicochemical properties at nanoscale. We have suggested and proved the possibility of predicting and, thereby, further the regulating of NPs size and the output magnetic characteristics of the obtained nanocomposites to control the predominance of the ferromagnetic nature of the nanomaterial over the superparamagnetic one, depending on the initial conditions of thermolysis. The investigated series of unsaturated dicarboxylic acids for the synthesis of precursors of Co, Ni and Fe nanocomposites: these are allylmalonic, acetylenedicarboxylic, glutaconic, itaconic, maleic, cis,cis-muconic and citraconic.

Magnetoactive metal-polymeric Co (II), Ni (II) and Fe nanocomposites, obtained by controlled thermolysis at a temperature  $335\pm 1^\circ\text{C}$  under an argon atmosphere of a number of previously synthesized and characterized by us unsaturated dicarboxylates of these metals (allylmalonates (Almal), acetylenedicarboxylates, glutaconates, itaconates (It), maleates, cis,cis-muconates, citraconates), are powders consisting of two structure elements, namely: in organic polymer matrix containing fragments  $-\text{CH}_2-$ ,  $=\text{CH}-$  и  $=\text{C}=\text{C}=\text{C}-$  the spherical NPs of  $\text{Co}_3\text{O}_4/\text{CoO}/\alpha\text{-Co}$ ,  $\text{NiO}/\beta\text{-Ni}$  or  $\gamma\text{-Fe}_2\text{O}_3$  in the polymer shell of the core-shell structure are embedded in accordance with the data of XRD and Mössbauer spectroscopy, HRTEM, EDA and elemental analysis, IR spectroscopy. It was established that the thermolysis of ItNi leads to the formation of carbon nanotubes (Fig.1).

The enthalpy ( $\Delta H^\circ_f$ ) of formation reaction of Co, Ni and Fe carboxylates by the PM3 semi-empirical quantum-chemical method with using the HyperChem 8.0.8 (Hypercube Inc.) were calculated. The average NPs diameter ( $d_{\text{adv}}$ ) of the obtained nanocomposites, namely 4-9 nm, was determined using the LabView 8.5.1 Software Product for automatic photo processing. A relationship between  $d_{\text{adv}}$  and  $\Delta H^\circ_f$  of Co, Ni and Fe carboxylates was established (Fig.2). The microstructure and magnetic characteristics of the obtained nanocomposites were determined: the highest coercive force is observed for nanocomposites based ItCo (1040 Oe), ItFe (119 Oe) and AlmalNi (131 Oe). The critical value of the NPs  $d_{\text{adv}}$  for Co associated with the transition from multi-domain to single-domain particles was found to be 3.8 nm (Fig.3).

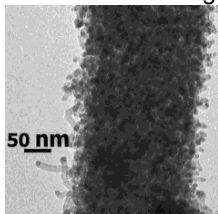


Figure 1.

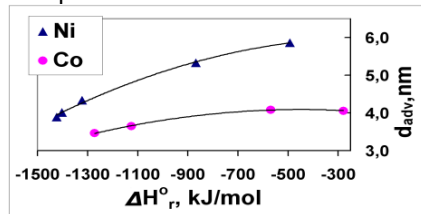


Figure 2.

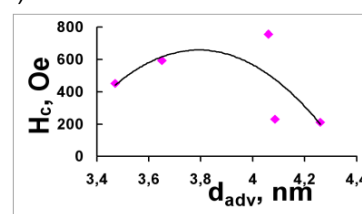


Figure 3.

The spectrum of potential fields of application of the obtained nanomaterials is extensive – from gas and magnetic sensors, catalysts, high-density magnetic storage media to new forms of drugs and medical diagnostics. The promising area of application is pharmaceuticals and medical diagnostic one, therefore, we investigated the cultivation of cell cultures of soil-forming micromycetes (*Trioderma asperellum*, *Fusarium oxysporum*, *Aspergillus niger* и *Phytophthora infectans*) and as well as human tumor cells HepG2 and HeLa on media with content of the synthesized Co, Ni and Fe nanocomposites in concentrations range  $10^{-7}$  to  $10^{-3}$  mass fraction which showed a non-monotonic dependence of the viability and cell growth properties on the dose of nanocomposites. The test intramuscular injections of magnetic Ni and Fe nanocomposites in mice line C57b in quantities of  $2 \cdot 10^{-6}$ g/g of weight didn't reveal a toxic effects.

This work was supported by the Russian Foundation for Basic Research (project No 19-03-00237).

## FEATURES OF THERMOLYSIS OF AROMATIC COMPOUNDS

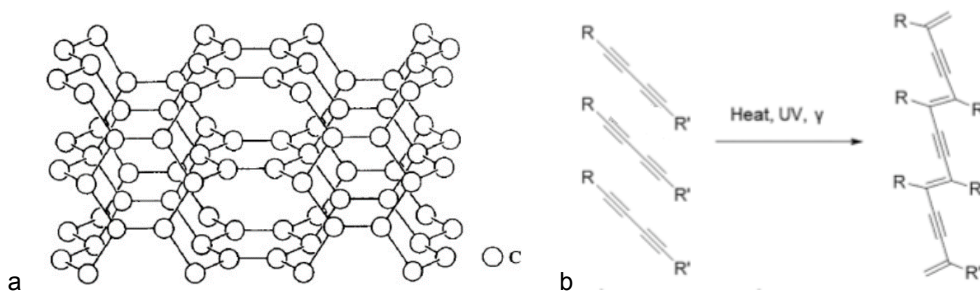
Naifert S.A.

South Ural State University (national research university), Chelyabinsk, Russia

Student

[naifert\\_sa@mail.ru](mailto:naifert_sa@mail.ru)

Carbon materials have a wide range of properties that depend on their structure. The crystalline forms of carbon are currently limited to diamond (and its hexagonal modification, Lonsdaleite), graphite, and a few fullerenes. However, in the first half of the 20th century, hypothetical structures of new carbon materials were proposed [1]. Later, the Nobel laureate in quantum chemistry Roald Hoffman proposed structures of tetragonal forms of carbon (Fig.1a), in which the carbon atoms are arranged in an orderly manner, having only sp<sup>2</sup> or alternately sp<sup>2</sup> and sp<sup>3</sup> hybridization of orbitals [2, 3]. Modern trends in chemistry aimed at organic electronics have led to the discovery of flat and linear carbon materials, crystalline polymers obtained by polymerization of diacetylene crystal monomers (Fig.1b), including graphene nanofibers obtained by thermolysis in the range of 400-600 °C of diacetylene compound crystals [5-6].



**Figure 1.** Structures of tetragonal forms of carbon (a), topochemical polymerization of diacetylenes in the solid state (b)

The studies influence of the structure of 25 aromatic compounds on the morphology of the carbon formed from them under conditions of heating in an inert atmosphere to a temperature of 970 °C. For a number of products, the specific surface area of 28-48 m<sup>2</sup> / g was determined by nitrogen adsorption. For several aromatic compounds, the formation of carbon without passing the melting stage has been demonstrated. However, X-ray phase analysis confirmed the formation of only amorphous carbon in all cases, and only in two cases-an insignificant admixture of graphite in the amorphous carbon. The thermolysis of a number of compounds was studied by the method of simultaneous thermogravimetric analysis. It is shown that slower heating during thermolysis can reduce the conversion temperature by tens of degrees and even change the nature of thermolysis.

### References

- [1] J. Gibson, M. Holohan, H.L. Riley. Amorphous Carbon. J. Chem. Soc. (1946) 456-461.
- [2] R. Hoffmann, T. Hughbanks, M. Kertesz, P.H. Bird. A Hypothetical Metallic Allotrope of Carbon. J. Am. Chem. Soc. 105. (1983) 4831-4832.
- [3] M.J. Bucknum, R. Hoffmann. A Hypothetical Dense 3,4-Connected Carbon Net and Related B<sub>2</sub>C and CN<sub>2</sub> Nets Built from 1,4-Cyclohexadienoid Units. J. Am. Chem. Soc. 116. (1994) 11456-11464.
- [4] E.A. Belenkov, V.A. Greshnyakov. Diamond-Like Phases Obtained from Nanotubes and Three-Dimensional Graphites. Physics of the Solid State. 57(6). (2015) 1253-1263.
- [5] Q.Y. Li, Y.F. Yao, G. Qiu, P. Zhang, H.L. Dong, W.P. Hu. Topochemical polymerization of diacetylenes. Chinese Science Bulletin. 61(24). (2016) 2688-2706.
- [6] R.S. Jordan, Y.L. Li, C.-W. Lin, R.D. McCurdy, J.B. Lin, J.L. Brosmer, K.L. Marsh, S.I. Khan, K.N. Houk, R.B. Kaner, Y. Rubin. Synthesis of N = 8 Armchair Graphene Nanoribbons from Four Distinct Polydiacetylenes. J. Am. Chem. Soc. 139. (2017) 15878-15890.

Acknowledgements. This work was supported by Russian Foundation for Basic Research (project No 20-33-90094).

## 3D PRINTING OF OPTICALLY ACTIVE MATERIALS BASED ON CARBON DOTS AND CELLULOSE NANOCRYSTALS

*Navrotskaya A.G.<sup>1</sup>, Aleksandrova D.D.<sup>1</sup>, Chekini M.<sup>2</sup>, Yakavets I.<sup>2</sup>, Kheiri S.<sup>2</sup>, Krivoschapkina E.F.<sup>1</sup>, Kumacheva E.<sup>1,2</sup>*

<sup>1</sup>ITMO University, Saint Petersburg, Russian Federation

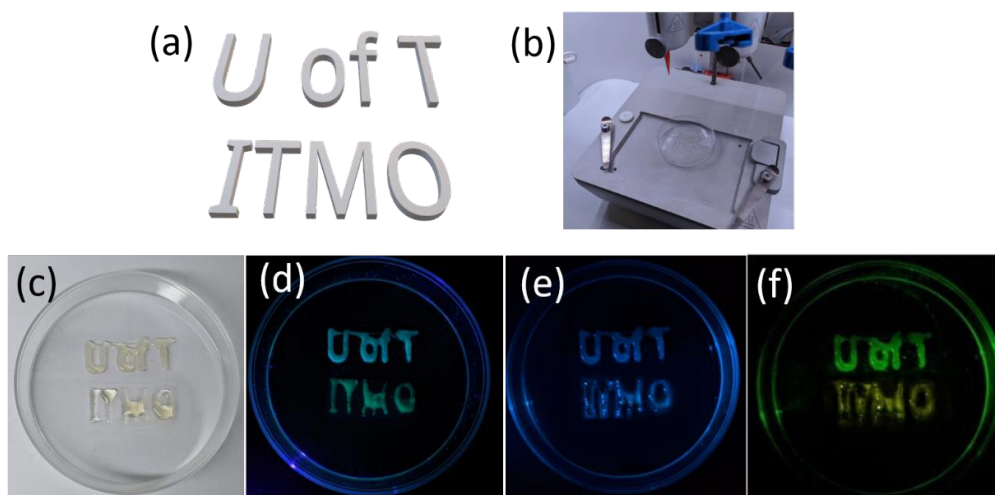
<sup>2</sup>University of Toronto, Toronto, Canada

PhD Student

[navrotskaya@scamt-itmo.ru](mailto:navrotskaya@scamt-itmo.ru)

Carbon dots are quasi-spherical zero-dimensional carbon nanomaterials with the diameter less than 10 nm [1]. Due to their excellent water solubility, chemical inertness, low toxicity, ease of functionalization and resistance to photobleaching, carbon dots are gradually becoming a new star in the carbon nanomaterial family [2]. Their optical properties, in particular, excitation and solvent dependent fluorescence, allows the use of carbon dots as optical sensors or for 3D security printing.

Three-dimensional (3D) printing is a digitally controlled layering technology for the production of geometrically complex components. The development of liquid precursors for 3D printed materials (also called "inks") has emerged as a separate, actively explored field with almost limitless possibilities. However, at the moment, there are practically no reproducible and stable methods of producing specialized inks for 3D printing materials with specific functions and applications, and the growing requirements for a wide variety of related materials, their sizes and their architectures are not being met [3]. The proposed research project aims to develop a colloidal ink for 3D security printing based on carbon dots and cellulose nanocrystals. These ionic crosslinked inks exhibit excitation and solvent polarity dependent fluorescence. Figure 1 shows 3D printed objects under various light sources (c-f), prepared in solvents with different polarity, in water ("U of T") and DMSO ("ITMO").



**Figure 1.** (a) 3D model from Tinkercad program. (b) Images of the printing process. (b) Images of the printed structure based on C-dot/CNC gels in water (top) and in DMSO (bottom) under (c) white light, (d) UV light illumination  $\lambda_{ex} = 395$  nm, (e) blue light  $\lambda_{ex} = 470$  nm, (f) green light illumination  $\lambda_{ex} = 530$  nm.

### References

- [1] Muthamma K., et al. *Applied Materials Today* **2021**, 23, 101050
- [2] Anwar S., et al. *ACS Applied Bio Materials* **2019**, 2(6), 2317-2338
- [3] Li J., et al. *Materials Science and Engineering: R: Reports*. **2020**, 140, 100543

Acknowledgements. This work is supported by the Ministry of Science and Higher Education of Russia (project No. 075-15-2019-1896).



# MODIFICATION OF THE TITANIUM AND NITINOL SURFACE BY LIQUID-PHASE CHEMICAL ETCHING AND ATOMIC LAYER DEPOSITION OF TITANIA LAYERS AND SILVER NANOPARTICLES

Nazarov D.V.<sup>1,2</sup>, Mitrofanov I.V.<sup>2</sup>, Ezhov I.S.<sup>2</sup>, Maximov M.Yu.<sup>2</sup>, Popovich A.A.<sup>2</sup>

<sup>1</sup>Saint Petersburg State University, Saint Petersburg, Russia

<sup>2</sup> Peter the Great Saint Petersburg Polytechnic University, Saint Petersburg, Russia

Young Scientist

[dennazar1@yandex.ru](mailto:dennazar1@yandex.ru)

Titanium and its alloys are the most suitable and widely used materials for producing orthopedic and dental implants [1-3]. The success of using these materials is caused by the combination of unique mechanical properties and excellent biocompatibility [1,3]. The alloys have much more suitable mechanical properties for medical application than pure titanium [2]. But they are potentially more dangerous due to the possible release of allergic, carcinogenic, and toxic elements such as nickel, vanadium, niobium, etc. To improve the biocompatibility and bioactivity of titanium-based materials the many methods for surface modification are used. Among them, some of the most promising are liquid-phase chemical etching (CE) and atomic layer deposition (ALD). CE is very successful to produce the developed relief and morphology of the surface which can significantly accelerate and improve implant osseointegration. ALD is the method for coating the material with very thin uniform and conformal nanofilms. ALD is based on the cyclic self-limiting gas-solid chemical reactions on the support surface whereby the coating is grown layer by layer. While an increasing the number of chemical reactions (number of ALD cycles), the coating thickness increases as well.

In this work, the bulk and 3d-frame structures of titanium and nitinol were produce using selective laser melting (SLM). The liquid-phase chemical etching of pure titanium and nitinol was studied using the standard etchant (H<sub>2</sub>SO<sub>4</sub>/HCl) and piranha solutions (H<sub>2</sub>SO<sub>4</sub>/H<sub>2</sub>O<sub>2</sub> and NH<sub>4</sub>OH/H<sub>2</sub>O<sub>2</sub>) which less common for medical pretreatment. It was found that piranha solutions are more active etchants in comparison to standard H<sub>2</sub>SO<sub>4</sub>/HCl mixture for both titanium and nitinol. Moreover, the results showed that NH<sub>4</sub>OH/H<sub>2</sub>O<sub>2</sub> etching during 30-120 min produces hierarchical micro-nanoscale structures which are very promising for the improvement osseointegration of titanium-based implants. Also, it was found that NH<sub>4</sub>OH/H<sub>2</sub>O<sub>2</sub> etching not cause surface oxidation and decrease (dissolute) the native titania surface layer. Therefore the additional surface coating which can prevent Ni and Ti ions dissolution is necessary. After that, a technique was developed for the deposition of a polycrystalline nanolayer of titanium oxide with an anatase structure by the ALD at temperatures no higher than 300C. TiCl<sub>4</sub> and H<sub>2</sub>O were used as precursors. 400 ALD cycles were applied and thickness of layers was approximately 40 nm. The scanning electron microscopy (SEM) showed that developed technique of coating allowed maintaining the surface relief obtained by CE.

To induce the antibacterial properties of the surface the Ag nanoparticles were ALD deposited on the CE and TiO<sub>2</sub> coated samples. The triethylphosphine- (6,6,7,7,8,8,8-heptafluoro-2,2-dimethyl-3,5-octanedionate)silver(I) [Ag(fod)-(PEt<sub>3</sub>) - C<sub>16</sub>H<sub>25</sub>AgF<sub>7</sub>O<sub>2</sub>P] and hydrogen plasma were used as precursors. The SEM and x-ray photoelectron spectroscopy confirmed the formation of separate nanoparticles of about 20 nm but not a continuous layer of Ag. The obtained samples showed high antibacterial activity using gram-positive and gram-negative bacteria.

Finally the in vitro adhesion, viability, proliferation and differentiation of human preosteoblast MG-63 cells were assessed. The results showed that samples are not cytotoxic and surface modification remarkably improves proliferation and differentiation of MG-63 cells in osteogenic direction.

## References

- [1] Brunette, D.M.; Tengvall, P.; Textor M.; Thomsen P. Titanium in Medicine; Springer: Berlin/Heidelberg, Germany; **2001**; pp. 1–1019.
- [2] Li Y.; Yang C.; Zhao H.; Qu S.; Li X.; Li Y. *Materials* **2014**, *7*, 1709-1800.
- [3] Nazarov D.V.; Smirnov V.M.; Zemtsova E.G.; Yuditceva N.M.; Shevtsov M.A.; Valiev R.Z. *ACS Biomater Sci Eng* **2018**, *4*, 3268-3281.

Acknowledgements. This research was conducted under the financial support the Russian Science Foundation grant (project No. 20-73-00067). The research was conducted using the equipment of the resource centers of the Research Park of the St. Petersburg State University "Innovative Technologies of Composite Nanomaterials", "Center for Physical Methods of Surface Investigation", «X-ray Diffraction Studies» and "Nanotechnology Interdisciplinary Center".

# PREPARATION OF FUNCTIONALIZED AMPHIPHILIC COPOLYMERS OF POLY-N-VINYLPYRROLIDONE AND ACRYLIC ACID FOR DRUG DELIVERY SYSTEMS

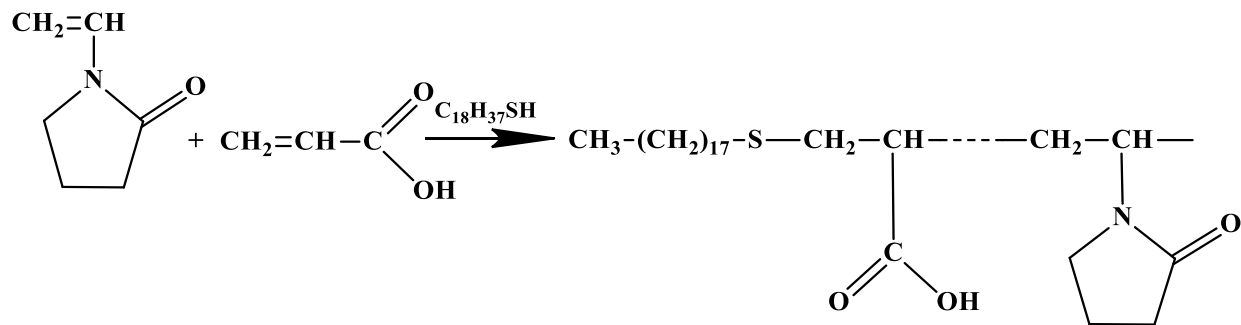
*Nechaeva A.M., Zhukova A.A., Maslak M.A., Shashkova T.M., Luss A.L., Kuskov A.N.*

Mendeleev University of Chemical Technology of Russia, Moscow, Russia  
PhD student  
nechaeva@muctr.ru

Polymeric micelles have received increased attention due to their ability to load active substances and to attach visualizing agents and target molecules, ensure their accurate delivery to the site of action as well as improve the pharmacokinetic of the loaded drug and reduce off-target cytotoxicity. Due to the high biocompatibility and low toxicity, amphiphilic copolymers of N-vinylpyrrolidone have proven to be reliable materials for the development of targeted drug delivery systems [1-2]. Copolymers comprised of the one hydrophilic and one hydrophobic part, that provides easy self-organization of macromolecules into micelles in aqueous media, which was used in the further synthesis of nanoscale drug carriers.

The aim of this work is to obtain functionalized amphiphilic polymers of various molecular weights as a subsequent nanobase for theranostics and to study their characteristics depending on the change in the percentage of reagents.

In this work, copolymers of N-vinylpyrrolidone and acrylic acid with different monomers ratio were obtained. Molecular weight of copolymers was controlled by adding of different amounts of chain transfer agent - octadecyl mercaptan ( $C_{18}H_{37}SH$ ). The reaction proceeds according to the mechanism of radical polymerization in a dioxane solution for 3 hours at a temperature of  $70^{\circ}C$  in the presence of dinitrile azobisisobutyric acid as an initiator. The synthesized polymers were purified by rotary distillation of the solvent, dialysis against water and freeze-dried.



**Figure 1.** Formation of amphiphilic copolymer.

The resulting polymer molecules contained hydrophilic fragment and only one terminal hydrophobic group attached by a covalent bond. The molecular weight was in the range of 3,5 to 13 kDa.

The structure of obtained copolymers was studied by  $^{13}C$  NMR spectroscopy. The critical concentration of micelle formation (CMC) was investigated using conductometric method. The hollow micellar nanoparticles were obtained by ultrasound treatment of an aqueous polymer solution and freeze-dried. Their size and charge were measured by laser diffraction method.

The proposed approach allows to obtain amphiphilic copolymers of different molecular weights. Copolymers can be used as the basis for the delivery systems of various drugs, the production of radiolabeled and targeted nanoparticles intended for the diagnosis and therapy of tumor diseases. The resulting micelles can be functionalized with gadolinium as a contrast agent for MRI. Due to the presence of free carboxylic acid groups, covalent attachment to the polymer of fragments targeting cancer cells (FALGEA peptide) can be achieved to obtain selective drug delivery.

## References

- [1] Luss A.L., Kulikov P.P., Romme S.B., Andersen C.L., Pennisi C.P., Docea A.O., Kuskov A.N., Velonia K., Mezhev Ya.O., Shtilman M.I., Tsatsakis A.M., Gurevich L. Nanosized carriers based on amphiphilic poly-N-vinyl-2-pyrrolidone for intranuclear drug delivery. *Nanomedicine*, **2018**, *13*, 703–715
- [2] Tsatsakis A., Stratidakis A.K., Goryachaya A.V., Tzatzarakis M.N., Stivaktakis P.D., Docea A.O., Berdiaki A., Nikitovic D., Velonia K., Shtilman M.I., Rizos A.K., Kuskov A.N. In vitro blood compatibility and in vitro cytotoxicity of amphiphilic poly-N-vinylpyrrolidone nanoparticles. *Food Chem Toxicol.* **2019**, *127*, 42–52

# ADVANCED APPROACHES BASED ON SOL-GEL AND SUPERCRITICAL FLUID METHODS FOR THE SYNTHESIS OF HETEROGENEOUS CATALYSTS

*Nesterov N.S.<sup>1</sup>, Filippov A.A.<sup>1</sup>, Martyanov O.N.<sup>1</sup>*

*<sup>1</sup> Boreskov Institute of Catalysis,<sup>2</sup> Novosibirsk State University  
Young Scientist  
nesterov@catalysis.ru*

The development of advanced methods for the synthesis of efficient catalysts is an actual task for chemical industry. The required structure and optimal morphology of the catalysts allow scientists to control the product composition and mitigate reaction conditions, which can increase the efficiency and ecological compatibility of the process. However, the conventional methods of the catalysts synthesis itself often lead to the formation of a large amount of waste.

One of the alternative methods to overcome the abovementioned difficulties is the development of green chemistry methods [1]. It's well-known that the supercritical CO<sub>2</sub> is an environmentally friendly media for various processes due to its availability, non-toxicity, ease of recycling, and low critical parameters (T<sub>c</sub>=303.9 K, P<sub>c</sub>=7,38 MPa). So, the precipitation in Supercritical CO<sub>2</sub> as AntiSolvent (SAS) is a promising catalyst synthesis approach [2–4]. The fast diffusion of supercritical CO<sub>2</sub> leads to a high supersaturation and, as a result, to precipitation of well-mixed metal systems, which can demonstrate high catalytic activity [5].

In this work we propose methods for the synthesis of heterogeneous catalysts based on coprecipitation of different sols (SiO<sub>2</sub>, Al<sub>2</sub>O<sub>3</sub>, ZrO<sub>2</sub> and TiO<sub>2</sub>) and active phase precursors in supercritical CO<sub>2</sub>. This method allows us to synthesize metal-oxide systems containing highly dispersed metal particles. The oxide matrix prevents the sintering of metal particles, increases the dispersion and specific surface area, as well as accessibility of active phase.

## References

- [1] Hutchings G.J. *Top. Catal.* **2009**, 52 982–987.
- [2] Nesterov N.S., Shalygin A.S., Pakharukova V.P., Glazneva T.S., Martyanov O.N. *J. Supercrit. Fluids.* **2019**, 149, 110–119.
- [3] Nesterov N.S., Shalygin A.S., Glazneva T.S., Pakharukova V.P., Martyanov O.N. *Gold Bull.* **2021**, 54, 69–74.
- [4] Alekseev E.S., Alentiev A.Y., Belova A.S., Bogdan V.I., Bogdan T.V., Bystrova A.V., Gafarova E.R., Golubeva E.N., Grebenik E.A., Gromov O.I., Davankov V.A., Zlotin S.G., Kiselev M.G., Koklin A.E., Kononevich Y.N., Lazhko A.E., Lunin V.V., Lyubimov S.E., Martyanov O.N., Mishanin I.I., Muzafarov A.M., Nesterov N.S., Nikolaev A.Y., Oparin R.D., Parenago O.O., Parenago O.P., Pokusaeva Y.A., Ronova I.A., Solovieva A.B., Temnikov M.N., Timashev P.S., Turova O.V., Filatova E.V., Philippov A.A., Chibiryayev A.M., Shalygin A.S. *Russ. Chem. Rev.* **2020**, 89, 1337–1427.
- [5] Nesterov N.S., Smirnov A.A., Pakharukova V.P., Yakovlev V.A., Martyanov O.N. *Catal. Today.* **2020**, in press, <https://doi.org/10.1016/j.cattod.2020.09.006>.

Acknowledgements. This work was supported by Russian Science Foundation (Project № 21-13-00065, <https://rscf.ru/en/project/21-13-00065/>)

*Nikiforova K.V.<sup>1</sup>, Kurapova O.Yu.<sup>1,2</sup>, Konakov V.G.<sup>2</sup>*

<sup>1</sup>Saint Petersburg State University, Saint Petersburg, Russia

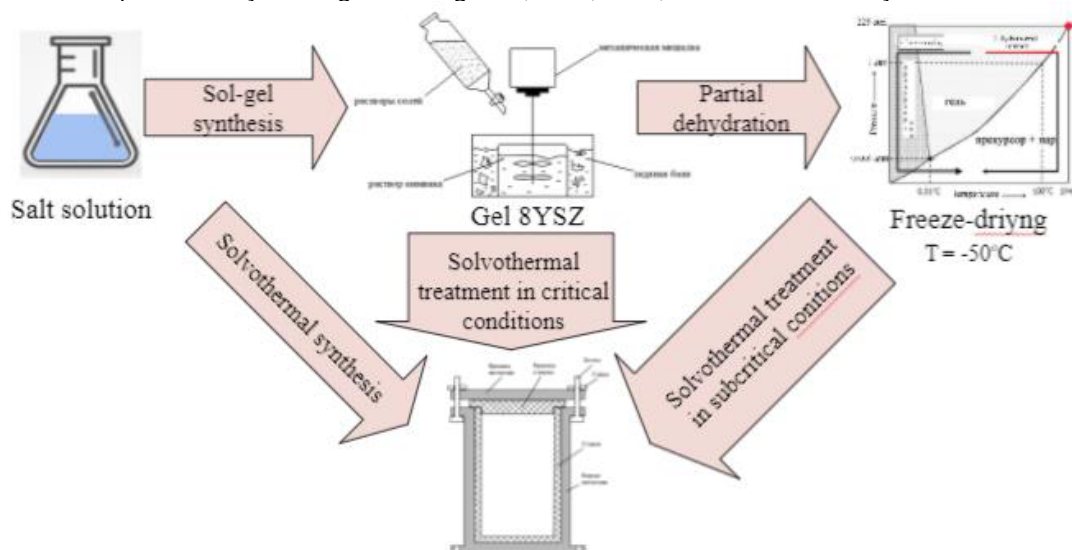
<sup>2</sup>Glass and Ceramics LTD, Saint Petersburg, Russia

Student

[Kristaliya98@mail.ru](mailto:Kristaliya98@mail.ru)

It is well-known, that the correct choice of synthesis technique predetermines the final properties of zirconia based solid electrolytes. The solvothermal synthesis is one of the most promising methods due to its simplicity, as well as the possibility of crystallization of solid solutions at relatively low temperatures. This method has a number of advantages over other thermal methods: it makes it possible to obtain particles of the required size, control the stoichiometry of the resulting solid solutions, as well as their morphology. The present research is devoted to the effect of hydro- and solvothermal synthesis conditions on the physical and chemical properties of zirconia based precursors.

Gels of stabilized zirconia were obtained by sol-gel synthesis method in the reverse co-precipitation variance and synthesis conditions were  $T = 1-2^{\circ}\text{C}$ ,  $\text{pH} = 9-10$ . Then, the initial aqueous and water-organic solutions, freshly prepared gel and freeze-dried amorphous powders were subjected to solvothermal synthesis at different temperatures from 180 to  $280^{\circ}\text{C}$  and, further, dried to constant weight at  $110^{\circ}\text{C}$  (Fig.1). Precursors obtained were comprehensively investigated using STA, XRD, SEM, PSD and BET analysis.



**Figure 1.** Scheme of synthesis.

It was shown that the solvothermal synthesis from aqueous-alcoholic and aqueous-acetone solutions leads to the crystallization of zirconia cubic solid solution at  $260^{\circ}\text{C}$ , while the hydrothermal synthesis from an aqueous solution leads to the formation of monoclinic  $\text{ZrO}_2$ .

Precursors obtained from freshly prepared gel were found to be cubic phase. The beginning of crystallization in critical conditions is observed after hydrothermal treatment at  $200^{\circ}\text{C}$ . Precursors from freeze-dried amorphous powders received in subcritical conditions up to  $280^{\circ}\text{C}$  remain amorphous.

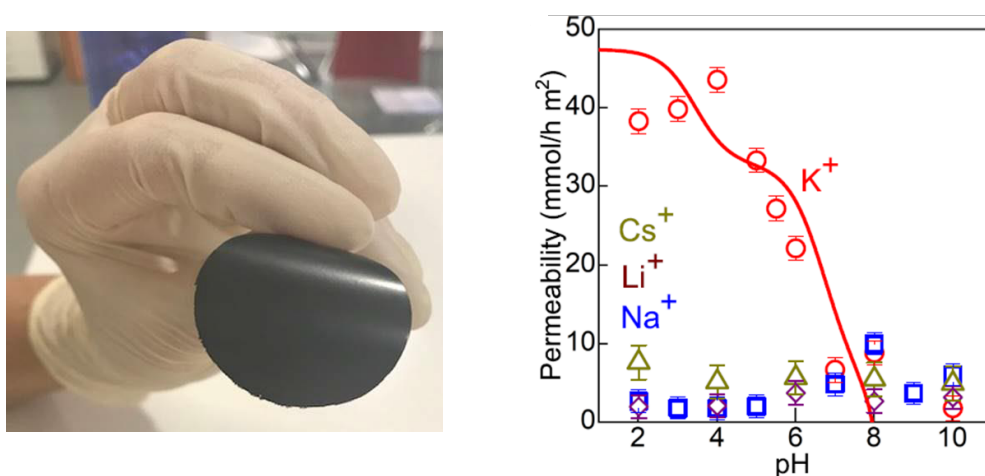
**Acknowledgements.** DSC and TG studies were performed at the Thermogravimetric and Calorimetric Research Centre; Adsorption-desorption studies were performed in the Center for Innovative Technologies of Composite Nanomaterials and SEM studies were performed at the Interdisciplinary Resource Centre for Nanotechnology at the research park of SPBU.

*Nikitina A.A.<sup>1</sup>, Andreeva D.V.<sup>2</sup>*

<sup>1</sup>ITMO University, Saint Petersburg, Russia  
<sup>2</sup>National University of Singapore, Singapore  
 Ph.D. student  
[nikitina@itmo.ru](mailto:nikitina@itmo.ru)

The cell membrane is important to the interface, which many scientific groups would like to create artificially. Such membranes can regulate the ionic flow based on the signal exchange between cells and the environment. The physical and chemical properties of membrane materials similarity with cell membranes with defined functions are in high demand.

In the current project, the 2D-based adaptive membrane with the controlling properties was investigated. Here we suggested a new composite based on graphene oxide and polyamine macromolecules. The novelty of such membranes is the selectivity penetrating of potassium cations comparing with other alkali ions. Moreover, the presence of  $K^+$  provides a permittivity for cesium ions, which similar to “ionic transistor” behavior.



**Figure 1.** A photograph of free-standing GO-PA membrane. Ionic permeation of GO-PA membranes as a function of pH measured separately for  $K^+$  and  $Na^+$ .

Water and ions flow can be predetermined on the synthesis step, their protonation state can control by the external pH or presence of ions. Finally, the challenges and outlook on using 2D-based membrane nanostructure for cell membrane engineering presents are promising for further investigation.

#### References

- [1] Chen, L. et al. Ion sieving in graphene oxide membranes via cationic control of interlayer spacing. *Nature* 550, 415-418, doi:10.1038/nature24044 (2017)
- [2] Gopinadhan, K. et al. Complete steric exclusion of ions and proton transport through confined monolayer water. *Science* 363, 145-148, doi:10.1126/science.aau6771 (2019)
- [3] Hong, S. et al. Scalable graphene-based membranes for ionic sieving with ultrahigh charge selectivity. *Nano Lett.* 17, 728-732, doi:10.1021/acs.nanolett.6b03837 (2017).

Acknowledgments. This work was supported by the Russian Science Foundation (project No 19-19-00508)

# STRUCTURE, OPTICAL ABSORBANCE AND ELECTRICAL CONDUCTIVITY OF PEROVSKITE THIN FILMS DOPED WITH QUATERNARY AMMONIUM IODIDES

*Nikitin I.A.*<sup>1</sup>, *Koptyaev A.I.*<sup>1</sup>, *Fedoseev A.N.*<sup>2</sup>, *Travkin V.V.*<sup>2</sup>

<sup>1</sup> Ivanovo State University of Chemistry and Technology, Ivanovo, Russia

<sup>2</sup> Institute for Physics of Microstructures RAS, Nizhny Novgorod, Russia

Student

[ivan.nikitin-15@yandex.ru](mailto:ivan.nikitin-15@yandex.ru)

Conventional hybrid perovskite-like materials such as methylammonium (MAPI) or formamidinium (FAPbI<sub>3</sub>) lead iodides are interesting for photovoltaics due to their large absorption coefficient, tunable bandgap, high charge carrier mobility and diffusion length, long intrinsic carrier recombination lifetime and low-cost fabrication methods [1]. The power conversion efficiency of perovskite-based solar cells rises up from 3.9 to 25.2 % in last decade [2]. However, the commercialization is still complicated by certain important issues like the phase/chemical degradation of perovskite under light/temperature and in wet atmosphere (hydrolysis) [3]. The soft doping of neat hybrid perovskite with quaternary ammonium (QA) salts [4] is the one of the approaches to improve its phase stability through the passivation of the ionic defects that arise from acidic hydrogen atoms.

In this study, three different QA compounds were added to MAPI at a rate of a few percent: tetramethylammonium iodide (TMAI), tetraethylammonium iodide (TEAI) and tetrabutylammonium iodide (TBAI). Two laboratory techniques – thermal evaporation and spin-coating – were used to fabricate thin perovskite films on the glass/FTO and silicon substrates. The first deposition technique is based on the combined co/sequential regime under the pressure of 0.0007 Pa. In the second deposition technique, the QA were added to the solutions of the perovskite precursors in DMSO/DMF with the molar concentrations ranging from 0 to 0.01. The top metal electrodes and functional auxiliary layers were deposited using vacuum method, if necessary.

The structure, surface morphology, optical and electrical properties of thus doped perovskite thin-films were studied using grazed-incidence x-ray diffraction, white-light interferometry, optical spectroscopy and DC current measurements both in the dark and when illuminated with simulated sunlight.

The results are discussed with focus on the importance of deposition regime and dopant concentration.

## References

- [1] *Inorg. Chem.* **2013**, 52, 9019-9038.
- [2] *Nature* **2021**, 592, 381-385.
- [3] *Sci.Rep.* **2016**, 6, 21976.
- [4] *Nat. Energy*, **2017**, 2, 17102.

Acknowledgements. This work was supported by the Russian Foundation for Basic Research (project No 20-38-70123).

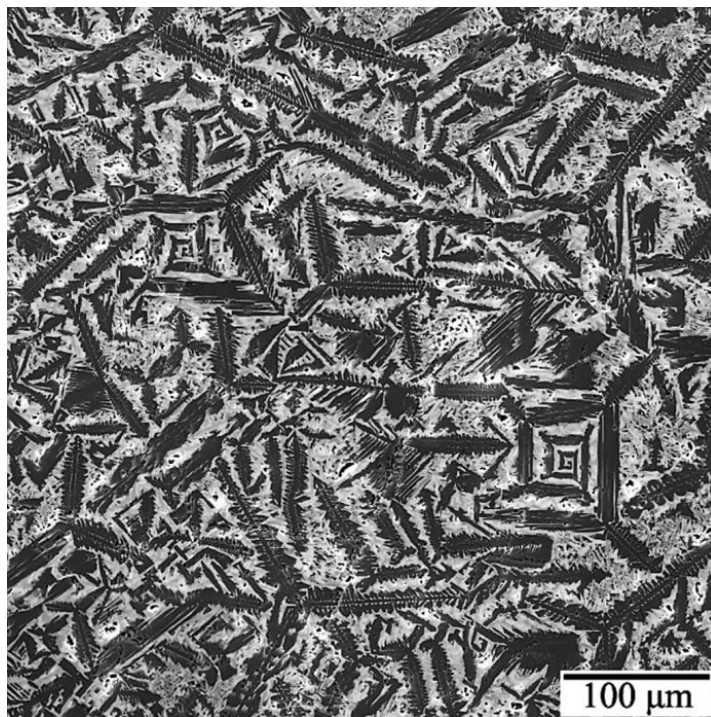
## CRYSTALLIZED TERNARY EUTECTICS IN THE $\text{LaB}_6\text{-W}_2\text{B}_5\text{-NbB}_2$ SYSTEM

*Novoselov E.S<sup>1</sup>., Nesmelov D.D<sup>1</sup>., Danilovich D.P<sup>1</sup>.*

<sup>1</sup>Saint-Petersburg state institute of technology  
[lehmann330@gmail.com](mailto:lehmann330@gmail.com)

$\text{LaB}_6$  is one of the most widely used hexaborides. Due to its low work function of electrons and high emission current density, it is widely used as thermionic cathodes for Hall thrusters and microcathodes for scanning electron microscopes [1-3].

Development of materials based on  $\text{LaB}_6$  is related to the study of eutectic systems with the number of components  $n = 3$  [3]. In this work ternary alloys in the  $\text{LaB}_6 - \text{W}_2\text{B}_5 - \text{NbB}_2$  system were obtained by melting in an electric arc discharge. Eutectic structures of the lamellar and rod types were investigated using scanning electron microscopy, XRD and EDS analysis. It was found that crystallized objects contained lanthanum hexaboride,  $\alpha$ -solid solution  $(\text{W}_x\text{Nb}_{1-x})_2\text{B}_5$ , and  $\beta$ -solid solution  $(\text{Nb}_x\text{W}_{1-x})\text{B}_2$ . An assumption was made about the existence of a ternary phase in the Nb-W-B system, which is close to the composition  $\text{Nb}_{0.5}\text{W}_{0.5}\text{B}_4$



**Figure 1.** – SEM-image of crystallized sample at system  $\text{LaB}_6\text{-NbB}_2\text{-W}_2\text{B}_5$

### References

- [1] Cahill, J. T., & Graeve, O. A. *J. Mater. Sci. Technol.* **2019.**, 8(6), 6321-6335.
- [2] Back, Tyson C., et al. *Ultramicroscopy* **2017** 183, 67-71.
- [3] Ordanyan, S. S., Vikhman, S. V., Nesmelov, D. D., Danilovich, D. P., & Panteleev, I. B. *In Advances in Science and Technology* **2014.**, 89, 47-56.

Acknowledgements. This work was supported by the Russian Science Foundation (project No 19-73-10180)

# SIZE-SELECTIVE AEROBIC-ANAEROBIC SWITCHING OF PHOTOCATALYTIC PATHWAYS IN PORPHYRIN-BASED SURMOF/GRAPHENE OXIDE MATERIALS

*Nugmanova A.G.*<sup>1</sup>, *Safonova E.A.*<sup>1</sup>, *Baranchikov A.E.*<sup>2</sup>, *Shkolin A.V.*<sup>1</sup>, *Mitrofanov A.A.*<sup>3</sup>,  
*Eliseev A.A.*<sup>3</sup>, *Meshkov I.N.*<sup>1</sup>, *Kalinina M.A.*<sup>1</sup>

<sup>1</sup> A. N. Frumkin Institute of Physical Chemistry and Electrochemistry, Russian Academy of Sciences, Moscow, Russia

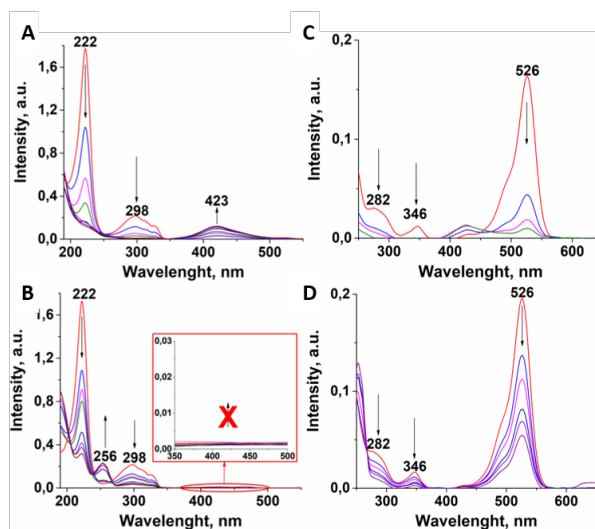
<sup>2</sup> N. S. Kurnakov Institute of General and Inorganic Chemistry, Russian Academy of Sciences, Moscow, Russia

<sup>3</sup> Moscow State University, Moscow, Russia

PhD student

[nugmanovaalsy@gmail.com](mailto:nugmanovaalsy@gmail.com)

In this work, we report on a new method to synthesize new sponge-like photocatalytic materials comprising graphene oxide (GO) and zinc porphyrin complexes ordered into surface-attached metal organic frameworks (SURMOFs). To obtain the SURMOF/GO hybrids in a powdered form, we developed a one-pot synthesis of these materials in the GO-stabilized oil-in-water Pickering emulsions. The oxidized groups on the GO sheets promote the adsorption of metal clusters followed by anchoring of porphyrins to the surface of 2D carbon [1]. The results of experimental studies involving X-ray diffraction, UV-vis spectroscopy, BET nitrogen absorption, gas chromatography-mass-spectrometry and MALDI-TOF spectroscopy. The data suggest that these mesoporous SURMOF/GO hybrids can exploit two different mechanisms yielding different products of photocatalytic degradation of model organic compounds such as rhodamine 6G (Rh6G) and 1,5-dihydroxynaphtalene (DHN). The oxidation through photoinduced generation of singlet oxygen on porphyrin centers occurs in the presence of oxygen [2]. In anaerobic conditions, the catalysts can promote reduction by a direct electron transfer to the substrates in the SURMOF pores. Their size controls the efficiency of the anaerobic process. The SURMOF/GO with the pore size of 1.6 nm can transform both Rh6G and DHN (fig. 1), whereas the material with 1.1-nm pores is active only with respect to the small DHN molecules. The results provide a rational basis for the substrate-selective GO-based hybrid photocatalytic materials integrated with SURMOF components with tunable porosity.



**Figure 1.** UV-vis spectra for DHN (a,b) and Rh6G (c,d) in presence SURMOF/GO with the pore size of 1.6 nm at aerobic (a,c) and anaerobic (b,d) conditions.

## References

- [1] Meshkov I.N., Zvyagina A.I., Shiryaev A.A., Nickolsky M.S., Baranchikov A.E., Ezhov A.A., Nugmanova A.G., Enakieva Y.Y., Gorbunova Y.G., Arslanov V.V., Kalinina M.A. *Langmuir*. **2018**, *34*, 5184–5192  
[2] Meshkov I.N., Bulach V., Gorbunova Y.G., Gostev F.E., Nadochenko V.A., Tsivadze A.Y., Hosseini M.W. *Chem. Commun.* **2017**, *53*, 9918–9921

Acknowledgements. This work was supported by the Russian Science Foundation (project No 20-13-00279) and Russian Foundation for Basic Research (project No 18-29-04026\_mk).

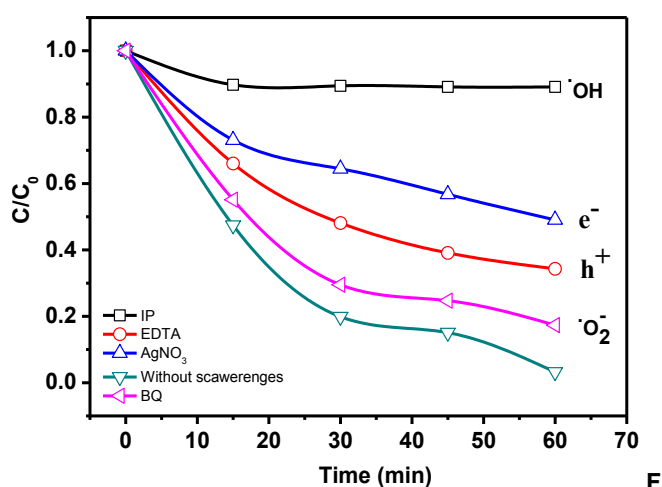


# MECHANISM OF PIEZOPHOTOCATALYTIC METHYLENE BLUE DECOMPOSITION BY $\alpha\text{-Fe}_2\text{O}_3\text{@PVDF}$ NANOFIBERS FILM

Orudzhev F.F.<sup>1</sup>, Selimov D.A.<sup>1</sup>, Gulakhmedov R.R.<sup>1</sup>, Kadiev M.V.<sup>1</sup>, Shuaibov A.O.<sup>1</sup>, Abdurakhmanov M.G.<sup>1</sup>, Ramazanov Sh.M.<sup>1</sup>, Sobola D.S.<sup>1</sup>

<sup>1</sup>Dagestan State University, Makhachkala, Russia  
Student  
[ff.orudzhev@dgu.ru](mailto:ff.orudzhev@dgu.ru)

The use of the piezoelectrochemical effect in photocatalysis is a new tool that provides a more efficient separation of photoinduced charges due to the generation of an internal electric field under the action of mechanical stress. Although there are many reports of using this effect to decompose organic compounds, very little attention has been paid to the mechanism of the decomposition process. In this study, we synthesized a composite organic-inorganic material combining the piezoelectric properties of polyvinylidene fluoride (PVDF) and the photocatalytic properties of iron oxide ( $\alpha\text{-Fe}_2\text{O}_3$ ) and used it for the piezophotocatalytic decomposition of Methylene Blue (MB).



**Figure 1.** Piezophotocatalytic performance of  $\alpha\text{-Fe}_2\text{O}_3$  containing PVDF nanofibers for degradation of MB under UV-Vis light after adding various scavengers.

The samples were synthesized according to the protocol described in our previous work [2].

To elucidate the mechanism of piezocatalysis and piezophotocatalysis under UV-Vis irradiation, experiments were carried out to capture active particles generated in the system. The data are presented in Figure 1. Isopropanol (IPA), p-Benzoquinone (BQ), triethanolamine (EDTA) and silver nitrate ( $\text{AgNO}_3$ ) were used as scavengers for hydroxyl radicals ( $\cdot\text{OH}$ ), superoxide radicals ( $\cdot\text{O}_2^-$ ), holes ( $\text{h}^+$ ) and electrons ( $\text{e}^-$ ), respectively. For piezophotocatalysis, the addition of all types of absorbers leads to a drop in activity. The addition of IPA as a  $\cdot\text{OH}$  scavenger led to a significant decrease in the decomposition efficiency to 11%, which suggests that MB decomposition predominantly proceeds through the  $\cdot\text{OH}$  particles. The decrease in the degree of decomposition of the MS upon the addition of EDTA and  $\text{AgNO}_3$  to 61.5 and 51.1%,

respectively, also indicates the importance of electrons and holes in the process. The addition of BQ caused a slight decrease in the decomposition efficiency (up to 83.1%), indicating an insignificant contribution of superoxide radicals ( $\cdot\text{O}_2^-$ ) to the decomposition of MS.

Using photoluminescence with selective radical markers, the role of hydroxyl radicals in the process of MB decomposition is shown. The decay products were identified using gas chromatography-mass spectrometry.

## References

- [1] Tu, S., Guo, Y., Zhang, Y., Hu, C., Zhang, T., Ma, T., & Huang, H. Piezocatalysis and Piezo-Photocatalysis: Catalysts Classification and Modification Strategy, Reaction Mechanism, and Practical Application. *Advanced Functional Materials*, **2020**, 30(48), 2005158.
- [2] Kaspar P., Sobola D., Částková K., Knápek A., Burda D., Orudzhev F., Hadaš Z. *Polymers*, **2020**, 12(12), 2766.

# CHELATE COPPER COMPLEXES ON THE SURFACE OF 5-NM DIAMOND PARTICLES: SYNTHESIS AND CHARACTERISATION BY XPS AND EPR METHODS

*Osipova E.V.<sup>1</sup>, Suvorkova I.E.<sup>2</sup>, Tsuji T.<sup>3</sup>, Ishiguro Y.<sup>3</sup>, Takai K.<sup>3</sup>, Osipov V.Yu.<sup>4</sup>*

<sup>1</sup>State Institute of Technology, Saint Petersburg, Russia

<sup>2</sup>Saint Petersburg State University, Saint Petersburg, Russia

<sup>3</sup>Hosei University, Department of Chemical Science and Technology Koganei, Tokyo, Japan

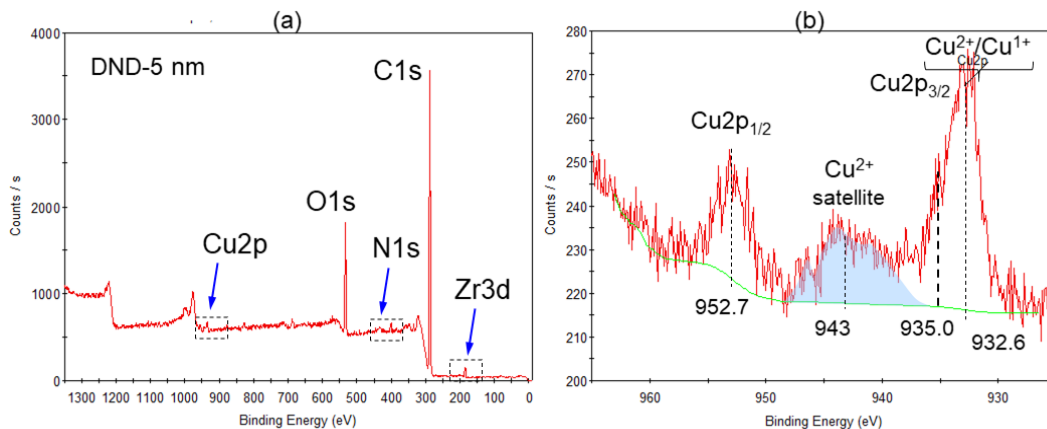
<sup>4</sup>Ioffe Institute, Saint Petersburg, Russia

Student

katyaosipova@mail.ru

The binding of copper cations to the surface of 5 nm particles of detonation diamond (DND) was first experimentally realized more than 15 years ago, and subsequently studied in detail in a number of works [1,2]. The main idea of the method is to use pairs of carboxyl groups in the composition of functional groups on the surface of DND particles to fix doubly charged cations by ion exchange with protons of carboxyl groups.

The experiment was carried out as follows. The precursors were 1 wt% DND suspension (Adamas Nanotechnologies, Inc., US) with a negative zeta potential, and crystalline hydrate  $\text{Cu}(\text{NO}_3)_2 \times 3\text{H}_2\text{O}$ . A diluted DND suspension and a 0.3 wt% saline solution taken in a certain volume were mixed with vigorous stirring. The precipitation occurred with a preliminary change in the color of the suspension from black to gray. The product precipitated during the ion exchange reaction was filtered off and dried in a vacuum. The presence of  $\text{ZrO}_2$  as a contaminating component in the suspension did not affect the binding of copper to the diamond surface. The presence of copper cations in the chelate complexes was confirmed by electron paramagnetic resonance (EPR) by observing signals from  $\text{Cu}^{2+}$  ions in the  $3d^9$  state and by X-ray photoelectron spectroscopy. The paper analyzes the parameters of the EPR signal depending on the concentration of copper chelate complexes on the surface of DND particles. The XPS spectrum of the Cu2p level of copper for one of the samples with the maximum copper content (~2.3 wt.%) is shown as an example in Fig. 1. This concentration corresponds to ca. 49 copper atoms on the surface of a particle consisting of 11500 carbon atoms.



**Figure 1.** The survey XPS spectrum of sample DND 5-nm (a) together with detailed spectrum of peak Cu2p (b) for this sample. Copper content: 2.28 wt.%. (The peak from Zr is caused by the remnants of grinding balls).

We found that only the EPR method is able to reliably and metrologically clearly detect the signal from  $\text{Cu}^{2+}$  ions on the surface of DND particles, despite the strong overlap of the high-field part of the  $\text{Cu}^{2+}$  EPR signal (from the perpendicular component) with  $g = 2.0027$  EPR signal from the spins of dangling bonds in the crystal core of DND particles. Whereas other methods give an approximate estimate of the total number of copper atoms in different charge states, including the neutral one. A special technique for separating the EPR signals from  $\text{Cu}^{2+}$  and the diamond matrix is proposed, based on heuristic assumptions about the shape of the EPR signal of DND, caused by two types of paramagnetic centers of deep and shallow occurrence.

## References

- [1] Gridnev I.D., Osipov V.Yu., Aleksenskii A.E, Vul A.Y, Enoki T. *Bull. Chem. Soc. Jpn.* 2014. 87 (6), 693-704.
- [2] Osipov V.Yu., Boukhalov D.W., Takai K. *Mendeleev Commun.* 2019. 29(4), 452-454.

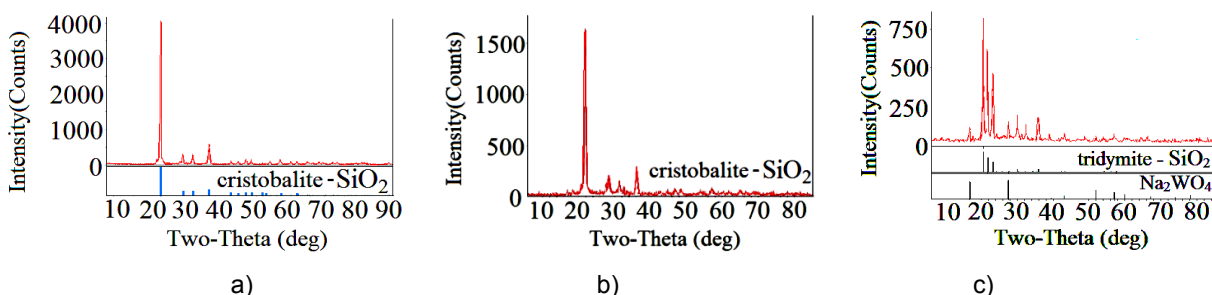
**Acknowledgements.** This work was supported by the Japan Society for the Promotion of Science (KAKENHI grants No. 16K05758, 19K05410 and 26107532) and Russian Foundation for Basic Research (project No.18-29-19038 MK).

<sup>1</sup>Institute of Catalysis and Inorganic Chemistry, Azerbaijan National Academy of Sciences, Baku, Azerbaijan<sup>2</sup>Ghent University, Ghent, Belgium

Young scientist

[o.sevinc1985@rambler.ru](mailto:o.sevinc1985@rambler.ru)

Oxidative condensation of methane (OCM) is one of the promising methods for processing natural gas into an ethane-ethylene mixture. A limiting factor in the practical implementation of the process is the low yield of target products. The best catalysts make it possible to obtain selectivity for C<sub>2</sub>-products up to 70-80% at a methane conversion of 25-30 % [1-2]. A tempting approach based on a combination of the OCM reaction to produce ethylene and carbon monoxide in the reaction products with the required CO/C<sub>2</sub>H<sub>4</sub> ratio with the hydroformylation reaction of this mixture to propylene is used in project C123 of the EU Horizon2020 program. This work presents the results of testing nanostructured oxide systems MnNaW/SiO<sub>2</sub> as catalysts for the OCM reaction to obtain gas-phase mixtures with an equimolar ratio C<sub>2</sub>H<sub>4</sub>/CO, and discusses the structural and catalytic features of the synthesized systems.



**Figure 1.** X-ray diffraction patterns of samples calcined for 4 hours: a) SiO<sub>2</sub> at 850 °C; b) SiO<sub>2</sub> at 1000 °C; c) NaMnW/SiO<sub>2</sub> at 1000 °C.

The used NaMnW/SiO<sub>2</sub> catalyst is multicomponent and, as shown by the X-ray diffractometry data, consists of the phases MnOx, Na<sub>2</sub>WO<sub>4</sub>, and SiO<sub>2</sub>. At the OCM reaction temperature, i.e. 750-850 °C, one of these phases - Na<sub>2</sub>WO<sub>4</sub> is in a melted state (the values of the melting and decomposition temperature of Na<sub>2</sub>WO<sub>4</sub> are equal to 696 and 1200 °C, respectively). The phases MnOx (MnO, Mn<sub>2</sub>O<sub>3</sub>, MnO<sub>2</sub>) and SiO<sub>2</sub> have a melting point above 850 °C, i.e. under the reaction conditions Na<sub>2</sub>WO<sub>4</sub>, covering the surface of crystalline SiO<sub>2</sub> (with cristobalite and/or tridymite structure) in the form of a film, and nanosized MnOx particles contained in it, as shown by EMR data. This example underline the peculiarities of high-temperature reactions catalyzed by multicomponent systems, the components of which are in different states of aggregation under the reaction conditions. The experimental data show the instability of phase composition of these catalysts under reaction conditions and decreasing the activity of catalysts approximately for 10-15% after 15 hours of working in OCM reaction. To use catalysts of new compositions that allow the OCM reaction to be carried out at temperatures below the ignition of ethane and ethylene (~ 600 °C), we will need to carry out studies using in-situ EPR and Raman spectroscopy in combination with mass spectroscopy of surface and gas-phase products of the OCM reaction. These studies make it possible to find ways to stabilize methyl radicals with their subsequent recombination on the surface with the formation of ethane, to separate and control the stages of recombination of methyl radicals on the surface and in the gas phase, and thereby allow controlling the OCM process. For these NaMnW/SiO<sub>2</sub> catalysts, the specific surface area was 100-120 m<sup>2</sup>/g and after 15 hours of operation at a temperature of 800-850 °C decreased significantly, but they average pore diameter is in the range of 2-50 nm still and typical for mesoporous materials. Comparison of EDX spectra indicates a noticeable effect of the temperature and duration of calcination of the samples on the distribution of catalytically active components in the catalyst structure. We consider it expedient to carry out, first of all, in situ X-ray diffraction, Raman, and EMR studies in combination with mass spectroscopic analysis of gas-phase products of the reaction to detailize, refine the "structure-activity" models of the OCM reaction with participation of NaWMn/SiO<sub>2</sub> catalysts [3].

#### References

- [1] Kondratenko E.V., Peppe T., Seeburg I.D., Kondratenko V.A., Kalevaru N., Martin A., Wohlrab S. *Catal. Sci. Technol.* **2017**, 7, 366-381
- [2] Karakaya C., Kee R.J. *Progr. Energy Combust. Sci.* **2016**, 55, 60-97
- [3] Kiani D., Sourav S., Baltrusaitis J., Wachs I.E. *ACS Catal.* **2019**, 9, 5912-5928

Acknowledgements. This work is funded by the European Union's Horizon 2020 research and innovation program under grant agreement No.814557.

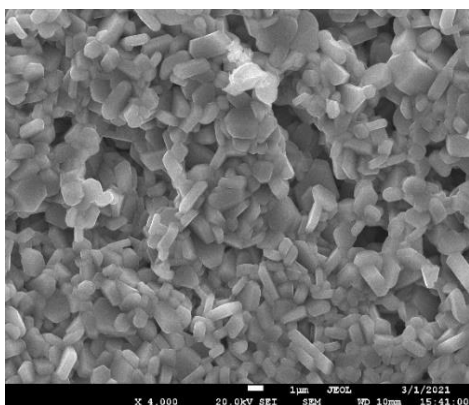
<sup>1</sup> South Ural State University, Chelyabinsk, Russia  
Graduate student  
pavlovakp@susu.ru

Hexaferrites with a magnetoplumbite structure have a hexagonal structure and the chemical formula MFe<sub>12</sub>O<sub>19</sub>, in which M is usually Ba or Sr. It is known that the magnetic and electrical properties of M-type hexaferrites can be easily controlled by doping. The process becomes more complicated when doping with a transition metal, especially in the case of Mn doping. Since Mn is a multivalent element, there may be one or more valence states in an M-type compound. For example, Mn<sup>2+</sup>, Mn<sup>3+</sup>, and Mn<sup>4+</sup> ions were found in the doped Mn (Ba, Sr)Fe<sub>12</sub>O<sub>19</sub> [1, 2]. In this work, a series of BaFe<sub>12-x</sub>Mn<sub>x</sub>O<sub>19</sub> где x = 0,1; 0,5; 1; 1,5; 2; 2,5. samples is obtained, where x = 0,1; 0,5; 1; 1,5; 2; 2,5. Their crystal structure has been studied by X-ray diffraction (XRD) and electron microscopy (SEM). The samples were obtained by solid-state reaction. Table 1 shows the elemental composition of ceramic samples, and based on electron microscopy data, it can be concluded that the specified and actual formulas are consistent.

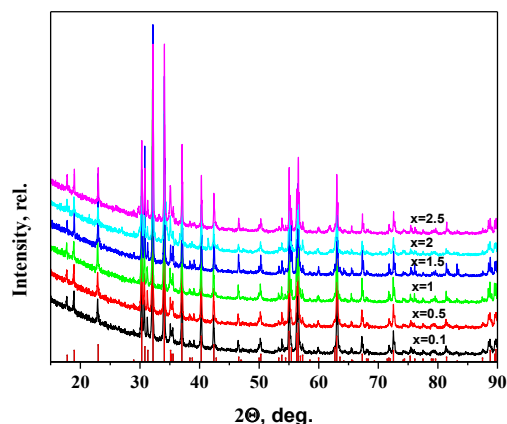
№	atom., %				Chemical Composition	Calculated brutto formula (according to EDX data)
	Mn	Fe	Ba	O		
1	0,46	42,75	3,75	53,04	BaFe <sub>11,9</sub> Mn <sub>0,1</sub> O <sub>19</sub>	BaFe <sub>11,87</sub> Mn <sub>0,13</sub> O <sub>19</sub>
2	1,74	40,28	3,62	54,37	BaFe <sub>11,5</sub> Mn <sub>0,5</sub> O <sub>19</sub>	BaFe <sub>11,5</sub> Mn <sub>0,5</sub> O <sub>19</sub>
3	3,46	37,37	3,67	55,51	BaFe <sub>11</sub> Mn <sub>1</sub> O <sub>19</sub>	BaFe <sub>10,98</sub> Mn <sub>1,02</sub> O <sub>19</sub>
4	5,37	34,98	3,53	56,11	BaFe <sub>10,5</sub> Mn <sub>1,5</sub> O <sub>19</sub>	BaFe <sub>10,4</sub> Mn <sub>1,6</sub> O <sub>19</sub>
5	6,99	36,62	3,29	53,10	BaFe <sub>10</sub> Mn <sub>2</sub> O <sub>19</sub>	BaFe <sub>10,08</sub> Mn <sub>1,92</sub> O <sub>19</sub>
6	9,20	34,07	3,41	53,33	BaFe <sub>9,5</sub> Mn <sub>2,5</sub> O <sub>19</sub>	BaFe <sub>9,45</sub> Mn <sub>2,55</sub> O <sub>19</sub>

**Table 1.** Elemental composition of a samples.

Figure 1 shows the SEM images at 4000x magnification of the manufactured sample with x = 0,1. It seems that the surface morphology is a set of soldered microparticles with a random crystal orientation. The particle size tends to increase with increasing x. There are the crystallites have the appearance of a regular hexagon.



**Figure 1.** SEM images of BaFe<sub>11,9</sub>Mn<sub>0,1</sub>O<sub>19</sub> of the sample.



**Figure 2.** Powder X-ray diffraction patterns for synthesized samples.

Figure 2 shows the X-ray diffraction curves of the samples under study. Vertical lines indicate literature data [3]. The coincidence of the positions and intensities of the reflections given in the literature and in the experimental spectra indicates that the obtained samples's structure coincides with the barium hexaferrites structure. Samples are monophasic. However, more research is needed, using sensitive instruments such as X-ray absorption spectroscopy (XAS), to find out the oxidation and substitution rates of Fe and Mn ions in the hexaferrite lattice, as well as the reason for the change in the lattice parameters as a function of x.

#### References

- [1] Nemrava S., Vinnik D.A., Hu Z., et. al. *Inorg. Chem.* **2017**, 56, 7, **3861–3866**.
- [2] Collomb A., Obradors X., Isalgué A., Fruchart D. *J. Magn. Magn. Mater.* **1987**, 69 (3), 317-324.
- [3] Wong-Ng W, McMurdie H, Paretzkin B, Hubbard C, Dragoo A. *NBS (USA)*. **1987**, ICDD Grant-in Aid. JCPDS card No. 38-1432.

Acknowledgements. This work was supported by RFBR (project number 20-38-70057). Additionally, the project was supported President's grants for young doctors of science (MD-5612.2021.4).

# MATERIALS BASED ON COMPOSITE POLY(VINYL ALCOHOL)/CHITOSAN HYDROGELS AND CALCIUM SALTS FOR USE IN TISSUE ENGINEERING

*Peranidze K.Kh.<sup>1</sup>, Safronova T.V.<sup>1</sup>, Kil'deeva N.R.<sup>2</sup>*

<sup>1</sup>Lomonosov Moscow State University, Moscow, Russia

<sup>2</sup>Kosygin Russian State University, Moscow, Russia

Student

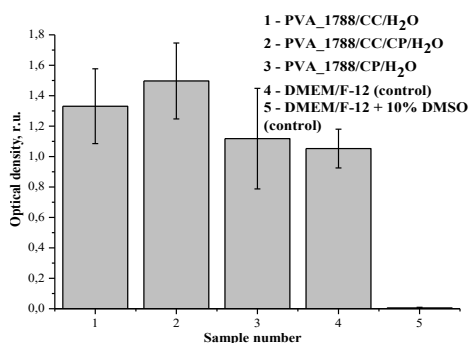
[perika5@mail.ru](mailto:perika5@mail.ru)

Over the past decade, a regenerative approach to bone tissue engineering has developed significantly by evolving the construction of bulk polymer scaffolds in combination with bioactive components that can stimulate the differentiation of donor stem cells into osteoblasts. Since the modern materials for the cell structures cultivation in vitro and for the drugs delivery to the area of bone tissue damage cannot be fully recommended for use, the search for new materials for these medical purposes, as well as methods of their manufacture is an urgent problem of the research in the field of interdisciplinary materials science.

Composite materials including a composite polymer matrix based on polyvinyl alcohol (PVA) and chitosan (Ch), and particles of synthetic calcium phosphates and carbonates (CP and CC) allow us to find an approach to solving the above-mentioned problem. Thus, the aim of this study was to develop film and fibrous materials based on PVA/Ch hydrogels filled with calcium salts. The following tasks were set to achieve the goal: to study the physical and chemical properties of composite PVA (M 120 kDa) and Ch (M 190 kDa) solutions; to develop a strategy for the synthesis of bioresorbable CP (Ca/P = 1; 1.67) and CC in viscous polymer solutions; to obtain films and fibers of composite hydrogels 'PVA/Ch/CP/H<sub>2</sub>O-CH<sub>3</sub>COOH' and 'PVA/CP/CC/H<sub>2</sub>O', and to study the properties of samples for phase composition, filler morphology and cytocompatibility.

The properties of three types of partially hydrolyzed PVA (M 42, 124, and 245 kDa) and Ch (190 kDa) were studied by viscometry, conductometry, and electrospinning using Nanospider technology in order to determine the optimal composition of the composite polymer solution and the conditions for fiber formation. Composite suspensions 'PVA/CP/H<sub>2</sub>O' and 'PVA/Ch/CP/H<sub>2</sub>O-CH<sub>3</sub>COOH' were synthesized from Ca(CH<sub>3</sub>COO)<sub>2</sub>•H<sub>2</sub>O and (NH<sub>4</sub>)<sub>2</sub>HPO<sub>4</sub> salts in aqueous PVA solutions (5, 10, and 14 wt. %) and acetic acid solutions of PVA/Ch (with the inorganic compounds mass content of 5, 10, 15 and 20 %), respectively. The preparation of 'PVA/CP/CC/H<sub>2</sub>O' suspensions for electrospinning was carried out on the basis of nanoscale powders previously synthesized in aqueous solutions.

The possibility of fiber formation from composite solutions of 'PVA/CP/CC/H<sub>2</sub>O (PVA content of 8 wt. %, U<sub>form.</sub> = 37.0 kV) and 'PVA/Ch/CP/H<sub>2</sub>O-CH<sub>3</sub>COOH' (with calcium phosphates overall content of 5 wt. %, U<sub>form.</sub> = 43.6 kV) was established by scanning electron and atomic force microscopy. At the same time, the fibers have a thickness distribution in the ranges of 190 – 530 nm and 300 – 780 nm, respectively, and the diameter of the spherical particles of CP-, CC-, and CP/CC-inclusions for each type of hydrogels does not exceed 4 μm. The special morphology of particles in the composition of film and fibrous materials, as well as the phase composition of fillers, represented by biocompatible salts CaHPO<sub>4</sub>•2H<sub>2</sub>O, Ca<sub>10</sub>(PO<sub>4</sub>)<sub>6</sub>(OH)<sub>2</sub> and/or CaCO<sub>3</sub>, provides high indicators of the metabolic activity of primary stromal cell cultures, which was confirmed by the results of colorimetric MTT-test (fig. 1).



**Figure 1.** Stromal cells metabolic activity according to MTT-test.

In the framework of this study, composite materials based on hydrogels 'PVA/Ch/CP/H<sub>2</sub>O-CH<sub>3</sub>COOH', 'PVA/CP/H<sub>2</sub>O', and 'PVA/CP/CC/H<sub>2</sub>O' were obtained. Such materials can be considered as promising model objects for further research in the field of cellular approach of bone tissue engineering.

The present research work was supported by the Russian Foundation for Basic Research (grant No. 18-29-11079).

## STRUCTURE FORMATION OF SELF-REINFORCED GYPSUM

*Petropavlovskii K.S.<sup>1,2</sup>, Novichenkova T.B.<sup>2</sup>, Petropavlovskaya V.B.<sup>3</sup>*

<sup>1</sup>Moscow State University of Civil Engineering (MGSU), Moscow, Russia

<sup>2,3</sup>Tver State Technical University, Tver, Russia

<sup>1</sup>Researcher

[kspetropavlovsky@gmail.com](mailto:kspetropavlovsky@gmail.com)

<sup>2</sup>Assistant Professor

[tanovi.69@mail.ru](mailto:tanovi.69@mail.ru)

<sup>3</sup>Professor

[victoriapetrop@gmail.com](mailto:victoriapetrop@gmail.com)

To synthesize the hardened structure of gypsum dispersed systems, the regularities of the joint formation of compounds of calcium hydrosulfoaluminate and calcium sulfate dihydrate were investigated. The shape and nature of the formed crystals of calcium hydrosulfoaluminate calcium sulfate dihydrate depend on the pH of the pore fluid [1, 2]. When the content of calcium hydroxide in the pore fluid until  $\text{pH} > 13$  is reached in a disperse system based on calcium sulfate hemihydrate, the trisulfate form of calcium hydrosulfoaluminate can be represented by extremely small prismatic crystals [3, 4]. If the content of  $\text{Ca}(\text{OH})_2$  forms a pore fluid with a  $\text{pH} < 10$ , then the structure of calcium hydrosulfoaluminate can form from fine crystals.

When forming the structure of a gypsum stone, the pH value is also an important characteristic. For example, the solubility of  $\text{CaSO}_4 \text{ II}$  in alkali solutions decreases [5]. This leads to a slowdown in the hydration of  $\text{CaSO}_4 \text{ II}$  and a decrease in the strength of binders based on it. And in the case of non-fired gypsum structures, materials have maximum strength when the pH of the pore fluid is 8 [6]. However, the effect of the pH of the medium on the properties of gypsum stone reinforced with calcium hydrosulfoaluminate crystals has been little studied.

Establishing the regularities of the influence of the pH of the dispersion medium (pore fluid) on the properties of gypsum dispersed systems reinforced with calcium hydrosulfoaluminate can provide strong materials and allow designing their compositions.

The results of the research have established that the factor that determines the pH of the dispersion medium is the percentage of calcium hydroxide  $\text{Ca}(\text{OH})_2$ . Varying the content of individual solutions of  $\text{Al}_2(\text{SO}_4)_3 \cdot 18\text{H}_2\text{O}$  and  $\text{Ca}(\text{OH})_2$  in the composition of the dispersed gypsum system determines the process of ettringite formation during the hardening of gypsum stone. Studies of the interaction of solutions of aluminum sulfate, calcium sulfate and calcium hydroxide have established that ettringite is synthesized at the first stage of gypsum hardening (up to 4 hours), at a pH of 10 to 10.5.

The strengthening of the structure of the gypsum stone occurs due to the joint formation of crystals of calcium sulfate dihydrate and the tri-sulfate form of hydrosulfoaluminate. During the crystallization of a gypsum structure based on a complex of solutions of  $\text{Al}_2(\text{SO}_4)_3 \cdot 18\text{H}_2\text{O}$  and  $\text{Ca}(\text{OH})_2$ , the number of contacts per unit volume of the crystallizing substance increases. Microscopic studies have confirmed the possibility of directional formation of ettringite crystals of various habits.

If, in the case of using the  $\text{Ca}(\text{OH})_2$  additive, the highest density of the resulting gypsum stone is achieved in the case of recrystallization of defective crystals of calcium sulfate dihydrate, then the use of a complex of  $\text{Al}_2(\text{SO}_4)_3 \cdot 18\text{H}_2\text{O}$  and  $\text{Ca}(\text{OH})_2$  solutions promotes the formation of tabular calcium sulfate dihydrate crystals and calcium hydrosulfoaluminate of fine fiber form due to the interaction of calcium sulfate hemihydrate, aluminum sulfate and calcium hydroxide.

The hardening structures of dispersed systems based on hydrosulfoaluminate and calcium sulfate dihydrate do not experience deformation while maintaining the required pH of the pore fluid. The self-reinforced structure of the stone is compacted, but not destroyed. The formation of secondary ettringite in this system is impossible due to the limited amount of the introduced aluminate component.

### References

- [1] Klimenko V.G., Pavlenko V.I., Gasanov S.K. *Middle-East Journal of Scientific Research*, **2013**, 8, 1169–1175.
- [2] Abzaev Yu.A., Sarkisov Yu.S., Kuznetsova T.V., Samchenko S.V. and atc. *Magazine of Civil Engineering*, **2014**, 47(3), 56-62.
- [3] Petropavlovskaya V.B., Novichenkova T.B., Petropavlovsky K.S., Buryanov A.F., *Construction Materials, equipment, technologies of the 21st century*, **2015**, 1(192), 15-17.
- [4] Ivanov I.I., Petrov P.P. *Organometallics*, **2016**, 35, 1684–1697.
- [5] Samchenko S., Zemskova O., Zorin D. *MATEC Web of Conferences*, **2017**, 106, 03014.
- [6] Buryanov, A.F., Petropavlovskaya, V.B., Novichenkova, T.B., Petropavlovskii, K.S. *Journal of Physics: Conference Series*, **2020**, 1425(1), 012194

Acknowledgements. This research was carried out with a grant from the Russian Science Foundation (project No. 21-79-30004)

## SYNTHESIS OF ER<sup>3+</sup> ION doped CRYSTAL POWDER Y<sub>2</sub>O<sub>3</sub> BY POLYMER – SALT METHOD

*Podrukhin J. F.<sup>1</sup>, Yevstropiev S. K.<sup>2</sup>, Bulyga D. V.<sup>2</sup>, Lepikhov B. J.<sup>3</sup>, Semencha A. V.<sup>1</sup>, Klinkov V. A.<sup>1</sup>*

<sup>1</sup>Peter the Great St. Petersburg Polytechnic University, St. Petersburg, Russia

<sup>2</sup>ITMO University, St. Petersburg, Russia

<sup>3</sup>St. Petersburg State University, St. Petersburg, Russia

Er<sup>3+</sup> ion doped crystal powder Y<sub>2</sub>O<sub>3</sub> was synthesized by polymer-salt method. The article is concerned with microstructure analysis of samples by electron microscopy, role of said method in sample's spectroscopic properties, role of Er<sup>3+</sup> ion concentration in optical quality.

Over the past few years upconversionally luminescent glowing materials became widely used in bioimaging devices and high efficiency solar panels. The development of new materials for said devices has high practical significance due to increasing scope of their uses, including laser technology, space and healthcare industries. Upconversion is a progressive combination of low-velocity photons' energy at one Gauss point followed by reradiation of high-velocity photon.

This paper is focused on developing of a simple method of synthesizing refractory oxide material powders, which would allow high accuracy control of chemical composition. Er<sub>2</sub>O<sub>3</sub>, Y<sub>2</sub>O<sub>3</sub> powders of 99,95 % and 99,99% purity respectively were used as source reagents. At the initial stage Y(NO<sub>3</sub>)<sub>3</sub> · 6H<sub>2</sub>O, Er(NO<sub>3</sub>)<sub>3</sub> · 5H<sub>2</sub>O solutions were produced, polyvinylpyrrolidone was used as a dispersing agent. Next distilled water was added to resulting solutions. Afterwards the solutions were mixed in known ratio and heated for 1 hour up to 55 °C. After aging for 19 hours at 78 °C in desiccator cabinet an orange yellow crystal powder was obtained, which was then inciderated at 1200 °C for 6 hours. Chemical analysis of powders' erbium ion content was done by energy-dispersive X-ray spectroscopy, which showed conforming to target values. Microstructure analysis demonstrated correlation between polyvinylpyrrolidone content and resulting powder's porosity.

Er<sup>3+</sup> ion doped crystal powder Y<sub>2</sub>O<sub>3</sub> was synthesized by polymer-salt method, evaporation followed by high temperature incideration. Microstructure was nonuniform and crystalline with clearly distinguishable crystal boundaries. Effect of porosity on optical quality of resulting crystal powders was established.

# THE RELATIONSHIP “CHEMICAL COMPOSITION-STRUCTURAL PARAMETERS-PHOTOCATALYTIC PROPERTIES” IN 3D-DOPED TIN DIOXIDE NANOPARTICLES

*Podurets A.A., Bobrysheva N.P., Osmolowsky M.G., Voznesenskiy M.A., Osmolovskaya O.M.*

Saint Petersburg State University, Saint Petersburg, Russia

PhD Student

[anastasiia.podurets@gmail.com](mailto:anastasiia.podurets@gmail.com)

The significant problems of the ocean pollution caused by industrial waste and reuse of wastewater requires new effective treatment systems based on use of sunlight for removing organic pollutants. The need for novel avenues in ecological water remediation has caused an active development of such an interdisciplinary field as photocatalysis due to its ability to occur in different parts of the electromagnetic spectrum. Resulted by increased demands for high-efficient photocatalysts, the implementation of wide band-gap semiconductors based on SnO<sub>2</sub> (band gap 3.7 eV) proved to be effective in a large range of photocatalytic systems [1].

According to the literature, doping of semiconductor SnO<sub>2</sub> rutile crystalline structure with 3d metals proved to be a successful tool for extending the photocatalytic response towards visible light region. Since the influence of the nature of dopants, in particular, the value of the ionic radius, on the structure and properties of tin dioxide remains not fully understood the present work aims to provide a comprehensive study of the relationship “chemical composition-structural parameters-photocatalytic properties” in 3d-doped tin dioxide nanoparticles.

To clarify this aspect, we used Ni<sup>2+</sup>, Cu<sup>2+</sup>, Co<sup>2+</sup> (11-33 mol%) as dopants for SnO<sub>2</sub> nanoparticles; the influence of pH values on synthesis results was also studied. Bare and doped SnO<sub>2</sub> NPs were obtained by the (co)precipitation method. As expected, XRD data demonstrated only rutile SnO<sub>2</sub> peaks (ICDD 00-041-1445), the crystallite sizes increased for the higher pH values. According to TEM and SSA data, the spherical nanoparticle size does not exceed 5 nm. The changes in lattice parameters indicate the success of the doping process. XPS data confirms the valence state of Sn and dopant atoms. In addition, the concentration of structural defects and oxygen vacancies was determined using Raman spectroscopy and XPS, respectively. The band gap values were determined by UV-adsorption spectra.

Positions of dopant atoms in crystal cell, which determines the energy spectrum, as well as band structures with densities of states were calculated using Castep software packages.

The photocatalytic activity of the samples was tested using methylene blue (MB) as a model pollutant under visible light source with predefined different emission spectra (683 nm, 1.83 eV). The “dark” adsorption of MB on the surface of the samples has been studied. The obtained results helped to establish for the first time that in the case of spherical nanoparticles with a diameter less than 5 nm, the main factor determining the photocatalytic activity is the ratio of «oxygen vacancies» to general defects; in the same time, for the optimal sample with 11 mol% Co obtained at pH = 3, almost complete degradation of the dye (84%) is achieved after 60 minutes using visible radiation.

## References

[1] Podurets A. et al. Enhanced visible-light photocatalytic activity of core-shell oxide nanoparticles synthesized by wet chemical precipitation and atomic layer deposition // Appl. Surf. Sci. 2020. Vol. 533, № August. P. 147520.

Acknowledgements. This work was supported by the RFBR (20-03-00762-a) and Research Park of St. Petersburg State University namely Centre for X- ray Diffraction Studies, Chemical Analysis and Materials Research Centre, Centre for Innovative Technologies of Composite Nanomaterials, Centre for Optical and Laser Materials Research, Interdisciplinary Resource Centre for Nanotechnology, Computing Centre.



# DEXTRAN-COATED GADOLINIUM-DOPED CERIUM OXIDE NANOPARTICLES AS MRI CONTRAST AGENTS WITH HIGH T1 RELAXIVITY AND SELECTIVE ANTICANCER ACTIVITY

Popov A.L.<sup>1</sup>, Ermakov A.M.<sup>1</sup>, Popova N.R.<sup>1</sup>, Ivanova O.S.<sup>2</sup>, Abakumov M.A.<sup>3</sup>, Zamyatina E.A.<sup>1</sup>, Anikina V. A.<sup>1</sup>, Baranchikov A.E.<sup>2</sup>, Kozlova T.O.<sup>2</sup>, Ivanov V.K.<sup>2</sup>

<sup>1</sup>Institute of Theoretical and Experimental Biophysics of the Russian Academy of Sciences, Pushchino, Russia

<sup>2</sup>Kurnakov Institute of General and Inorganic Chemistry of the Russian Academy of Sciences, Moscow, Russia

<sup>3</sup>Biomedical Nanomaterials Laboratory, National University of Science and Technology "MISIS", Moscow, Russia  
[antonpopovleonid@gmail.com](mailto:antonpopovleonid@gmail.com)

Gd-based complexes are widely used as magnetic resonance imaging (MRI) contrast agents [1]. The safety of previously approved contrast agents is questionable and is being re-assessed. The main causes of concern are possible gadolinium deposition in the brain and the development of systemic nephrogenic fibrosis after repeated use of MRI contrasts [2]. Thus, there is an urgent need to develop a new generation of MRI contrasts that are safe and that have high selectivity in tissue accumulation with improved local contrast.

Here, we report on a new type of theranostic MRI contrast agent - dextran stabilized, gadolinium doped cerium oxide nanoparticles. These ultra-small (4–6 nm)  $\text{Ce}_{0.9}\text{Gd}_{0.1}\text{O}_{1.95}$  nanoparticles have been shown to possess excellent colloidal stability and high  $r_1$ -relaxivity ( $3.6 \text{ mM}^{-1}\text{s}^{-1}$ ).  $\text{Ce}_{0.9}\text{Gd}_{0.1}\text{O}_{1.95}$  nanoparticles were synthesized by hydrothermal synthesis using solution of cerium (III) and gadolinium (III) nitrates with dextran as stabilizer. Being chelating ligands, dextran molecules form stable complexes with rare-earth metals and act as a capping agent, preventing the formation of large, ceria-based nanoparticles. The results of an X-ray diffraction analysis of the synthesised nanoparticles indicate the ultra-small size and crystalline nature of the nanoparticles. According to MRI measurements,  $\text{Ce}_{0.9}\text{Gd}_{0.1}\text{O}_{1.95}$  NPs in millimolar concentrations provide bright,  $T_1$ -weighted images, and  $T_1$  signal intensity correlates with the concentration of the NPs,  $T_1$  relaxivity being equal to  $3.6 \text{ mM}^{-1}\text{s}^{-1}$ , which is comparable to clinically approved gadolinium-based commercial contrast agents. FITC-labelling of the dextran shell of  $\text{Ce}_{0.9}\text{Gd}_{0.1}\text{O}_{1.95}$  nanoparticles made it possible to show their predominant intracellular localisation in the cytoplasm and lysosomes. Normal and transformed cells showed a different response to exposure to  $\text{Ce}_{0.9}\text{Gd}_{0.1}\text{O}_{1.95}$  nanoparticles. The viability of normal cells was not affected by the NPs, while a dose-dependent decrease in the viability of MCF-7 cells was observed upon exposure to high concentrations ( $>0.3 \text{ mg/ml}$ ) of  $\text{Ce}_{0.9}\text{Gd}_{0.1}\text{O}_{1.95}$  nanoparticles. This difference is probably due to the development of mitochondrial-mediated apoptosis in cancer cells, as a significant decrease in the level of their mitochondrial membrane potential was observed in the presence of  $\text{Ce}_{0.9}\text{Gd}_{0.1}\text{O}_{1.95}$  NPs. The triggering of the apoptosis mechanism in cancer cells in the presence of  $\text{Ce}_{0.9}\text{Gd}_{0.1}\text{O}_{1.95}$  NPs was confirmed by the significant increase in the expression level of the CD40 gene, indicating the activation of oxidative stress. In normal cells, incubation with  $\text{Ce}_{0.9}\text{Gd}_{0.1}\text{O}_{1.95}$  NPs did not result in any changes in mitochondrial membrane potential and reduced the level of ROS species. Both in normal and transformed cells,  $\text{Ce}_{0.9}\text{Gd}_{0.1}\text{O}_{1.95}$  NPs did not penetrate the nuclei and did not exhibit genotoxic effects. The very low hemolytic activity of dextran-coated  $\text{Ce}_{0.9}\text{Gd}_{0.1}\text{O}_{1.95}$  NPs confirmed the high level of their biocompatibility and the potential for their intravenous administration. When exposed to X-rays,  $\text{Ce}_{0.9}\text{Gd}_{0.1}\text{O}_{1.95}$  NPs showed pH dependent ROS scavenging / ROS generating properties: under slightly acidic conditions (pH 6.0), they acted as an ROS generator, while under slightly alkaline conditions (pH 8.0) they acted as a ROS scavenger, almost halving the hydrogen peroxide level in the environment.

## References

[1] Cheon J., Lee J.-H. *Acc. Chem. Res.* **2008**, *41*, 1630–1640

[2] Wahsner J., Gale E.M., Rodríguez-Rodríguez A., Caravan P. *Chem. Rev.* **2019**, *119*, 957–1057

Acknowledgements. This work was supported by Russian Foundation for Basic Research (project No 20-34-70069).

# PHOTOVOLTAIC DEVICES BASED ON POLYOXOMETALATES WITH NOBLE METALS

*Popova V.G.*<sup>1,2</sup>

<sup>1</sup>Novosibirsk State University, Novosibirsk, Russia

<sup>2</sup>Nikolaev Institute of Inorganic Chemistry of SB RAS, Novosibirsk, Russia

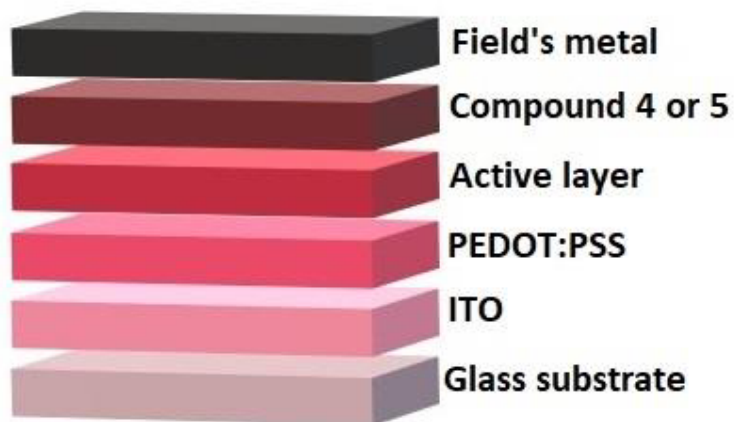
Student

[v.popova1@g.nsu.ru](mailto:v.popova1@g.nsu.ru)

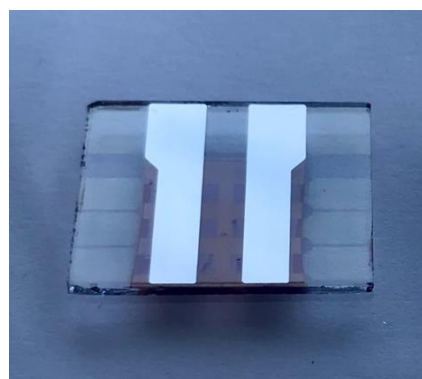
Polyoxometalates (POM) form a numerous family of polynuclear inorganic compounds, which are quite stable for multielectron oxidation-reduction, photoactive and easy to functionalize toward coordination of additional organic fragments or heterometals. These aspects take an advantage to the use such compounds in the photovoltaic cells for generating energy from renewable sources. Polyoxometalates containing noble metal ions are of interest from a lot of catalytic points of view. Moreover, presence of noble metal ions in the POM backbone significantly affects frontier orbitals energies.

Compounds based on perylene-3,4,9,10-tetracarboxylic acid diimides are also of interest for photovoltaic cells from photo- and electroactivity points of view. So, the combination of POM and perylene diimides will be a key point to create a new type materials for different applications in photovoltaics, photo/electrocatalysis, electronics etc.

In this work complexes of noble metals containing polyoxometalates and perylene based organic cations were synthesized. These compounds were used as cathode interlayers in photovoltaic cells. For the obtained solar cells the current-voltage characteristics were studied.



**Figure 1.** Scheme of photovoltaic cells.



**Figure 2.** Photovoltaic cell.

Acknowledgements. This work was supported by the Russian Science Foundation (project No 19-73-10027).

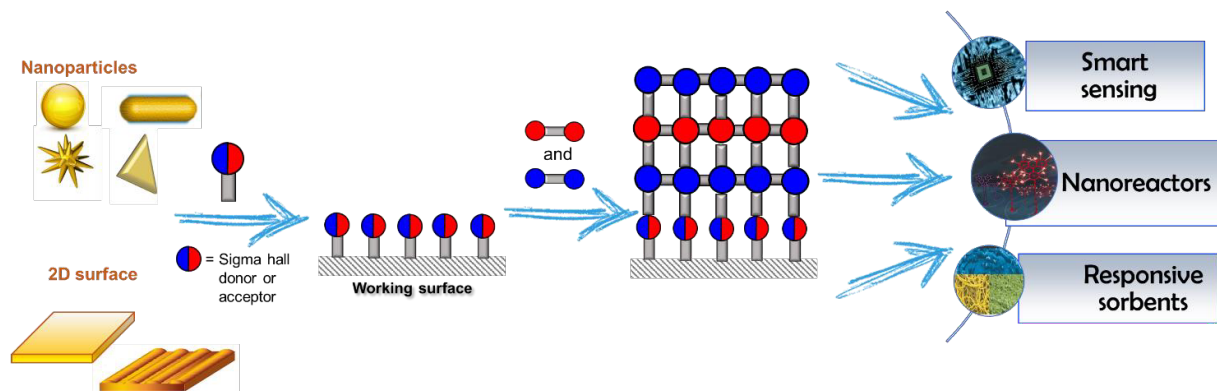
<sup>1</sup>Tomsk Polytechnic University, Tomsk, Russia<sup>2</sup>University of Chemistry and Technology, Prague, Czech Republic

Assoc. Prof.

[postnikov@tpu.ru](mailto:postnikov@tpu.ru)

The metal-organic frameworks (MOFs) can be considered as one of the bright achievements in the field of chemistry and materials science. Nowadays, MOFs are widely applied as materials for energy conversion, efficient catalysts, sorbents, and recognition elements in sensor design.

The proposed report will be dedicated to our findings in the design and preparation of surface-anchored MOFs (SurMOFs) using various substrates and materials for the targeted growth of MOF-crystals. In our studies, we preliminary modified the surface of materials by the functional groups serving as an anchor for further nucleation and crystal formation (Figure 1).



**Figure 1.** Principal scheme of SurMOFs preparation and application.

The proposed method has been implemented for the creation of various composite materials for the solution of environmental issues, from the detection of contaminants [1-5] to the generation of hydrogen [6] and sorbents [7].

### References

- [1] Guselnikova O., Postnikov P.S., Kolska Z., Zaruba K., Kohout M., Elashnikov R., Svorcik V., Lyutakov O. *Appl. Mat. Today*. **2020**, *20*, 100666
- [2] Miliutina E., Guselnikova O., Burtsev V., Elashnikov R., Postnikov P., Svorcik V., Lyutakov O. *Talanta* **2020**, *208*, 120480
- [3] Guselnikova O., Postnikov P., Elashnikov R., Miliutina E., Svorcik V., Lyutakov O. *Anal. Chim. Acta*. **2019**, *1068*, 70-79
- [4] Guselnikova O., Lim H., Na J., Eguchi M., Kim H.-G., Elashnikov R., Postnikov P., Svorcik V., Semyonov O., Miliutina E., Lyutakov O., Yamauchi Y. *Biosens. Bioelectron.* **2021**, *180*, 13109
- [5] Miliutina E., Guselnikova O., Chufistova S., Kolska Z., Elashnikov R., Burtsev V., Postnikov P., Svorcik V., Lyutakov O. *ACS Sens.* **2019**, *4*, 3133–3140
- [6] Guselnikova O., Trelin A., Miliutina E., Elashnikov R., Sajdl P., Postnikov P., Kolska Z., Svorcik V., Lyutakov O. *ACS Appl. Mat. Interf.* **2020**, *12*, 28110–28119
- [7] Semyonov O., Chaemchuen S., Ivanov A., Verpoort F., Kolska Z., Syrtanov M., Svorcik V., Yusubov M.S., Lyutakov O., Guselnikova O., Postnikov P.S. *Appl. Mat. Today* **2021**, *22*, 100910.

Acknowledgments. This work was supported by the Russian Science Foundation (project No 20-73-00151).

# MAGNETIC STRUCTURING OF MULTI-WALLED CARBON NANOTUBES IN LIQUID MEDIUMS

*Pozdeeva T.Yu., Porozova S.E., Vokhmyanin D.S.*

Perm National Research Polytechnic University, Perm, Russia  
postgraduate student  
[pozdeevatu@gmail.com](mailto:pozdeevatu@gmail.com)

Orienting of multi-walled carbon nanotubes (MWCNT) has a great potential in synthesis of liquid-based nanomaterials, like carbon-ceramics bodies casting, since MWCNT have an outstanding array of properties, such as tensile strength, bending modulus, conductivity and others, all which depend on nanotube axial direction and can be strengthened by parallel leveling using magnetic fields to improve properties of the resulting composite. CNTs have diamagnetic nature of the susceptibility, which is supposedly connected with the flow of electronic currents along their circumference [1].

Magnetic leveling of single-walled CNTs using low-power (0.1 T) magnetic fields is shown in [2].

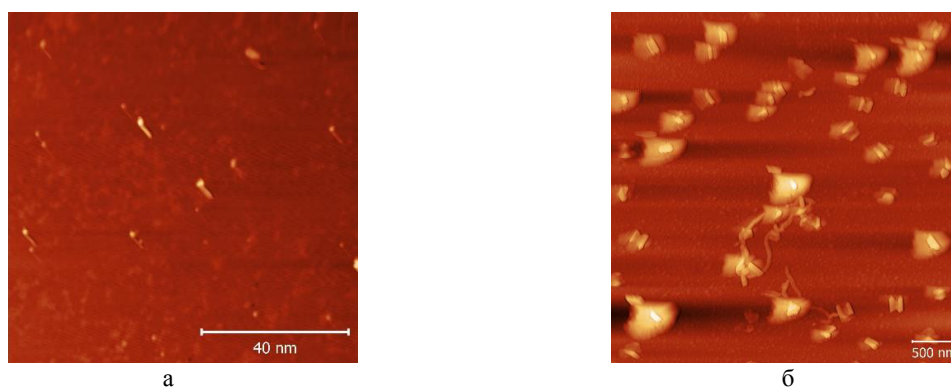
The main difficulty that limits study of CNT magnetic properties is connected with stability of suspensions allowing for long-lasting and repeatable studies in homogenous conditions.

In this work, the MWCNT of the "Taunit-M" (LLC "NanoTechCenter", Tambov) trademark was used. Aqueous dispersions of MWCNT based on non-ionic surfactants (Tween-80) and ammonium persulfate ((NH<sub>4</sub>)<sub>2</sub>S<sub>2</sub>O<sub>8</sub>) were homogenized using an ultrasonic dispersant UZDN-2T for 30 minutes according to the method [3].

For the experiment to study the susceptibility of MWCNT to the effects of a magnetic field in a liquid medium, magnets with a constant magnetic field with an induction of 2 to 5  $\mu$ T were used, registered using a magnetometer with a spatially fixing sensor. The arrangement of the magnets relative to the substrates with applied suspensions also differed: for a Tween-80 based suspension, two magnets were located opposite each other, in the case of suspension with (NH<sub>4</sub>)<sub>2</sub>S<sub>2</sub>O<sub>8</sub>, one magnet was located at the bottom relative to the substrate.

The analysis of MWCNT dispersions deposited on a glass substrate after magnetic exposure was studied using Solver Next (NT (MDT, Russia) scanning probe microscope in atomic-force semi-contact mode. Data processing was carried out using the software Gwyddion (<https://континентсвободы.рф>).

According to obtained images (Fig. 1 a, b), the orientation of MWCNT agglomerates in the direction of magnetic field lines is visible, which indicates that carbon nanotubes in liquid bodies have high susceptibility to magnetic fields comparable to the Earth's magnetic field.



**Figure 1.** AFM images of MWCNT in Tween-80 based suspensions (a) and (NH<sub>4</sub>)<sub>2</sub>S<sub>2</sub>O<sub>8</sub> (b) after magnetic structuring.

## References

- [1] *Artificial carbon materials*, **2009**, 342.
- [2] *Angew. Chem. Int. Ed.* **2008**, 47, 5148–5152.
- [3] *PNRPU Bulletin. Mechanical engineering, materials science*, **2020**, 2, 23–30.

Acknowledgements: The work was carried out with the financial support of the Russian Foundation for Basic Research (project No. 20-33-90085).

*Pozhitkova A.V., Kladko D.V., Vinogradov V.V.*

ITMO University, Saint Petersburg, Russia  
Student

[pozhitkova@scamt-itmo.ru](mailto:pozhitkova@scamt-itmo.ru)

Thrombosis-related diseases are the leading death cause in the world [1]. However, there is still a need for thrombosis treatment development due to the invasive nature of existing methods, which leads to significant deadly consequences, such as infection, excess bleeding, re-formation of a blood clot and damage to the blood vessel at the site of the blood clot. The development of effective and safe minimally invasive thrombosis treatment is still challenging task and small-scale soft material robots are attracting widespread interest in this field due to their fast response, remote actuation, and large penetration range [2]. This paper presents a minimally invasive programmable magnetic soft catheter for thrombus extraction *in vitro*. We have developed new composition and programming techniques for such magnetic materials. We further demonstrate the applicability of our system for thrombus extraction tasks, in particular the navigation through vessel-mimicking system, penetration the plasma clot under the application of a rotating magnetic field and its extraction from the vascular phantom.

Our proposed composite consists of elastomer matrix containing ferromagnetic nanoparticles, encapsulated with a phase change polymer. For our task the spiral composite form is needed to drill a clot like a screwdriver. To get necessary form of the composite under applied magnetic field we use special programming process. This approach is based on the changing of magnetization patterns in the soft material by heating the structure and shaping it into any desired form while it cools under an external magnetic field. Thus, we change the directions of magnetic domains and, therefore, the composite magnetization. The concept of our work is to insert such magnetic material into the model blood vessel, deliver it to the blockage site (the fibrin clot), using an external magnetic field. Then we will shape our system from usual strip to spiral form, which is the most suitable for our task, and using a rotating magnetic field we hook the clot and after that extract it from the vessel-mimicking system.

As a result, for composite realization we have selected, optimized and characterized magnetic FeCo nanoparticles through scanning electron microscopy (SEM), X-ray diffraction analysis (XRD) and SQUID magnetometry. Accordingly, to the SEM images, the particles form long chains and the mean size of the length and width of each chain were in the range of 1–7  $\mu\text{m}$  and 0.1–0.2  $\mu\text{m}$ . According to the XRD patterns, one diffraction peak at  $2\theta$  values of  $44.83^\circ$  corresponding to the crystal planes of (110) can be observed. The main phase of the sample is wairauite (FeCo) with a crystallite size of 22 nm, calculated by Scherrer formula. The nonlinear hysteresis loop with small nonzero remnant magnetization (4.98 emu/g) and coercivity (33 Oe) shows well pronounced ferromagnetic properties for particles with high saturation magnetization (83.46 emu/g). Moreover, we have estimated the mechanical and programming properties of the composite through the mechanical testing machine and have chosen the most suitable particle volume fraction for our material in terms of programmability and elasticity. Furthermore, the new programming technique has been developed via specially implemented magnetic setup, which magnetic properties have been analyzed through the COMSOL Multiphysics 5.5 software. Reprogrammable soft composite has been tested in different magnetic fields using special custom-build TOR 3D device, which consists of three pairs of axially-positioned Helmholtz coils, producing magnetic fields in different directions. Also, in the experiments with plasma clots the magnetic soft catheter is stated to have hooked the clot for 4 minutes without thrombolytic.

In conclusion we identified that our soft magnetic material can be reprogrammed and it has been experimentally proven that this material can be used for thrombus extraction. Such results give new opportunities to develop minimally invasive surgery for thrombosis therapy, which will be less harmful and more comfortable for people.

Acknowledgements. This work was supported by the Ministry of Science and Higher Education of Russian Federation, goszadanie no. 2019-1075

#### References

- [1] G. E. Raskob, P. Angchaisuksiri, A. N. Blanco, H. Buller, A. Gallus, B. J. Hunt, E. M. Hylek, A. Kakkar, S. V. Konstantinides, M. McCumber, Y. Ozaki, A. Wendelboe and J. I. Weitz, *Arterioscler. Thromb. Vasc. Biol.*, 2014, 34, 2363–2371.
- [2] S. L. Charreyron, E. Gabbi, Q. Boehler, M. Becker and B. J. Nelson, *IEEE Robot. Autom. Lett.*, 2019, 4, 284–290.

MODIFICATION OF PVC PLASTICIZED MEMBRANES USING Fe<sub>3</sub>O<sub>4</sub>@HAp NANOPARTICLES FOR ANION-SELECTIVE SENSING

*Rashitova K.I.<sup>1</sup>, Kirsanov D.O.<sup>1</sup>, Osmolovskaya O.M.<sup>1</sup>*

<sup>1</sup>Saint Petersburg State University, Saint Petersburg, Russia

Student

[RashitovaKI@gmail.com](mailto:RashitovaKI@gmail.com)

The determination of anions such as carbonates, sulfates, and phosphates in aqueous media is an important analytical problem in biomedical and environmental research. Currently, for its reliable solution, expensive instrumental methods are used, for example ion exchange chromatography, capillary electrophoresis, etc.

Chemical sensors - ion-selective electrodes (ISE) - are a perspective alternative to these methods, as they are cost-effective, easy-to-use devices that allow express and accurate analysis of chemical species in a wide concentration range with high selectivity. Another advantage is the ability to control sensor properties within a wide range by changing the composition of the electrode membrane.

Currently, the most widespread type of ISE are electrodes with plasticized polymeric membranes, which include various lipophilic ligands and ion-exchangers. A large number of various sensors of this type have been developed for the determination of inorganic cations and anions; however, the development of sensors that are highly selective for hydrophilic anions is a difficult and still unsolved problem, since such ions have a low affinity for lipophilic sensor membranes. Despite the development of sensors based on neutral lipophilic ligands with high selectivity to hydrocarbonate and sulfate, their use in real media is still strongly limited by the interfering effect of other anions.

Here we propose to use core-shell nanoparticles for sensor membrane modification, because such structures demonstrate the special state of the material of the shell, allowing to obtain the materials with unique properties. Magnetite was chosen as the core, since it is a good semiconductor, while having a small size, which will increase the area capable of interacting with the analyte. To obtain the shell, hydroxyapatite (HAp), doped with 3d- and 4f-elements (Cr<sup>3+</sup>, Fe<sup>3+</sup>, Al<sup>3+</sup>, Tb<sup>3+</sup>, La<sup>3+</sup>, Gd<sup>3+</sup>), were used. These metal ions as well as Ca<sup>2+</sup> presented in HAP have a high affinity for hydrophilic anions. It was expected that they will interact in a reversible way with anions in a sample to produce an electrochemical response. It was also expected that the modification of hydrophobic membranes with hydrophilic nanoparticles may lead to a change in hydrophobicity, which will reduce the detection limit of analytes.

Magnetic core-shell Fe<sub>3</sub>O<sub>4</sub>@HAp nanoparticles with different dopant ions were synthesized using a co-precipitation method. NP morphological parameters were characterized using X-ray diffraction (XRD) and Fourier-transform infrared spectroscopy (FTIR), transmission electronic microscopy (TEM), specific surface area estimation (SSA), dynamic light scattering (DLS). The presence of crystalline magnetite core and amorphous HAp shell has been shown.

Synthesized nanoparticles were used to modify polyvinyl chloride (PVC) plasticized membranes. The electrochemical properties (sensitivity, selectivity, detection limits) of modified membranes were studied in aqueous solutions (pH=7 and 4) of a wide range of inorganic anions. It was shown that the presence of nanoparticles in the membrane promotes an anionic response in the presence of hydrophilic anions. The obtained response depends on the nature and composition of the nanoparticles used to modify ISEs. The detailed results will be reported in the presentation.

Acknowledgements. The authors of the work express their gratitude to the RC of the Science Park of St. Petersburg State University "X-ray diffraction research methods", "Methods of analysis of the composition of matter."

# SYNTHESIS, STRUCTURE AND PROPERTIES OF THIN FILM MULTIFERROIC MATERIALS BASED ON HEXAGONAL LUTETIUM FERRITE

Ratovskiy V.Y.<sup>1</sup>, Nigaard R.R.<sup>1</sup>, Kaul A.R.<sup>2</sup>

Moscow State University, Moscow, Russia

<sup>1</sup>Faculty of Materials Sciences

<sup>2</sup>Department of Chemistry

Student

[vratovskiy@bk.ru](mailto:vratovskiy@bk.ru)

Hexagonal lutetium ferrite (h-LuFeO<sub>3</sub>) is an unstable phase that can be epitaxially stabilized on single crystal substrates of coherent structure. This compound arouses great interest due to its magnetoelectric coupling – the reciprocal influence of a magnetic (electric) field on the polarization (magnetization) of a material. The main obstacle for practical application is the antiferromagnetic spin structure of the compound with a triangular arrangement of moments in the a-b plane. However, it was previously reported that the magnetic moment of h-LuFeO<sub>3</sub> can be greatly increased by doping with indium, nickel or zirconium [1-2]. In addition, the ability of h-LuFeO<sub>3</sub> to form layered epitaxial heterostructures with ferrimagnetic spinels (for example, Fe<sub>3</sub>O<sub>4</sub>) can serve as a basis for creating composite multiferroics with a high magnetoelectric coupling coefficient.

The goals of this study were formulated as follows: deposition of h-LuFeO<sub>3</sub> thin films with Ni, Zr and Sc gradient doping, deposition of h-LuFeO<sub>3</sub> heterostructures with iron oxides on single-crystal substrates YSZ (111) and YSZ (100), study of the crystallographic growth orientation, microstructure and magnetic properties of the obtained samples.

The deposition of thin films was carried out at 900°C by the low-pressure MOCVD method in the setup with a vertical hot-wall reactor and with a novel feeding device. Cotton thread was pulled through a precursors solution in toluene, the solvent was immediately evaporated upon entering the setup. Covered in crystallized precursor thread then entered the evaporation zone, where precursor was sublimated and its vapors transferred to the deposition zone. Chelate complexes of Lu, Fe, Ni, and Zr with dipivaloylmethane were used as precursors, argon was the carrier gas, oxygen was supplied into the reactor separately. Doping was carried out in two ways: gradient and uniform. In the first case, the dopant precursor was gradually added to the initial solution of precursors after certain time intervals, which provided a gradient of the dopant concentration over the thickness of the films. In the second case, the deposition was carried out using a precursor solution, which already contained the required amount of the dopant.

In this research, the microstructure, phase composition, and magnetization (M) of the obtained thin films were investigated. The presence of magnetic transition at 57 K in the M-T curve is in good agreement with the literature data and, to our knowledge, this transition is demonstrated for h-LuFeO<sub>3</sub> thin films for the first time. The h-LuFeO<sub>3</sub> peaks in the diffraction patterns of the samples doped with Ni and Zr are shifted to the smaller angles, which indicates an increase in the parameter c, which, in turn, indicates that in both cases iron sublattice was doped as shows the formula h-LuFe<sub>1-x</sub>Me<sub>x</sub>O<sub>3</sub> (Me=Ni, Zr). In case of Lu sublattice gradient doping with Sc<sup>+3</sup>-ions, the unusually high width of the hexagonal phase reflections in the XRD spectrum is observed, which might suggest the success of the gradient doping method.

In this study, the epitaxial growth of metastable β-Fe<sub>2</sub>O<sub>3</sub> on the surface of h-LuFeO<sub>3</sub> was demonstrated for the first time. The XRD of the heterostructures demonstrate an oriented growth of the β-Fe<sub>2</sub>O<sub>3</sub> phase on the h-LuFeO<sub>3</sub> surface. It was also discovered that the direction of growth of the iron oxide phase depends on the substrate used to stabilize the hexagonal phase. A successful attempt of subsequent growth of h-LuFeO<sub>3</sub> on the β-Fe<sub>2</sub>O<sub>3</sub> surface indicates a potential way to overcome the critical thickness limit of the epitaxially stabilized hexagonal phase using the creation of multilayer epitaxial heterostructures. The study of doped samples demonstrates successful substitution in the iron sublattice, as well as the success of the gradient method of varying the composition over thickness of the film.

## References

[1] Liu J., Sun T.L., Liu X.Q., Tian H., Gao T.T. *Advanced Functional Materials* **2018**, 28, 1–10.

[2] Suresh P., Vijaya Laxmi K., Anil Kumar. P.S. *Journal of Magnetism and Magnetic Materials* **2018**, 448, 117–122.

COMMUNICATING PARTICLES:  
IDENTIFICATION TAGGANT AND TEMPERATURE RECORDER IN ONE SINGLE SUPRAPARTICLE

Reichstein J.<sup>1</sup>, Miller F.<sup>1</sup>, Wintzheimer S.<sup>1,2</sup>, Mandel K.<sup>1,2</sup>

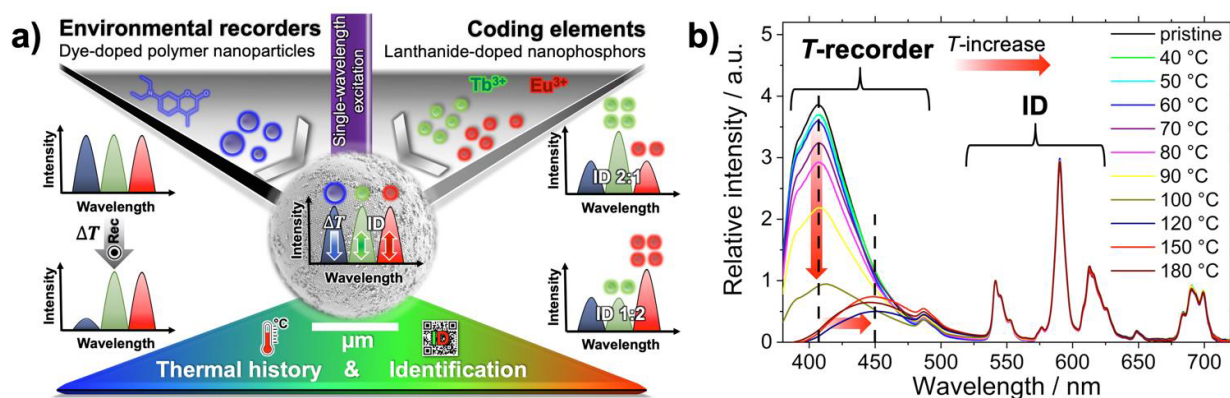
<sup>1</sup>Friedrich-Alexander University Erlangen-Nürnberg (FAU), Erlangen, Germany

<sup>2</sup>Fraunhofer Institute for Silicate Research ISC, Würzburg, Germany

[karl.mandel@fau.de](mailto:karl.mandel@fau.de)

A transformation of passive items into smart systems is required to ultimately realize innovative concepts, like *Industry 4.0* or *Circular economy*, that contribute to the desired transition into an age of sustainability [1]. One promising approach to succeed in this endeavor is to render matter conscious, materials intelligent and enable them to communicate. More precisely, with a tailored, flexibly applicable *smart additive*, any random object could be equipped with intelligence. In this presentation we introduce micron-scaled *communicating particles (CPs)* as smart additives that unite the functionalities of an identification (ID) taggant and a thermal history recorder within their luminescent signal characteristic [2]. Therefore, the information capacity of established ID markers is substantially increased to give rise to innovative applications in various fields, such as traceability and quality control of goods [3]. Furthermore, targeted repair measures by indication of broken subcomponents, respectively predicted maintenance could be realized, even when a product is of complex structure.

Key to unite the two functionalities in a single particle and enable their simultaneous read-out, using single-wavelength excitation, is the hybrid inorganic-organic nature of the CPs. Three different types of spectrally distinguishable luminescent nanoparticles are assembled into microparticles with a hierarchical core-satellite structure, so called supraparticles, via a scalable two-step droplet evaporation technique (spray-drying) (Figure 1a). The ID functionality in the supraparticle core, based on  $\text{CaF}_2:\text{Tb}^{3+}$  and  $\text{CaF}_2:\text{Eu}^{3+}$  nanophosphors, is demonstrated to be inert towards temperature changes. Coumarin 1-doped polymer nanoparticles, acting as the CPs temperature recorder satellites, show an intense blue luminescence that is irreversibly quenched upon exposure to temperatures exceeding a specific threshold. Thus, the combined signal response of the CPs allows for simultaneous monitoring of the particles *identity* and elapsed *thermal history* (Figure 1b). The applied ratiometric detection of both functionalities provides reliable information even at low analyte concentrations. Furthermore, the CPs toolbox-like design enables the readily adjustment of both functionalities. Altering the weight ratio of the two coding elements leads to a huge variety of unique ID signals. The sensitivity of the temperature recorder satellites can be tailored toward specific applications over a wide temperature range by simply varying the C1-hosting polymeric material. In summary, the presented CPs and their underlying conceptual design give rise to an entire new family of hierarchical structured, multi-functional, and stimuli-responsive particles, applicable as smart additives to foster *materials' intelligence*.



**Figure 1.** Design of a micron-scaled communicating supraparticle (CP), combining the functionalities of an ID taggant and a temperature recorder in one luminescent entity by defined assembly of three spectrally distinguishable luminescent nanoparticle types (a); temperature dependent luminescent signal characteristic of the CP revealing a temperature stable ID signal in the green and red wavelength area, while showing a defined irreversible signal decrease upon thermal treatment in the blue wavelength area, that allows to recorder the thermal history of their environment (b).

### References

- [1] Wintzheimer S., Reichstein J., et al. *Adv. Funct. Mater.* **2021**, 31, 2011089
- [2] Reichstein J., Miller F., et al. *Adv. Funct. Mater.* **2021**, just accepted
- [3] Miller F., Wintzheimer S., et al. *ACS Appl. Nano Mater.* **2020**, 3, 1, 734–741

This work was financially supported by the BMBF NanoMatFutur Grant 03XP0149 and the PhD scholarship for Jakob Reichstein from the German Federal Environmental Foundation.



# SYNTHESIS OF LOW-SILICA ZEOLITES FROM NATURAL HALLOYSITE NANOTUBES

*Rubtsova M.I., Boev S.S., Glotov A.P.*

Gubkin Russian State University of Oil and Gas, Moscow, Russia  
[artemovamai@gmail.com](mailto:artemovamai@gmail.com)

**Introduction:** Low-silica zeolites with a Si/Al ratio of ~1-2 are widely used as adsorbents for purification of industrial wastewater from heavy metal cations. Among them, analcime (ANA) with the chemical formula  $\text{Na}[\text{AlSi}_2\text{O}_6] \cdot n\text{H}_2\text{O}$  has the highest ion-exchange capacity and the smallest pore size (2.6 Å), which makes it an excellent sorbent for  $\text{Mn}^{2+}$ ,  $\text{Cs}^+$  and  $\text{Cd}^{2+}$  ions [1].

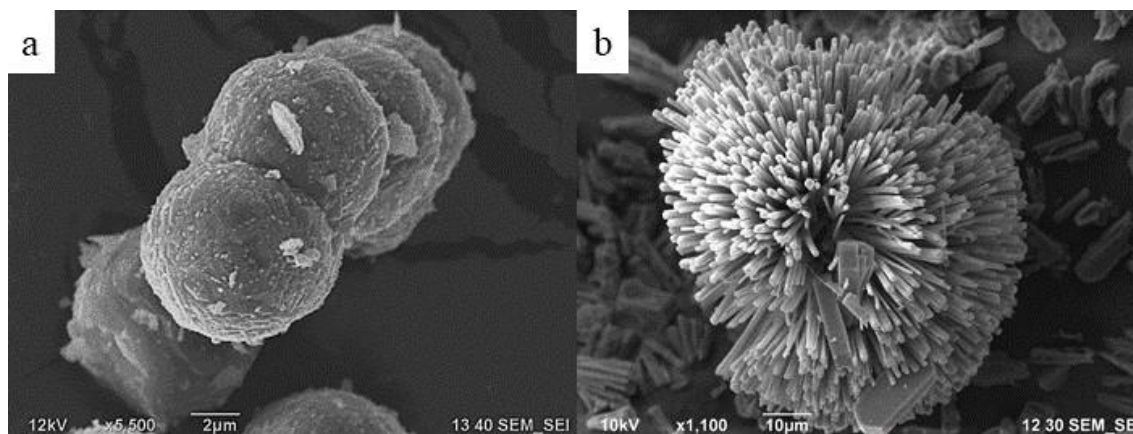
The growing demand for zeolites, together with stricter environmental requirements, have led to the fact that more and more attention has recently been paid to cheap precursors of natural origin [2]. Taking into account the required composition of the gel for ANA, the most suitable raw materials for the synthesis of analcime are materials belonging to the family of kaolin clays. In this work, natural mineral halloysite with the formula of  $\text{Al}_4[\text{Si}_4\text{O}_{10}](\text{OH})_6 \cdot n\text{H}_2\text{O}$  was applied as a precursor for the synthesis of analcime. Halloysite nanotubes (HNT) formed by rolled kaolin plates have different compositions and charges of the outer (Si-O) and inner (Al-OH) surfaces. The unique structure of HNTs opens up wide opportunities for its modification by various methods in order to impart the necessary properties to materials based on it. [3]

**Methods:** Within this study, HNTs were subjected to preliminary thermal and chemical (acid) treatment in order to control the Si/Al ratio. The obtained samples were recrystallized into analcime under hydrothermal conditions (samples Z1-Z4). Since acid treatment is not the only way to regulate Si/Al, an experiment was carried out in which halloysite was recrystallized in the presence of tetraethoxysilane (TEOS) as an additional source of silicon to obtain a Si/Al = 2 ratio in the final gel (sample Z5).

All the samples were characterized by a wide range of physicochemical methods of analysis: X-ray fluorescence spectrometry, transmission and scanning electron microscopy (SEM), X-ray diffraction analysis, thermogravimetric analysis. The dependences of the elemental composition, structure and morphology of the obtained samples on the properties of the initial halloysite were established.

**Results:** It was found that thermally activated halloysite with Si/Al ratio of 0.9 recrystallizes into a low-silica zeolite sodalite. In the case of acid pretreatment, recrystallization proceeds in the direction of the formation of analcime with the morphology of spheres (Fig. 1a), and the maximum degree of crystallinity was achieved in the case of acid etching with 2M  $\text{H}_2\text{SO}_4$ .

According to X-ray diffraction data, the sample Z5 obtained with TEOS also possessed ANA structure, but its crystals looked like radially directed rays (Fig.1b). Based on the results obtained, it can be assumed that TEOS acts as a co-template responsible for the formation of crystals of an unusual configuration.



**Figure 1.** SEM images of samples Z3 (a) and Z5 (b)

**Conclusions:** Thus, halloysite can act as a good precursor for low-silica zeolites (sodalite and analcime) synthesis. Preliminary dealumination of the tubes contributes to an increase in the crystallinity of them-based analcime. Application of TEOS as an additional source of silicon leads to the formation of crystals consisting of radially directed rods.

## References

- [1] *Journal of Siberian Federal University*. **2019**, 12(3), 347–363
- [2] *Appl. Clay Sci.* **2012**, 61, 8-13
- [3] *Ind. Eng. Chem. Res.* **2017**, 56(47), 14043–14052

**Acknowledgements.** This work was supported by the Russian Science Foundation (project No 14.Z50.31.0035).

# AIR-FILLED ALBUMIN MICROBUBBLES STABILIZED WITH GOLD NANOPARTICLES AND PHOTODYNAMIC DYE FOR THERANOSTICS DEMANDS

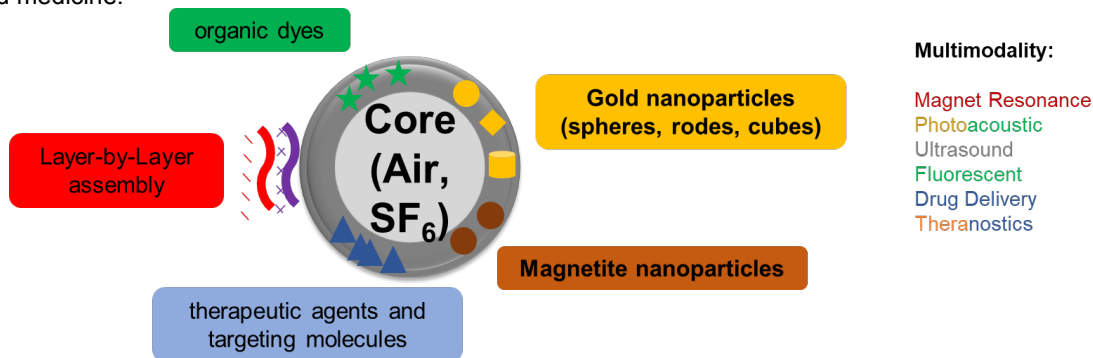
*Rudakovskaya P., Barmin R., Gusliakova O., Sindeeva O., Prikhozhenko E., Maksimova E., Obukhova E., Chernyshev V., Khlebtsov B., Sukhorukov G., Gorin D.*

Skolkovo Institute of Science and Technology, Moscow, Russia  
Young Scientist  
[p.rudakovskaya@skoltech.ru](mailto:p.rudakovskaya@skoltech.ru)

Ultrasound imaging now is one of the most frequently used diagnostic techniques in clinical practice due to its non-invasiveness, low cost and the absence of radiation. Various structures can be used as contrast agents in ultrasound imaging but one of the most promising substances are gas-filled microbubbles of different shell composition. Microbubbles' solutions possess high echogenicity (good acoustic response) and meet all specific requirements for intravenous injection into a living body hence, facilitating high-resolution real-time imaging. Microbubbles-based contrast agents have already been in use in a wide range of diagnostic applications in clinical practice (e.g., SonoVue, Optison, Albutex trade marks).

However, the idea of the merging two or more imaging techniques with therapeutic agents in one substance has become an object of growing interest recent years. For instance, microbubbles labeled with fluorescent dyes can be used for bimodal ultrasound/fluorescence imaging contrast agent design, while implementing of gold nanoparticles gives an opportunity to visualize tissues with the use of photoacoustic response. The embedding of photodynamic dyes into the microbubble shell provides the possibility of simultaneous ultrasound diagnosis and photodynamic therapy of tumors and inflammations. Moreover, the development of novel contrast agents consisting of more than two functional modality represents important and interesting, but challenging task.

In this work, two types of organic substances (low molecular weight synthetic surfactants and natural biopolymer) were selected to obtain stable bubbles providing the required ultrasonic contrast. To ensure multimodality, various inclusions were studied: fluorescent dyes (fluorescein, rhodamine, cyanine 5.5, cyanine 7), including agents for imaging and photodynamic therapy (indocyanine green), golosens (PcZn) and nanoparticles (magnetite (spherical particles, 9 nm). Diameter), gold (particles of different morphology)). The introduction of functional objects was carried out due to covalent binding with a protein, as well as due to the formation of a protein shell on the surface of nanoparticles. The obtained microbubbles were characterized by various physicochemical methods, the size of the bubbles has a narrow distribution and is about 1  $\mu\text{m}$ , the concentration of bubbles is  $10^8$ - $10^9$  ml<sup>-1</sup>, the control of the zeta potential and the concentration of bubbles made it possible to reliably determine the stability of microbubbles during prolonged (up to 47 days) storage period. All microbubble imaging has demonstrated multimodality and potential applications in biology and medicine.



## References

- [1] Barmin, R. A., Rudakovskaya, P. G., Chernyshev, V. S., Guslyakova, O. I., Belcov, P. A., Obukhova, E. N., Gayer, A. V., Shirshin, E. A., & Gorin, D. A. (2021). Optoacoustic/Fluorescent/Acoustic Imaging Probe Based on Air-Filled Bubbles Functionalized with Gold Nanorods and Fluorescein Isothiocyanate. *ACS Omega*, 6(5), 3809–3821.
- [2] Barmin, R., Rudakovskaya, P., Gusliakova, O., Sindeeva, O., Prikhozhenko, E., Maksimova, E., Obukhova, E., Chernyshev, V., Khlebtsov, B., Solovov, A., Sukhorukov, G., & Gorin, D. (2021). Air-Filled Bubbles Stabilized by Gold Nanoparticle/Photodynamic Dye Hybrid Structures for Theranostics. *Nanomaterials*, 11(2), 415.

Acknowledgements. This work was supported by the Russian Foundation for Basic Research (RFBR grant 19-53-80047 BRICS\_t)

## SYNTHESIS OF A NEW POLYANILINE-BASED COMPOSITE

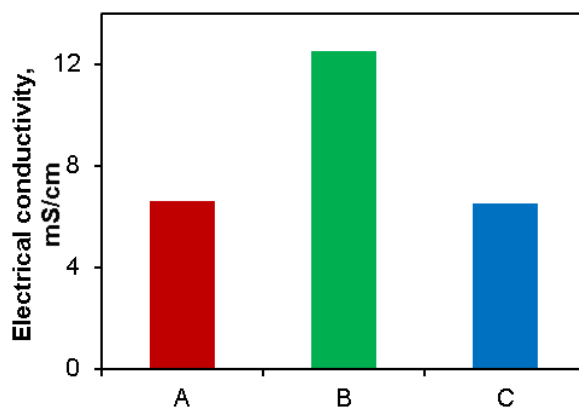
*Sadykov T.T., Andrianova A.N., Mustafin A.G.*

Bashkir State University, Ufa, Russia  
PhD Student  
gttima@mail.ru

Conjugated polymer composites are of great interest because of their potential for combining properties that are difficult to achieve with individual components. Conductive polymers have shown promising results in a variety of applications such as LEDs, chemical sensors, anti-corrosion coatings, batteries and capacitors [1].

Obtaining composites based on polyaniline (PANI) - an electrically conductive polymer is of considerable interest due to the ease of synthesis, ionic and electronic conductivity, chemical and thermal stability, resistance to environmental conditions and the ability to enter into both acid-base and redox interactions [2].

In the presented work, the synthesis of PANI – sample **A**, as well as composites based on it with sulfur particles, was carried out [3]. During the synthesis of sample **B**, sulfur was obtained directly in an aqueous solution of aniline by adding lithium polysulfide. The synthesis of composite **C** was carried out in the presence of sulfur particles, previously obtained by the method [4]. The results of studying the electrical conductivity of the synthesized samples are shown in Fig. 1.



**Figure 1.** The value of the electrical conductivity of the samples.

An increase in the conductivity of the composite (B ~ 12.5 mS/cm) obtained on the basis of lithium polysulfide relative to pure PANI is probably due to the presence of not only sulfur, but also metal ions in the material. While the use of pure sulfur in the process of PANI synthesis leads to a decrease in conductivity (C ~ 6.4 mS/cm), due to the dielectric nature of sulfur, in comparison with pure PANI.

Thus, the production of composites based on PANI and nanosulfur by the *in situ* sulfur synthesis method is a promising direction in the development of new materials that can find application in various fields of organic electronics.

### References

- [1] Li K., Guo D., Chen J., Kong Y., Xue H. *Synthetic Metals.* **2015**, *209*, 555-560
- [2] Palaniappan S., John A. *Prog. Polym. Sci.* **2008**, *7*, 732-758
- [3] Massalimov I.A., Mustafin A.G., Shangareeva A.R., Khusainov A.N. Method of producing colloidal nanosized sulphur. RU Patent №2456231, **20.07.2012**.
- [4] Mustafin A.G., Sadykov T.T., Andrianova A.N., Biglova Y.N., Massalimov I.A., Akhmetshin B.S., Abdrakhmanov I.B. Method of producing an electrically conductive composite based on polyaniline and nanosized sulfur. RU Patent Application №2020143286, **25.12.2020**.

Acknowledgements. This work was supported by Russian Foundation for Basic Research (project No 20-33-90316\20).

# PLASMONIC CORE@SHELL NANOPARTICLES LOADED WITH CISPLATIN AS MULTIFUNCTIONAL NANOSTRUCTURES FOR CANCER TREATMENT

*Salavatov N.A., Dement'eva O.V., Rudoy V. M.*

Frumkin Institute of Physical Chemistry and Electrochemistry, Russian Academy of Sciences, Moscow, Russia

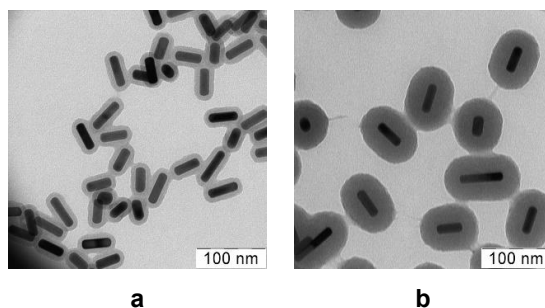
PhD Student

[gop--nick@yandex.ru](mailto:gop--nick@yandex.ru)

The application of nanoparticles opens up new possibilities in biomedicine, photovoltaics, catalysis, etc. Recently, special attention has been paid to core@shell nanoparticles which combined several functions (e.g. to act as imaging and drug delivery system simultaneously). The commonly known type of such nanostructures is nanoparticles with a noble metal core (for example, gold nanorod) and a silica shell. The main property of gold nanorods is longitudinal localized surface plasmon resonance (LSPR). The position of the LSPR band depends on their aspect ratio and can be easily “tuned” in the visible and near-IR spectral region including the tissue transparency window. This feature makes gold nanorods very promising agents for optical diagnostics and photothermal therapy of tumors. In turn, the ability of the silica shell to serve as a container for various molecules (such as dyes, drugs, etc.) makes it possible to significantly expand the range of applications of core@shell structures. Tetraethoxysilane (TEOS) is usually used as a precursor for silica shells. In this case, it is also necessary to use a surfactant to obtain a mesoporous shell having a higher loading capacity.

This work aims to study the possibility of using another precursor – 3-mercaptopropyltrimethoxysilane (MPTMS) which has several advantages over TEOS. First, the thiol group has a chemical affinity for the surface of gold nanorods. Second, the asymmetric structure of the MPTMS molecule provides the formation of a porous shell without the use of surfactant. Also, it should be noted that the presence of the SH-group in the shell can facilitate its loading with the targeted compounds. For example, it is well known that thiol groups coordinate the ions of different metals. In this study, we demonstrate the advantages of SiO<sub>1.5</sub>SH-shells by loading with platinum-based drug – cisplatin.

Gold nanorods were obtained by the seedless method in micellar solutions of cetyltrimethylammonium bromide [1]. The synthesis of the organosilica shell was carried out in an alkaline medium. Note that the condensation of organosilica species can occur not only on the gold nanorod surface but also in the bulk of the solution, which leads to the formation of such by-products as coreless organosilica nanoparticles. Such by-products are a common problem of silica shell synthesis on the nanoparticle surface. To solve this problem, it is necessary to suppress homogeneous nucleation. We succeeded in achieving this aim by drop-wise injection MPTMS, and by increasing the concentration of gold nanorods and the amount of ethanol in the reaction system. Moreover, the synthesis was carried out at an elevated temperature (40–60°C). The optimized protocol allows us not only to completely suppress the formation of organosilica nanoparticles but also to provide fine control of the SiO<sub>1.5</sub>SH-shell thickness of composite nanoparticles (Figure 1).



**Figure 1.** Transmission electron microscopy images of gold nanorods coated SiO<sub>1.5</sub>-shell with thickness 13 nm (a) and 28 nm (b).

Data of cisplatin sorption by SiO<sub>1.5</sub>SH-shells of composite nanoparticles were obtained. We should note that the sorption value is high enough (greater than 1 g/cm<sup>3</sup>). The loading of cisplatin into SiO<sub>1.5</sub>SH-shells is confirmed by elemental mapping by energy dispersive analysis of X-rays. Besides the expected elements like Au, S, Si, the Pt is also detected in a rather high quantity. The assumption that thiol groups are responsive to the high sorption value of cisplatin is confirmed by the data of FTIR spectroscopy. The band near 2560 cm<sup>-1</sup>, corresponding to the stretching vibrations of the SH-group, disappears after the sorption of cisplatin.

## References

[1] Salavatov N.A., Dement'eva O.V., Mikhailichenko A.I., Rudoy V.M., *Colloid J.* **2018**, 80, 541–549.

Acknowledgements. This work was supported by the Russian Foundation for Basic Research (project No 20-33-90266).

# INFLUENCE OF PLASMA PARAMETERS ON THE SIZE AND MORPHOLOGICAL CHARACTERISTICS OF DEPOSITED ZINC OXIDE NANOPARTICLES

*Sazanova T.S.*<sup>1</sup>, *Mochalov L.A.*<sup>1</sup>, *Logunov A.A.*<sup>1</sup>, *Kudryashov M.A.*<sup>1</sup>, *Fukina D.G.*<sup>2</sup>, *Yunin P.A.*<sup>3</sup>, *Vorotyntsev I.V.*<sup>1,4</sup>

<sup>1</sup> Nizhny Novgorod State Technical University n.a. R.E. Alekseev, Nizhny Novgorod, Russia

<sup>2</sup> Lobachevsky State University of Nizhny Novgorod, Nizhny Novgorod, Russia

<sup>3</sup> Institute for Physics of Microstructures RAS, Nizhny Novgorod, Russia

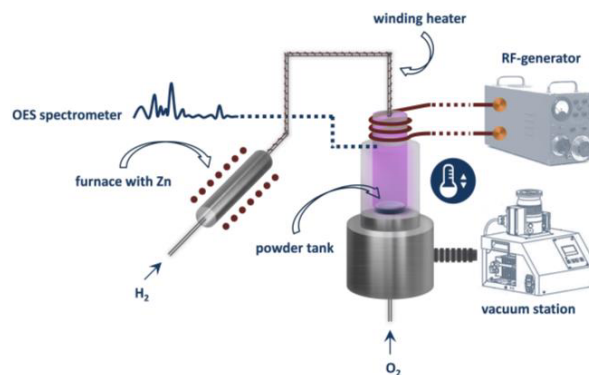
<sup>4</sup> Mendeleev University of Chemical Technology of Russia, Moscow, Russia

Young Scientist

[yarymova.tatyana@yandex.ru](mailto:yarymova.tatyana@yandex.ru)

Zinc oxide is one of the most important materials of our time. Zinc oxide is widely used in electronics as a material for solar cells, fluorescent devices, backup power supplies, fuel cells, components of artificial intelligence systems, and various types of sensors. Zinc oxide is also a promising material for use in membrane gas separation technologies as a filler for polymeric membranes with a mixed matrix for removing carbon dioxide from natural and flue gases. One of the most promising methods for producing zinc oxide nanoparticles with different sizes and morphologies is plasma-enhanced chemical vapor deposition (PECVD). This method allows for versatility, controllability, one-stage, high purity of the final material, cost efficiency, and scalability [1-3]. Nevertheless, for the widespread use of the PECVD method to obtain nanosized zinc oxide with variable morphology, it is necessary to carry out fundamental studies of the process parameters' influence on the final product.

In the current work, a direct one-stage synthesis of zinc oxide nanoparticles by the PECVD method (Fig. 1) from elemental high-purity zinc in a zinc-oxygen-hydrogen plasma-forming mixture (with control of its composition by optical emission spectroscopy) was carried out with varying deposition parameters: energy input (plasma discharge power), a zinc source temperature, and a reactor temperature in the deposition zone. The size and morphological parameters of the obtained zinc oxide powders, their stoichiometric and chemical composition, as well as structural properties and homogeneity were studied. The study used methods such as scanning electron and atomic force microscopy, energy dispersive X-ray spectroscopy, X-ray structural analysis and Raman spectroscopy, as well as statistical methods for processing and analyzing experimental data.



**Figure 1.** The scheme of a plasma-chemical installation with a pear-shaped reactor.

It was established that to obtain zinc oxide nanoparticles with specified size and morphological characteristics by plasma-chemical synthesis, it is necessary: (1) increasing the zinc source temperature to obtain more elongated structures in one direction (and vice versa); (2) increasing the plasma discharge power to reduce the transverse dimensions of the deposited structures (and vice versa); (3) decreasing the reactor temperature in the deposition zone to reduce the transverse dimensions of the deposited structures (and vice versa), however, taking into account that at relatively low temperatures instead of powder structures, film ones can form.

## References

- [1] Mochalov L., Logunov A., Vorotyntsev V. *Mater. Res. Express* **2019**, 6, 056407
- [2] Mochalov L., Logunov A., Markin A., Kitnis A., Vorotyntsev V. *Opt. Quantum Electron.* **2020**, 52, 197
- [3] Mochalov L., [et al.] *Plasma Chem. Plasma Process.* **2021**, 41, 493-506

Acknowledgments. The SEM and Raman spectroscopy studies were performed by the Collective Usage Center "New Materials and Resource-saving Technologies" (Lobachevsky State University of Nizhny Novgorod). This work was supported by the Russian Science Foundation (grant no. 20-79-00138).

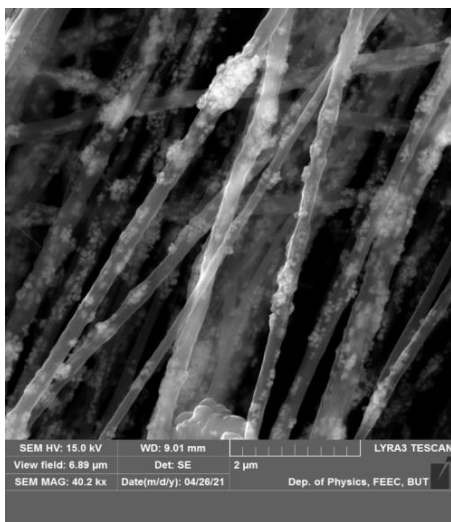
# ENHANCED PIEZOPHOTOCATALYTIC DECOMPOSITION OF METHYLENE BLUE BY $\alpha$ -Fe<sub>2</sub>O<sub>3</sub> CONTAINING PVDF NANOFIBERS

*Selimov D.A.<sup>1</sup>, Gulakhmedov R.R.<sup>1</sup>, Abdurakhmanov M.G.<sup>1</sup>, Shuaibov A.O.<sup>1</sup>, Kadiev M.V.<sup>1</sup>, Orudzhev F.F.<sup>1</sup>, Ramazanov Sh.M.<sup>1</sup>, Sobola D.S.<sup>1</sup>*

<sup>1</sup>Dagestan State University, Makhachkala, Russia

Student

[ff.orudzhev@dgu.ru](mailto:ff.orudzhev@dgu.ru)



**Figure 1.** SEM images of  $\alpha$ -Fe<sub>2</sub>O<sub>3</sub> containing PVDF nanofibers film

there are certain areas in which  $\alpha$ -Fe<sub>2</sub>O<sub>3</sub> nanoparticles are attached to the outside of nanowires. This fixing will limit the loss and entrainment of the photocatalyst. The study of the structure by XRD, Raman, XPS, FTIR methods showed that the addition of  $\alpha$ -Fe<sub>2</sub>O<sub>3</sub> promotes an increase in the proportion of the electroactive phase of PVDF.

The process of piezocatalytic and piezophotocatalytic oxidation of methylene blue (MB) was investigated. Mechanical stress was created using ultrasound (frequency 18 kHz, 250 W). The source of UV-Visible light was a high-pressure mercury arc lamp. Since it is known that MB can be degraded directly by photolysis and sonolysis, these studies were also carried out to distinguish between the effects. The data are presented in figure 2.

The results show that during piezophotocatalysis, the efficiency of MB decomposition increases significantly. The solution is almost completely discolored in 60 minutes.

This behavior indicates that, under the action of light and ultrasound, piezoelectric films can generate more photogenerated carriers, which ultimately leads to an increase in photocatalytic activity.

## References

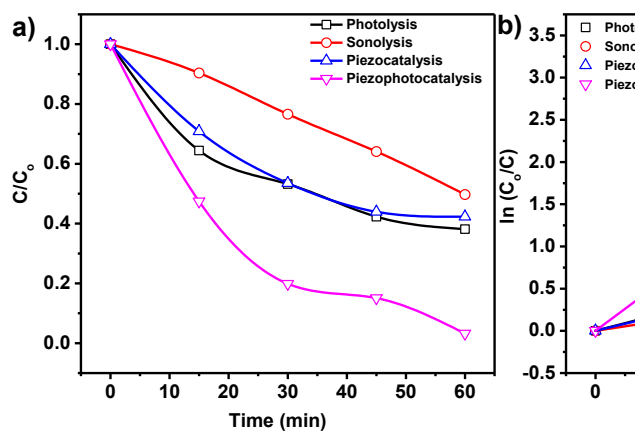
- [1] Tu S., Guo Y., Zhang Y., Hu C., Zhang T., Ma T., Huang H. *Advanced Functional Materials*, **2020**, 30 (48), 2005158.
- [2] Kaspar P., Sobola D., Částková K., Knápek A., Burda D., Orudzhev F., Hadaš Z. *Polymers*, **2020**, 12(12), 2766.

The use of the piezoelectrochemical effect in photocatalysis is a new tool that provides a more efficient separation of photoinduced charges due to the generation of an internal electric field under the action of mechanical stress. In recent years, various piezoelectric materials such as ZnO, MoS<sub>2</sub>, Pb(Zr<sub>0.52</sub>Ti<sub>0.48</sub>)O<sub>3</sub>, MoS<sub>2</sub>, NaNbO<sub>3</sub> and BaTiO<sub>3</sub> have been widely studied as piezocatalysts for water splitting and decomposing of organic pollutants [1].

However, the search for more efficient, environmentally friendly, biocompatible and easy-to-use materials is still relevant.

In this regard, in our study, we synthesized a composite organic-inorganic film that combines the piezoelectric properties of polyvinylidene fluoride (PVDF) and the photocatalytic properties of iron oxide ( $\alpha$ -Fe<sub>2</sub>O<sub>3</sub>).

Figure 1 shows an SEM image of PVDF nanowires with iron oxide, obtained by electrospinning according to the method described in our work [2]. The thickness of the resulting film was 25  $\mu$ m. The diameter of nanowires varies from 200 to 400 nm. It can be seen that  $\alpha$ -Fe<sub>2</sub>O<sub>3</sub> nanoparticles are rather uniformly incorporated into the inner cavities of nanowires. In addition,



**Figure 2.** The MB (C=1 mg/l) degradation curves. V = 20 ml, S = 3 cm<sup>2</sup>

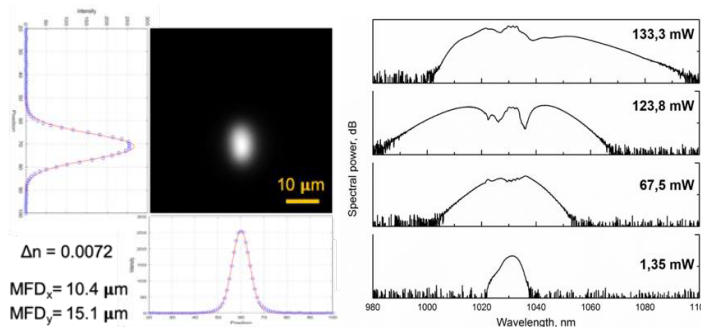
# DIRECT LASER WRITING OF OPTICAL WAVEGUIDES WITH PRECIPITATED SILVER NANOPARTICLES IN ZINC PHOSPHATE GLASS

*Shakhgildyan G.Yu.<sup>1</sup>, Lipatiev A.S.<sup>1</sup>, Fedotov S.S.<sup>1</sup>, Vetchinnikov M.P.<sup>1</sup>, Lotarev S.V.<sup>1</sup>, Sigaev V.N.<sup>1</sup>*

<sup>1</sup>Mendeleev University of Chemical Technology of Russia, Moscow, Russia  
Young Scientist

[georgiy.shahgildyan@gmail.com](mailto:georgiy.shahgildyan@gmail.com)

Fabrication of 3D waveguides in different optical materials by the direct laser writing (DLW) technique is widely applied due to the high precision, speed, and versatility of the process [1]. Unlike typical materials i.e. commercially available optical glasses or crystals, laser writing in materials with unusual compositions (for example glasses doped with noble metals or composition close to the stoichiometry of the crystals) could provide a combination of the linear and nonlinear optical properties which appear in the laser-modified zones [2,3]. In this work, we present the results on the DLW of nonlinear optical waveguides in zinc phosphate glass containing silver and show that fabricated waveguides could be used for the supercontinuum generation (SC) of light in the near-IR range. Glass was synthesized using the convenient melt-quenching technique described earlier [2]. Waveguides were written using the single pass of the tightly focused laser beam emitted by the regeneratively amplified Yb:KGW femtosecond laser system Pharos SP (Light Conversion Ltd.) operating at a wavelength  $\lambda = 1030 \pm 2$  nm. The laser pulse duration was 180 fs, the applied pulse repetition rate was 1 MHz, pulse energy was 50 nJ and scanning speed was varied in the 0.5-5  $\mu\text{m/s}$  range. Waveguiding properties of the written waveguides were characterized after the coupling of the focused CW laser beam at 1550 nm or the femtosecond laser beam at 1030 nm.



**Figure 1.** a) Near-field profile at 1550 nm from the output of the waveguide written at 50 nJ pulse energy, 2  $\mu\text{m/s}$  speed and 1 MHz pulse repetition rate; b) Spectra of light collected from the output of the laser-written waveguide coupled with 1030 nm femtosecond laser pulses.

Using the quantitative phase microscopy and QPm software we estimated that the value of the refractive index change ( $\Delta n$ ) of the written waveguides decreases in the  $(14.5-4.0) \cdot 10^{-3}$  range with the change of the writing speed from 0.1 to 5  $\mu\text{m/s}$ . Confocal absorption and photoluminescence spectra recorded from the laser-written zones, together with the electron microscopy data indicated that plasmonic silver nanoparticles, as well as silver clusters, were precipitated in the lateral parts of the waveguides during the DLW. A near-field profile collected from the output of the waveguide written at 2  $\mu\text{m/s}$  scanning speed is presented in Fig. 1 (a). One can see the single-mode behavior of the guided beam. Propagation losses of the waveguide were estimated by the interference method as low as  $1.55 \pm 0.15$  dB/cm. The coupling of the focused 1030 nm femtosecond laser beam in the waveguides also showed their good light-propagation ability, however, we observed only the multimode behavior for all written waveguides. The spectrum of the light after the propagation through the waveguides was significantly broadened indicating the SC generation in the written waveguides. With the increase of the laser pump power up to the value near the breakdown threshold of 133.3 mW, 82 nm spectral broadening was achieved (Fig. 1b). The observed SC generation can be due to self-phase modulation of the light occurring under the influence of plasmon enhancement by the silver nanoparticles precipitated in the waveguide [4].

## References

- [1] Choi J., Schwarz C. *Int. J. Appl. Glass Sci.* **2020**, 11(3), 480-490.
- [2] Shakhgildyan G.Yu., et al. *J Non Cryst Solids.* **2020**, 481, 634-642.
- [3] Lipatiev A.S., et al. *Cryst. Growth Des.* **2017**, 17(9), 4670-4675.
- [4] Driben R., Husakou A., Herrmann J. *Opt. Express.* **2009**, 17(20), 17989-17995.

Acknowledgements. This work was supported by the Council for grants of President of Russia (grant MK-1194.2020.3).

# DETONATION NANODIAMOND DEAGGLOMERATION IN SONICATION ASSISTED ADVANCED OXIDATION PROCESS

Shestakov M.S.<sup>1</sup>, Shvidchenko A.V.<sup>1</sup>, Yudina E.B.<sup>1</sup>, Besedina N.A.<sup>2</sup>, Koniakhin S.V.<sup>2,3</sup>,  
Kirilenko D.A.<sup>1</sup>, Dideikin A.T.<sup>1</sup>

<sup>1</sup> Ioffe Institute, Saint-Petersburg, Russia

<sup>2</sup> Alferov University, Saint-Petersburg, Russia

<sup>3</sup> Institut Pascal, PHOTON-N2, Université Clermont Auvergne, CNRS, SIGMA Clermont,  
Institut Pascal, F-63000 Clermont-Ferrand, France

Junior Researcher

mikhail.shestakov@gmail.com

DND (detonation nanodiamond) is a commercially available synthetic nanodiamond with crystal size about 5 nm obtained by detonation of explosives. A strong agglomeration of DND particles is a crucial issue for wide area of modern potential applications. A number of methods for DND deagglomeration has been developed and summarized in a recently published model of DND agglomerate. The agglomerate model states that individual DND particles are covalently bound together in edge-to-surface and vertex-to-surface manner [1]. Among other, the model implies that a preliminary thermal annealing is an essential step for efficient DND deagglomeration due to sp<sup>3</sup>-sp<sup>2</sup> rehybridization of contact areas and subsequent weakening of interparticle bonding.

Advanced oxidation processes (AOPs) are set of oxidative chemical modification methods based on reactions with hydroxyl radical ( $\cdot\text{OH}$ ). Recently, advanced oxidation process was implemented for surface chemical modification of individual DND particles in already deagglomerated DND hydrosols [2]. Currently, a new approach to DND deagglomeration is proposed [3].

DND agglomerates of the size from 20 to 200 nm were exposed to oxidative treatment in with ozone under UV irradiation in water media (Advanced Oxidation Process). Subsequent sonication and centrifugation gave a stable hydrosol of individual DND particles with negative zeta potential of  $-65$  mV. Successful deagglomeration of DND particles confirmed by DLS measurement of particle size distribution and direct TEM observations. The yield of the desired 4 – 5 nm fraction of individual DND particles reached 33 wt.%. XRD showed no signs of DND crystalline core degradation. According to the FTIR data, the surface of DND particles was enriched with carboxyl functional groups. Moreover, an impact of individual components of Ozone/UV/US advanced oxidation system on DND deagglomeration efficiency was studied.

The approach provides relatively high yield of deagglomerated detonation nanodiamond without impact of high temperatures on the DND particles. That could be useful in some applications, exploiting defects of DND crystalline core. Also, the approach allows avoiding gas phase processes specific to other deagglomeration methods. Sticking to wet-chemistry only could be useful for process scalability.

The investigation of impact of individual components of Ozone/UV/US advanced oxidation system on DND deagglomeration efficiency showed that UV irradiation stimulated decomposition of ozone in water media with formation of hydroxyl radical is crucial for DND deagglomeration, while simultaneous ultrasonication increases the yield of 4 – 5 nm fraction of individual DND particles. The other combinations of components are ineffective for DND deagglomeration.

The model of DND deagglomeration is also refined. Apparently, hydroxyl radicals generated during AOP treatment are able to cause interparticle bonds cleavage and that weakens interparticle attachment and promote agglomerate disintegration in subsequent ultrasonication treatment.

## References

- [1] Dideikin A.T., Aleksenskii A.E., Baidakova M.V., Brunkov P.N., Brzhezinskaya M., Davydov V.Y., Levitskii V.S., Kidalov S.V., Kukushkina Y.A., Kirilenko D.A., Shnitov V.V., Shvidchenko A.V., Senkovskiy B.V., Shestakov M.S., Vul' A. Ya. *Carbon* **2017**, *122*, 737–745. DOI:10.1016/j.carbon.2017.07.013.
- [2] Shestakov M.S., Vul S.P., Dideikin A.T., Larionova T.V., Shvidchenko A.V., Yudina E.B.; Shnitov V.V. *J. Phys. Conf. Ser.* **2019**, *1400*, 055044. DOI:10.1088/1742-6596/1400/5/055044.
- [3] Shestakov M.S., Shvidchenko A.V., Yudina E.B., Besedina N.A., Koniakhin S.V., Kirilenko D.A., Dideikin A.T. *Fullerenes Nanotub. Carbon Nanostruct.* **2021**, *In press*, DOI: 10.1080/1536383X.2021.1935887

Acknowledgements. This work was supported by the Russian Foundation for Basic Research (project No 18-29-19125 MK)



# A SIMPLE ROUTE FOR CREATING SMART MESOPOROUS SILICA VEHICLES LOADED WITH TWO POORLY WATER-SOLUBLE DRUGS

*Shishmakova E.M.<sup>1</sup>, Dement'eva O.V.<sup>1</sup>, Naumova K.A.<sup>1</sup>, Rudoy V.M.<sup>1</sup>*

<sup>1</sup>Frumkin Institute of Physical Chemistry and Electrochemistry RAS, Moscow, Russia  
PhD student

[alena\\_shishmakova@mail.ru](mailto:alena_shishmakova@mail.ru)

The encapsulation of functional compounds of different nature, in particular drugs with low solubility in water, is a very relevant problem nowadays. The providing of targeted delivery of such compounds and their controlled release in the body are of significant interest in terms of biomedical applications. Mesoporous silica nanocontainers (MSNs) characterized by low toxicity, high specific area, and ordered pore system can be used as promising drug carriers [1].

The classical method for MSNs production is a sol–gel synthesis using the templates from the micelles of inert surfactants, which are eliminated from the particles after their formation. The subsequent loading of the drug into the porous silica particles occurs by its sorption from the solution. This route has some disadvantages, namely the low capacity of such structures and the difficulty of controlling the release of the target substance into the environment. Recently [2] we have demonstrated a new approach, which consists in combining the stages of MSNs synthesis and their loading with a functional compound, the micelles of which serve as a template. The suggested one-pot method allows to significantly increase the MSNs loading capacity, as well as to obtain multifunctional structures containing two or more biologically active compounds.

Thus, we have shown the principal possibility of MSNs synthesis using the micelles of the amphiphilic antiseptic miramistin with a solubilized hydrophobic natural compound curcumin, which has a wide spectrum of pharmacological action [3]. This work aims to continue these experiments and to obtain information on the effect of the synthesis conditions on particle structure and loading capacity, as well as to study the release rate of the targeted compounds and reveal the factors that control this process.

The influence of the synthesis conditions on the morphology of MSNs was studied. It is shown that spherical and prolonged particles are formed in a neutral and alkaline medium, correspondingly. The obtained particles are characterized by an ordered porous structure and contain a significant amount of encapsulated compounds (1 g of drugs per 1 g of SiO<sub>2</sub> or more). Moreover, the possibility for the formation of a shell from the biocompatible polymer (polydopamine) on the surface of MSNs was shown and the optimal conditions of this process were determined.

The possibility to control the drug's release rate from such MSNs into a dispersion medium with a different pH is demonstrated. The rate of this process increases with a decrease in pH of the dispersion medium. It is shown that the modification of the MSNs surface with the polydopamine allows a more subtle control of encapsulated compounds release. Moreover, additional opportunities arise due to the ability of this polymer to absorb near-IR radiation.

Such multifunctional MSNs can be used to create new drug forms of curcumin that provide its high solubility in water, targeted delivery, and controlled release. The combined effect of the two antiseptic drugs, along with the polymer coating of MSNs, indicates the prospects for the use of such particles in biomedicine. The suggested approach can be applied to a wide range of hydrophobic substances.

## References

- [1] Argyo C., Weiss V., Brauchle C., Bein T. *Chem. Mater.* **2014**, 26, 435–451.
- [2] Dement'eva O.V., Vinogradova M.M., Frolova L.V., Ogarev V.A., Kuznetsov U. I., Rudoy V.M. *Colloid J.* **2014**, 76, 22–27.
- [3] Naumova K.A., Dement'eva O.V., Zaitseva A.V., Rudoy V.M. *Colloid J.* **2019**, 81, 478–486.

Acknowledgements. This work was supported by the Russian Foundation for Basic Research (project No 19-03-00703).

# CRYOCHEMICAL SYNTHESIS OF MAGNETITE AND MAGHEMITE NANOPARTICLES AND THEIR HYBRID COMPOSITES WITH DIOXIDINE

*Shumilkin A.S.<sup>1</sup>, Vernaya O.I.<sup>1</sup>, Semenov A.M.<sup>2</sup>, Shabatina T.I.<sup>1</sup>*

<sup>1</sup>Lomonosov Moscow State University, Department of Chemistry, Moscow, Russia

<sup>2</sup>Lomonosov Moscow State University, Department of Biology, Moscow, Russia  
Student, 4th year specialist

[alexpard99@gmail.com](mailto:alexpard99@gmail.com)

Nanoparticles of magnetite and its oxidized form maghemite have properties characteristic of all nanomaterials, such as a large specific surface area and a high proportion of surface atoms with uncompensated bonds. In addition, they exhibit superparamagnetic properties that occur below a size value of about 128 nm. At this moment, the particles pass into a single-domain state and become uniformly magnetized throughout the volume. The unique properties of superparamagnetic iron oxides allow them to be used in a wide range of fields: from magnetic storage media to magnetic bioseparation systems. Magnetite and maghemite nanoparticles have great potential in medicine due to their high biocompatibility and low toxicity. They are considered as promising agents for magnetic resonance imaging and magnetic hyperthermia; they can be also used as magnetic vectors in targeted drug delivery systems, including antibacterial ones.

In the work, low-temperature technologies were used to obtain nanoparticles of superparamagnetic iron oxides and their hybrid systems with the antibacterial drug dioxidine. One of the most widespread methods of obtaining magnetite nanoparticles is the coprecipitation method: soluble salts of ferrous and trivalent iron in a molar ratio of 1:2 are coprecipitated in an aqueous solution with alkali or ammonia. In our case, we carried out the deposition of iron ions at -20° C from the surface of cryoagranules, which made it possible to reduce the average size of the resulting particles from 12 to 5 nm.

To obtain maghemite nanoparticles, thermal decomposition of cryochemically modified (micronized) iron acetylacetonate was used. This method makes it possible to obtain maghemite particles with a size of 40-150 nm without using toxic reagents and solvents. To characterize the obtained magnetic nanoparticles and precursors, the methods of XRD, IR spectroscopy, TEM, TG, and DSC were used.

Cryochemical synthesis of hybrid systems of the antibacterial drug dioxidine with magnetite and maghemite nanoparticles was carried out. The resulting systems represent (according to TEM, SEM micrographs, IR-, UV-spectroscopy and X-ray phase analysis data) a drug particles with a size of 50-100 nm inside and on the surface of which magnetite or maghemite particles are located. The size of the superparamagnetic particles in the composition of hybrid composites is determined by the particle size of the used precursor powder.

The disk diffusion method was used to characterize the antibacterial activity of the obtained systems against *E. coli*, which turned out to be higher than the antibacterial activity of their constituent components.

Acknowledgements. This work was supported by the Russian Science Foundation, grant from the Russian Science Foundation No. 16-13-10365-P.

# SALTS SELF-ORGANIZATION OF ALKALINE EARTH ELEMENTS AND FATTY ACIDS ON THE SURFACE OF THE AQUEOUS SUBPHASE

*Silyavka E.S.*<sup>1</sup>, *Selytin A.A.*<sup>1</sup>, *Podolskaya E.P.*<sup>2,3</sup>

<sup>1</sup>Saint Petersburg State University, Saint Petersburg, Russia

<sup>2</sup>Institute for Analytical Instrumentation of the Russian Academy of Sciences, Saint Petersburg, Russia

<sup>3</sup>Institute of Toxicology, Federal Medico-Biological Agency, Saint Petersburg, Russia

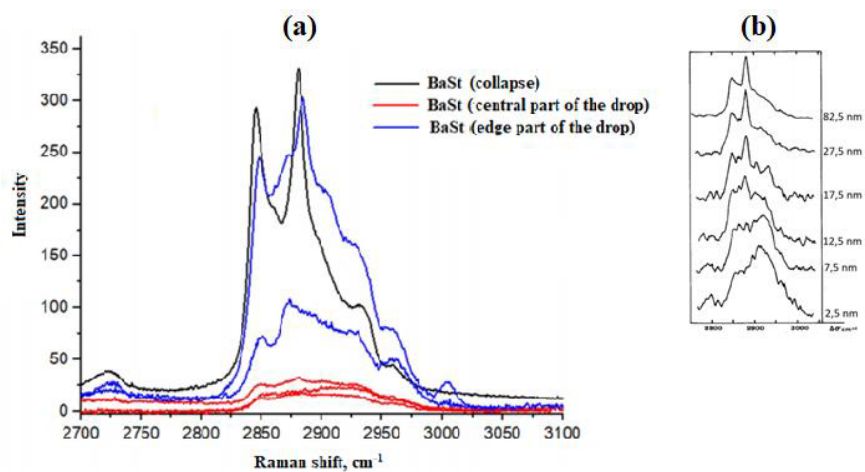
PhD Student

[lenasil1@mail.ru](mailto:lenasil1@mail.ru)

In recent years, the researcher's interest in the electronic properties of thin films containing metal atoms [1] has not diminished. However, the procedure for obtaining and transferring such nanostructures by the classical method using a Langmuir bath is very laborious. That is why we made the assumption that a monolayer can be obtained in a drop geometry directly on a substrate without additional transfer.

The film formation on the droplet surface by the proposed method was showed using LDI analysis.

The mechanism of the film formation on the droplet surface was investigated with optical microscopy. Also, the contact angles of the film formation process were determined. It was found that this formation occurs on the surface of the aqueous subphase, as well as during the films production using a Langmuir bath.



**Figure 1.** Raman spectra (a) Experimental data (b) Literature data [2].

According to our proposed method was established using Raman spectroscopy that in the end the collapsed monolayers are obtained (fig.1).

## References

- [1] Ishihara K. M., Tian F. *Langmuir* **2018**, 34(51),15689-15699
- [2] Harrand M. *The Journal of chemical physics* **1987**, 87 (9), 5176-5185

Acknowledgements. This work was supported by Russian Foundation for Basic Research (project No. 20-016-00160). The scientific research was performed at the Research park of St.Petersburg State University

# INVESTIGATION OF THE SORPTION CHARACTERISTICS OF A NEW BIOMATERIAL IN RELATION TO ORGANIC SUBSTANCES AND OIL PRODUCTS

*Sitko A.V., Mashukova Yu.A., Ponomareva M.A., Cheremisina O.V.*

Saint Petersburg Mining University, Saint Petersburg, Russia  
Student

[aleksandr.sitko113@yandex.ru](mailto:aleksandr.sitko113@yandex.ru)

Nowadays, in order to reduce the negative impact on the environment of chemical and other industrial production, an urgent task is to reduce the content of ketones, aldehydes, phenols, benzene and oil products to the values of the MPC standards in wastewater. The main method, which is applicable for solving this problem, can be the use of sorption on various activated carbons and carbons of biological origin [1] - [2]. Coal of biological origin based on poultry production waste, obtained by thermal gasification of dried chicken droppings in an oxygen environment, can act as a promising sorption material [3].

In this work, studies of the sorption and thermodynamic properties of organic material of biological origin obtained from poultry farm waste were carried out, the values of the specific surface area, porosity, mass fraction of moisture, the values of true and bulk density were determined, the chemical, elemental, fractional (granulometric) and phase composition were determined. Based on the data obtained, it was concluded that the use of a new organic material of biological origin based on poultry waste as a sorbent for purifying wastewater from ketones, aldehydes, phenols and oil products is promising. As a result of the research, the optimal pH value was obtained, which is not less than 2, which is due to the fact that at lower values the material (biochar) is destroyed.

Before carrying out sorption studies, biochar was washed with distilled water to the value of the neutral medium of the washing solution. As a result of the study of the new sorbent (fraction > 1 mm), its specific surface was  $49.76 \pm 2.49$  m<sup>2</sup>/g. The porosity value was  $18.03 \pm 0.90$  Å. The mass fraction of moisture was 3.5%. The true density value was 2.007 g / cm<sup>3</sup>, and the bulk density value was 703.786 kg/m<sup>3</sup>. According to the granulometric (fractional) composition, it was found that the sample is dominated by small and medium particles with a particle size of 2 to 0.25 mm (washed material). As a result of the chemical and elemental composition, it was revealed that the amount of total carbon in the sample was 26.5% and inorganic carbon 3.54%. Phase analysis showed that the main crystalline phases in the composition of organic material are CaCO<sub>3</sub>, KCl, Ca<sub>3</sub>(PO<sub>4</sub>)<sub>2</sub>.

As a result of studying the process of sorption of acetone and phenol under dynamic conditions (S:L = 50, pH≈7, contact time 1 hour, elution rate 0.5 rpm, fraction > 1 mm), the following thermodynamic and sorption characteristics were obtained: limiting sorption =  $123.10 \pm 6.16$  g/kg for acetone, =  $12.23 \pm 0.61$  g/kg for phenol, and for benzene =  $14.02 \pm 0.70$  g/kg.

Sorption studies of AI-92 gasoline produced by British Petroleum and diesel fuel produced by British Petroleum were carried out under dynamic conditions (S:L = 1:20, 1:50, 1:100, 1:150, 1:200, elution rate 120 rpm, contact time 10-15 min, fraction > 1 mm). The FDC value was  $10.79 \pm 0.54$  g/kg for gasoline and  $58.96 \pm 2.95$  g/kg for diesel fuel. The lower FDC value relative to the static capacity at S:L = 1:100, equal to  $129.28 \pm 6.46$  g/kg, is explained by the high volatility of gasoline and weight loss after drying. The underestimated value of the dynamic capacity relative to the static capacity at S:L = 1:100, equal to  $137.68 \pm 6.88$  g/kg, is explained by the volatility of the volatile components of diesel fuel when drying organic material after sorption. Sorption studies of Shell Helix Ultra 0W-40 engine oil were also carried out in dynamic mode. The FDC value was  $208.37 \pm 10.42$  g/kg. The studies of the sorption of fuel oil (LLC "Kirishinefteorgsintez") were carried out under static conditions. The static capacity value was  $635.25 \pm 31.76$  g/kg.

## References

- [1] Gao J., Liu Y., Li X., Yang M., Wang J., Chen Y. A promising and cost-effective biochar adsorbent derived from jujube pit for the removal of Pb (II) from aqueous solution// Scientific Reports. – 2020. – Vol. 10. – № 1. – Number of the article 7473.
- [2] Teng D., Zhang B., Xu G., Wang B., Mao K., Wang J., Sun J., Feng X., Yang Z., Zhang H. Efficient removal of Cd (II) from aqueous solution by pinecone biochar: Sorption performance and governing mechanisms// Environmental Pollution. – 2020. – Vol. 265. – Number of the article 115001.
- [3] Batool S., Idrees M., Hussain Q., Kong J. Adsorption of copper (II) by using derived-farmyard and poultry manure biochars: Efficiency and mechanism// Chemical Physics Letters. – 2017. – Vol. 689. – P. 190-198

# INTERCALATION OF PORPHYRIN-BASED METAL-ORGANIC FRAMEWORK IN LAYERED EUROPIUM HYDROXIDE: A SYMBIOMETIC HYBRID MATERIAL

*Sokolov M.R.<sup>1,2</sup>, Enakieva Y.Y.<sup>1</sup>, Yapryntsev A.D.<sup>3</sup>, Shiryayev A.A.<sup>1</sup>, Zvyagina A.I.<sup>1</sup>, Kalinina M.A.<sup>1</sup>*

<sup>1</sup>A.N. Frumkin IPCE RAS, Moscow, Russia

<sup>2</sup>Moscow State University, Moscow, Russia

<sup>3</sup>N.S. Kurnakov IGIC RAS, Moscow, Russia

Student

[sokolmax495@gmail.com](mailto:sokolmax495@gmail.com)

Porphyrin metal-organic frameworks (MOF) are the class of coordination polymers integrating functionalized porphyrins as organic linkers and metal ions or clusters binding these linkers into the continuously ordered structure. Porphyrin MOFs are most useful for applications in separation membranes, sensors and heterogeneous catalysts. However, these materials assembled by weak coordination bonds can undergo decomposition or rearrangements in the chemically active or aggressive environment. A possible strategy for solving this problem is the assembly of MOFs on the solid surface of layered inorganic particles. This approach makes it possible to integrate the functional properties of porphyrin MOFs with those of supporting inorganic solids in a single hybrid structure. In this work we realized this idea through the intercalation of 5,10,15,20-tetrakis(4-carboxyphenyl) zinc porphyrinate (ZnTCPP) and a binuclear complex of zinc acetate as the MOF components into the layered europium (III) hydroxychloride (LEuH) as dispersed solid matrix. This compound is a layered material exhibiting anion-exchange properties and coordination and luminescent properties of europium. Intercalation of components of porphyrin MOF into the LEuH by anion-exchange mechanism makes it possible to assemble 2D-MOF in the interlayer space of LEuH, obtaining stable hybrid material with combined properties of MOF and inorganic matrix.

Zinc complexes of porphyrins show high affinity toward organic phosphates, which participate in a wide range of natural and industrial processes. Therefore, we studied the catalytic activity of the material in a course of the hydrolysis of bis(4-nitrophenyl) phosphate, which is widely used as a model reaction for DNA phosphodiesterase. The UV-vis absorption spectroscopy was used to monitor the reactions with the hybrid catalyst and the control system of pure LEuH. By studying the kinetics of the catalyzed hydrolysis, we showed that the intercalated hybrid exhibits synergetic catalytic effect on the process when compared to the activity of the non-intercalated LEuH matrix and ZnTCPP-based MOF. To investigate the origin of this synergy, we studied the changes in the structure and chemistry of the hybrid materials by using a combination of analytical techniques including Raman, FTIR and UV-vis spectroscopies and the X-ray diffraction. We also pioneered the application of MALDI-TOF spectrometry for analyzing the composition of the absorbed and transformed substances in the solid powders without decomposing its structure. These observations provided a basis for understanding the mechanism underlying the catalytic process in the hybrid system by separating the contributions of both components.

The obtained results suggest that the hybrid material showed symbiometric properties, that is, mimicking the behavior of biological symbionts, due to the mutual stabilization of the components in the reaction media. The porphyrin MOF components assembled in the interlayer space prevent splitting of the inorganic matrix in a course of the catalyzed reaction and the LEuH matrix protects the unstable MOF clusters from decomposition in the acidic solution. The symbiometric properties of the hybrid materials also demonstrate themselves in the catalytic synergy since only mutually integrated porphyrin MOF and LEuH can efficiently catalyze the hydrolysis of organic phosphates. We believe that this strategy can advance rational design of the wide range of intercalated layered materials with various synergetic functions.

**Acknowledgements.** This work was supported by supported by the Russian Foundation for Basic Research (grant 18-29-04026 MK)

# THE INFLUENCE OF PRECIPITATION PH VALUE AND TREATMENT METHOD ON ALUMINUM OXIDE SORPTION PROPERTIES

*Solodovnikova P.A.<sup>1</sup>, Mashkovtsev M.A.<sup>1</sup>*

<sup>1</sup>Ural Federal University, Ekaterinburg, Russia

Student

[sol\\_polina@e1.ru](mailto:sol_polina@e1.ru)

Aluminum oxide is a readily available mechanically strong and hydrolytically stable sorbent [1]. It is widely used in the defluorination of industrial wastewater and groundwater. One of the suitable synthesis methods for the ability to control the characteristics of aluminum oxide is the method of controlled two-jet deposition [2]. Features of the method of controlled two-stream deposition allow to influence the properties of the final product and obtain oxides with the required characteristics. One of the adjustable precipitation parameters is the pH value.

The synthesis of samples was carried out as follows: a solution of an aluminum nitrate salt and a solution of ammonia was fed in a drop mode so that the pH during the deposition was constant. Then one part of the samples was not processed, the second part of the samples was washed, the third part of the samples was washed and subjected to hydrothermal treatment. After that, all samples were dried and calcined.

The sorption properties of the samples were investigated by the potentiometric method. The optimal pH of the medium was chosen equal to 7, at which subsequent sorption experiments were carried out. The final concentration of fluorine was measured; the data obtained were used to construct sorption isotherms. The data on the sorption capacity of the samples deposited at different pH and treated by different methods are shown in Figures 1 and 2, respectively.

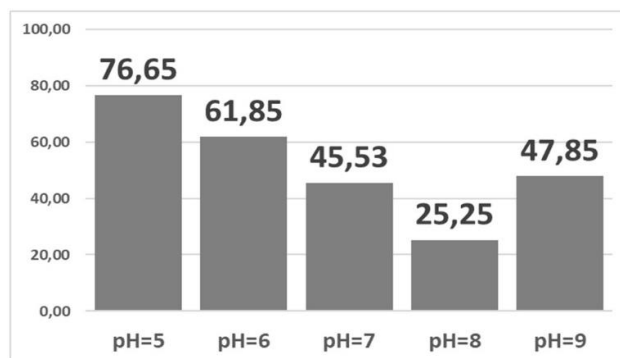


Figure 1. Sorption capacity of samples precipitated at different pH

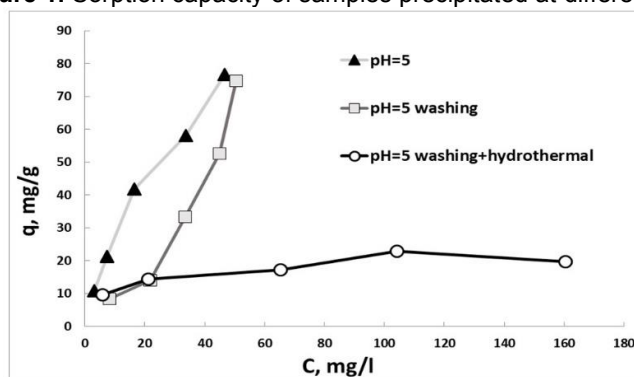


Figure 2. Sorption capacity of samples after various treatments

It was found that sample processing (washing and hydrothermal) doesn't have a significant effect on the sorption properties of aluminum oxide, slightly worsening them. But the pH value of synthesis significantly affects the physicochemical properties of samples. The sorption of fluorine is maximum for the sample precipitated at pH = 5.

## References

- [1] S.S.Tripathy, Ab. of Fluor. from Wat. Us. Mang. Diox. -coat. Act. Al., (Journ. of Haz. Mat., 2008), 153.
- [2] V.A. Dzisko and A.S. Ivanova, The main meth. for prod. Act. Alum. Ox., (SO AN USSR, 1985), M215, 110.

MODIFICATION OF OXIDIZED GRAPHENE WITH POLY(GLUTAMIC ACID)  
TO OBTAIN BIOFUNCTIONAL FILLER FOR SCAFFOLDS IN BONE TISSUE ENGINEERING

Solomakha O.A.<sup>1</sup>, Stepanova M.A.<sup>1</sup>, Averianov I.V.<sup>1</sup>, Bykovskaya M.A.<sup>2</sup>, Gofman I.V.<sup>1</sup>, Rabchinskii M.K.<sup>3</sup>,  
Ryzhkov S.A.<sup>3</sup>, Saveliev S.D.<sup>4</sup>, Korzhikova-Vlakh E.G.<sup>1</sup>

<sup>1</sup>Institute of Macromolecular Compounds of Russian Academy of Sciences, Saint Petersburg, Russia

<sup>2</sup>Saint Petersburg State Institute of Technology, Saint Petersburg, Russia

<sup>3</sup>Ioffe Institute, Saint Petersburg, Russia

<sup>4</sup>ITMO University, Saint Petersburg, Russia

PhD students

solomanya@bk.ru

Reconstruction and optimization of the healing process of bone tissue defects using new materials is an urgent task in orthopaedics and traumatology. This is due to the high level of injuries of the musculoskeletal system and the prevalence of bone diseases, which leads to catastrophic disability of the population and is accompanied by huge material costs [1].

In this regard, the biodegradable materials based on aliphatic polyesters, for example poly(lactic acid) (PLA) and polycaprolactone (PCL), are the most prospective [1]. These polymers are widely applied in medicine due to its economic availability, biocompatibility with human cells and tissues, biodegradability to non-toxic metabolites, as well as thermoplasticity, which makes it possible to obtain products by extrusion printing. However, the hydrophobic nature of aliphatic polyesters impair cell adhesion and complicates the vascularization of a polymer implant. All these disadvantages can be overcome by obtaining composite materials.

This work is devoted to the preparation of oxidized graphene (OG) particles modified by various methods to eliminate the disadvantages of PCL and the subsequent manufacture of its composite materials suitable for successful bone tissue regeneration. OG has a high mechanical strength, which may improve the mechanical parameters of polyester. To impart biofunctionality of oxidized graphene, it was modified with poly(glutamic acid) (PGlu). Glu-based peptides are known to be good calcium capturing agents that favours to the enhanced mineralization of polymeric materials and their improved integration with bone tissue [2]. In our case, it was not possible to directly covalently modify OG with poly(glutamic acid) without introducing additional spacers. In this study, methods for the modification of OG using various diamines as spacers, such as ethylenediamine and lysine, and subsequent grafting from the OG surface of PGlu were developed. All particles were studied by IR and X-ray photoelectron spectroscopy, scanning electron microscopy and thermogravimetric analysis. The hydrodynamic diameters of neat and modified OG particles as well as their zeta potentials were determined by dynamic and electrophoretic light scattering. The obtained results confirmed that both types of OG modifications have been successful. Both neat and modified OG are planned to be applied as fillers to prepare PCL-based composites as scaffolds for bone tissue.

#### References

[1] Koons G. L., Diba M., Mikos A. G. *Nature Reviews Materials*. **2020**, *5*, 584-603

[2] Stepanova M., Averianov I., Serdobintsev M., Gofman I., Blum N., Semenova N., Nashchekina Yu., Vinogradova T., Korzhikov-Vlakh V., Karttunen M., Korzhikova-Vlakh E. *Materials*. **2019**, *12*, 3435

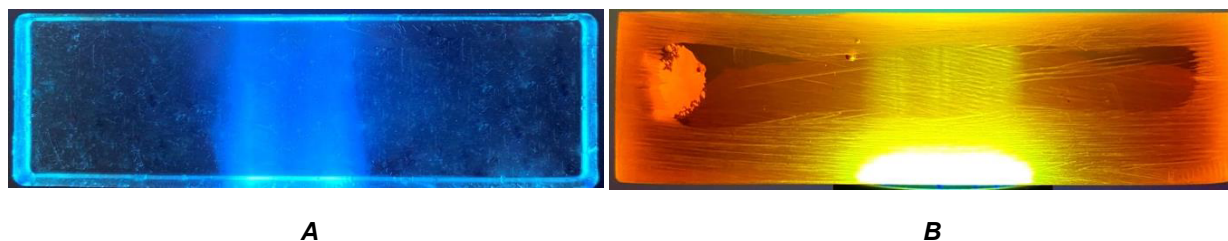
## DEVELOPMENT OF LASER-ACTIVE MEDIA CONTAINING QUANTUM DOTS

*Stepanova U.A.<sup>1</sup>, Gorbunov I.S.<sup>1</sup>, Al-Mayyahi H.A.<sup>1</sup>, Muradova A.G.<sup>1</sup>*

<sup>1</sup>*Russian University of Chemical Technology, Moscow, Russia*  
Postgraduate student  
[uljana\\_stepanova@mail.ru](mailto:uljana_stepanova@mail.ru)

Polymeric nanocomposites have various applications in science and technology, including LEDs [1], sensors [2], lasers [3], etc. Polymeric nanocomposites activated by quantum dots (QDs) are of great interest because of the unique properties of these nanocrystals. Quantum dots can fluoresce in the entire visible spectrum, moreover, they have high photostability, which makes nanocomposites based on them attractive materials for creating laser-active media [4].

Nanocomposites based on polymer matrices containing semiconductors and perovskite quantum dots were obtained in this work. Semiconducting CdSe, CdSe/CdS quantum dots were obtained by hot injection with sizes from 2.0 to 4.5 nm. The fluorescence range for these nanocrystals was 520 nm to 630 nm. Perovskite quantum dots (PQDs) of CsPbX<sub>3</sub> (X = Cl, Br, I) were obtained by hot injection with 10-12 nm sizes. The maximum in the fluorescence spectra for CsPbX<sub>3</sub> PCTs (X = Cl, Br, I) varied from 410 nm to 620 nm. Nanocomposites were prepared by direct introduction of colloidal quantum dots into the polymer matrix with the subsequent addition of a hardener. As a result, a series of nanocomposites containing different types of QDs were obtained, their optical and generative properties were studied, and a comparative analysis of nanocomposites based on semiconductor and perovskite quantum dots was given.



**Figure 1.** Polymer samples under UV irradiation: A) epoxy resin; B) epoxy-based nanocomposite containing CdSe quantum dots.

### References

- [1] Yang Y., Zheng Y., Cao W., Titov A., Hyvonen J., Manders J. R., et al. *Nat. Photon.* **2015**, 9, 259–266.
- [2] Cho H., Kwak J., Lim J., Park M., Lee D., Bae W. K., et al. *ACS Appl. Mater. Interfaces.* **2015**, 7, 10828–10833.
- [3] Supran G.J., Shirasaki Y., Song K.W., Caruge J.M., Kazlas P.T., Coe-Sullivan S., et al. *MRS Bull.* **2013**, 38, 703–711.
- [4] Antolini F., Orazi L. *Frontiers in Chemistry.* **2019**, 7.



# HYDROTHERMAL SYNTHESIS OF MnO<sub>2</sub>/CNT NANOCOMPOSITES AND INVESTIGATION OF THEIR ELECTROCHEMICAL CHARACTERISTICS

*Stolbov D.N.<sup>1,2</sup>, Ivanov A.S.<sup>1</sup>, Arkhipova E.A.<sup>1</sup>, Savilov S.V.<sup>1</sup>*

<sup>1</sup>Chemistry Department, Moscow State University, Moscow, Russia

<sup>2</sup>Ivanovo State University, Ivanovo, Russia

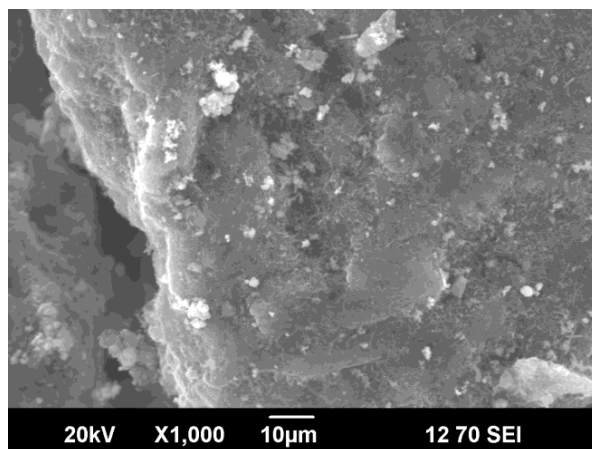
Ph.D Student

[stolbovdn@gmail.com](mailto:stolbovdn@gmail.com)

The growth in electricity consumption has provoked an urgent need in the world to develop alternative energy sources. In addition, the intermittent nature of electricity generation at solar, wind and other power plants does not allow them to be used as a permanent source of energy. As a consequence, the demands for energy storage devices such as batteries and supercapacitors will remain high. Compared with batteries, supercapacitors accumulate charge faster, have longer cycling life and comply with the Green Chemistry principles [1].

The charge accumulation in supercapacitors can be carried out both by means of a double electric layer and by means of pseudo-Faraday reactions with an active electrode material. In the case of pseudo-capacitors, the most widely used active electrode materials are oxides / hydroxides of noble and transition metals. Manganese (II) oxide has attracted a growing interest due to low cost, non-toxicity and a high theoretical specific capacity of 1370 F/g. Conductive additives such as carbon nanotubes (CNTs) are widely used to increase the conductivity of MnO<sub>2</sub> [2]. MnO<sub>2</sub> forms a variety of crystallographic structures ( $\alpha$ ,  $\beta$ ,  $\gamma$ ,  $\delta$ ). Among them, the  $\alpha$ - and  $\delta$ -MnO<sub>2</sub> types are most suitable for supercapacitors [3].

This work is devoted to the hydrothermal synthesis of MnO<sub>2</sub>/CNT nanocomposites. Temperature (120 - 160 °C), reaction time (4-24 hours) and concentration of KMnO<sub>4</sub> were varied to optimize the synthesis conditions. According to SEM (Fig. 1), MnO<sub>2</sub>/CNT nanocomposite obtained for 24 hours at 120 °C shows MnO<sub>2</sub> nanorods wrapped in CNTs. Synthesized MnO<sub>2</sub>/CNT nanocomposites were studied as an electrode material in supercapacitors.



**Figure 1.** SEM micrograph of the MnO<sub>2</sub>/CNT composite.

## References

- [1] N. Choudhary, C. Li, J. Moore, N. Nagaiah, L. Zhai, Y. Jung, J. Thomas *Adv. Mater.* **2017**, 6, 1605336
- [2] J. Wang, H. Yang, Q. Sun, C. Zhou, X. Zhang, L. Ge, X. Ma *Mater. Lett.* **2021**, 285, 129116
- [3] X. Bai, X. Tong, Y. Gao, W. Zhu, C. Fu, J. Ma, T. Tan, C. Wang, Y. Luo, H. Sun *Electrochim. Acta* **2018**, 281, 525-533

Acknowledgements. This work was supported by the Russian Science Foundation (project No проект № 21-43-00023).

# SYNTHESIS AND OPTICAL STUDY OF PLASMONIC NANOPARTICLE AGGLOMERATES WITH MODIFIERS OF CYCLE TYPE

*Strelnikov A.S., Smirnov A.N., Pyzuk A.M., Solovyeva E.V.*

Saint Petersburg State University, Saint Petersburg, Russia

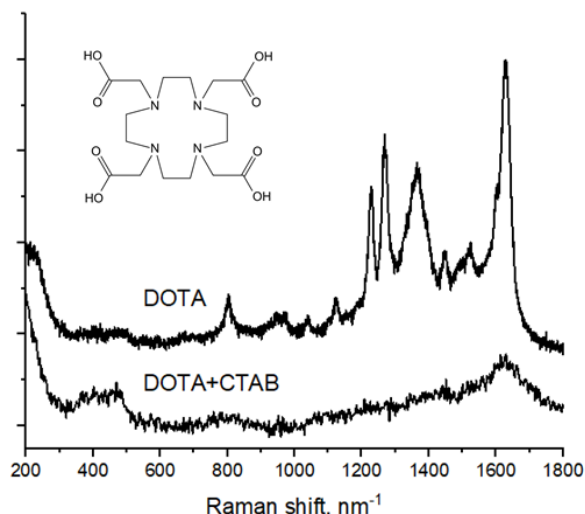
Student

alexeistrelnikov@gmail.com

Systems in which nanoparticles form agglomerates of controllable size are promising for a wide range of applications. Their synthesis and stabilization are of particular interest; first of all, a study of optical response for such systems is favorable. As previously shown [1], stilbene derivatives have proven to be efficient quasilinear "molecular linkers" for silver nanoparticles, enabling the reproducibility of the obtained nanoparticle agglomerates. In this work, we studied three molecules belonging to azamacrocycles polyfunctional ligands that can potentially exhibit the same function for gold and silver nanoparticles: cyclam (1,4,8,11-tetraazacyclotetradecane), DOTA (1,4,7,10-tetraazacyclododecane-1,4,7,10-tetraacetic acid) and HACH (hexaazatricyclo[26.2.2]tetratriaconta-13,15,28,30,31,33-hexaene). Due to cycle structure, these ligands can give another arrangement of nanoparticles and linked agglomerates with different morphology therefore.

The modification of silver and gold nanoparticles by azamacrocycles at varying synthesis parameters was carried out. The obtained systems were evaluated by transmission electron microscopy, dynamic light scattering, as well as surface-enhanced Raman spectroscopy and spectrophotometry.

The most intense SERS spectra were obtained for DOTA, which displays a nonmonotonic concentration dependence (figure 1). In the absorption spectra, in addition to the main plasmon resonance band of the particles, the appearance of a new component in the long-wave region is registered. Visual observations show the discoloration of silver and gold nanoparticle solutions in the presence of DOTA after one day. TEM images of freshly prepared solutions of the modified nanoparticles show the cross-linked nanoparticles. It is evident that cross-linking of nanoparticles by DOTA takes place but is accompanied by further aggregation. Attempt of stabilization of linked NPs with adsorbed DOTA by cetyltrimethylammonium bromide (CTAB) was made. Several stabilization schemes have led to the same result: in the presence of CTAB, SERS signal from DOTA does not arise. This suggests too strong adsorption of CTAB blocking access to the surface for azamacrocycle's molecules.



**Figure 1.** The SERS spectra of silver nanoparticles modified by DOTA with and without CTAB.

As the results revealed, azamacrocycles interact effectively with the surface of silver and gold nanoparticles, but the formed agglomerates showed low stability. Further work will be focused on a search of «soft» method for stabilization of NPs modified by azamacrocycles without losing the SERS signal from them.

## References

[1] *Coll. Surf. A* **2018**, 528, 542-548

Acknowledgements. This work was supported by the Russian Foundation for Basic Research (project No 20-33-70034). The authors thank the Resources Centers of Saint-Petersburg State University: the Interdisciplinary Center for Nanotechnology, the Center for Optical and Laser Materials Research, the Computing Centre, the Thermogravimetric and Calorimetric Research Centre.

## MESOPOROUS MAGNETICALLY SEPARABLE OXIDES IN THE SYNTHESIS OF BIOCATALYSTS BASED ON GLUCOSE OXIDASE

Sulman A.M., Grebennikova O.V., Matveeva V.G., Sulman M.G.

Tver State Technical University, Tver  
[alexsulman@mail.ru](mailto:alexsulman@mail.ru)

In recent years, many industrial processes ranging from food production to pharmaceutical synthesis have used enzymes as catalysts. The demand for enzymes in numerous catalytic processes has led to an increase in the number of studies leading to a significant improvement in the properties of enzymes. One of the widely used methods is the immobilization of enzymes, in which they are attached to a solid support, insoluble in the reaction mixture. A wide variety of materials of various origins can be used as a carrier for the immobilization of enzymes. These materials can generally be classified as organic, inorganic, and hybrid or composite. The carrier must protect the enzyme structure from the harsh reaction conditions and thus help the immobilized enzyme maintain high catalytic activity. Choosing the correct immobilization method can improve the stability of the enzyme under harsh reaction conditions, such as extreme pH, high temperatures, or the presence of organic solvents, which facilitates, among other things, the separation of the enzyme from the reaction medium. One of the promising directions in this field of biocatalysis is the use of magnetically detachable mesoporous oxides. These biocatalysts allow easy magnetic separation, energy savings, and cheaper and cleaner end products [1-2].

In this work, biocatalysts based on glucose oxidase immobilized on magnetically detachable mesoporous SiO<sub>2</sub> and Al<sub>2</sub>O<sub>3</sub> were synthesized. Detachable supports were synthesized by the formation of magnetite nanoparticles in the pores of silicon and aluminum oxides as a result of thermal decomposition of iron nitrate incorporated by impregnation. To modify the surface with functional amino groups, 3-aminopropyltriethoxysilane was used. For covalent binding of the enzyme with magnetically detachable oxides, their surface was treated with glutaric dialdehyde. The synthesized samples of biocatalysts were tested in the oxidation reaction of D-glucose to D-gluconic acid, which can be used, for example, to obtain glucono-1,5-lactone and calcium gluconate. It was found that a biocatalyst based on glucose oxidase immobilized on magnetically detachable silicon oxide exhibited greater catalytic activity (95% of the native enzyme) compared to other biocatalysts.

### References

- [1] Zdarta J. *Catalysts*. **2018**, 8, 92-98
- [2] Cowan D.A. *Enzyme Microb. Technol.* **2011**, 49, 326–346

Acknowledgements. This work was supported by the Russian Science Foundation (project No 21-19-00192).

# OPTICAL PROPERTIES AND AGGREGATIVE STABILITY OF GOLD AND SILVER NANOPARTICLES MODIFIED WITH DICARBOXYTOLANE

*Svinko V.O., Odintsova P.V., Ivanov P.V., Solovyeva E.V.*

Saint Petersburg State University, Saint Petersburg, Russia

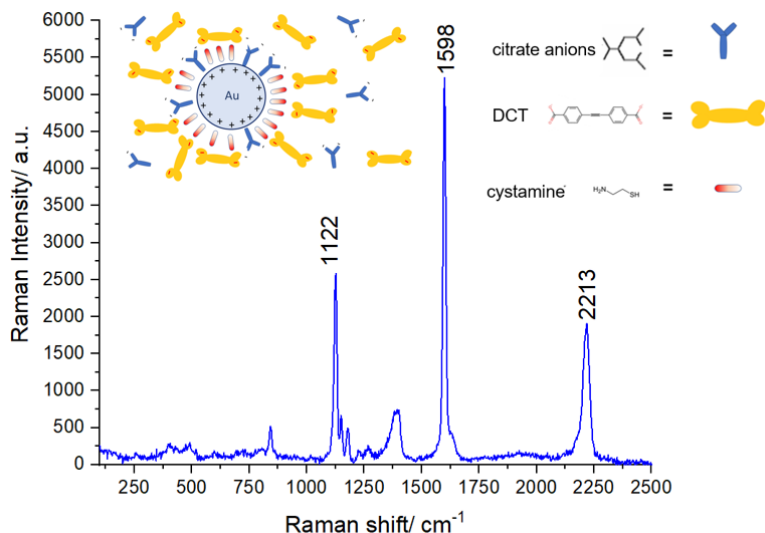
Student

[st077077@student.spbu.ru](mailto:st077077@student.spbu.ru)

Silver and gold nanoparticles possess unique optical properties, consisting in the effect of localized surface plasmon resonance, which leads to a significant increase in the intensity of light scattered and/or emitted by the molecules located near such particles. For dimers and larger agglomerates of plasmon nanoparticles (NPs), the hot spots effect is realized, when an even greater optical signal amplification is observed due to the superposition of local electromagnetic fields [1]. Due to this property, dimers of noble metal NPs are of interest as the precursors in the development of materials and metasurfaces for application as high-performance nanophotonics components. This work is addressed to the preparation and study of organo-inorganic composites, in which the inorganic part is represented by gold and silver NPs, and the organic shell is represented by a molecular linker, dicarboxytolane (DCT), which belongs to the type of ligands known as conjugated rigid rods [2].

The modification of gold and silver NPs by DCT was carried out using two methods: with and without preliminary functionalization of the surface with cysteamine. The obtained systems were studied by SERS (surface-enhanced Raman scattering), UV-Vis and fluorescence spectroscopy, and TEM (transmission electron microscopy).

The SERS and UV-Vis spectra of DCT adsorbed on silver NPs showed that DCT interacts effectively with the surface, while the resulting systems are aggregatively stable, but do not form dimers. In the case of gold NPs, the signal from DCT (the characteristic bands at 1122, 1598, 2213  $\text{cm}^{-1}$  in the SERS spectra) occurs only after preliminary functionalization of the surface with cysteamine (Figure 1). A concomitant study of the complexation of DCT with gold in the bulk solution using the method of isomolar series showed that two complexes of different stoichiometry are formed, the photochemical properties of which differ significantly.



**Figure 4.** The SERS spectrum and model representation of Au NPs modified with cysteamine and DCT.

Based on the combined analysis of the experimental data, we have proposed a model for the adsorption of DCT on silver and gold NPs in the presence and without cysteamine. The formation of dimers for silver and gold NPs modified by DCT has not been revealed, but an alternative use of them as plasmonic substrates with free surface carboxyl groups for sensory and bioanalytic applications has been proposed.

## References

- [1] *Angew. Chemie*, **2014**, 19, 4756–4795
- [2] *J. Mater. Chem.*, **2005**, 15, 690–697

**Acknowledgements.** This work was supported by the Russian Foundation for Basic Research (project No 20-33-70034). The authors thank the Resources Centers of Saint-Petersburg State University: the Interdisciplinary Center for Nanotechnology, the Center for Optical and Laser Materials Research, the Center for Chemical Analysis and Materials Research, the Centre for Physical Methods of Surface Investigation.

# SURFACE FUNCTIONALIZATION OF CARBON NANOSTRUCTURES: NEW HORIZONS IN MATERIAL DESIGN

Sviridova E.V.<sup>1</sup>

<sup>1</sup>Tomsk Polytechnic University, Tomsk, Russia

Ph.D. Student

[evs31@tpu.ru](mailto:evs31@tpu.ru)

Today, great attention has been focused on the development of new effective approach for the functionalization of carbon nanomaterials to obtain nanomaterials with tailoring surface properties and further their application in wide range of technology. However, the existing methods for functionalization of carbon nanomaterials are not enough to “fine tuning” the properties of carbon nanomaterials for the desired application and there is extremely important to develop new methods and approaches to the functionalization of carbon surfaces. In this contribution, we have exhibited two methods of covalent modification of graphene materials: using the chemistry of diazonium and iodonium salts.

The first method is represented a facile and mild approach for the covalent functionalization of reduced graphene oxide (rGO) via aryne cycloaddition using iodonium salts (pseudocyclic iodoxoborole [1]) as an aryne source and was used to improve the electrochemical performance of graphene-based materials in the energy storage devices. Covalent modification of graphene-based materials can be considered as one of the most promising methods for tailoring their electrochemical properties and extending their application as electrode materials for supercapacitors. The covalent functionalization of reduced graphene oxide (rGO) is more advantageous than non-covalent approaches due to enhanced chemical/electrochemical stability of attached functional groups. Several approaches for covalent grafting of functional groups onto rGO for supercapacitor application such as amide-coupling, attachment of conducting polymers, diazonium functionalization, heteroatom doping and azide cycloaddition have recently been described. Among the various methods for covalent functionalization, the cycloaddition of benzyne can be considered as the most promising due to the conservation of intrinsic properties of graphene and are still underdeveloped in the energy storage field. The structure and chemical composition of the functionalized rGO (f-rGO) were assessed by Fourier transform infrared (FTIR) spectroscopy, thermogravimetric analysis (TGA), ultraviolet–visible (UV-vis) absorption spectrophotometry, Raman spectroscopy and X-ray photoelectron spectroscopy (XPS), which revealed the negligible influence of covalent modification on the rGO structure. Transmission electron microscopy (TEM) imaging showed an increase of the interlayer distance from 0.38 to 0.46 nm upon functionalization. The electrochemical performance of f-rGO material was studied by cyclic voltammetry (CV), galvanostatic charge-discharge (GCD) and electrochemical impedance spectroscopy (EIS) techniques in 2 M KOH aqueous solution as the electrolyte. Under optimized conditions, the f-rGO displayed a high specific capacitance of 297 F g<sup>-1</sup> at a current density of 1 A g<sup>-1</sup>, which is much higher than that of unmodified rGO (170 F g<sup>-1</sup> at 1 A g<sup>-1</sup>). The results obtained in the present study highlight the importance of graphene functionalization as an effective route to fabricate rGO-based materials with enhanced properties in energy storage devices.

The second method is represented surface modification of carbon nanomaterials – carbon quantum dots (CDs) - by new range of diazonium salts bearing the positively charged quaternary ammonium moiety. The positive charge and structure properties of attached functional groups on the modified carbon dots' surface enhance the interactions with bacteria and show efficiency for destruct the bacteria membrane. Diazonium modified CDs were found to be effective in killing gram-positive and gram-negative bacteria, such as *S.aureus* and *E.Coli*, with a significant low concentration compared to published carbon nanomaterials. The results in this study are noted the critical role of the diazonium surface of CDs in fine tuning antimicrobial properties of nanomaterials and provided useful information for further design of highly effective antibacterial CDs for a biomedical application

## References

[1] A. Yoshimura, J.M. Fuchs, K.R. Middleton, A. V Maskaev, G.T. Rohde, A. Saito, P.S. Postnikov, M.S. Yusubov, V.N. Nemykin, V. V Zhdankin, Pseudocyclic Arylbenziodoxaboroles: Efficient Benzyne Precursors Triggered by Water at Room Temperature, *Chem. – A Eur. J.* **2017**, 23, 16738–16742.

Acknowledgements. This work was supported by Russian Foundation for Basic Research (project No 20-33-90042).

# IN SITU MODIFIED HYDROXYAPATITE NANOPARTICLES WITH DIFFERENT MORPHOLOGY AS A PERSPECTIVE STABILIZER OF PICKERING EMULSION

*Syukkalova E.A.<sup>1</sup>, Demidova N.D., Sadetskaya A.V., Osmolowsky M.G., Bobrysheva N.P., Voznesenskiy M.A., Osmolovskaya O.M.*

<sup>1</sup>Saint Petersburg State University, Saint Petersburg, Russia  
Engineer  
evgenia.syukkalova@gmail.com

Nowadays synthetic analogs of natural materials are widely introduced in biotechnology, biomedicine, bone tissue engineering, and cosmetology. Recently, a great attention has been attracted to hydroxyapatite (HAp), as it is the main mineral component of the bone tissue of living organisms and can be obtained synthetically with scalable methods.

Today the new trends in cosmetology and food industry require a “green” substitution of toxic compounds used for biocompatible inorganic products components. Growing concern about non-toxicity, especially regarding emulsions as widely applied systems, was the reason that HAp has become of particular interest for emulsion stabilization. In order to improve surface composition (change hydrophilicity of initially hydrophilic material) and functional properties of nanoparticle-based stabilizers, nanoparticles (NPs) can be modified with various substances with affinity for dispersed phase.

Current work is dedicated to the synthesis of inorganic materials based on HAp NPs with different surface compositions, which act as stabilizing components in the production of oil-in-water (o/w) type emulsions.

HAp NPs with a modified surface were synthesized by precipitation method in the presence of capping agents with a different ratio of hydrophilic / hydrophobic regions (salicylic, tartaric, succinic acids, pyrocatechol, 1,10-phenanthroline) [1]. Morphological parameters of the obtained samples were characterized by XRD, IR spectroscopy, TEM, SSA, and DLS. The resulting NPs had a rod-like shape, their dimensions were in the range of 8-15 nm (thickness) and 26-48 nm (length).

It is known that the efficiency of emulsions stabilization by NPs is influenced by the interaction between NPs and dispersed phase at the interface. It results in the surface energy decrease of droplets and the increase of the emulsion's stability. In its turn, the efficiency of NPs interaction with the surface of the dispersed phase depends on the following factors: (1) the surface composition of NPs nanoparticles (the NPs affinity to the dispersed phase), (2) the contact angle (which being in the range of 15-90 degrees leads to successful o/w type emulsion stabilization), (3) the surface charge (electrostatic interaction) and (4) the pH of the aqueous phase. In particular, each of these key factors were investigated while studying emulsions stabilized by HAp NPs.

Firstly, the effect of the pH of the aqueous phase (acidic, neutral and alkaline media) was studied. The neutral medium was shown to be more preferable for the formation of stable emulsions for all the samples.

Secondly, the effect of the NPs surface composition was studied. The zeta potential of the obtained samples varies from -4 to -35 eV, and the contact angle varies from 12 to 53 degrees. The data indicate that both of these factors have a significant effect on the stabilization process, and only a suitable combination of them allows to obtain systems with optimal characteristics. Based on the results of the first two stages, nanoparticles obtained in the presence of salicylic acid were selected as the object of research.

Finally, the effect of the NPs:oil:water ratio was studied and the conditions for emulsions obtainment were determined, the behavior of which remains unchanged for more than six months.

Thereby, it has been shown that HAp NPs can be successfully used as promising inorganic stabilizers for o/w type emulsions.

## References

[1] S. V. Kotelnikova, V. V. Suslonov, M.A. Voznesenskiy, N.P. Bobrysheva, M.G. Osmolowsky, F. Rajabi, O.M. Osmolovskaya. Effect of capping agents on Co polyol particles morphology, magnetic and catalytic properties. *Mater. Chem. Phys.* 2019. 223. P. 745–750. <https://doi.org/10.1016/j.matchemphys.2018.11.046>.

Acknowledgements. Authors appreciate the Research Park of St. Petersburg State University (Centre for X-ray Diffraction Studies, Centre for Innovative Technologies of Composite Nanomaterials, Chemical Analysis and Materials Research Centre, Centre for Optical and Laser Materials Research, and Interdisciplinary Resource Centre for Nanotechnology).

# STUDY OF THE EFFECT OF SYNTHESIS CONDITIONS ON THE SORPTION PROPERTIES OF MAGNETIC MATERIALS BASED ON LAYERED DOUBLE HYDROXIDES

Nestroinaia O.V., Tarasenko E.A., Lebedeva O.E.

Belgorod State National Research University, Belgorod, Russia  
nestroynaya91@gmail.com

Dyes and aromatic compounds that are used in the textile, food, leather processing, cosmetics and other industries have toxic effects on human health and the environment [1]. Solving the problem of effective removal of pollutants from water is environmentally important. One of the solutions to this problem is to obtain new materials with high sorption capacity. However, the use of sorbents is accompanied by technical difficulties associated with the separation and regeneration of sorbents after the adsorption process. As a solution, various methods are used, such as coagulation, precipitation, filtration or magnetic separation [2]. The magnetic separation method using an external magnetic field is one of the most effective methods for removing sorbents after adsorption [3].

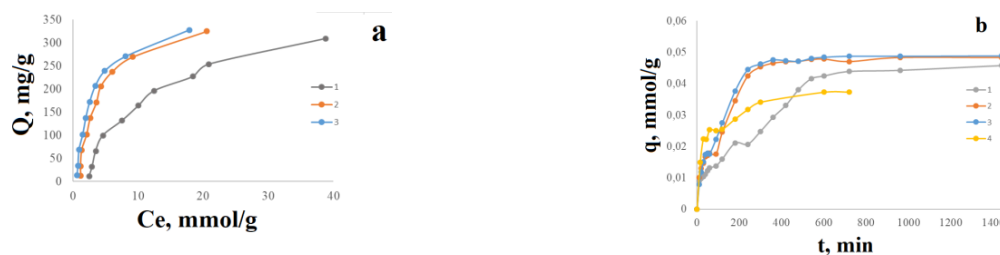
This work is devoted to the synthesis of magnetic materials based on layered double hydroxides and the study of their sorption properties.

Layered double hydroxides (LDH) are a class of natural and synthetic materials that are hydroxosalts with a layered structure. The cationic and anionic composition of LDH can vary widely, this makes it possible to obtain a wide range of materials for various purposes on their basis. In particular, LDHs are used as sorbents.

In the present study, multicomponent LDH containing double-charged magnesium and cobalt cations and triple-charged aluminum and iron cations in brucite-like layers were synthesized by co-precipitation method at variable pH in air and in an argon atmosphere. The synthesized samples were characterized by various techniques including powder X-ray Diffraction (XRD), Thermogravimetric and Differential Thermal Analysis, Scanning Electron Microscopy, Transmission Electron Microscopy, Infrared spectroscopy. Magnetic properties were studied on vibration magnetometer.

The formation of the hydrotalcite structure was confirmed by XRD measurements. The presence of an additional phase was also detected in the samples. A comparison of the diffraction pattern of the synthesized samples and the standard data suggests that the impurity phase is  $\text{CoFe}_2\text{O}_4$  (PDF2 00-001-1121) and/or  $\text{Fe}_3\text{O}_4$  (PDF2 00-001-1111). Both samples demonstrate room-temperature magnetism. There is reason to consider that the magnetic properties are due to a presence of impurity phase.

The sorption capacity of LDH in relation to anionic Congo-red dye was evaluated at different temperatures (25–45°C) (Fig. 1.a). The adsorption kinetics of sorbates onto synthesized sorbents were studied in the change of the contact times to the adsorption capacity (Fig.1.b). Such characteristics of absorbers as sorption capacity and selectivity, which are of great practical and theoretical importance, have been studied. An increase in temperature affects the sorption rate and sorption capacity. However, it is worth noting that the temperature change from 35 °C to 45 °C does not significantly affect this value. The synthesis method affects the rate of adsorption, but it is also insignificant. Adsorption of sorbates was controlled by a mixed diffusion and pseudo-second order. The sorption isotherms for all samples in a given concentration range were described by Langmuir model.



**Figure 1.** a-Isotherms of sorption of Congo red on LDHs; b- Kinetic curves of sorption of Congo red on LDH: 1- MgCo/AlFe-air (T=25°C), 2-MgCo/AlFe-air (T=35°C), 3-MgCo/AlFe-air (T=45°C), 4-MgCo/AlFe-Ar (T=25°C)

## References

- [1] Amin M.T., Alazba A.A., Manzoor U. Nanotechnology for Energy and Environment. 2014, 1–24
- [2] Mohan D., Kumar H., Sarswat A., Alexandre-Franco M, Pittman C.U. *Chem. Eng. J.* **2014**, *236*, 513–528
- [3] Safařík I., Nymburská K., Šafaříková M. *J. Chem. Technol. Biotechnol.* **1997**, *69*, 1–4

Acknowledgements. This work was supported by the Russian Foundation for Basic Research, grant № 18-29-12103.

# DIHYDROQUERCETIN LYOPHILIZATES: SYNTHESIS AND CHARACTERIZATION OF GREEN NANOMATERIALS

*Terekhov R.P., Selivanova I.A.*

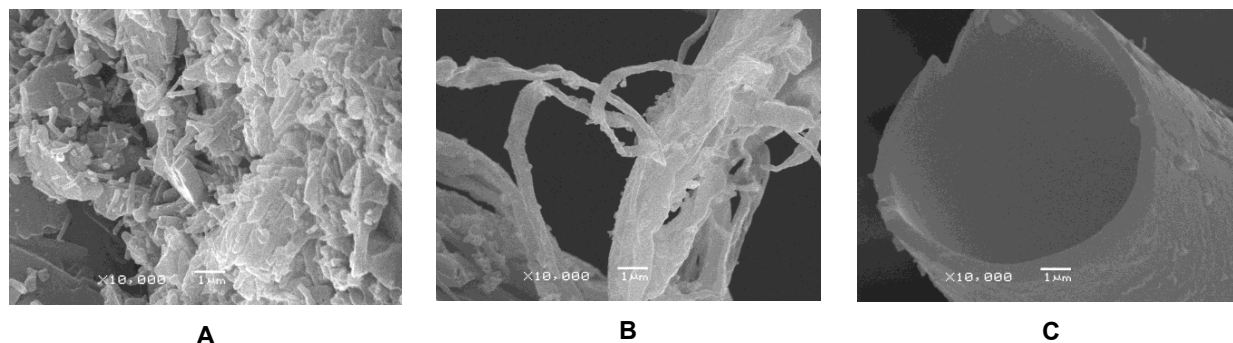
Sechenov First Moscow State Medical University, Moscow, Russia  
Postdoctoral researcher  
terekhov\_r\_p@staff.sechenov.ru

The development of nanomaterials is one of the most critical technologies for the high quality of health care. At the same time, the manufacturing of some functional materials may be environmentally hostile. The implementation of green chemistry is a smart solution to ecological problems.

The materials on the base of natural polyphenols are a promising tool for the development of new structures with advanced functionality because of their bioactivity, eco-friendliness, and cost-effectiveness [1, 2]. Dihydroquercetin (DHQ) is a natural polyphenol which characterizes by a wide range of pharmacological activity [3–5] and high safety profile [6]. So, the design of new functional materials on the DHQ basis may be beneficial for biomedical use. The goal of the current research was to synthesis the new DHQ nanomaterials by lyophilization.

Raw DHQ (Ametis JSC, Russia) was used as started material. The stock solution for the generation of each lyophilizates was prepared by the dissolution of 100 mg of DHQ in 5 mL of ethanol (99.8%, Carl Roth GmbH, Germany) or 5 ml of acetonitrile (99.8%, MERCK KgaA, Germany). The liquid samples were diluted with distilled water 20 times and kept at -78 °C for 24 h. After this step, the flasks were connected to the laboratory freeze dryer (Alpha 1-2 LD, Martin Christ efriertrocknungsanlagen GmbH, Germany), which operated under pressure of 0.35 atm and temperature -55 °C for 36 h. Samples obtained from ethanol and acetonitrile solution will be referred to hereafter as DHQ<sub>E</sub> and DHQ<sub>A</sub>, respectively.

Morphology analysis, performed by scanning electron microscopy (JSM-6380LA, JEOL Ltd., Japan), demonstrates that DHQ<sub>E</sub> and DHQ<sub>A</sub> both characterizes by nanoscale dimensionality (Fig. 1). According to infrared spectroscopy (FSM-1201, Infracpek, Russia) and mass spectrometry (LC-MS, Advion, USA) there was no changing of the molecular structure of DHQ inside the new samples. The results of X-ray powder diffraction (ARL X'TRA, Thermo Electron Corporation, USA) and thermal analysis (DSC 204 F1 Phoenix® and TG 209 F1 Iris®, NETZSCH, Germany) say DHQ<sub>E</sub> and DHQ<sub>A</sub> are amorphous materials. The new materials are freely degradable by water.



**Figure 1.** Microphotographs of DHQ samples: **A** – raw DHQ, **B** – DHQ<sub>E</sub>, **C** – DHQ<sub>A</sub>.

In this research, the new DHQ nanomaterials were synthesized. The formed feedstocks are renewable, the main solvent is water, the nanomaterials are degradable, and so this technology may be characterized as “green”. The following analysis of DHQ<sub>E</sub> and DHQ<sub>A</sub> is needed to translate these nanomaterials into medical practice.

## References

- [1] Bentley W.E., Payne G.F. *Science* **2013**, 341, 136–137
- [2] Sathishkumar P., Gu F.L., Zhan Q., Palvannan T., Yusoff A.R.M. *Mater. Lett.* **2018**, 210, 26–30
- [3] Ilyasov I.R., Beloborodov V.L., Selivanova I.A. *Chem. Paper.* **2018**, 72, 1917–1925
- [4] Terekhov R.P., Selivanova I.A. *Bull. Sib. Med.* **2019**, 18, 101–106 (in Russian)
- [5] Fischer A., Sellner M., Neranjian S., Smieško M., Lill M.A. *Int. J. Mol. Sci.* **2020**, 21, 3626
- [6] Schauss A.G., Tselyico S.S., Kuznetsova V.A., Yegorova I. *Int. J. Toxicol.* **2015**, 34, 162–181



PROPERTIES OF AQUEOUS MIXTURES BASED ON GRAPHENE OXIDE  
AND DETONATION NANODIAMONDS

*Tudupova B.B<sup>1,2</sup>, Shvidchenko A.V.<sup>1</sup>*

<sup>1</sup>Ioffe Institute, Saint Petersburg, Russia

<sup>2</sup>Peter the Great St. Petersburg Polytechnic University, Saint Petersburg, Russia  
Student

[biligma0201@gmail.com](mailto:biligma0201@gmail.com)

Due to their unique 2D structure and outstanding properties, such as large specific surface area and high electrical conductivity, graphene-based materials exhibit a great potential for application in energy storage devices like supercapacitors. However, the main issue of formation of graphene-based electrodes for supercapacitors is stacking of atomically thin graphene flakes. It leads to reduction in specific surface area of electrode material. The solution may be in making composite material of graphene flakes and conductive nanoparticles that prevent stacking.

The creation of a composite based on graphene oxide (GO) and detonation nanodiamond (DND) can be one of the possible solutions to this problem. Nanodiamond particles located between graphene flakes will prevent them stacking. Heat treatment of such composite will make it conductive.

Hereby we present the results of our research to form a composite material from aqueous dispersions of positive charged diamond nanoparticles and graphene oxide flakes in different DND/GO mass ratios. We used individual nanodiamond particles with a size 4-5 nm and their agglomerates with a size of about 100 nm.

A method for the formation of the GO-DND structures is proposed. The binding of GO flakes with DND particles was shown by method of static light scattering. Studies of pH and electrical conductivity of the resulting aqueous mixtures were carried out. Analysis of electrophoretic mobility of such structures showed the presence of an isoelectric point. The limit of DND adsorption to graphene oxide flakes was set.

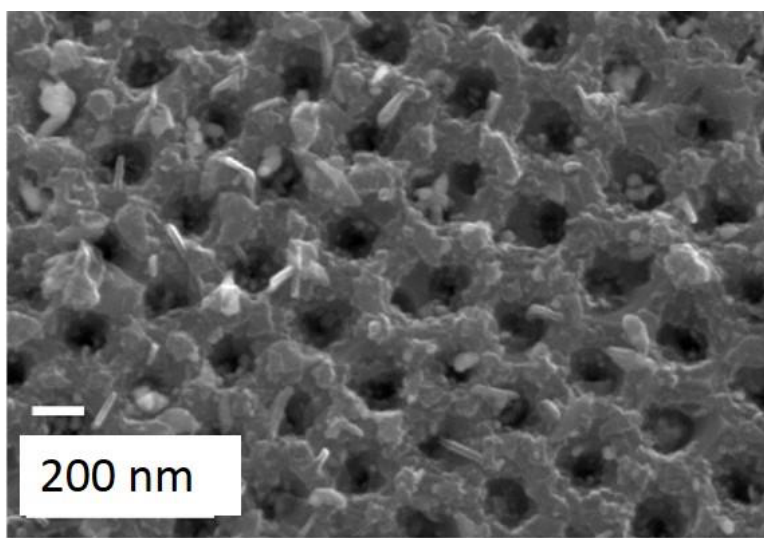
# ANODIC ALUMINUM OXIDE NANOMEMBRANES FOR CREATION OF ELECTROCATALYTICALLY ACTIVE STRUCTURES

*Vasileva A.A.<sup>1</sup>, Manshina A.A.<sup>1</sup>*

<sup>1</sup>Saint Petersburg State University, Saint Petersburg, Russia  
PhD Student  
anvsilv@gmail.com

Thankfully highly developed surface of ordered arrays anodic aluminum oxide (AAO) nanostructured templates are interesting objects for creation of electrode systems on their base. Their geometry allows constructing of electrodes with rather small visible area. Covering of AAO arrays with polyaniline (PANI) - conductive polymer provides the conductivity of the system. Developed “in situ” polymerization procedure allows cover AAO template with saving of its high aspect/ratio. With further decoration of AAO/PANI systems by different types of NPs, a range of electrocatalytic reactions is available.

One of the powerful approaches of NPs synthesis on substrates with different topologies is laser-induced deposition method (LID). This method allows formation of monometallic NPs (Ag, Au, Ru, Cu) [1] NPs and bimetallic ones (AgAu, AgPt) [2]. Figure 1 shows SEM image of silver NPs deposited on nanoporous arrays covered with PANI.



**Figure 1.** SEM image of 3D structured AAO/PANI/Ag system

Presented structures may be effective in electrocatalysis of glucose oxidation.

## References

- [1] Mamonova D.V., Vasileva A.A., Petrov Y.V., Danilov D.V., Kolesnikov I.E., Kalinichev A.A., Bachmann J., Manshina A.A. *Materials*, **2021**, *14*(1), 1–14
- [2] Vasileva A., Haschke S. Mikhailovskii V., Gitlina A., Bachmann J., Manshina A. *Nano-Structures and Nano-Objects*, **2020**, *24*, 100547

Acknowledgements. This work was supported by joint RFBR-DFG project (RFBR project № 20-58-12015, DFG project BA 4277/16-1); RFBR project №19-33-90239, by the “Scholarships of the President of the Russian Federation to young scientists and graduate students (Competition SP-2019)”, project number СП-2368.2019.1. Authors are grateful to “Centre for Optical and Laser materials research”, “Interdisciplinary Resource Centre for Nanotechnology”, “Physics Educational Centre” and “Centre for X-ray Diffraction Studies” of Research Park of Saint Petersburg State University for technical support.

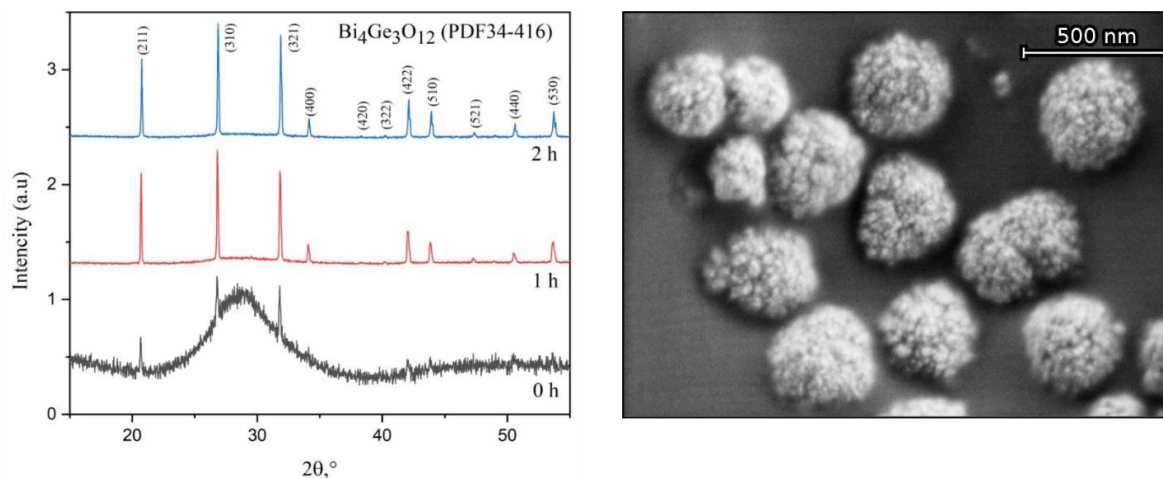
Veselova V.O.<sup>1</sup><sup>1</sup>Kurnakov institute of general and inorganic chemistry of the Russian academy of sciences, Moscow, Russia

Ph. D. student

[ibvarvara@yandex.ru](mailto:ibvarvara@yandex.ru)

Methods for production of fine  $\text{Bi}_4\text{Ge}_3\text{O}_{12}$  (BGO) powders are sought after to create ceramics or composites and lower the cost of scintillation devices. However, the task of developing such a technique is quite complex. Synthetic approaches that have previously been suggested all have certain disadvantages: they either yield particles that are too big, or require annealing at high temperatures to achieve single phase [1].

Coprecipitation is one of the simplest and most effective ways to synthesize nanoparticles, but only one case of this method has been described for BGO [2]. However, the mechanism of the process and form of existence of soluble germanium compound in nitric acid solution remains unclear, since previous studies emphasize that ammonium germanate precipitates in such conditions [3].



**Figure 1.** XRD pattern of samples freshly precipitated from  $\text{HNO}_3$  solution and aged for 1 and 2 h (left). SEM images of particles obtained by reverse precipitation from tartaric acid solution and aged for 24 h (right).

We developed the approach suggested in [2] and proved that formation of  $\text{BiGeO}_2(\text{OH})_2(\text{NO}_3)$  is not an essential step of the mechanism, despite what is claimed in [2] (Fig.1). It was also shown that single-phase submicron particles are formed at room temperature after 2 hours of aging and don't require any subsequent annealing. Solutions of nitric, chloric, tartaric, oxalic, citric acids were tested and spheres with CSR of less than 50 nm were obtained (Fig.1). Effect of concentration, order of precipitation and other synthetic parameters were determined. Conditions for production of hollow spheres and dendrites were determined. Such particles are promising for creation of scintillating materials, as it is known that BGO decay time decreases with the particle size [4].

### References

- [1] Belman-Rodriguez et al. *Ceramics International*. **2018**, *44*, 13, 15618-15621.
- [2] Kobayashi K. et al. *Japanese Journal of Applied Physics*. **2015**, *54*, 6S1, 06FJ03.
- [3] Nazarenko V. A., Andrianov A. M. *Russian Chemical Reviews*. 1965, *34*, 8, 547.
- [4] Veselova V. O. et al. *Advanced Powder Technology*. 2020.

Acknowledgements. This work was supported by IGIC RAS state assignment. XRD and SEM measurements were performed using the equipment of the JRC PMR IGIC RAS.

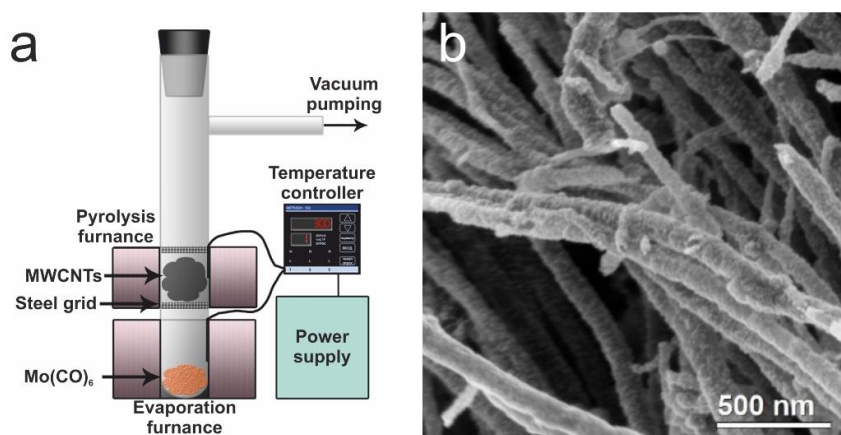
## MOCVD SYNTHESIS OF HYBRID NANOMATERIAL MoOC/MWCNT

*Vilkov I.V.<sup>1</sup>, Ketkov S.Yu.<sup>1</sup>, Obiedkov A.M.<sup>1</sup>, Aborkin A.V.<sup>2</sup>*

<sup>1</sup> G.A. Razuvaev Institute of Metalorganic Chemistry of RAS, Nizhny Novgorod, Russia  
<sup>2</sup> Vladimir State University named after Alexander and Nikolay Stoletovs, Vladimir, Russia  
Phd student

[mr.vilkof@yandex.ru](mailto:mr.vilkof@yandex.ru)

Attracted the attention of worldwide researchers the hybrid nanomaterials based on multi-wall carbon nanotubes (MWCNTs) which have surface decorating with various nanoparticles or continuous nanocoatings are budding materials. Primarily this due to the ability to radically change the properties of carbon nanotubes (CNT). Carbon nanotubes can perform as a promising template for creating catalysts and sensors of a wide number of applications due to their large specific surface area. Due to their high mechanical strength, CNTs are used as reinforcing additives in metal-matrix and polymer compositions. However, for this employment, the use of modified MWCNTs is also preferable, so far as nanocoatings or nanoparticles play the role of an interface that solves the problem of the chemical inertness of nanotubes. This work reports the possibility of creating the hybrid nanomaterial based on MWCNTs and MoOC continuous nanosized coating. MoOC/MWCNT was obtained by the metalorganic chemical vapour deposition (MOCVD) method using Mo(CO)<sub>6</sub> as a precursor.



**Figure 1.** Schematic diagram of the MOCVD setup for synthesis of the MoOC/MWCNT (a), SEM image of the MoOC/MWCNT (b)

Multi-wall carbon nanotubes were obtained by a catalytic method using ferrocene (FeCp<sub>2</sub>) and toluene (PhMe) as precursors. The synthesis of the hybrid material was carried out by the MOCVD method from vapors of molybdenum hexacarbonyl as a precursor of the nanocoating of molybdenum oxycarbide (MoOC). The MWCNT weight amount was 0.4 g, Mo(CO)<sub>6</sub> varied from 1 to 6 g. The reactor temperature was experimentally picked and amounted to 300 °C.

Various physicochemical properties were studied for samples of hybrid MoOC/MWCNT nanomaterials. According to electron microscopy, the hybrid nanomaterial is MWCNTs decorated with a continuous polycrystalline nanocoating. The thickness of MoOC layer depends on the initial quantity of Mo(CO)<sub>6</sub> and ranges from 10 to 60 nm. The nanocoating has a low degree of crystallinity, the crystallite size is 2-5 nm. According to XRD and selected area electron microdiffraction, the main crystalline phases that make up the hybrid nanomaterial are MWCNTs and cubic MoOC (PDF 00-017-0104). According to energy dispersive spectroscopy (EDS), the main chemical composition of the nanocoating is represented by the composition of Mo, C and O.

Acknowledgements. This work was supported by the Russian Science Foundation (project No 18-79-10227).

# APPLICATION OF MESOPOROUS ZEOLITE MATERIALS IN CATALYSTS FOR REACTIONS OF STERICALLY HINDERED MOLECULES. INFLUENCE OF THE MESOSTRUCTURING METHOD

*Vinogradov N.A.*<sup>1,2</sup>, *Savinov A.A.*<sup>1</sup>, *Pimerzin A.I.A.*<sup>1,2</sup>, *Glotov A.P.*<sup>2</sup>

<sup>1</sup>Samara State Technical University, Samara, Russia

<sup>2</sup>Gubkin Russian State University of Oil and Gas, Moscow, Russia

PhD Student

nikkodym@gmail.com

The deep removal of sulfur compounds from petroleum feedstock and especially from diesel is challenging and actual issue of modern oil refinery and petrochemical industry. It is becoming more difficult to produce clean fuels meeting strict specifications using conventional catalysts, especially due to continuous feedstock quality decreasing. One of the approaches to improve catalytic activity is the support modification. The addition of zeolites into support allows to increase hydrodesulfurization (HDS) activity of sterically hindered molecules such as 4,6-dimethyldibenzothiophene (4,6-DMDBT) due to the addition of isomerization activity and reaction pathway. However, some zeolites application as support leads to an undesirable cracking reaction, as well as the microporous structure leads to diffusion restrictions. One of the ways to eliminate diffusion limitations of zeolite materials is mesostructuring treatment [1]. Despite the fact that various mesostructuring methods have been proposed and studied, there are almost no references on the comparison of zeolite mesoporous materials obtained by different methods.

In our study, we obtained two mesoporous zeolite materials with quite similar textural and morphological properties based on different type Y zeolites. A mesoporous zeolite based on ultrastable faujasite (USY) was obtained in one step - by hydrothermal treatment in a solution of ammonia and cetyltrimethylammonium bromide. The material based on zeolite Y with a high aluminum content (Y) was obtained in two steps - citric acid treatment and subsequent hydrothermal treatment in a solution of ammonia and cetyltrimethylammonium bromide [2]. Based on the synthesized materials, sulfide CoMo catalysts were prepared and studied in the HDS of 4,6-DMDBT. The obtained zeolite materials as well as catalysts were studied by low-temperature nitrogen adsorption, XRD, XRF, TPD NH<sub>3</sub>, HRTEM, XPS, and FTIR of adsorbed probe molecules.

**Table 1.** Physical-chemical properties of zeolite materials.

Material	S <sub>BET</sub> , m <sup>2</sup> /g	S <sub>mic</sub> , m <sup>2</sup> /g	V <sub>mic</sub> , cm <sup>3</sup> /g	D <sub>pore</sub> , nm	Si/Al
Y	692	622	0.32	-	2.6
Meso-Y	774	401	0.24	3.5	3.4
USY	688	616	0.32	-	17
Meso-USY	825	392	0.25	3.5	17

Despite the very close textural and morphological properties of the obtained zeolite materials, they exhibit significantly different acidic properties, in particular, the ratio of Bronsted and Lewis acid sites. At the same time, the physical-chemical properties of the sulfide active CoMoS phase are quite similar for all prepared catalysts and do not depend of the zeolite material used. Meanwhile, significant differences are observed in the catalytic properties of the prepared catalysts. The Meso-USY based one exhibits the highest activity in the HDS of 4,6-DMDBT. Which is be due to the high content of Brønsted acid sites and lower aluminium density in the zeolitic framework.

## References

[1] Vu, Xuan Hoan, Udo Armbruster, Andreas Martin. *Catalysts* **2016**, 6,183

[2] Javier García-Martínez. *Catalysis Science & Technology* **2012**, 2, 987-994.

Acknowledgements. This work was supported by the Russian Science Foundation (project No 19-79-10016).

*Viushkova I.B.*<sup>1,2,3</sup>

<sup>1</sup> St. Petersburg State University of Film and Television, Saint Petersburg, Russia

<sup>2</sup> The Bonch-Bruевич Saint Petersburg State University of Telecommunications, Saint Petersburg, Russia

<sup>3</sup> Tampere University of Applied Sciences, Tampere, Finland

Student

iuliia.viushkova@internet.ru

The number of particles, or particle concentration in specific size ranges, can have a major influence in particular instances. Recent research has connected particle size to their capacity to travel through the human body, deposit in various regions of the respiratory system, and interact with live tissues and membranes via sorption, translocation, and localized chemical exposure. In any case, present data is inadequate to establish which particle indicators (number of particles of a specific size, particle surface area, and mass concentration) and, consequently, which techniques of acquiring these indicators should be employed in evaluating the effect of nanoaerosols on the body [1, 2].

This literature research discusses the indirect techniques and methods of aerosol measurement for its safety assessment, including particle size distribution detectors such as Electric Low-Pressure Impactors (ELPI), Diffusion Chargers (DC), Scanning Mobility Particle Sizers (SMPS), Nanoparticle Surface Area Monitors (NSAM), Condensation Particle Counters (CPC), and Optical particles Sizers (OPS) [3]. The paper highlights the main scope of use for every device, their methods of operation and corresponding particle size ranges, which the device is able to detect. The only direct method of characterization, which is microscopy [4], was not taken into account.

As a result, this paper proposes a unified table for the modern characterizing techniques of nanoaerosols.

#### References

- [1] Buzea, C., Pacheco, I.I. & Robbie, K. **2008**. Nanomaterials and nanoparticles: Sources and toxicity, *Biointerphases 2*. American Vacuum Society, 1934-8630
- [2] Khakharia, P. & Goetheer, E.L.V. **2016**. Overview of aerosols in post-combustion CO<sub>2</sub> capture. *Absorption-Based Post-combustion Capture of Carbon Dioxide*.
- [3] Brostrøm, A., Kling, K.I., Koponen, I.K., Hougaard, K.S., Kandler, K. & Mølhave, K., **2019**. Improving the foundation for particulate matter risk assessment by individual nanoparticle statistics from electron microscopy analysis, *Scientific Reports*, 9:8093 | <https://doi.org/10.1038/s41598-019-44495-7>
- [4] Griffiths, W.D., Mark, D., Marshall, I.A., Nichols, A.L. **1998**. *Aerosol Particle Size Analysis: Good Calibration Practices*. Harwell, Oxfordshire, UK. Aerosol Science Centre, AEA Technology.

Co<sub>3</sub>O<sub>4</sub> NANOPARTICLES MODIFIED ELECTRODES  
FOR THE DETERMINATION OF HYDROQUINONE IN WINE

*Voskanyan I.A., Kamensky M.A., Eliseeva S.N., Osmolovskaya O.M.*

Saint Petersburg State University, Saint Petersburg, Russia

Student

[vosk\\_lys@mail.ru](mailto:vosk_lys@mail.ru)

Substances of the phenol class, in particular hydroquinone and its functional derivatives, take part in biological processes and are used in the food industry. Exceeding their concentration leads to toxicity for living organisms and the environment, which is why their content must be constantly monitored.

Today, known physicochemical methods for the determination of phenol derivatives (chromatographic; chemiluminescent, fluorimetric) have insufficient productivity, selectivity, and, in general, are laborious. With a number of advantages, electrochemical methods of analysis are becoming more preferable against the others.

The hydroquinone/quinone system is a well-studied redox system in terms of electrochemical behavior. However, when using unmodified electrodes, the problem of identifying hydroquinone arises, since its peaks may overlap with the peaks of its derivatives.

We propose to use Co<sub>3</sub>O<sub>4</sub> as a modifier, since it is widely used as sensor for the detection of organic analytes (glucose, ethanol, xylene and acetone, etc.), which is due to variable valence of the compound and as it acts as a catalyst for organic reactions.

The samples were obtained by the hydrothermal method; morphological parameters were changed by varying the temperature and duration of synthesis, pH value, and the nature of the source of hydroxyl ions. The obtained samples were characterized by a set of methods: XRD (phase composition, lattice parameters and crystallite size), TEM, SEM and BET (shape and size of nanoparticles), IR-spectroscopy (surface composition).

It was shown that the synthesis at lower temperature and higher pH results in the formation of a cobalt hydroxide phase as the main one with an additional Co<sub>3</sub>O<sub>4</sub> phase. An increase in the synthesis temperature or a decrease in pH allows one to get rid of impurities and obtain a phase-pure product. The crystallite size increases from 29 to 105 nm with increasing temperature and pH, and the specific surface area decreases. Depending on the nature of the source of hydroxyl groups, the samples have a different degree of dispersion. Changes in the shape of particles with increasing temperature (from cubic to spherical) are found.

According to the literature data, hydroquinone peaks during electrochemical determination do not overlap with peaks from other electronically active substances; therefore, we rely on the selectivity of the material being developed. To test the selectivity of the material under development in the series of polyphenols, we carried out experiments with two compounds: pyrocatechol and hydroquinone directly.

The modification was carried out by applying a carbon paste containing Co<sub>3</sub>O<sub>4</sub> and a binder to the surface of the carbon electrode. The study of the electrochemical characteristics of the modified electrodes by voltammetry was first carried out on a model (sodium phosphate buffer with pH = 7 as a supporting electrolyte). We tested a number of substrates, after which the carbon electrode was chosen because it is both efficient and cheap.

The modified electrodes were tested at various scan rates, resulting in a speed of 50 mV/s, which makes the measurement fast. Also, CV curves were recorded at a number of concentrations of pure analyte and a mixture of two isomers (hydroquinone / pyrocatechol) with different ratios, on the basis of which calibration dependences (current strength versus concentration of the test substance) were constructed. For comparison, electrodes were tested in a similar way, in which there was no addition of Co<sub>3</sub>O<sub>4</sub> in the paste. Thus, the influence of the analyte and the nature of the modifier on the analytical signal was studied. It was found that the morphology of Co<sub>3</sub>O<sub>4</sub> involved in the modification affects the electrode sensitivity to one or another isomer.

Determination of the concentration of hydroquinone in wine was carried out by the standard addition method. For a complete study of the electroanalytical response in a real system, different types of wines (dry and sweet) were also considered.

It was found that the morphological parameters of Co<sub>3</sub>O<sub>4</sub> nanoparticles have a significant effect on the ability of the electrode to determine hydroquinone in wine.

Acknowledgements. The authors of the work express their gratitude to the RC of the Science Park of St. Petersburg State University "X-ray diffraction research methods", "Methods of analysis of the composition of matter."

PLASMON RESONANCE AS EFFICIENT INITIATION APPROACH  
FOR CONTROLLED RADICAL GENERATION

*Votkina D.E.*<sup>1</sup>, *Petunin P.V.*<sup>1</sup>, *Guselnikova O.A.*<sup>1</sup>, *Sylvain R. A. Marque*<sup>2</sup>, *Jean-Patrick Joly*<sup>2</sup>, *Gerard Audran*<sup>2</sup>,  
*Postnikov P.S.*<sup>1</sup>

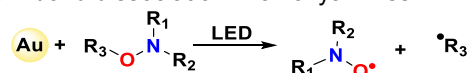
<sup>1</sup>Tomsk Polytechnical University, Tomsk, Russia

<sup>2</sup>Aix-Marseille University, Marseille, France

PhD Student

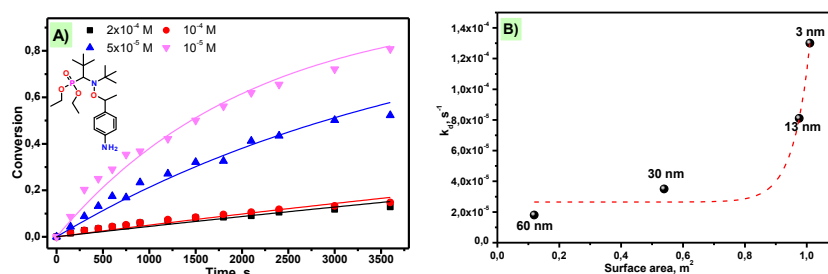
[dev2@tpu.ru](mailto:dev2@tpu.ru)

Plasmonic materials has been sparking strong interest in the field of modern chemistry as a novel catalyst. Utilization of plasmon is the principally new stimuli for the activation of organic reactions, keeping the optical energy concentrated in the vicinity of plasmonic structure, creating an optical near-field enhancement as well as hot electron injection [1]. Plasmonic energy can be applied for the initiation of chemical reactions such as the oxidation of alkyl thiophenols and alcohols [2], azo-coupling [3], palladium-catalyzed cross-coupling reactions [4], azide-alkyne cycloaddition [1]. One more promising reaction where plasmon energy might be successfully applied is controlled generation of radical species. Such initiation method for radical releasing affords a novel opportunity in medicine and chemical industry. In this work, we present for the first time the plasmon-initiated homolysis of C-ON bond dissociation in alkoxyamines.



**Figure 1.** Plasmon-induced homolysis of alkoxyamines.

We started our investigation with the synthesis of modified and non-modified spherical gold nanoparticles with different size (**AuNPs**) [5, 6, 7]. The optical properties and surface structure of **AuNPs** were estimated with UV-Vis and Raman spectroscopies and transmission electron microscopy. During evaluation of homolysis kinetic, the intriguing results were obtained. The increasing of **AuNPs** concentration as well as irradiation power increased homolysis rate. However, it was found that decreasing of alkoxyamines concentration led to enhancement of rate constant (Fig.1A) that can be explained by side reaction of oxygen triplet-singlet transformation in reaction mixture under plasmon irradiation. Next, rates of C-ON bond dissociation induced by plasmon energy of 3, 13, 30, and 60 nm nanoparticles were compared, and the exponential dependence between rate and surface area was observed (Fig.1B).



**Figure 1.** A) Dependence of homolysis rate from concentration of alkoxyamine in methanol-water solution. B) Correlation between homolysis rate constant and surface area.

Modification of gold NPs surface allowed introducing the chemoselectivity of homolysis: only amino-substituted alkoxyamines underwent plasmon-induced homolysis that could be connected with an alkoxyamine - gold surface complex formation. This fact requires further investigations.

The obtained results open up the prospects for efficient homolysis under mild conditions via controlling amount and size of nanoparticles, concentration of alkoxyamines, and power of irradiation source. The fine-tuning plasmon-induced radical generation allows chemical engineering and medical science to be more efficient, cheaper and safer.

### References

- [1] Guselnikova, O., Postnikov, P., Chehimi, M. M., Kalachyovaa, Y., Svorcik, V., Lyutakov, O. *Langmuir*, **2019**, 35(6), 2023-2032.
- [2] Akai, K., Futamata, M. *Chem. Phys. Lett.*, **2017**, 675, 63-68.
- [3] Ding, Q., Chen, M., Fang, Y., Zhang, Z., Sun, M. *J. Phys. Chem. C*, **2017**, 121(9), 5225-5231.
- [4] Wang, F., Li, C., Chen, H., Jiang, R., Sun, L. D., Li, Q., Yan, C. H. *JACS*, **2013**, 135(15), 5588-5601.
- [5] Guselnikova, O., Audran, G., Joly, J. P., Trelin, A., Tretyakov, E. V., Svorcik, V., Marque S.R.A, Postnikov, P. *Chem. Sci.*, **2021**, 12(11), 4154-4161.
- [6] Yang, H., Wang, M., Zhang, Y., Li, F., Yu, S., Zhu, L., Yang, S. *RSC Adv.*, **2019**, 9(8), 4435-4444.
- [7] Ziegler, C., Eychmuller, A. *J. Phys. Chem. C*, **2011**, 115(11), 4502-4506.

Acknowledgements. This work was supported by the Russian Science Foundation (project № 20-73-00263).



## APPLICATION OF NANOCELLULOSE TO REDUCE THE VISCOSITY OF HEAVY CRUDE OIL AND PREPARING BITUMEN EMULSIONS

*Yadykova A.Y., Gorbacheva S.N., Ilyin S.O.*

A.V. Topchiev Institute of Petrochemical Synthesis, Russian Academy Sciences, Russia  
young scientist

[yadykovaae@gmail.com](mailto:yadykovaae@gmail.com)

In recent years, the problem of production, transportation, and refining of heavy crude oil and bitumen is becoming more and more relevant due to the depleted reserves of light crude oils. The main challenge of producing heavy hydrocarbons is their high viscosity, which can reach 10 Pa·s and even more. The general methods of reducing the viscosity of heavy oils and bitumens include pipeline heating, deasphalting, mixing with lighter oil fractions and hydrocarbon solvents, but all of these methods have significant drawbacks. Current trend is emulsification of heavy hydrocarbons in water for transportation through the existing pipelines with further separation of the emulsion into two distinct liquid phases at the outlet of the pipe.

The purpose of most studies is to select emulsifiers to produce stable oil emulsions for their further transportation or application. Generally, various surfactants are applied for stabilization, but great interest is the use of solid particles, which leads to the formation of Pickering emulsions characterized by greater stability than traditional oil-in-water systems. Clay, silica, and cellulose are usually used as such particles, but only cellulose has such advantages as biodegradability and renewability.

To reduce the viscosity of heavy crude oil and preparing bitumen emulsions, it was decided to use nanocellulose (namely nanofibrillated cellulose due to the simplicity of its production), as well as sodium dodecyl sulfate (SDS) as an additional stabilizer. As a result, two series of emulsions containing either nanocellulose alone or in combination with SDS were obtained. When studying the morphology and rheology of samples, it turned out that the use of cellulose particles led to the formation of emulsions stable for a long time – at least six months. However, by using cellulose alone it is not possible to emulsify more than 40 vol.% of heavy hydrocarbons, because at its higher concentrations inverse emulsions were formed. The introduction of SDS changes the situation and allows obtaining concentrated oil-in-water emulsions contained up to 80 vol. % of heavy hydrocarbons; moreover, the resulting emulsions have lower yield stress and effective viscosity, while their application allows reducing energy costs for the transportation of heavy oil up to 13 times.

Acknowledgements. This work was supported by the Russian Science Foundation (project № 19-79-10283).

# OXIDATION CONTROL USING PULSE BURST IRRADIATION IN FEMTOSECOND LASER-REDUCTIVE SINTERING OF CU MICROPATTERNING

*Yoshidomi K.<sup>1</sup>, Mizoshiri M.<sup>1</sup>*

<sup>1</sup>Nagaoka University of Technology, Nagaoka, Japan

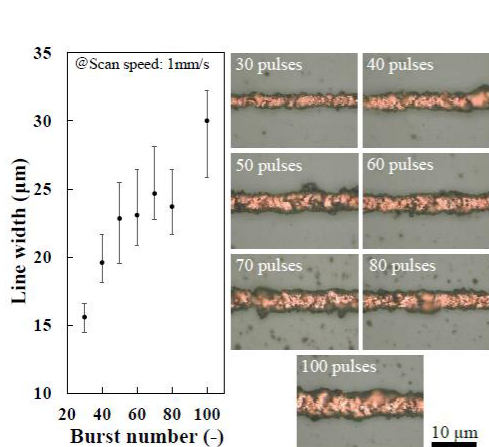
Student

[s193097@stn.nagaokaut.ac.jp](mailto:s193097@stn.nagaokaut.ac.jp)

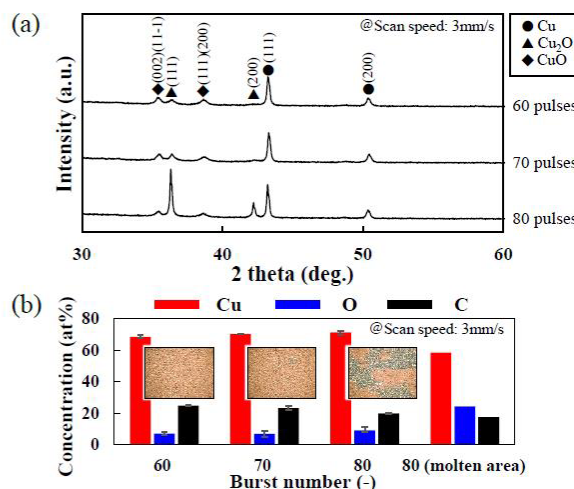
Metal printing technology for the fabrication of microdevices has attracted attention in the Internet of Things (IoT). We have reported Cu microfabrication by reducing CuO nanoparticles in the air using femtosecond laser pulses [1-2]. However, the line width was significantly larger than the laser spot diameter because of the thermal diffusion. In addition, the reoxidation was also caused during the reductive sintering by atmospheric oxygen. In this presentation, we evaluated the line width and the degree of reduction of the patterns fabricated by laser irradiation in the burst mode to reduce the thermal diffusion.

CuO nanoparticle pastes were prepared by mixing CuO nanoparticles (<50 nm, 60 wt%), a dispersant polyvinylpyrrolidone (13 wt%), and a reductant ethylene glycol (27 wt%), and spin-coated onto glass substrates. Then, a near-infrared femtosecond laser (wavelength: 780 nm, pulse duration: 120 fs, repetition frequency: 80 MHz) focused using an objective lens (numerical aperture: 0.45) on the sample substrates which were scanned to form Cu patterns. The patterns were fabricated with different burst numbers at the burst repetition frequency of 0.80 MHz. The time distance between sequential pulse was 12.5 ns. The burst of number of pulses were changed from 50 to 80 pulses. The line width was measured using optical microscope images. The crystal structures and the atomic concentration of the patterns (3x3 mm<sup>2</sup>) fabricated with a raster pitch of 5 μm were examined using x-ray diffraction (XRD) analysis and energy dispersive x-ray spectroscopy (EDS).

The line widths and microscopic images of the fabricated line patterns are shown in Fig. 1. The line width decreased with the decrease of the number of pulses, suggesting that the thermal diffusion decreased by decreasing incident energy. The XRD spectra and EDS atomic concentrations of the patterns fabricated with different pulse numbers are shown in Fig. 2(a) and 2(b), respectively. The EDS analysis exhibits that the oxygen concentration in the molten area (gray area) was 24.2% and that in the brown area was 9% at the burst number of 80 pulses. On the other hand, the oxygen concentration of 70 and 60 pulses was 6.8% and 7%, respectively, which was lower than that of 80 pulses. This lower oxidation was attributed to the decrease in Cu<sub>2</sub>O as shown in Fig. 2(a). These results indicate that it is possible to control the reduction of the pattern formed by laser reduction drawing using pulse burst irradiation.



**Fig. 1** Line widths and microscopic images of line patterns fabricated with different burst numbers.



**Fig. 2** (a) XRD spectra and (b) atomic concentrations of patterns fabricated with different burst numbers.

## References

- [1] M. Mizoshiri, *et al.*, *Appl. Phys. Express.*, **2016**, 9, 036701.
- [2] S. Arakane, *et al.*, *J. Micromech. Microeng.*, **2017**, 27, 055013

Acknowledgements. This work was supported by Funds for the Development of Human Resources in Science and Technology "2019 Initiative for Realizing Diversity in the Research Environment (Leading Type)"; The Ministry of Education, Culture, Sports, Science, and Technology (MEXT); and KAKENHI 20H02043.

## NONDESTRUCTIVE ADSORPTION OF LIPOSOMES ON THE SOLID SURFACES

Zaborova O.V.

Lomonosov Moscow State University, Moscow, Russia  
Senior researcher  
olga.zaborova@gmail.com

Liposomes are the spherical vesicles formed from natural and synthetic lipids ranging in size from 20 nm to several micrometers. Due to their size and amphiphilic character, liposomes are used as perspective systems for drug delivery. There are several liposomal formulations on the market based on so-called "conventional" liposomes. Such liposomes have several disadvantages as small internal volume, low mechanical, and aggregative stability, etc.

Modification of liposomes with polyelectrolytes allows to overcome some of these disadvantages, but often the formation of the polymer/liposome complex leads to undesirable aggregation of the system. In addition, adsorption of polyelectrolytes on vesicles causes a number of structural reorganizations in the lipid membrane that can cause the disruption of liposomes. Adsorption of liposomes on a surface allows to control the quantity of adsorbed liposomes, but the interaction with a surface leads to the partial destruction of liposomes.

One of the most successful approaches for concentrating of liposomes on a surface is electrostatic adsorption of anionic liposomes on the cationic colloidal particles, polystyrene core with grafted linear polycationic chains [1]. This method allows to concentrate dozens of liposomes without their destruction. However, this approach assumes existence of a "soft" layer between a liposome and a surface, which introduces its limitations on the nature of the carrier surface.

Modification of a surface of solid particles is rather a difficult task, thus the purpose of this work was to investigate the possibility to use a "soft" layer on liposomes instead of the surface. We used anionic latex particles as a model surface. The electrostatic adsorption of liposomes on the latex was ensured by using the cationic lipid. The "soft" layer was formed by polyethylene glycol (PEG) covalently attached to the lipid. The most efficient amount of the PEGylated lipid was to prevent the liposomal disruption was evaluated using different methods (conductivity, Langmuir trough, TEM).

### References

[1] A.A. Yaroslavov, A.V. Sybachin, O.V. Zaborova et al. *Adv. Colloid Interface Sci.* **2015**, 226, 54–64

Acknowledgements. This work was supported by the Scholarship of the President of Russian Federation (project No СП-2803.2021.4).

# UNDERPOTENTIAL AND OVERPOTENTIAL DEPOSITION OF COPPER ON A Pt(111) SINGLE CRYSTAL FROM DEEP EUTECTIC SOLVENTS

*Zaytsev O.L., Molodkina E.B., Ehrenburg M.R., Rudnev A.V.*

Frumkin Institute of Physical Chemistry and Electrochemistry Russian Academy of Sciences, Moscow, Russia

Student

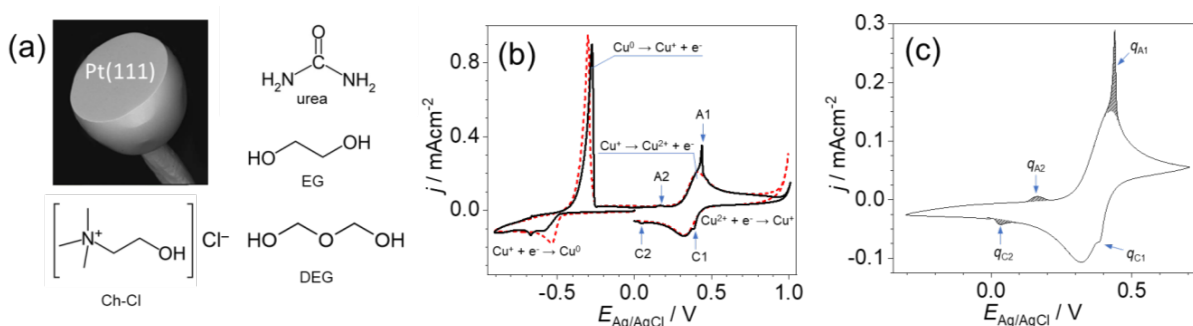
olza2000@yandex.ru

**Introduction:** Significant attention is paid to the electrodeposition of metals from ionic liquids (ILs) and deep eutectic solvents (DESs) [1-2]. ILs are characterized by unique properties, such as chemical, thermal, and electrochemical stability, non-volatility, and high ionic conductivity, which makes them a good alternative for replacing aqueous electrolyte solutions. DESs of the third type (a mixture of quaternary ammonium salts as hydrogen bond acceptors, HBAs, with hydrogen bond donors, HBDs) are similar in properties to ILs, but have advantages over them, such as ease and low cost of synthesis, non-toxicity, and biodegradability. The underpotential (UPD) and overpotential (OPD) deposition of Cu from aqueous solutions have been thoroughly studied. Therefore, copper deposition is a good model process for studying the metal deposit nucleation and growth in ILs and DESs.

**Methods:** The process of UPD and OPD of Cu is studied by cyclic voltammetry and potentiostatic current transients using a home-built potentiostat. The morphology of deposits is characterized by atomic-force microscopy (Solver Pro, NT-MDT). Pt(111) and Pt(poly) electrodes are half-bead single crystals (Fig. 1a) prepared according to Clavilier's method [3].

**Results:** Copper UPD and OPD is studied from DESs based on choline chloride (Ch-Cl) and different HBDs, such as urea, ethylene glycol (EG), and diethylene glycol (DEG), on Pt(111) and Pt(poly) (Fig. 1a). Typically, two main cathodic waves are observed on both electrodes: reduction of  $\text{Cu}^{2+}$  to  $\text{Cu}^+$  and  $\text{Cu}^+$  to  $\text{Cu}^0$  (Cu OPD, Fig. 1b). Anodic peaks correspond to the respective anodic processes (see designations in Fig. 1b). However, there is a clear difference in the CV shape for Pt(111) and Pt(poly). Small peaks in the potential range more positive than  $\text{Cu}^0$  deposition (denoted as A1/C1 and A2/C2) are observed for Pt(111) (Fig. 1c). These peaks are absent in CVs recorded in Cu-free solutions. Thus, they can be attributed to a phase transition in an adsorbate layer forming on (111) terraces and containing Cu ions or adatoms (Cu UPD layer). The anodic peak area integration (after subtraction of background current) leads to the following charge densities:  $q_{A1} = 37 \mu\text{C cm}^{-2}$  and  $q_{A2} = 188 \mu\text{C cm}^{-2}$ . The total charge density is  $225 \mu\text{C cm}^{-2}$ , which is close to the theoretical charge density for formation (or dissolution) of a full monolayer of Cu adatoms ( $240 \mu\text{C cm}^{-2}$ ).

**Conclusions:** The formation of Cu UPD adlayer on Pt electrodes in aqueous solutions is well documented and occurs in a two-electron reaction:  $\text{Cu}^{2+} + 2e^- \rightarrow \text{Cu}_{\text{ad}}$ . In this study, we demonstrated for the first time voltametric signals on a Pt(111) electrode that can be assigned to Cu UPD in DESs. The charge analysis supports the attribution of these signals to Cu UPD according to the reaction of  $\text{Cu}^+ + e^- \rightarrow \text{Cu}_{\text{ad}}$ .



**Figure 1.** (a) SEM image of Pt(111) single crystal and chemical structures of choline chloride, HBA, and different HBDs. (b) Cyclic voltammograms (CVs) of Pt(111) (solid black line) and Pt(poly) (red dashed line) in ChCl-2EG + 10 mM CuCl. The reactions and UPD processes are indicated in the figure. (c) CV of Pt(111) in the UPD potential range with indication of integrated peaks. The sweep rate in CVs was  $0.01 \text{ Vs}^{-1}$ .

## References

- [1] Electrodeposition from Ionic Liquids, Wiley-VCH Verlag GmbH & Co. KGaA, Weinheim, 2017.
- [2] *Russ. Chem. Rev.*, **2020**, 89, 1463-1482.
- [3] Interfacial Electrochemistry: Theory, Experimental, and Applications, Marcel Dekker, New York, 1999, pp. 231-248.

**Acknowledgements.** The work was supported by the Ministry of Science and Higher Education of the Russian Federation.

# SELF-ASSEMBLY, STRUCTURE AND SPECTRAL PROPERTIES OF SUPRAMOLECULAR COMPLEXES OF BIS(AZA-18-CROWN-6)-CONTAINING DIENONE WITH DIAMMONIOPROPYL DERIVATIVE OF DIPYRIDYLETHYLENE

*Zdorovenko I.P.<sup>1,2</sup>, Fomina M.V.<sup>2</sup>, Gromov S.P.<sup>1,2</sup>*

<sup>1</sup>Moscow State University, Moscow, Russia

<sup>2</sup>Photochemistry Center of RAS, FSRC "Crystallography and Photonics", Russian Academy of Sciences, Moscow, Russia

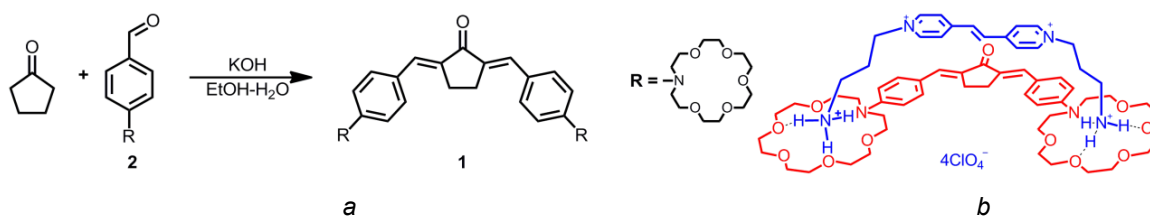
Student

[ilia.zdorovenko@gmail.com](mailto:ilia.zdorovenko@gmail.com)

Charge-transfer complexes based on organic compounds are considered as promising components of molecular electronic devices for efficient solar energy conversion, photochromic materials, photoactive switches in optoelectronics and optical chemosensors. In this regard, bisazacrown-containing dienones, which combine chromophore and ionophore fragments in their structure, are of undoubted interest.

The aim of this work was to synthesize bis(aza-18-crown-6)-containing dienone of the cyclopentanone series (**1**) and to study the features of its complexation with  $\text{Ca}^{2+}$  cations, tetraperchlorate of diammoniopropyl dipyriddyethylene derivative.

Bisazacrown-containing dienone **1** was obtained by condensation of cyclopentanone with azacrown-containing aldehyde **2** in the presence of an aqueous alkali solution.



**Figure 1.** Synthesis of bis(aza-18-crown-6)-containing dienone **1** (a), structure of the pseudocyclic complex **1** (b) with the diammoniopropyl dipyriddyethylene derivative

The structure of the resulting dienone **1** was determined by complex of independent methods (NMR, IR, electron spectroscopy, elemental analysis data). The complexation of dienone **1** with a diammoniopropyl derivative of bipyridylethylene and  $\text{Ca}^{2+}$  cations was studied by electron and <sup>1</sup>H NMR spectroscopy. It was found that bis(azacrown)dienone **1** forms stable 1:1 and 1:2 complexes with  $\text{Ca}^{2+}$  cations, and pseudocyclic 1:1 complex with a diammoniopropyl derivative of dipyriddyethylene. The complexation **1** with a dipyriddyethylene derivative is accompanied by quenching of the emission **1**, which indicates the formation of a charge transfer complex [1]; the addition of  $\text{Ca}^{2+}$  cations leads to the destruction of the charge transfer complex and accompanied by fluorescence enhancement **1**.

The stability constants of the resulting complexes were determined by spectrophotometric and fluorescence titration methods. Bisazacrown-containing dienones and supramolecular systems based on them can be used to determine the presence of metal ions and organic cations in the environment and biological fluids, which opens up opportunities for their use for analytical purposes.

## References

[1] Vedernikov, A.I.; Ushakov, E.N., Efremova A.A. et al., *J. Org. Chem.* **2011**, 76, 6768–6779

Acknowledgements. This work was supported by the Russian Science Foundation (project No 19-13-00020).

# EFFECT OF DOPED HYDROXYAPATITE SHELL ON THE MAGNETIC PROPERTIES AND THE MRI SIGNAL OF MAGNETITE NANOPARTICLES

*Zheltova V.V., Vlasova A.A., Bobrysheva N.P., Abdullin I.R., Semenov V.G., Osmolowsky M.G., Voznesenskiy M.A., Osmolovskaya O.M.*

Saint Petersburg State University, Saint Petersburg, Russia  
Student

[vic.zheltova@yandex.ru](mailto:vic.zheltova@yandex.ru)

Magnetic Resonance Imaging (MRI) is a non-invasive imaging technique that produces three dimensional detailed anatomical images. The main material to produce the T2 contrast agent is the Fe<sub>3</sub>O<sub>4</sub> ferrimagnetic nanoparticles. However, Fe<sub>3</sub>O<sub>4</sub> magnetic nanoparticles are not widely used in clinical practice probably due to the simple surface oxidation process. We chose hydroxyapatite as a material for the shell production, guided by its biocompatibility and wide use in medicine. As a result of our in vitro experiments to study the visualization capabilities of Fe<sub>3</sub>O<sub>4</sub>@HAp nanoparticles in the MRI method, an increase in the intensity of negative contrast was recorded in comparison with the signal from magnetite nanoparticles without a shell [1]. The next step in the study of magnetite nanoparticles is the creation of multifunctional luminescent contrast agents based on Fe<sub>3</sub>O<sub>4</sub>@HAp particles. Chromium (3d-element) and terbium (4f-element) were chosen as dopants due to their fluorescent properties and the ability to have a different effect on the process of shell formation to create multifunctional luminescent Fe<sub>3</sub>O<sub>4</sub>@Cr(Tb)-HAp agents.

Nanoparticles morphological parameters were characterized using XRD, FTIR, TEM, BET, XPS and luminescence spectroscopy. The visualization capabilities of Fe<sub>3</sub>O<sub>4</sub>@Cr(Tb)-HAp nanoparticles in the MRI method were investigated. We studied the effect of the synthesis temperature (100, 140, and 200 °C), the content of the shell substance (10 and 20 mol.% hydroxyapatite) and the nature of the dopant (Cr, Tb) on the morphology of nanoparticles Fe<sub>3</sub>O<sub>4</sub>@Cr(Tb)-HAp. It is shown that with an increase in the molar content of HAp, the thickness of the shell increases with the retention of crystallinity. In the case of a decrease in the shell thickness upon temperature increase (or with an increase in the HAp content), the crystallinity of the surface layer increases. The shell thickness is higher for Tb<sup>3+</sup>-doped particles than for Cr<sup>3+</sup>-doped particles.

The influence of the composition and thickness of the shell on the magnetic properties of the samples were investigated. It was found that the features of the superparamagnetic behavior of particles are due to both the thickness of the shell and the presence of paramagnetic dopants. The photoluminescence of the samples depends on the degrees of crystallinity of magnetite and the shell composition. Doping leads to an increase in the photoluminescence intensity, Terbium-doped sample obtained at 200 °C with 20 mol.% HAp demonstrates optimal luminescence parameters (high intensity for all detected peaks).

Investigation of the visualization capabilities of the obtained nanoparticles in the MRI method and their influence on the relaxation times have been carried out. It is shown that the relaxation time T2 decreases linearly with an increase in the degree of crystallinity of the shell. The lowest (more optimal) relaxation time was obtained in the case of the presence of terbium in the shell; the sample obtained at 200 °C with 20 mol.% HAp is also optimal.

It is shown that a change in the synthesis parameters and the introduction of dopants of various natures make it possible to vary both the thickness and crystallinity of the shell of magnetite nanoparticles. The obtained data and the established regularities indicate that the introduction of a dopant leads to an increase in the photoluminescence signal, which makes it possible to recommend synthesized particles as luminescent labels.

## References

[1] Zheltova V., Vlasova A., Bobrysheva N., Abdullin I., Semenov V., Osmolowsky M., Voznesenskiy M., Osmolovskaya O. *Applied Surface Science*, **2020**, 531, 147352.

Acknowledgements. This work was supported by Russian Foundation for Basic Research (project No 18-03-01066-a). Scientific research was performed using the equipment of the Research Park of St. Petersburg State University (Centre for X-ray Diffraction Studies, Chemical Analysis and Materials Research Centre, Centre for Innovative Technologies of Composite Nanomaterials, Centre for Optical and Laser Materials Research, Centre for Magnetic Resonance).

# THE NOVEL HIGH-ENTROPY CERAMICS WITH A PEROVSKITE STRUCTURE SYNTHESIS

*Zhivulin V.E.<sup>1</sup>, Gudkova S.A.<sup>1</sup>, Punda A.Yu.<sup>1</sup>, Trofimov E.A.<sup>1</sup>, Vinnik D.A.<sup>1</sup>*

<sup>1</sup>South Ural State University (National Research University), 454080, Lenin ave.76, Chelyabinsk, Russia  
Young Scientist  
[zhivulinve@mail.ru](mailto:zhivulinve@mail.ru)

This work is devoted to studying the possibility of high entropy ceramics with a perovskite structure synthesis. Systems with high mixing entropy are usually understood as compounds in which at least 5 different components act as one of the cations.

Perovskites are a general name for compounds, the chemical formula of which can be generally represented as  $ABO_3$ . Various elements can act as cations A and B. Some materials with a perovskite structure have unique physical properties.

In this work, we study the possibility of compounds formation with the general formula  $(Cr, Mn, Fe, Co, Ni)BO_3$ , where two or more rare earth elements from the following list act as the B cation: Nd, Pr, La. Such multicomponent systems have a high configurational components mixing entropy of the cationic sublattices, and taking into account the elemental composition, one can expect them to display interesting magnetic and electrical properties.

Experimental samples were synthesized by solid-phase sintering. Chromium oxides  $Cr_2O_3$ , manganese  $Mn_2O_3$ , iron  $Fe_2O_3$ , cobalt  $CoO$ , and nickel  $NiO$  were taken as the sources of the initial components for replacing the position A. The oxides of neodymium  $Nd_2O_3$ , praseodymium  $Pr_2O_3$ , and lanthanum  $La_2O_3$  were taken as a source of rare earth cations for cation B position substitution. The initial components were measured in stoichiometric ratios, mixed and ground for 1 hour in an agate mortar.

The resulting mixture of oxides was pressed in a metal mold on a hydraulic press. The pressing force was 3 tons per  $cm^2$ . The tablets obtained as a result of pressing were placed in a high-temperature oven on a platinum substrate and sintered at a temperature of  $1400^\circ C$  for 5 hours.

The phase composition and structure of the obtained samples (Table 1) were studied by powder X-ray diffraction. According to powder X-ray diffraction data, the synthesized samples are single phase. Table 1 shows the calculated unit lattice parameters.

**Table 1.** Parameters of the crystal structure of the obtained compounds

№	Chemical composition	Crystal system	Lattice parameters, Å		
			a	b	c
1	$(Cr, Mn, Fe, Co, Ni)(Nd)O_3$ [1,2]	Orthorombic	5.4086(4)	5.4752(4)	7.6717(6)
2	$(Cr, Mn, Fe, Co, Ni)(Pr)O_3$		5.4377(9)	5.4596(7)	7.6904(12)
3	$(Cr, Mn, Fe, Co, Ni)(La)O_3$ [1,2]		5.4886(5)	5.4828(6)	7.7872(12)
4	$(Cr, Mn, Fe, Co, Ni)(Nd, La)O_3$ [2]		5.4548(9)	5.4592(6)	7.7112(14)
5	$(Cr, Mn, Fe, Co, Ni)(Nd, Pr)O_3$		5.4260(6)	5.4674(5)	7.6820(9)
6	$(Cr, Mn, Fe, Co, Ni)(La, Pr)O_3$		5.3355(4)	5.5039(4)	7.6001(5)
7	$(Cr, Mn, Fe, Co, Ni)(Nd, Pr, La)O_3$		5.3225(2)	5.5164(2)	7.5913(3)

As a result of the work done by the method of solid-phase synthesis, single-phase samples of ceramics with a high configurational components mixing entropy were obtained. Analysis of literature data showed that 4 out of 7 obtained compositions were synthesized for the first time. All the compounds obtained have a perovskite crystal structure. The next stage of the work will be the study of the magnetic and electrophysical properties of the materials obtained.

## References

- [1] Abhishek Sarkar, Ruzica Djenadic, Di Wang, Christina Hein, Ralf Kautenburger, Oliver Clemens, Horst Hahn. *Journal of the European Ceramic Society*. **2017**, 38, 2318-2327.  
[2] V.E.Zhivulin, E. A. Trofimov, S. A. Gudkova, I. Yu. Pashkeev, A. Yu. Punda, M. Gavrilyak, O. V. Zaitseva, S. V. Taskaev, F. V. Podgornov, M. A. Darwish, M. A. Almessiere, Y. Slimani, A. Baykal, S. V. Trukhanov, A. V. Trukhanov, D. A. Vinnik. *Nanomaterials*. **2021**, 11, 1014.

Acknowledgements. The work was supported by the Russian Science Foundation, project No. 19-73-10046.

Zirnik G.M.<sup>1</sup>, Chernukha A.S.<sup>1</sup><sup>1</sup>South Ural State University, Chelyabinsk  
Student  
glebanaz@mail.ru

Recently, only in 2008, it was found that carbon nitride possesses photocatalytic activity when irradiated with visible light [5]; also, the advantages of this material are its chemical stability, non-toxicity, ease of preparation and precursors availability [6]. These properties of carbon nitride make it possible to use it in wastewater treatment [1], in hydrogen production [3], in photovoltaics [2]. The photocatalytic activity of carbon nitride is explained by the generation of an electron/hole pair ( $e^-/p^+$ ) upon irradiation, as well as a relatively small band gap ( $E_g \sim 2.7$  eV) and a wide absorption spectrum of carbon nitride [6]. At the same time, it is worth noting the high recombination of the charge of the  $e^-/p^+$  pair in pure carbon nitride (that is, a low "life span") [4]. Because of this, the main task of the researchers was to reduce the band gap CN and increase the stability of charge separation in a semiconductor [4], as well as increase the absorption spectrum of the material [2]. In this work, the method of molecular doping was applied, which, through the local distribution of the electron density, would reduce the band gap of the material and would increase the photocatalytic activity.

A line of 4-amino-2,1,3-benzochalcogenediazoles was chosen as a dopant. Melamine powder was mixed with dopants in a certain ratio, after which it was sintered in an oven. After synthesis, a sample of doped carbon nitride was characterized by XRD, IR- and UV-vis spectroscopy, photocatalytic tests for hydrogen production were carried out according to the method described in the literature. The gas mixture was analyzed using a gas chromatograph. Below are the results of photocatalytic tests:

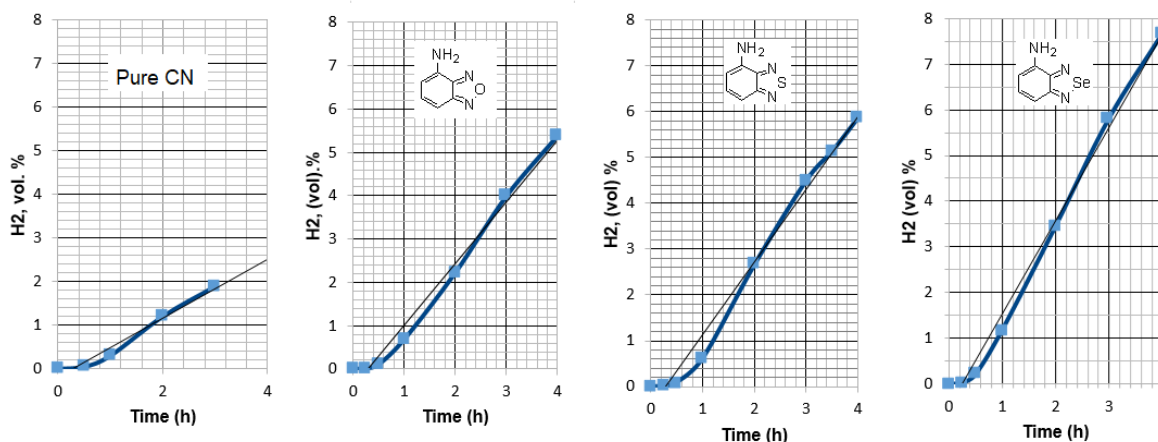


Figure 1. Photocatalytic H<sub>2</sub> production in the presence of carbon nitride.

It can be seen from the graph that doped carbon nitride exhibits better photocatalytic activity than pure carbon nitride under ultraviolet light irradiation conditions.

### References

- [1] Wang K., Maeda K., Thomas A., Takanabe K., Xin G., Carlsson J.M. *Nat. Mater* **2009**, *8* (1), 76–80
- [2] Arvaniti O.S., Petala A., Zalaora A.A., Mantzavinos D. *Chem. Technol. Biotechnol* **2020**, *95* (11), 2811–2821
- [3] Martin D.J., Qiu K., Shevlin S.A., Handoko A.D. *Angew. Chemie - Int. Ed* **2014**, *53* (35), 9240–9245.
- [4] Joshua C.B., Deslouis C., Pailleret A., Semenikhin O.A. *Russ. J. Electrochem* **2020**, *56* (10), 859–867
- [5] Xiang Q., Yu J., Jaroniec M. *J. Phys. Chem. C* **2011**, *115* (15), 7355–7363
- [6] Ong W.J., Tan L.L., Ng Y.H., Yong S.T., Chai S.P. *Chem. Rev.* **2016**, *116* (12), 7159–7329.

Acknowledgements. This work was supported by Russian Foundation for Basic Research (project № 20-43-740024).





# **ORGANIC AND BIOMEDICAL CHEMISTRY**

## SYNTHESIS AND CHEMICAL PROPERTIES OF WATER-SOLUBLE DERIVATIVE STERICALLY HINDERED PHENOLS

*Akhmetova A.A., Shulaeva L.V., Bakieva E.R., Shamsutdinova L.P.*

Kazan National Research Technological University, Kazan, Russia.

Student

[ahmetova2001@mail.ru](mailto:ahmetova2001@mail.ru)

Ionol 2,6-Di-tert-butyl-4-methylphenol is an effective inhibitor of free-radical processes in the suppression of malignant neoplasms in animals. However, in biological experiments it's necessary to use its high concentration oil solutions.

We are pursuing research of the synthesis and chemical properties of the reaction products of substituted 4-hydroxy-3,5-di-tert-butylbenzylamines - phenolic Mannich bases (PMB) of various structures with phosphorous acid.

It was found that the structure and composition of phenolic Mannich bases reaction products with phosphorous acid depend on the molar reagents ratio. It's shown that the phenolic Mannich bases reaction with two equivalents of phosphorous acid relative to the nitrogen atom in the phenolic Mannich bases composition in the direct interaction of reagents or in the presence of solvent leads to formation of salt-like products of supramolecular structure of the  $\text{PMB} \cdot 2\text{H}_3\text{PO}_3$  composition (I-IV).

The salt-forming reaction with phosphorous acid was studied in detail by the example of dimethyl-4-hydroxy-3,5-di-tert-butylbenzylamine (PMB-1), which leads to the formation of  $\text{PMB-1} \cdot 2 \text{H}_3\text{PO}_3$  (V).

The yield of the reaction products is 65-85%; their structure and composition are substantiated evidence of elemental analyses and spectral characteristics. The resultant salts (I-V) are colorless, nonhygroscopic, well-crystallizing products with unrestricted storage stability.

Synthesized compounds (I-V), which differ in the structure of the para-alkyl substituent, form a structural series that opens up a certain research perspectives of product structure relation with their antioxidant properties and biological activity (bioactivity).

Compounds (I-V) are characterized by high solubility in water (~ 1:2-1:3) of aqueous solutions of compound (I), which has a prismatic crystal shape; in 1-2 minutes after complete dissolution other (needle-like) shaped crystals precipitate. Composition analysis of generated product shows that compound (I) loses one molecule of phosphorous acid with the formation of salt  $\text{PMB-1} \cdot \text{H}_3\text{PO}_3$  (VI) with a yield of 54%.

The behavior of compound (I) and (VI) has been studied under the influence of organic bases and phosphorous acid and their spatial structure by X-ray diffraction method (RX).

The unusual molecular ratio of amine-phosphorous acid in the composition of compounds (I-V) and the IR spectroscopy data of compound (VI) are a valid reason for further research of the structure of compounds (I) and (VI).

It can be concluded, therefore, that Mannich bases containing a sterically hindered phenolic hydroxyl are forming with phosphorous acid two stoichiometric series of supramolecular structures that are fundamentally-different from each other in structure. High solubility in water does not depend on the stoichiometry of products.

# TRIPLE ROLE OF THIOCYANATE-CONTAINING PROTIC IONIC LIQUIDS: REAGENT, CATALYST, AND SOLVENT

*Andreev I.A.*<sup>1,2</sup>, *Ratmanova N.K.*<sup>1</sup>, *Ivanova O.A.*<sup>2,3</sup>, *Trushkov I.V.*<sup>1,2</sup>

<sup>1</sup>Dmitry Rogachev National Medical Research Center of Pediatric Hematology, Oncology and Immunology, Moscow, Russia

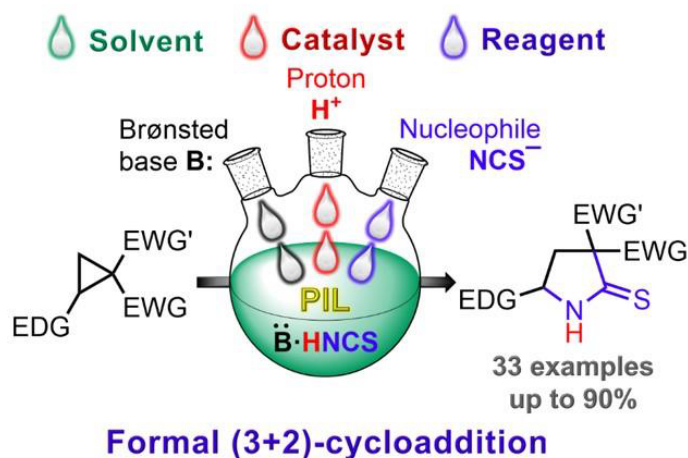
<sup>2</sup>N.D. Zelinsky Institute of Organic Chemistry, Russian Academy of Sciences, Moscow, Russia

<sup>3</sup>M.V. Lomonosov Moscow State University, Department of Chemistry, Moscow, Russia  
Young Scientist

[ivan.andreev@fccho-moscow.ru](mailto:ivan.andreev@fccho-moscow.ru)

Modern demands of synthetic chemistry require the selection of reaction conditions providing both high yields of the target products due to high chemo-, regio-, and stereoselectivity of the processes employed and conformity with the fundamental principles of green chemistry. One of the most attractive solutions to fulfill these criteria while designing new organic transformations lies in utilizing protic ionic liquids (PILs), i.e., low-melting salts of Brønsted acid and base. On the one hand, PILs can pursue a threefold role serving cooperatively as: a) an excellent reaction medium, dissolving both hydrophobic and hydrophilic molecules, b) process initiator *via* acid-base catalysis, and c) reagent, if the PIL contains highly nucleophilic species, red-ox agent, *etc.* On the other hand, PILs can be easily recycled and employed repeatedly, satisfying environmental demands.

The efficiency of this novel concept of the triple role of protic ionic liquids with nucleophilic anions was demonstrated using thiocyanate-based PILs for the ring-opening of donor-acceptor (D-A) cyclopropanes [1]. A wide variety of activated cyclopropanes were found to react with 1-methylimidazolium thiocyanate (HMimNCS) under mild metal-free conditions *via* unusual nitrogen attack of the ambident thiocyanate ion on the electrophilic center of the three-membered ring affording pyrrolidine-2-thiones bearing donor and acceptor substituents at the C(5) and C(3) atoms, respectively, in a single time-efficient step. 1-Methylimidazolium thiocyanate was selected as an appropriate PIL possessing an almost perfect balance of acid-base properties of components forming this reagent that can be regarded as a bench-stable surrogate of isothiocyanic acid.



**Figure 1.** Triple role of thiocyanate-containing protic ionic liquids in ring-opening of D-A cyclopropanes.

The developed procedure can be scaled up without the loss of efficiency and sustainability. Moreover, unreacted HMimNCS can be readily recovered. In particular, the transformation outcome was not affected after 4 cycles of regeneration, the yield of regenerated PIL being close to quantitative. Finally, the ability of 1-methylimidazolium thiocyanate to serve as a triplex reagent was exemplarily illustrated by (4+2)-annulation with 1-acyl-2-(2-hydroxyphenyl)cyclopropane, epoxide ring-opening, and other organic transformations.

## References

[1] Andreev I.A., Ratmanova N.K., Augustin A.U., Ivanova O.A., Levina I.I., Khrustalev V.N., Werz D.B., Trushkov I.V. *Angew. Chem. Int. Ed.* **2021**, *60*, 7927–7934

Acknowledgements. This work was supported by the Russian Foundation for Basic Research (project No 20-33-70014).

REACTIONS OF DONOR-ACCEPTOR CYCLOPROPANES WITH HYDRAZINES: SYNTHESIS OF 5- AND 6-MEMBERED AZAHETEROCYCLES

*Anisovich K.V.*<sup>1</sup>, *Rybakov V.B.*<sup>1</sup>, *Trushkov I.V.*<sup>2</sup>, *Ivanova O.A.*<sup>1</sup>

<sup>1</sup>Moscow State University, Department of Chemistry, Moscow, Russia

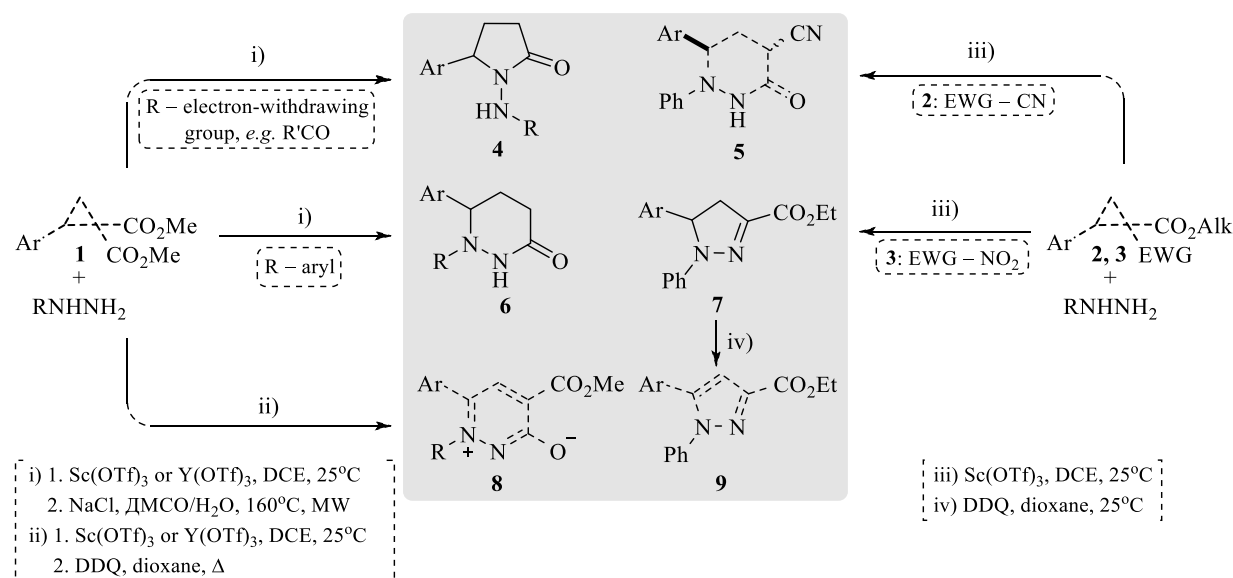
<sup>2</sup>N.D. Zelinsky Institute of Organic Chemistry Russian Academy of Sciences, Moscow, Russia

Student

[anisovich9@gmail.com](mailto:anisovich9@gmail.com)

One of the most important problems of modern organic chemistry is the search for new methods for synthesis of various azaheterocyclic compounds [1-2]. This work is focused on the study of reactions of hydrazines with donor-acceptor cyclopropanes (DAC) containing various electron-withdrawing groups and development of convenient selective methods for the synthesis of azaheterocycles.

The Lewis acid-catalyzed reaction of DAC with hydrazines leads to the formation of 1-aminopyrrolidones **4** or tetrahydropyridazin-3-ones **5**, **6**. The selectivity of the process is controlled by the nature of the substituents in the three-membered ring and hydrazine. Thus, the reaction of substrates **1** and **2** with arylhydrazines leads to the formation of six-membered rings **5**, **6**, while using hydrazines, in which one nitrogen atom is deactivated by an acyl group or another effective electron acceptor, 1-aminopyrrolidones **4** are formed. On the contrary, the reaction of arylhydrazines with 1-nitrocyclopropanecarboxylates **3** leads to substituted dihydropyrazoles **7** as a result of the domino process, including the elimination of the nitro group similar to the Nef reaction. The aromatization of compounds **7** under treatment with DDQ affords pyrazoles **9**. Moreover, mesoionic compounds **8** were synthesized by two-step sequence including the reaction of **1** with hydrazine and the oxidation of products with DDQ (Fig. 1).



**Figure 1.** The Lewis acid-catalyzed reaction of DAC with hydrazines.

**References**

- [1] Singh P., Varshnaya R. K., Dey R., Banerjee P. *Adv. Synth. Catal.* **2020**, *362*, 1447–1484  
 [2] Andreev I. A., Ratmanova N. K., Augustin A. U., Ivanova O. A., Levina I. I., Khrustalev V. N., Werz D. B., Trushkov I. V. *Angew. Chem., Int. Ed.* **2021**, *60*, 792–934

Acknowledgements. This work was supported by the Russian Science Foundation (project No 21-73-20095).

# SYNTHESIS OF 2-METHYLIDENEPYRROL-3-ONES FROM DIYNONES AND AMINES

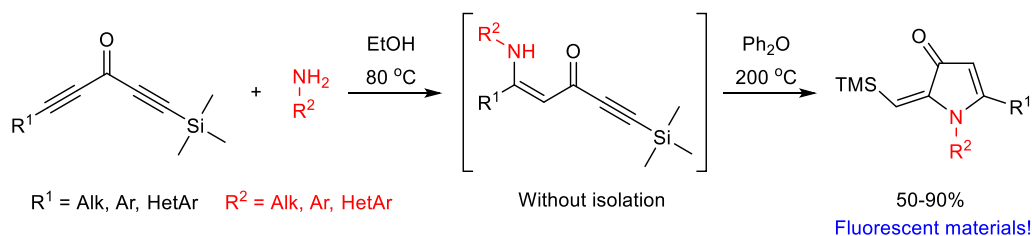
*Antonov N.S.<sup>1</sup>, Pankova A.S.<sup>1</sup>, Golubev P.R.<sup>1</sup>*

<sup>1</sup>Saint Petersburg State University, Saint Petersburg, Russia

1<sup>st</sup> year student

st086331@student.spbu.ru

Addition of various nitrogen-containing nucleophiles to an *alpha,beta*-unsaturated carbonyl compound is a common approach to construction of a plethora of *N*-heterocycles (such as pyrazoles, pyrimidines *etc.*). For example, we have previously shown that cross-conjugated enynones can be coupled with various binucleophiles to obtain alkynylated pyrazoles, pyrimidines and pyrazolo[1,5-*a*]pyrimidines [1-3]. On the other hand, in case of amines, 4-substituted 2-methylidenepyrrolones were obtained [4]. Some of these compounds were found to be fluorescent, with fluorescence heavily depending on the substitution pattern of the pyrrolone. Due to our interest in synthesis of novel fluorescent materials, we sought to investigate the methylenepyrrolone scaffold more thoroughly, and envisioned that isomeric compounds could be synthesized from diacetylenic ketones and amines.



**Figure 1.** Principal synthetic plan

Surprisingly, this reaction has not been studied thoroughly in the past. Heating of symmetrical diarylpentadiynones with amines is known to yield mixtures of isomeric pyrrolones and pyridones; on the contrary, 4-pyridones were obtained exclusively in case of dialkyldiynones [5]. A NIS-promoted cyclization of diynones with amines was also reported, but for some reason this reaction had a very limited scope with regard to amines [6].

In our work, we focused on the use of monosilylated diynones, since the silyl group appears to direct the cyclization step towards 5-*exo-dig* mode. We have studied the reaction with a wide range of amines and are currently working on maximization of the diynone scope. Our preliminary results showed the reaction to be regioselective and high-yielding and were recently published [7].

In current presentation, a more detailed insight into reaction scope will be provided with more synthetic details, as well as the fluorescence data.

## References

- [1] A.S. Pankova, P.R. Golubev, I.V. Ananyev, M.A. Kuznetsov *Eur. J. Org. Chem.* **2012**, 5965–5971
- [2] P.R. Golubev, A.S. Pankova, M.A. Kuznetsov *Eur. J. Org. Chem.* **2014**, 3614–3621
- [3] P. Golubev, E. A. Karpova, A.S. Pankova, M. Sorokina, M.A. Kuznetsov *J. Org. Chem.* **2016**, *81*, 11268–11275
- [4] P.R. Golubev, A.S. Pankova, M.A. Kuznetsov *J. Org. Chem.* **2015**, *80*, 4545–4552
- [5] T. Metler, A. Uchida, S. I. Miller *Tetrahedron* **1968**, *24*, 4285-4297
- [6] Y.-F. Qiu, F. Yang, Z.-H. Qiu, M.-J. Zhong, L.-J. Wang, Y.-Y. Ye, B. Song, Y.-M. Liang *J. Org. Chem.* **2013**, *78*, 12018-12028.
- [7] A.S. Pankova, N.D. Cherepanova, P. Golubev, M.A. Kuznetsov *Chem. Heterocycl. Comp.* **2019**, *55*, 672-675.

Acknowledgements: NMR and MS analyses were performed at the Research park of St. Petersburg State University «Center for Magnetic Resonance» and «Center for Chemical Analysis and Materials Research».

# NEW PARADIGM IN HYPERVALENT IODINE CHEMISTRY: ELECTROCATALYTIC OXIDATIVE C–N COUPLING

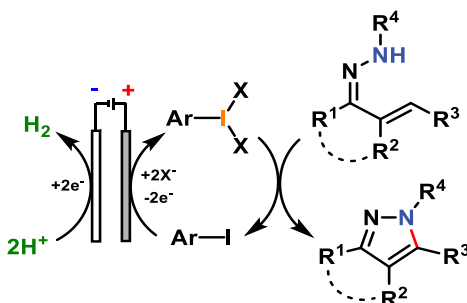
*Antonova L.S.<sup>1</sup>, Paveliev S.A.<sup>1</sup>, Terent'ev A.O.<sup>1</sup>*

<sup>1</sup>N. D. Zelinsky Institute of Organic Chemistry of the Russian Academy of Sciences, Moscow, Russia  
Student

[liliyaalimhanova1998@mail.ru](mailto:liliyaalimhanova1998@mail.ru)

Cross-dehydrogenative coupling and C–H functionalization with C–N bond formation are currently one of the most actively developing areas of modern organic synthesis [1]. Being the successor to the traditional cross-coupling, oxidative coupling allows one to selectively combine molecules of interest for the minimum number of synthetic stages, seeming to be the most direct, atom-efficient and sustainable method of creating a C–N bonds. Using oxidative C–N coupling methodology, a huge number of approaches to the synthesis of important N-heterocyclic compounds and biologically active molecules containing C–N bonds in their structure have been created [2]. The successful outcome of the oxidative C–N coupling largely depends on the choice of an appropriate oxidizing agent, which would selectively activate often different in nature C–H and N–H bonds. The approach using hypervalent iodine compounds is highly selective, easy to carry out and has a wide range of suitable substrates [3]. However, implementation of hypervalent iodine-based oxidants is associated with the formation, and, consequently, with the need to dispose of stoichiometric amounts of waste, which imposes restrictions on the scaling of the synthesis.

As an affordable and environmentally friendly alternative to hypervalent iodine and other traditional oxidizing agent, electric current is becoming increasingly common as a reliable tool for conducting oxidative coupling, including creation of C–N bonds and synthesis of N-heterocyclic compounds [4]. Along with obvious advantages, the main limitations of the electrochemical methodology is the difficulty in maintaining selectivity due to the potential possibility of overoxidation of starting reagents, and, in this regard, the scope of substrates, applicable for selective electrochemical oxidative C–N coupling, remains sufficiently narrow. The new phase of development, which inherits the merits of the approaches described above, and at the same time seeks to overcome their limitations, is oxidative coupling using electrochemically generated hypervalent iodine compounds [5].



**Figure 1.** Electrocatalytic oxidative C–N coupling.

The electrochemical hypervalent iodine catalyzed cross-dehydrogenative C(sp<sup>2</sup>)-H/N–H coupling of  $\alpha,\beta$ -unsaturated hydrazones resulting substituted pyrazoles has been discovered. The process is based on the in-cell generation of hypervalent iodine species through continuous anodic oxidation of aryl iodide catalyst in fluorinated alcohol. The formation of hypervalent iodine compounds and their key role in the creation of a new C–N bond was confirmed with the use of CV and NMR experiments. A wide range of substituted pyrazoles was obtained in yields up to 88%. The present work deals with fundamentally important areas of modern organic chemistry such as methodology of oxidative C–N coupling, preparative electroorganic synthesis and electrochemistry of hypervalent iodine compounds.

## References

- [1] Wei W., et. al. *Org. Lett.* **2018**, *20*, 7125-7130
- [2] Li H., et. al. *Green Chem.* **2020**, *22*, 582-611
- [3] Watanabe K., Moriyama K. *Molecules* **2019**, *24*, 1147
- [4] Kärkäs M. D. *Chem. Soc. Rev.* **2018**, *47*, 5786-5865
- [5] Francke R. *Curr. Opin. Electrochem.* **2019**, *15*, 83-88

Acknowledgements. This work was supported by the Russian Science Foundation (grant № 21-13-00205).

RESEARCH OF PROPERTIES AND BIOLOGICAL ACTIVITY OF P-, S- DERIVATIVES OF HINDERED PHENOLS

*Apalkova E.A., Bulygina A.V., Kuzmina A.V., Pistsova A.L., Shamsutdinova L.P., Gazizov M.B.*

Kazan National Research Technological University, Kazan, Russia

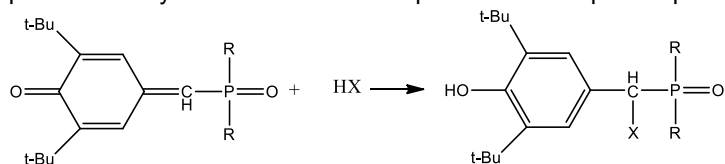
Student

[Apalkovakaty1306@mail.ru](mailto:Apalkovakaty1306@mail.ru)

Nowadays a lot of biomedical and chemical data is collected. They are used at the stage of planning the synthesis of drugs [1].

The investigation of synthesis and properties of hindered phenols functionalized by different groups is actual. This is related to the possibility of extending the spectrum of biological activity and increasing the efficiency of their applied properties.

The synthesis of organosulfur-sulfur derivatives of spatially hindered phenols is based on the high nucleophilic reactivity of bivalent sulfur compounds with respect to phosphorylated methylenequinones [4, 5].



1, 2, 3, 4, 5

1.1 - 1.4, 2.1 - 2.4,

3.1 - 1.4, 4.1 - 2.4,

5.1 - 5.4

**Table 1:** Table of space-hindered phenols investigated

№ n/n	Compound number	R	X	№ n/n	Compound number	R	X
1	1	Me	-	14	3.3	Ph	-SPh
2	1.1	Me	-SC(O)CH <sub>3</sub>	15	3.4	Ph	-S-(i-Pr)
3	1.2	Me	-SC(O)Ph	16	4	OMe	-
4	1.3	Me	-SPh	17	4.1	OMe	-SC(O)CH <sub>3</sub>
5	1.4	Me	-S-(i-Pr)	18	4.2	OMe	-SC(O)Ph
6	2	Et	-	19	4.3	OMe	-SPh
7	2.1	Et	-SC(O)CH <sub>3</sub>	20	4.4	OMe	-S-(i-Pr)
8	2.2	Et	-SC(O)Ph	21	5	OEt	-
9	2.3	Et	-SPh	22	5.1	OEt	-SC(O)CH <sub>3</sub>
10	2.4	Et	-S-(i-Pr)	23	5.2	OEt	-SC(O)Ph
11	3	Ph	-	24	5.3	OEt	-SPh
12	3.1	Ph	-SC(O)CH <sub>3</sub>	25	5.4	OEt	-S-(i-Pr)
13	3.2	Ph	-SC(O)Ph				

We carried out computer prediction of some physico-chemical properties, which are important for pharmacology, using the service of the way2drug.com platform and the program AIOGPS.

The data obtained allow us to conclude about the different, but rather low solubility in water of the studied compounds.

Using the GUSAR software it is possible to determine the toxicity of compounds for rats.

In the course of work, we made a prediction of biological activity using the PASS program. We selected prediction data of antioxidant, antiradical, antitumor, and nootropic activities for analysis.

According to the data obtained, most spatially hindered phenols exhibit reducing properties and can exhibit antioxidant activity, can inhibit lipid peroxidation processes and act as "traps" of free radicals. This makes it possible to consider these compounds as potential agents for the therapy of oxidative stress. Compounds that do not contain a carbonyl group may exhibit nootropic activity.

#### References

[1] Gazizov M.B., Ismagilov R.K., Pistsova A.L., Tikhonova N.S., Shamsutdinova L.P., Burangulova R.N., Karimova R.F. Synthesis and properties of some S-containing derivatives of phosphorylated spatially hindered phenols // *Journal of General Chemistry*. 2017. T. 87. № 12. C. 2080-2083.

[2] Gazizov M.B., Pistsova A.L., Ismagilov R.K., Shamsutdinova L.P., Karimova R.F., Burangulova R.N. The interaction of phosphorylated 4-methylene-2,6-di-tert-butylcyclohexadiene-2,5-ones with aliphatic, aromatic and heteroaromatic phenols // *Journal of General Chemistry*. 2017. T. 87. № 5. C. 876-878.

# SYNTHESIS OF PHOTOCLEAVABLE PORPHYRIN-COMBRETASTATIN CONJUGATES FOR COMBINED THERAPY OF CANCER

*Kuzmina N.S.<sup>1</sup>, Otvagin V.F.<sup>1</sup>, Maleev A.A.<sup>1</sup>, Nyuchev A.V.<sup>1</sup>, Fedorov A.Yu.<sup>1</sup>*

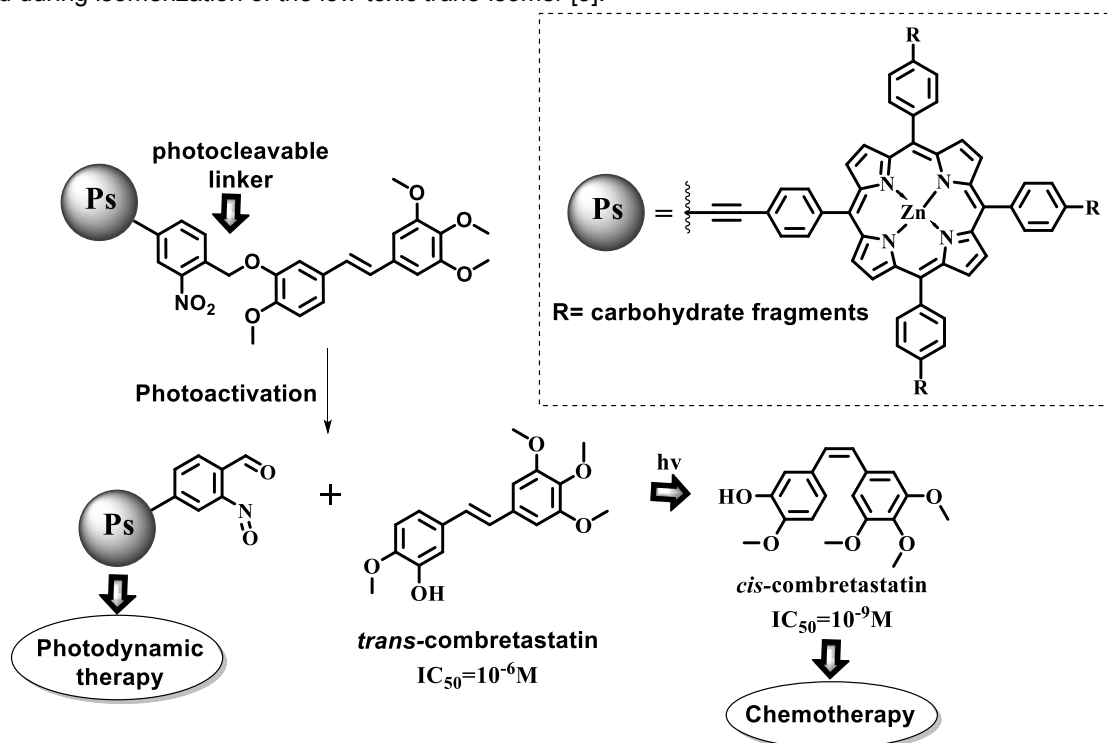
<sup>1</sup>N.I. Lobachevsky State University of Nizhny Novgorod, Nizhny Novgorod, Russia

PhD student

[kuzmina.ns2014@gmail.com](mailto:kuzmina.ns2014@gmail.com)

The multidrug resistance of tumors and significant general toxicity are the main problems of modern chemotherapy [1]. The first problem can be solved using combination therapy approaches. The general way to reduce the systemic toxicity of drugs is the use of their prodrug forms.

In this work new hybrid photoactive conjugates consisting of a synthetic porphyrin photosensitizer (Ps), a photocleavable linker, a therapeutic agent (combretastatin A4), and carbohydrates were synthesized [2]. The *o*-nitrobenzyl linker binds the *trans*-combretastatin in an inactive form and releases it upon light irradiation (Fig. 1). Also, the action of light makes it possible to activate the chemotherapeutic drug, *cis*-combretastatin A4, which is formed during isomerization of the low-toxic *trans*-isomer [3].



**Figure 1.** The conception of photocleavable conjugates

For synthesized conjugates photophysical characteristics were investigated and theoretical calculations were performed.

## References

- [1] Dumontet C., Jordan M. A., *Nat. Rev.*, **2010**, 9, 790-803.
- [2] Kuzmina N.S., Otvagin V. F., Krylova L. V., Nyuchev A. V., Romanenko Y. V., Koifman O. I., Balalaeva I. V., Fedorov A. Yu. *Mendeleev Commun.* **2020**, 30(2), 159-161.
- [3] Scherer K. M., Bisby R. H., Botchway S. W., Hadfield J. A., Parker A. W. *J. Biomed. Opt.*, **2015**, 20(5), 051004-1 – 051004-6.



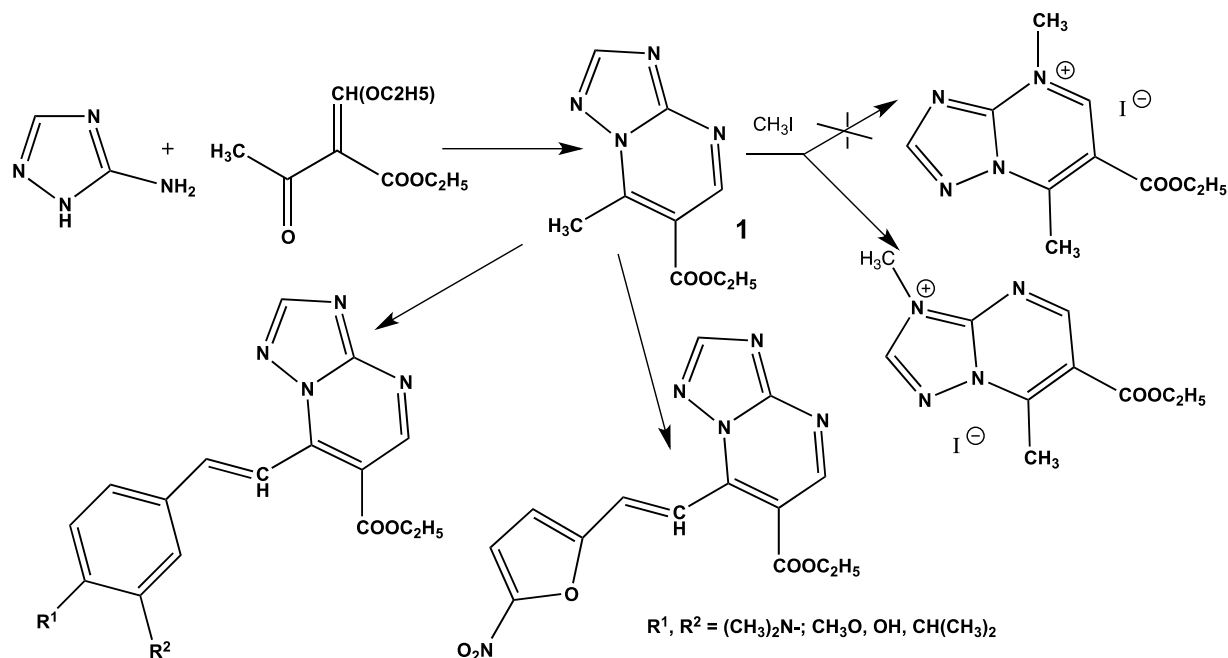
SYNTHESIS OF PUSH-PULL SYSTEMS BASED ON 1,2,4-TRIAZOLO[1,5-a]PYRIMIDINE

*Arakelyan M.R.<sup>1,2</sup>, Danagulyan A.G.<sup>1,2</sup>, Danagulyan G.G.<sup>1,2</sup>*

<sup>1</sup>Russian–Armenian (Slavonic) University, Yerevan, Armenia  
gdanag@email.com

<sup>2</sup>Technological Center of Organic and Pharmaceutical Chemistry, National Academy of Sciences of the Republic of Armenia, Yerevan, Armenia;  
meline.aragelyan.1993@mail.ru  
Ph.D. Student

The reaction of 3-amino-1,2,4-triazole with ethoxymethylenacetacetic ester resulted in the synthesis of 7-methyl-6-ethoxycarbonyl-1,2,4-triazolo[1,5-a]pyrimidine. It was shown that its alkylation with methyl iodide proceeded exclusively at the nitrogen atom of N4 of the triazole ring leading to the production of 4,7-dimethyl-6-ethoxycarbonyl-1,2,4-triazolo[1,5-a]pyrimidine iodide. This was proved by the NMR spectra using the NOESY technique.



**Figure 1.**

By the reaction of triazolopyrimidine 1 with various aromatic aldehydes that contained electron-donating substituents in the benzene ring, polyconjugated heteroaromatic systems were synthesized. They can be regarded as push-pull systems that potentially have the properties of organic semi-conductors. It is also planned to study the antiviral activity of the synthesized models, as well as a number of hybrid systems on their basis.

*Acknowledgements. This work was carried out with the financial support of the State Committee on Science of the Republic of Armenia and the Russian Foundation for Basic Research (project 20RF-138 / 20-53-05010 Arm\_a /), as well as within the framework of the grant of the Ministry of Education and Science of the Russian Federation for scientific research of the Russian-Armenian University.*

# UTILIZING O-QUINONE METHIDE CHEMISTRY: SYNTHESIS OF STERICALLY HINDERED CATECHOLS, QUINONES AND ACRIDIN-4-OLS

Arsenyev M.V.<sup>1</sup>, Zhiganshina E.R.<sup>1</sup>, Chesnokov S.A.<sup>1</sup>

<sup>1</sup> G. A. Razuvaev Institute of Organometallic Chemistry,  
Nizhny Novgorod, Russia.  
Young scientist, PhD  
[mars@iomc.ras.ru](mailto:mars@iomc.ras.ru)

o-Quinonemethide is popular intermediate for the synthesis of new phenols, heterocyclic compound and other. Earlier we reported the multigram scale synthesis of 3,5-di-tert-butyl-6-methoxymethylcatechol [1]. This compound can act as a source of sterically hindered o-quinone methide in the alkylation of alcohols, heterocycles [2], thiols as well as activated arenes [3]. It has been used to obtain new inhibitors and initiators of radical processes.

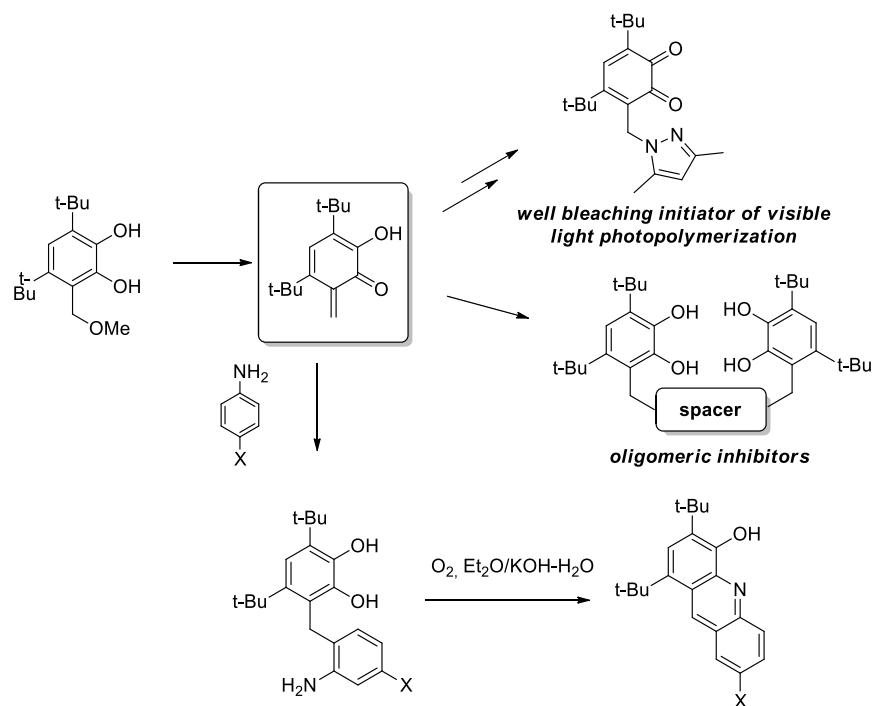


Figure 1. Reaction.

Also, we have demonstrated that alkylation of anilines by 3,5-di-tert-butyl-6-methoxymethylcatechol in toluene leads to the formation (anilinomethyl)catechols. Formation of the acridine moiety was found to occur in the course of oxidation of the intermediate (anilinomethyl)catechol [4].

## References

- [1] Arsenyev M.V., Baranov E.V., Shurygina M.P., Chesnokov S.A., Abakumov G.A.. *Mendeleev Commun.*, **2016**, 26, 552.
- [2] Poddel'sky A.I., Arsenyev M.V., Astaf'eva T.V., Chesnokov S.A., Fukin G.K., Abakumov G.A. *J. Organomet. Chem.*, **2017**, 835, 17.
- [3] Arsenyev M.V., Astaf'eva T.V., Baranov E.V., Poddel'sky A.I., Chesnokov S.A. *Mendeleev Commun.*, **2018**, 28, 76.
- [4] Polyakova S.K., Balashova T.V., Rumyantsev R.V., Arsenyev M.V., Fukin G.K., Chesnokov S.A.. *Mendeleev Commun.*, **2021**, 31, 262.

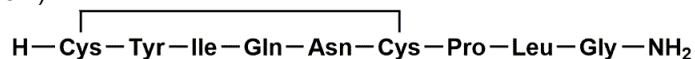
Acknowledgements. This work was supported by the Russian Science Foundation (project No 19-73-10173).

## STUDY OF THE CYCLIZATION OF OXYTOCIN AND DESAMINOXYTOCIN IN THE SOLID SUPPORT

*Avdeev D.V.<sup>1</sup>, Ovchinnikov M.V.<sup>1</sup>, Molokoedov A.S.<sup>1</sup>, Sidorova M.V.<sup>1</sup>*

<sup>1</sup>FSBI "National Medical Research Cardiological Center" of Russian Health Ministry, Moscow, Russia  
[peptides.dv@gmail.com](mailto:peptides.dv@gmail.com)

Oxytocin (OT) is a neurohypophyseal hormone with a broad spectrum of biological activity, consisting of 9 amino acid residues (Figure 1).



**Figure 1.** Structural formula of Oxytocin

On the basis of Oxytocin, preparations were created that are in demand in gynecology - Atosiban and Carbetocin. Desaminoxytocin (DOT) is also a drug used in gynecology. The widespread use of OT analogs in clinical practice prompted us to study in detail its synthesis in order to develop a large-scale technique that can be used to obtain any of the analogs with a similar structure.

We carried out a solid phase synthesis (SPPS) of these peptides on a Rink amide polymer using the Fmoc- methodology. Due to the fact that OT and DOT are cyclic disulfides, the fundamental stage in their synthesis is the creation of a disulfide bond. To circumvent the problem of high dilutions observed during oxidation in solution and to reduce the formation of by-products, as well as to simplify the isolation of target compounds, we decided to close the S-S bridge on the polymer. Since these peptides do not contain tryptophan residues in their structure, we chose  $J_2$  as an oxidizing agent, since it is readily soluble in organic solvents that provide good solvation of the peptidyl polymer, and when it is used, a direct conversion of the cysteine-protected peptide into a cyclic disulfide occurs. We have shown that when using different excess  $J_2$ , the amount of non-cyclic products is different. A comparative assessment of the results of the cyclization of OT and DOT (see table) showed an essential role of the status of the N-terminal amino group in the corresponding peptidyl polymers. It was noted that in the presence of an unsubstituted amino group, the content of the target disulfide in the cyclization products is much lower than in the case of the deamino analog or Boc-protected intermediate due to the higher formation of dimers and by-products at the free  $-\text{NH}_2$  group. The data obtained by us open up wide opportunities for the development of a large-scale method for the synthesis of preparations such as Desaminoxytocin, Atosiban, Vasopressin, Terlipressin, Desmopressin, Ornipressin and Felipressin.

**Table.** Influence of the conditions for closing the S-S bridge by the action of  $J_2$  on the content of the target and by-products in the reaction mixture during the cyclization of Oxytocin and Desaminoxytocin in the solid support.

№	Peptide name	Status of the N-terminal amino group on the polymer	Excess $J_2$	Composition of the reaction mixture by HPLS, %		
				S-S peptide	SH-peptide	Dimers
1	Oxytocin	BocNH-	1.5	57.56	13.07	<8
2	Oxytocin	H <sub>2</sub> N-		20.46	44.13	>10
3	Desaminoxytocin	-		83.80	6.01	6.21
4	Oxytocin	BocNH-	3	85.4	<1.0	<10
5	Oxytocin	H <sub>2</sub> N-		51.91	18.56	>10
6	Desaminoxytocin	-		93.52	1.06	4.47
7	Oxytocin	BocNH-	10	86.28	<1.0	<10
8	Oxytocin	H <sub>2</sub> N-		41.8	6.85	>10
9	Desaminoxytocin	-		51.45	31.59	4.71

# SYNTHESIS AND BIOASSAY OF 6-HALOCINNOLINONES AS POTENTIAL PTP1B INHIBITORS

*Babushkina A.A.*<sup>1</sup>, *Mikhaylov V.N.*<sup>1</sup>, *Novikov A.S.*<sup>1</sup>,  
*Zakharova I.O.*<sup>2</sup>, *Shpakov A.O.*<sup>2</sup>

<sup>1</sup>Saint Petersburg State University, Saint Petersburg, Russia

<sup>2</sup>Sechenov Institute of Evolutionary Physiology and Biochemistry, St. Petersburg, Russia

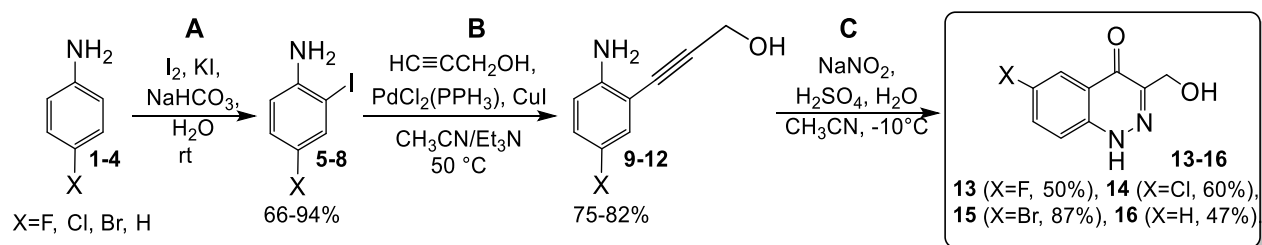
Master's degree student

[babushkina.nastya@yandex.ru](mailto:babushkina.nastya@yandex.ru)

According to the International Diabetes Federation (IDF) Diabetes Atlas data, diabetes currently affects an estimated 463 million people in the world in 2019, and if this trend continues, this will rise to 700 million by the end of 2045[1].

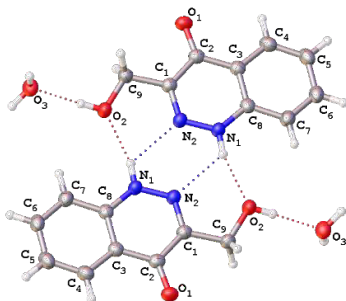
The protein tyrosine phosphatase 1B (PTP1B) is a negative regulator of insulin signaling. PTP1B inhibitors increase the phosphorylation of insulin receptor and make the cell responsive to insulin for glucose uptake. Thus, PTP1B has considered a promising therapeutic target for the treatment of type 2 diabetes [2].

The 6-halocinnolinones were selected based on the docking results and the accepted pharmacophore model. Compounds **13-16** were obtained by modified literature methods [3] (Figure 1).

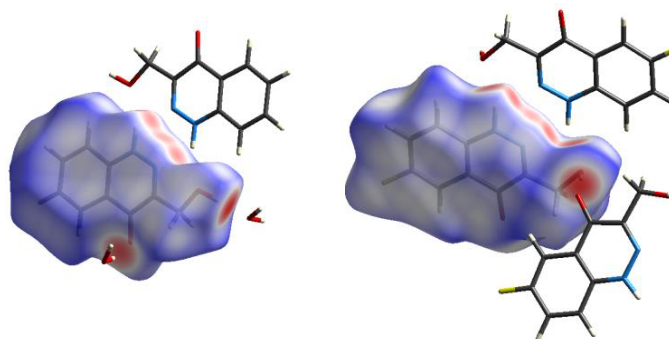


**Figure 1.** Synthesis of target 6-halocinnolinones **13-16**

Compounds **13** and **16** were characterized by single-crystal X-ray diffraction. Non-covalent interactions in crystals **13** and **14** were studied by DFT.



**Figure 2.** Dimer in crystal **16**



**Figure 3.** Hirshfeld surfaces for **16** (left) and **13** (right)

*In vivo* studies have shown that compounds **14** and **15** decrease food intake and body weight after 5 days of treatment. In addition, a decrease in the concentration of insulin and leptin in the blood was observed. The expression of the PTP1B gene is increased in the groups of rats treated with inhibitors, which indicates the suppression of the enzyme activity by both compounds and proves that their target is PTP1B.

## References

- [1] International Diabetes Federation. *IDF Diabetes Atlas, 9th edn.* Brussels, Belgium: 2019. Available at: <https://www.diabetesatlas.org>
- [2] Dowarah J., Singh V.P. *Bioorg. Med. Chem.* **2020**, *58*, 115263
- [3] Mikhaylov V. N. et al. *Chem. Heterocycl. Compd.* **2020**, *56*(7), 915

Acknowledgements. This work was supported by the Russian Science Foundation (project No 19-73-00228). The work was also performed by equipment of SPbU Research Park: RC MRR, RC XRD, RC CAMR.

# ANTIBACTERIAL ACTIVITY OF CALCIUM PHOSPHATE WITH THE ADDITION OF ANTIBIOTICS

*Badretdinova V.T.*<sup>1</sup>, *Serykh T.A.*<sup>2</sup>

<sup>1</sup>ITMO University, Saint Petersburg, Russia

<sup>2</sup>ITMO University, Saint Petersburg, Russia

Student

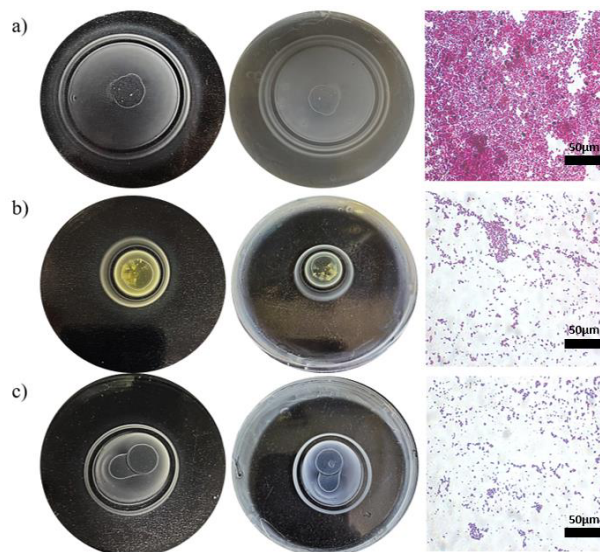
[badretdinova@infochemistry.ru](mailto:badretdinova@infochemistry.ru)

In reconstructive and reconstructive surgery, local bacterial infection is a complication and can lead to adverse treatment outcomes. Treatment of these complications occurs by surgical intervention, elimination of all foreign bodies from the focus of infection and systemic antibiotic therapy to prevent the risk of contracting a new infection [1].

However, long-term use of antibiotics can lead to the development of unwanted adverse reactions in patients. At the same time, to obtain the required concentration of an antibacterial substance in the focus of infection, high doses of antibiotics are required with constant use, which leads to toxic reactions in the body. In addition, even higher doses of antibiotics may not be sufficient for local bactericidal action on microorganisms.

Despite the improvement of treatment methods, surgical techniques and the emergence of new highly active antibiotics, the recurrence rate remains high, and the treatment of infectious complications of bone and soft tissues continues to be an important task. Therefore, there is a need to create a new system that will have an antibacterial effect and deliver drugs locally [2].

In the process of research, calcium-phosphate systems were obtained with loaded antibiotics with varying concentrations. The concentrations of gentamicin and tetracycline were varied from 0.1 mg / ml to 10 µg / ml. Antibacterial activity was evaluated using the example of the bacterium *Staphylococcus aureus*. The samples were kept for two days, and then the growth and zones of inhibition of bacterial activity were observed. After that antibacterial calcium phosphate samples stained with Gram's method.



**Figure 1.** a) Control before and after sowing *Staphylococcus aureus*, stained with methyl violet; b) samples with tetracycline at a concentration of 0.01 mg / ml before and after sowing *Staphylococcus aureus*, stained with methyl violet; c) samples with gentamicin at a concentration of 0.001 mg / ml before and after inoculation of *Staphylococcus aureus*, stained with methyl violet

It was revealed that samples with tetracycline at a concentration of 0.01 mg / ml and with gentamicin at a concentration of 0.001 mg / ml have inhibitory properties against the bacterium *Staphylococcus aureus*, while on the same samples C2C12 cell cultures can grow for 8 days with a density of 600-800 cells / mm<sup>2</sup>. Therefore, these systems can be used as model systems for creating antibacterial coatings on implants.

## References

- [1] Lotsari, A. *Nat. Comm.* **2018**, 9, 4170.
- [2] Pandey A. *Electronic* **2018**, 191, 1873
- [3] Park H. K., Lee, S.J. *Nanoscale Res. Lett.* **2015**, 10, 981

Authors acknowledge RSF grant no. 19-79-10244 for the financial support. ITMO Fellowship and Professorship Program 08-08 is acknowledged for infrastructural support.

# KINETIC STUDY OF PROPYLENE-FORMALDEHYDE CONDENSATION OVER THE H-BEA ZEOLITE CATALYST

*Bedenko S.P.<sup>1</sup>, Dement'ev K.I.<sup>1</sup>, Tret'yakov V.F.<sup>1</sup>*

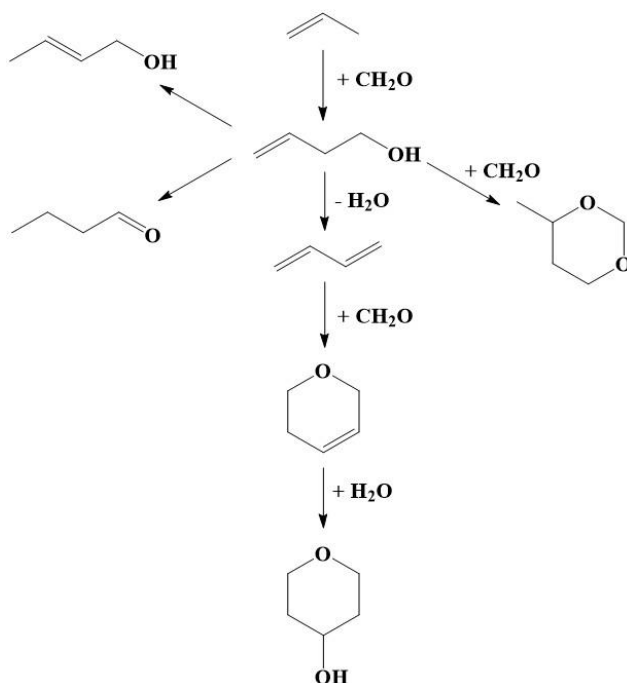
<sup>1</sup>A.V. Topchiev Institute of Petrochemical Synthesis RAS, Moscow, Russia

PhD student

[bedenko@ips.ac.ru](mailto:bedenko@ips.ac.ru)

The olefin-formaldehyde Prins condensation is a very promising and effective road to obtain  $\gamma$ -unsaturated alcohols and oxygenated heterocycle compounds, which are used as industrial precursors for diene synthesis. Traditionally, strong mineral acids, such as sulfuric and orthophosphoric acids, or Lewis acids, such as  $\text{ZnCl}_2$ ,  $\text{SnCl}_4$ , are used as the reaction catalyst. It is known, such types of catalysts have significant ecological drawbacks, such as extremal corrosivity, pure selectivity control and non-renewability. These problems can be solved by using heterogeneous catalysts, in particular zeolites [1-3].

One of the most promising zeolites for this aim is the BEA-type. According to [3-4], H-BEA zeolites is very reactive catalyst for the propylene and isobutene Prins condensation with formaldehyde, however reaction product consists of many compounds, such as substituted 1,3-dioxanes, 3-butenols-1, dihydro-2H-pyrans and 4-hydroxy-tetrahydropyrans. Moreover, there is no information about reaction mechanism and selectivity control studies of this reaction over zeolites. In view of these reasons, we carried out kinetic study of propylene-formaldehyde condensation over H-BEA zeolite catalyst in 1,4-dioxane medium at 120-180°C.



**Figure 1.** Reaction scheme.

Curves of reagents and products concentration changing were obtained and analyzed. The reaction mechanism and their mathematical model were purposed according to obtained data. The model parameters were also estimated. According to obtained model, formaldehyde activation is a first-order step with observed  $E_a = 26.97 \pm 0.45$  kJ/mol, propylene activation is a pseudo-zero-order step with observed  $E_a = 22.54 \pm 0.38$  kJ/mol; 3-butenol-1 synthesis proceed via tandem formaldehyde and propylene activation with observed  $E_a = 49.51 \pm 0.83$  kJ/mol, while 4-methyl-1,3-dioxane are produced via cascade of steps (formaldehyde activation, propylene activation, 3-butenol conversion) with observed  $E_a = 61.62 \pm 1.03$  kJ/mol.

## References

- [1] Bedenko S.P. et al. *Petroleum Chemistry* **2020**, *60*, 723-730
- [2] Vasiliadou E.S. et al. *Chemcatchem* **2017**, *9*, 4417-4425
- [3] Vasiliadou E.S. et al. *Catal. Sci. Technol.* **2018**, *8*, 5794-5806.
- [4] Bedenko S.P. et al. *Catal. Commun.* **2020**, *138*, 105965

Acknowledgements. This work was supported by RFBR, project number 20-33-90112.

# INTRAMOLECULAR EXCIMER FORMATION IN STEREOREGULAR TETRAMERIC CYCLOSILOXANES CONTAINING DIBENZOYLMETHANATOBORON DIFLUORIDE

*Belova A.S.*<sup>1</sup>, *Kononevich Yu.N.*<sup>1</sup>, *Ionov D.S.*<sup>2</sup>, *Sazhnikov V.A.*<sup>2</sup>, *Shchegolikhina O.I.*<sup>1</sup>, *Muzafarov A.M.*<sup>1,3</sup>

<sup>1</sup>A.N. Nesmeyanov Institute of Organoelement Compounds of Russian Academy of Sciences, Moscow, Russia

<sup>2</sup>Photochemistry Center, FSRC "Crystallography and Photonics" of Russian Academy of Sciences, Moscow, Russia

<sup>3</sup>N.S. Enikolopov Institute of Synthetic Polymeric Materials of Russian Academy of Sciences, Moscow, Russia

PhD Student

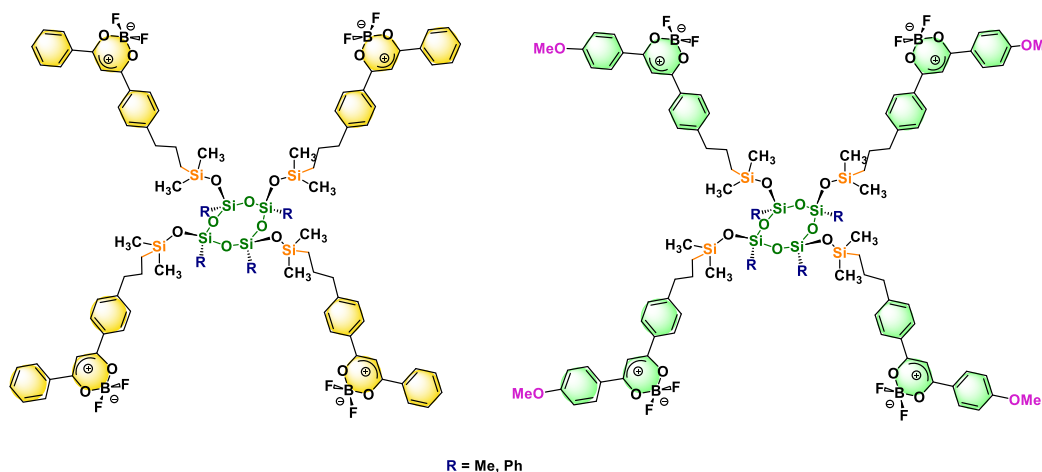
[belova.asya@gmail.com](mailto:belova.asya@gmail.com)

Complexes based on difluoroboron  $\beta$ -diketonate are widely used in various fields. Due to the spectral properties of the complexes in solution and solid state, as well as their ability to self-organize, they find application in devices for biosensors, bioimaging and optoelectronics [1-2]. They are one of the potential fluorophores for creating white organic light emitting diodes (WOLEDs), since they are capable of forming excimers and exciplexes in an excited state.

Difluoroboron  $\beta$ -diketonate derivatives can be used as materials with aggregation-induced emission, mechanochromic and photochromic materials, solar cells, light-harvesting systems, luminescent probes for detection of  $O_2$ , amine and cyanide ion, organic thermometers, pH sensor. Also, the ability of DBMBF<sub>2</sub> derivatives to form exciplexes with aromatic compounds can be successfully used to detect trace amounts of benzene, toluene and xylenes (BTX) vapors [3].

Convenient matrices for fixing fluorophores in order to obtain excimers are linear and stereoregular cyclic siloxanes, which make it possible to arrange several fluorophores in the same plane at a close distance, thus promoting interfluorophore  $\pi$ - $\pi$  interaction and the formation of excimers in an excited state. Earlier, we have obtained dyads based on linear siloxanes of various lengths and DBMBF<sub>2</sub> derivatives [4].

In this work we synthesize four tetrachromophoric dyes based on stereoregular tetrameric cyclosiloxanes containing in their structure various derivatives of dibenzoylmethanato boron difluoride (Figure 1). Fluorescent properties of these compounds were measured in solutions of cyclohexane, dichloromethane, toluene, acetonitrile and ethanol. Also, influence of temperature on the excimer formation was studied.



**Figure 1.** Structure of tetrachromophoric dyes based on stereoregular tetrameric cyclosiloxanes containing dibenzoylmethanato boron difluoride

## References

- [1] K. Tanaka, Y. Chujo, *NPG Asia Mater.* **2015**, 7, e223–e223.
- [2] P.-Z. Chen, L.-Y. Niu, Y.-Z. Chen, Q.-Z. Yang, *Coord. Chem. Rev.* **2017**, 350, 196–216.
- [3] Y. N. Kononevich, V. A. Sazhnikov, A. S. Belova, A. A. Korlyukov, A. D. Volodin, A. A. Safonov, G. A. Yurasik, D. S. Ionov, A. M. Muzafarov, *New J. Chem.* **2019**, 43, 13725–13734.
- [4] Y. N. Kononevich, A. S. Belova, V. A. Sazhnikov, A. A. Safonov, D. S. Ionov, A. D. Volodin, A. A. Korlyukov, A. M. Muzafarov, *Tetrahedron Lett.* **2020**, 61, 152176.

Acknowledgements. This work was supported by the Russian Science Foundation (grant no. 18-73-10152)

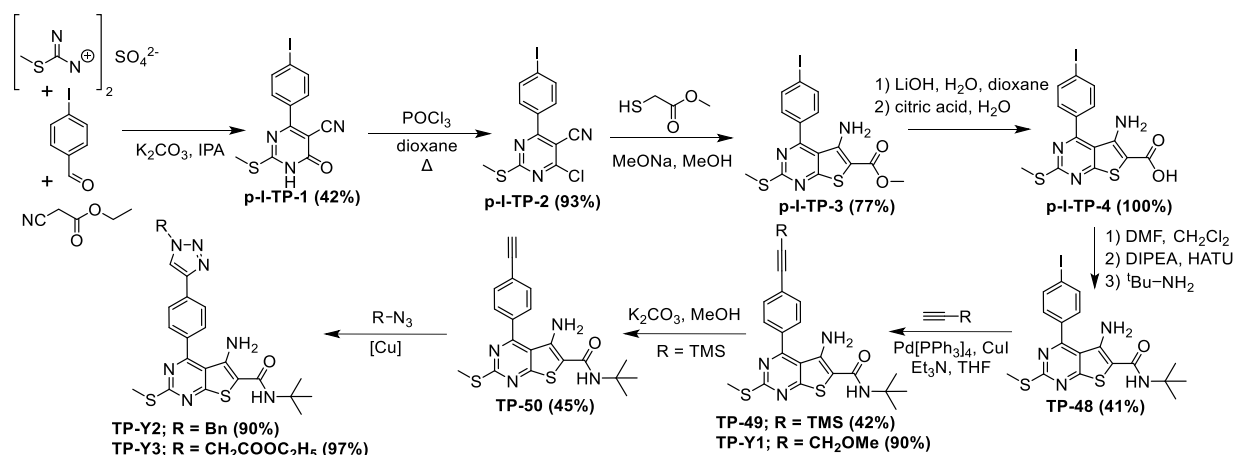
DEVELOPMENT OF APPROACHES TO THE SYNTHESIS OF THIENO[2,3-*d*]PYRIMIDINE DERIVATIVES AS THYROID-STIMULATING HORMONE RECEPTOR TRANSMEMBRANE ALLOSTERIC SITE LIGANDS

*Belysheva M.N.*<sup>1</sup>, *Derkach K.V.*<sup>2</sup>, *Shpakov A.O.*<sup>2</sup>, *Sorokoumov V.N.*<sup>1</sup>

<sup>1</sup>Saint Petersburg State University, Saint Petersburg, Russia  
<sup>2</sup>Sechenov Institute of Evolutionary physiology and biochemistry  
 Russian Academy of Sciences, Saint Petersburg, Russia

Student  
[ashambel@gmail.com](mailto:ashambel@gmail.com)

Current research is dedicated to a number of new low-molecular-weight (LMW) regulators of the thyroid system that were created based on the structure of thieno[2,3-*d*]pyrimidine and that are endowed with the activity of inverse agonists and neutral antagonists of the thyroid stimulating hormone (TSH) receptor. By decreasing both basal and stimulated TSH and activating antibodies activity of the TSH receptor, these compounds can be effective for the treatment of hyperthyroidism (Graves' disease), thyroid cancer caused by activating mutations in the TSH receptor, as well as for the treatment of TSH-dependent tumors of non-thyroid localization [1].



**Figure 1.** Synthesis Scheme.

According to the Synthesis Scheme, ten new compounds were gained and characterized. The synthetic scheme described in the patent [2] was taken as a basis. TP-48, that is the key compound for the formation of the thieno[2,3-*d*]pyrimidine derivatives library, has an iodine substituent at the 4-position of the benzene ring. The high reactivity of the selected halogen in Pd-catalyzed cross-coupling reactions with the possibility of postmodification under the 1,3-azide-alkyne cyclo-addition [3] allows to introduce various substituents at the 4<sup>th</sup> position of the benzene ring at the final stages of synthesis and, thus, to provide a wide variability of the obtained TSH receptor LMW ligands.

Compounds TP-48 and TP-Y1 not only showed high affinity for the TSH receptor, but were also able to dose-dependently suppress basal and TSH-stimulated production of thyroid hormones *in vitro* and *in vivo*.

### References

- [1] Rapoport B., McLachlan S.M. *Thyroid*. **2007**, 17(10), 911–922
- [2] Hanssen R.G.J.M., Timmers C.M. *World Patent*, **2003**, WO2003020726
- [3] Mikhaylov et al. *Chem. Heterocycl. Compd.* **2020**, 56(7). p. 915–922

Acknowledgements. This work was supported by the Russian Science Foundation (project No 19-75-20122). The work was also performed by equipment of SPbU Research Park: RC MRR, RC CAMR.



SYNTHESIS OF NOVEL N, O – MACROCYCLIC LIGANDS CONTAINING  
 POSPHINE OXIDE GROUPS AS PENDANT – ARMS

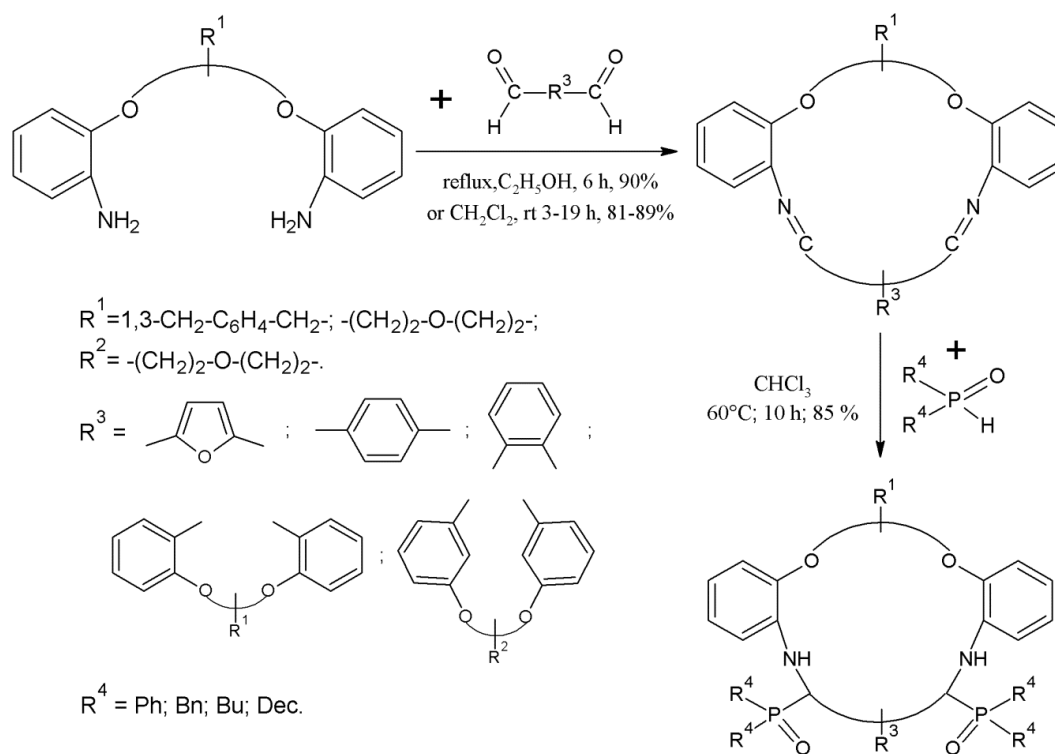
*Bogdanova A.N., Mukhina Yu.V., Pushkina K.A., Vakhrusheva E.D., Aleksandrova E.A., Trishin Yu.G.*

Saint Petersburg State University of Industrial Technologies and Design  
 Higher School of Technology and Energy, Saint Petersburg, Russia  
 Student

[juliamysh8@gmail.com](mailto:juliamysh8@gmail.com)

The design of macrocyclic receptors with specific structural features is one of the relevant objectives of supramolecular chemistry. Macrocycles satisfying these requirements usually contain central hydrophilic cavities surrounded by electronegative or electropositive binding atoms and external skeletons that cause hydrophobicity. Such compounds are used in pharmaceuticals, food chemistry, hydrometallurgy, agriculture, and materials science. Depending on the number, position and orientation of donor groups included in the macrocycle structure, as well as on the ring size, highly selective ligands can be obtained for certain metal ions [1]. However, macrocycles, on the skeleton of which phosphoryl groups are located, are poorly studied and are of considerable interest as specific ligands, which combine the complexing ability of phosphonates and macrocyclic compounds. Substances of this structure are capable of selective recognition of substrates, based on the principle of multipoint binding, and the manifestation of biological activity, which makes it possible to use them as antibacterial drugs, herbicides, fungicides, pesticides, antibiotics, antiviral, antithrombotic, antitumor, and anti-HIV agents [2].

This work is the development of our research [3] and expands the spectrum of new macrocyclic ligands and their  $\alpha$ -aminophosphoryl derivatives. Macrocyclic products of various structures were obtained by the condensation of dicarbonyl compounds with diamines followed by the addition of secondary phosphine oxides at the C=N bond (the Pudovik reaction).



**Figure 1.** Reaction condensation of dicarbonyl compounds with diamines followed by the addition of secondary phosphine oxides

#### References

- [1] Moreno-Corral R., Höpfl, H., Machi-Lara L., Lara K. *Eur. J. Org. Chem.* **2011**,11, 2148 – 2162  
 [2] Kocak S. B., Uckardes H. *Heteroatom Chemistry* **2012**, 23, 583 – 597  
 [3] Trishin Yu.G., Aleksandrova E.A., Lotsman K.A., Lyssenko K.A. *Chem. Heterocycl. Compd.* **2019**, 55, 875–881

# RING-OPENING OF DONOR-ACCEPTOR CYCLOPROPANES WITH *N*-NUCLEOPHILES IN THE SYNTHESIS OF HETEROCYCLES

Boichenko M.A.<sup>1</sup>, Ivanova O.A.<sup>1,2</sup>, Trushkov I.V.<sup>2</sup>

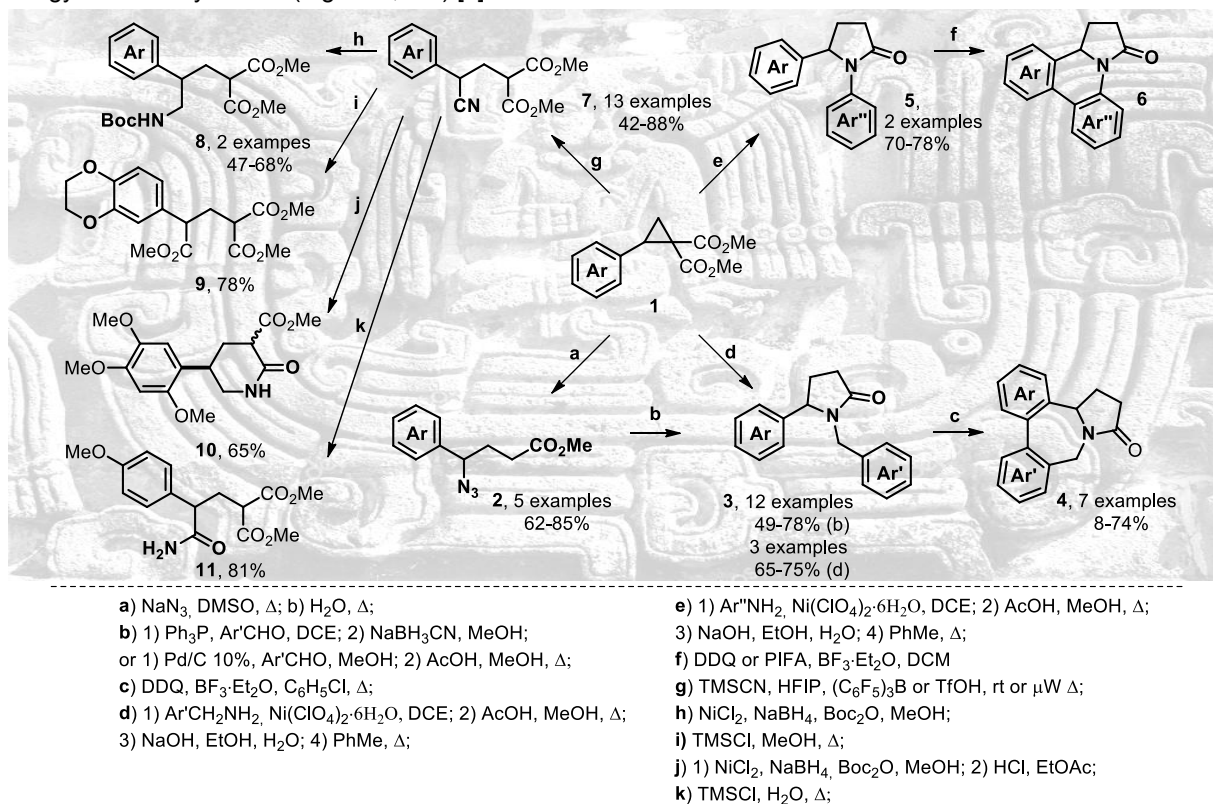
<sup>1</sup>Moscow State University, Moscow, Russia

<sup>2</sup>N.D. Zelinsky Institute of Organic Chemistry, Moscow, Russia

Postgraduate

[diopase.96@gmail.com](mailto:diopase.96@gmail.com)

Donor-acceptor cyclopropanes (DAC) are versatile substrates for the synthesis of various carbo- and heterocycles, including polycyclic ones, which are structural analogs of bioactive natural compounds and approved drugs [1]. Due to the polarization of the bond between carbon atoms, bearing donor and acceptor substituents, these cyclopropanes undergo efficiently (3+n)-cycloadditions, annulations and nucleophilic ring openings. Here, we present the results of our investigations of DAC reactions with a variety of nitrogen-containing nucleophiles, such as azide ion, benzyl amines, anilines, surrogates of cyanide ion, and diverse post-modifications of primary reaction products (Figure 1). Namely, 5-aryl-1-(arylmethyl)pyrrolidin-2-ones were obtained via either 3-step procedure including DAC opening with azide ion (Figure 1, a, b) or by Lewis acid-induced reaction of DAC with benzylamines (Figure 1, c). These substrates, containing two electron-rich aromatic groups, underwent the oxidative aryl-aryl coupling to afford dibenzo[*c,e*]pyrrolo[1,5-*a*]azepines related to allocolchicine, which is known as potent anticancer agent (Figure 1, d) [2]. We also synthesized 1,5-diarylpyrrolidinones using Lewis acid-catalyzed reaction of DAC with substituted anilines (Figure 1, e). It was demonstrated that the oxidative aryl-aryl bond formation in these substrates produced the corresponding dibenzindolizidinones (Figure 1, f). At last, we realized cyclopropanes **1** opening with trimethylsilylcyanide as surrogate of cyanide ion (Figure 1, g). It opens access to glutaric and  $\delta$ -aminovaleric acids, 3-arylpiperidines, various substituted  $\beta$ -phenylethylamines as well as other compounds that can be valuable intermediates in biology-oriented synthesis (Figure 1, h-k) [3].



**Figure 1.** Reactions of DA cyclopropanes with *N*-nucleophiles and post-modifications of the obtained products.

## References

- [1] Singh P., Varshnaya R.K., Dey R., Banerjee P. *Adv. Synth. Catal.* **2020**, 362, 1447–1484  
 [2] Boichenko M.A., Ivanova O.A., Andreev I.A., Chagarovskiy A.O., Levina I.I., Rybakov V.B., Skvortsov D.A., Trushkov I.V. *Org. Chem. Front.* **2018**, 5, 2829–2834  
 [3] Boichenko M.A., Andreev I.A., Chagarovskiy A.O., Levina I.I., Zhokhov S.S., Trushkov I.V., Ivanova O.A. *J. Org. Chem.*, **2020**, 85, 1146-1157

Acknowledgements. This work was supported by the Russian Science Foundation (project No 21-13-00395).

# SUPERELECTROPHILIC ACTIVATION 1-VINYL-PYRROLIDINE-2-ONE IN REACTION WITH ARENES

*Borisova M.A.*<sup>1</sup>, *Ryabukhin D.S.*<sup>1,2</sup>, *Vasilyev A.V.*<sup>1</sup>

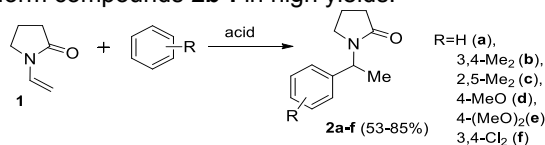
<sup>1</sup>Department of Chemistry, Saint Petersburg State Forest Technical University, Institutsky per., 5, Saint Petersburg, 194021, Russia, e-mail: marina96.00@mail.ru

<sup>2</sup>All-Russia Research Institute for Food Additives – Branch of V.M. Gorbatov Federal Research Center for Food Systems of RAS, Liteyniy pr., 55, Saint Petersburg, 191014, Russia

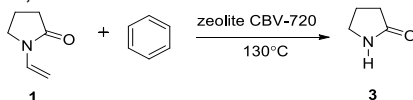
Derivatives of pyrrolines (tetrahydropyrroles) are of biological importance. Pyrrolidine is found in carrots, tobacco leaves, in alkaloids of the Solanaceae family. Pyrrolidine ring is part of many natural biologically active compounds such as nicotine, atropine, proline, hydroxyproline. Pyrrolidine structure used in pharmaceutical industry for the creation of certain drugs of a nootropic nature, the most of famous of which is pyrocetam. The development of methods for the synthesis of new compounds of the pyrrolidine series is an important task of organic synthesis.

The purpose of this work was to study the reactions of 1-vinyl-pyrrolidine-2-one with arenes under the action of Brønsted superacid (CF<sub>3</sub>SO<sub>3</sub>H), Brønsted acid H<sub>2</sub>SO<sub>4</sub> and strong Lewis acids AlCl<sub>3</sub>, AlBr<sub>3</sub>.

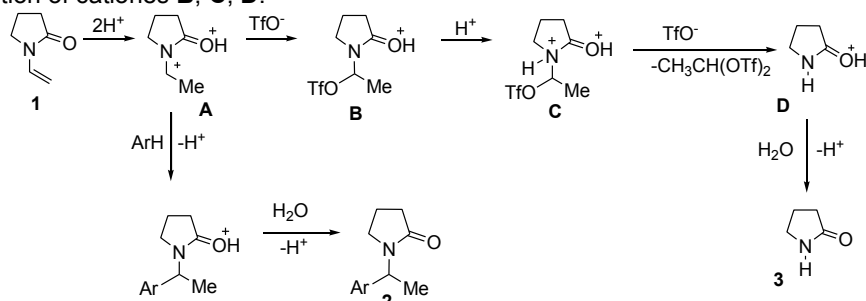
Pyrrolidine **1** reacts with arenes in CF<sub>3</sub>SO<sub>3</sub>H (TfOH) at room temperature in 1–2 hours, leading to substances **2a-f** in 53–85% yields. Thus, when interacting with benzene for 2 h, compound **2a** is has been obtained in a yield of 60%. A use of Lewis acid AlBr<sub>3</sub> in the reaction leads to the same compound for 80 min with in a yield 78%, with AlCl<sub>3</sub> for 1.5 h in yield of 85%. Substance **1** reacts with *o*-, *m*- и *p*-xylenes, anisole, veratrol and *o*-dichlorbenzene to form compounds **2b-f** in high yields.



In the reaction of compound **1** under the action of an acidic zeolite CBV-720 or in TfOH (without benzene), a devilination product, pyrrolidine-2-one **3**, has been formed.



The proposed reaction mechanism includes a protonation of pyrrolidinone **1** with the formation of dication **A**, which upon an interaction with arenes gives compounds **2**. There is an another way, compound **1** upon protonation in TfOH (or under the action of zeolite) is converted into a product of devilination **3** through the intermediate formation of cationes **B**, **C**, **D**.



Additionally, cation **D** was generated from substance **1** in TfOH directly in the NMR tube.

Thus, 1-vinylpyrrolidin-2-one **1** can be electrophilically activated by the action of Brønsted superacid TfOH or Lewis acids AlCl<sub>3</sub>/AlBr<sub>3</sub>. The cationic species generated under these conditions from compound **1** in reactions with arenes form 1-(1-arylethyl)pyrrolidin-2-ones **2**.

Acknowledgements. This work was supported by the Russian Foundation for Basic Research (RFBR grant № 20-03-00074).

# SYNTHESIS AND PROPERTIES OF CATIONIC MESO-ARYLPORPHYRINS FOR ANTIBACTERIAL PHOTODYNAMIC THERAPY

*Bortnevskaia Yu.S.*<sup>1</sup>, *Savelyeva I.O.*<sup>1</sup>, *Mironov A. F.*<sup>1</sup>, *Bragina N.A.*<sup>1</sup>, *Feofanov A.V.*<sup>2</sup>,  
*Ignatova A.A.*<sup>2</sup>, *Shmigol T.A.*<sup>3</sup>, *Zhdanova K.A.*<sup>1</sup>

<sup>1</sup>MIREA - Russian Technological University, Moscow, Russia

<sup>2</sup>Shemyakin-Ovchinnikov Institute of Bioorganic Chemistry, RAS, Moscow, Russia

<sup>3</sup>N. I. Pirogov Russian National Research Medical University, Moscow, Russia

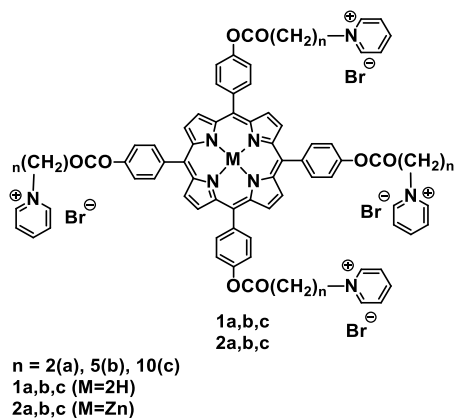
Student

[Bortnevskaia2000@yandex.ru](mailto:Bortnevskaia2000@yandex.ru)

Antimicrobial photodynamic therapy (PACT) is one of the most promising methods of treating diseases caused by various microorganisms. This method is an alternative to the standard therapeutic methods due to the increasing resistance of microorganisms to antibiotics [1].

PACT uses a photosensitizer (PS), which, upon irradiation with light of the appropriate wavelength generates cytotoxic reactive oxygen species (ROS). In turn, ROS causes oxidative stress in cellular targets. Synthetic porphyrin structures have proven themselves as photosensitizing agents in PACT [2,3]. However, the search for more effective PS continues. Cationic *meso*-arylporphyrins are promising compounds for PACT.

This work is devoted to the synthesis of symmetric porphyrins with terminal limit groups separated from the macrocycle by aliphatic spacers of two, five, and ten methylene units, as well as their zinc metal complexes. For the obtained PS, the photophysical properties and the aggregation behavior in water-organic media were studied.



**Figure 1.** Structure of the studied compounds.

Antibacterial activity of the obtained compounds against the suspension and biofilms of *S. aureus* and *E. coli* was studied in the absence of light exposure and when irradiated. In vitro experiments have shown that all the studied cationic porphyrins exhibit dark toxicity against *S. aureus*. Irradiation with white light increases the activity of the compounds in question in relation to Gram-positive bacteria. With an increase in the length of the substituents, a decrease in antibacterial activity is observed. In relation to *E. coli*, the efficiency of the obtained PS was slightly lower and 100% inhibition was not achieved in the studied concentration range. White light exposure does not significantly increase the antibacterial activity of cationic porphyrins compared to dark conditions.

As a result of biological tests, the effect of the obtained PS on the ability to inactivate the spread of cancer cells and on the healing of wound surfaces was also studied. After treating the Hep-2 cells with compounds **1a** and **2a**, the wound surface completely healed. While the treatment of PS **1b** and **2b** cells resulted in only partial wound healing. Consequently, compounds **1b** and **2b** have a stronger effect on cell migration inhibition compared to PS **1a** and **2a**. Thus, substances **1b** and **2b** reduce the proliferation of cancer cells and can be used in antitumor therapy.

## References

- [1] Masiera N., Bojarska A. *J. Photochem. Photobiol.* **2017**, *174*, 84–89
- [2] Branco T.M., Valério N.C. *Photodiagnosis. Photodyn. Ther.* **2018**, *21*, 285–293
- [3] Zhdanova K.A., Savelyeva I.O. *Dyes Pigm.* **2020**, *181*, 108561

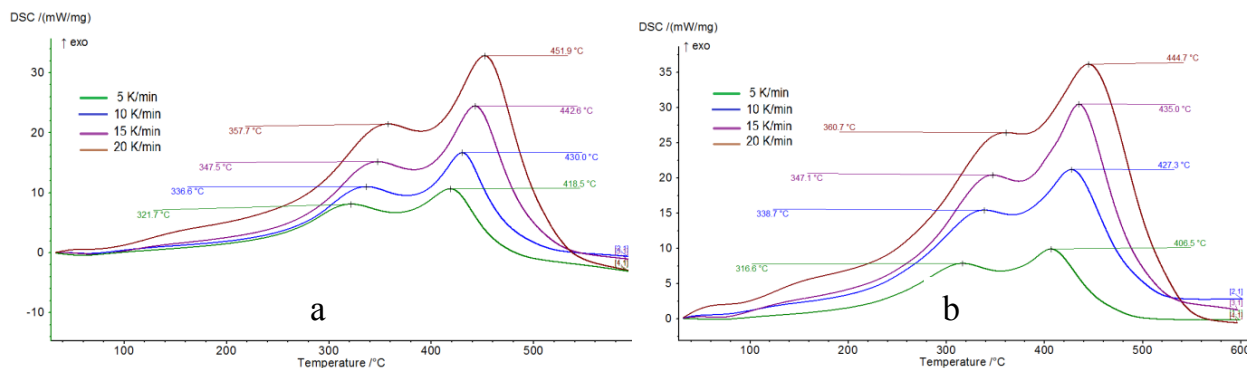
Acknowledgements. This work was supported by the Russian Science Foundation (projects No 20-73-00286, No 20-73-10239).

## COMPARISON BETWEEN CATALYTIC AND NON-CATALYTIC PYROLYSIS OF CAUSTOBIOLITHS

*Bulanova S.A.*<sup>1,2</sup>, *Tajik A.*<sup>3</sup>, *Vakhin A.V.*<sup>3</sup>, *Denisenko A.N.*<sup>2</sup>, *Glyavin M.Yu.*<sup>2</sup>,  
*Krapivnitckaia T.O.*<sup>2</sup>, *Peskov N. Yu.*<sup>1,2</sup>, *Zelentsov S.V.*<sup>1</sup>

<sup>1</sup>Lobachevsky State University, Nizhny Novgorod, Russia  
<sup>2</sup>Institute of Applied Physics RAS, Nizhny Novgorod, Russia  
<sup>3</sup>Kazan Federal University, Kazan, Russia  
PhD Student  
[bulanova@ipfran.ru](mailto:bulanova@ipfran.ru)

Using products of processing organic raw materials into biofuel is of great interest. To obtain it, mainly biological and thermal methods are used. In particular, processing is used by means of direct combustion of fuel, electric heating, heating with gas-oil burners, etc. However, the use of these techniques is not always effective and convenient to use in industry. Powerful electromagnetic radiation is capable of providing bulk heating of raw materials while minimizing the temperature gradient. This property increases the yield during processing of solid organic substances (caustobioliths) such as peat, kerogen, etc., and also reduces the number of additional manipulations and stages for this technology and satisfies the foundations of green chemistry [1]. Also, according to these environmental principles new processing technologies should be developed using catalysts. By decrease in the activation energy the efficiency of the process increases. Hence, the consumption of energy resources becomes lower. One of the main problems in the peat's development is the lack of a detailed description of the destruction process in the presence of catalysts, especially when it is exposed by electromagnetic radiation. However, the use of catalysts in peat processing can increase the conversion to oxygen-containing compounds, which play a positive role in biofuels. This work is devoted to the study of using iron-based catalysts in microwave pyrolysis of peat. The catalyst was synthesized as described in [2].



**Figure 1.** DSC curves for peat non-catalytic (a) and catalytic (b) oxidation.

Based on the results of the study, several conclusions can be drawn. First, there are two main areas of oxidation. Comparative graphs for the catalytic and non-catalytic oxidation of peat are shown in Fig. 1 and Fig. 2. Second, the catalyst adopted for this study increased the rate of the process by shifting the peak temperatures at which low-temperature and high-temperature oxidation reactions occur to lower regions. That says about the prospects of using this catalyst in peat processing.

It should be noted that the introduction of catalytic additives into peat samples, for example, coke-like catalysts characterized by a high level of absorption of microwave energy and its transformation into heat, increases the efficiency of their heating. This property not only improves the quality of the fuel, increases the number of pores of the solid carbonaceous residue, but also reduces the overall cost of microwave pyrolysis [3].

### References

- [1] Gómez-López P., Puente-Santiago A., Castro-Beltrán A., Nascimento L.A.S., Balu A.M., Luque R., Alvarado-Beltrán C.G., *Current Opinion in Green and Sustainable Chemistry* **2020**, 24, 48-55
- [2] Feoktistov D.A., Kayukova G.P., Vakhin A.V., Sitnov S.A., *Chem. Technol. Fuels Oils* **2018**, 53(6), 905-912
- [3] Vakhin A.V., Tajik A., Gafurov M.R., Morozov O.G., Nasybullin A.R., Ponomarev A.A., Krapivnitckaia T.O., Glyavin M.Yu., Khelkhal M.A., Karandashov S.A., Slavkina O.V., Shchekoldin K.A., *Processes* **2021**, 9(3), 420

Acknowledgements. This work was supported by IAP RAS State Task Project (No 0035-2019-0001).

# SYNTHESIS OF SUPRAMOLECULAR COMPLEXES OF CYCLODEXTRINS WITH BICYCLIC AND CAGE COMPOUNDS - NEW SERIES OF ENCAPSULATED SOLUBLE EPOXIDE HYDROLASE INHIBITORS WITH ENHANCED BIOAVAILABILITY

*Burmistrov V.V.*

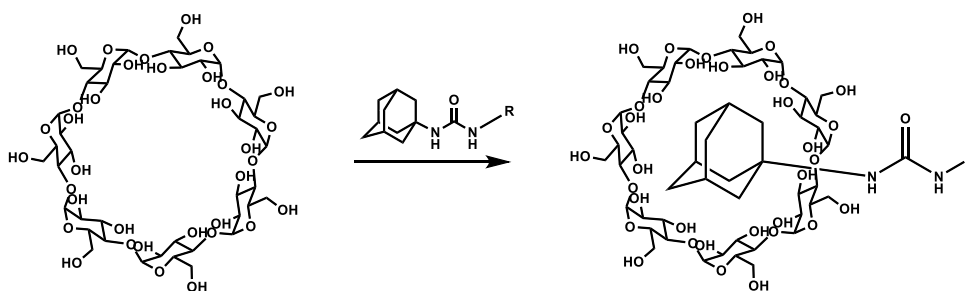
<sup>1</sup>Volgograd State Technical University, Volgograd, Russia  
Young scientist  
[crus\\_himself@mail.ru](mailto:crus_himself@mail.ru)

A new generation of bioavailable water-soluble inhibitors of soluble epoxide hydrolase, which are supramolecular complexes of disubstituted ureas with cyclodextrins, was synthesized, and their physicochemical properties, inhibitory activity and metabolic stability were studied.

The high lipophilicity of previously synthesized soluble epoxide hydrolase inhibitors ( $IC_{50} < 1$  nM) made them a target of metabolic enzymes and adversely affected water solubility, which made their use *in vivo* difficult. In this case, the encapsulation of such highly active inhibitors by the formation of supramolecular complexes with cyclodextrins, is an urgent task. Such encapsulation allows increasing the solubility of inhibitors containing lipophilic groups, which greatly simplifies the process of their delivery. In addition, while in the cavity of the cyclodextrin, the lipophilic group will not be available for the oxidation by cytochromes P450. Attempts to create complexes of cyclodextrin with soluble epoxide hydrolase inhibitors have not been undertaken before.

A series of symmetric diureas has been synthesized, promising when used as inhibitors of soluble epoxide hydrolase of two structural motifs, which previously demonstrated inhibitory activity in a separate group (1. Methylene bridge between the ureide group and the adamantyl fragment; 2. Two methyl substituents in the adamantyl fragment). An interesting effect of the dependence of the melting temperature of synthesized diureas on the length of the methylene bridge was found, at which the melting point of ureas with an odd number of carbon atoms in the methylene bridge between urea groups is lower than the melting temperature of neighboring ureas with an even number in the bridge. Earlier [1], we observed a similar phenomenon in a series of similar diureas obtained on the basis of unsubstituted 1-isocyanatoadamantane. However, in that case, the opposite effect was observed and the melting temperature of diureas with even bridges was lower.

For a number of 1,3-disubstituted ureas, complexes with  $\alpha$ - and  $\beta$ -cyclodextrin were obtained (Figure 1). It was found that the most suitable method for the preparation of complexes consists in active mixing of stoichiometric amounts of 1,3-disubstituted urea and cyclodextrin in a mixture of ethanol: water (1: 3) at a temperature of 80 ° C. After evaporating by half, the solution was left to crystallize at a temperature of ~ 4 ° C. The precipitated crystals were analyzed by NMR spectroscopy. Complex formation was determined in the NOESY experiment and by X-Ray crystallography.



**Figure 1.** Formation of complexes with  $\beta$ -cyclodextrin

Thus, the methods for the preparation of 12 adamantyl-containing and bicyclic isocyanates, and over 200 1,3-disubstituted ureas and diureas based on them were developed and optimized. Also obtained 10 complexes of 1,3-disubstituted ureas with cyclodextrins. For the synthesis of adamantyl-containing isocyanates, the reaction of 1,3-dehydroadamantane and 1,3-dehydro-5,7-dimethyladamantane with ethyl ester of phenylacetic acid followed by hydrolysis of the ether and treatment with diphenylphosphoryl azide was used. The inhibitory activity of the synthesized ureas against human soluble epoxide hydrolase was studied and the enantiomeric specificity of this enzyme was found (the S isomer is 13.6 times more active than the R isomer). A procedure was developed for the preparation of complexes of 1,3-disubstituted ureas with cyclodextrins, and 10 complexes were obtained.

## References

[1] Burmistrov V., Morisseau C., Harris T.R., Butov G., Hammock B.D. *Bioorg. Chem.*, **2018**, 76, 510–527.

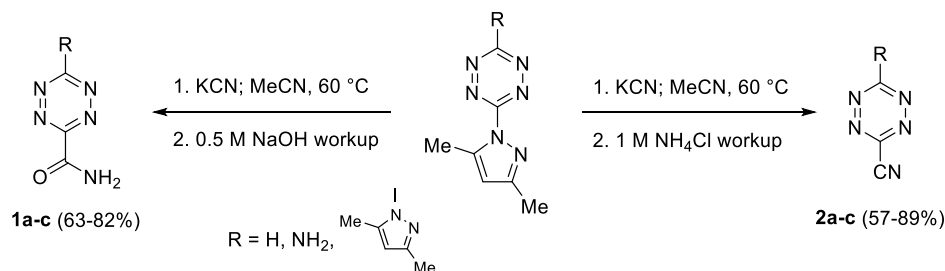
Acknowledgements. This work was supported by the Russian Science Foundation (project No 19-73-10002).

NOVEL METHODS FOR THE SYNTHESIS AND TRANSFORMATION  
OF FUNCTIONALLY SUBSTITUTED S-TETRAZINES

*Bystrov D.M.*<sup>1</sup>, *Fershtat L.L.*<sup>1</sup>

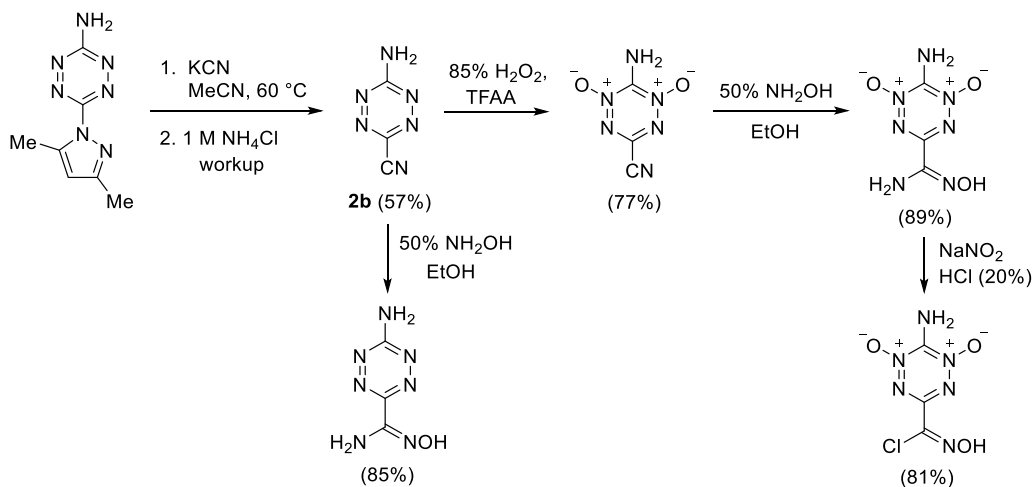
<sup>1</sup>N.D. Zelinsky Institute of Organic Chemistry RAS, 47 Leninsky prosp., 119991 Moscow, Russian Federation  
PhD Student  
[bystrov@ioc.ac.ru](mailto:bystrov@ioc.ac.ru)

About 30 years ago s-tetrazine derivatives were shown to have an excellent thermostability along with outstanding explosive performance and high enthalpies of formation [1]. Such properties are of special importance in the design and synthesis of new energetic materials. However, a very limited number of approaches toward direct introduction of explosophoric moieties to a s-tetrazine ring were developed.



**Figure 1.** Nucleophilic substitution of a 3,5-dimethylpyrazolyl group in s-tetrazines by CN-anion.

Herein, we present a new method for the nucleophilic substitution of 3,5-dimethylpyrazolyl group in s-tetrazines by cyanide anion. Depending on the workup procedure, amides (**1a-c**) or nitriles (**2a-c**) can be obtained with moderate to good yields (Fig. 1).



**Figure 2.** Synthesis of new energetic aminotetrazine derivatives.

Using the developed procedure we successfully synthesized 3-amino-6-cyano-1,2,4,5-tetrazine **2b** with moderate yield. This compound was then used as a useful precursor to a number of new, previously inaccessible energetic aminotetrazine derivatives (Fig. 2).

### References

[1] D. E. Chavez, M. A. Hiskey, *J. Energ. Mater.*, **1999**, 17, 357

Acknowledgements. This work was supported by the Russian Foundation for Basic Research and Moscow city Government according to the research project № 21-33-70056.

NEW PECTIN COMPLEXES WITH TETRACYCLINE: SYNTHESIS,  
PROPERTIES AND ANTIMICROBIAL ACTIVITY

*Chekunkov E.V., Minzanova S.T., Mironova L.G., Voloshina A.D., Milyukov V.A.*

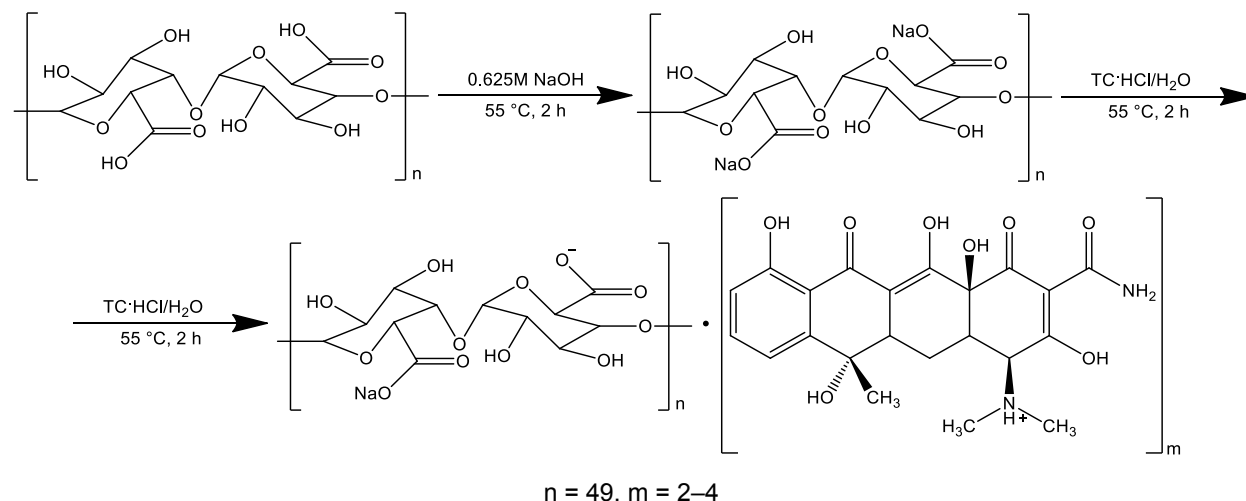
Arbuzov Institute of Organic and Physical Chemistry, FRC Kazan Scientific Center, Russian Academy of Science, Kazan, Russia  
Post-graduate student  
[evchekunkov@gmail.com](mailto:evchekunkov@gmail.com)

**Introduction:** Currently, the search for highly effective and non-toxic antimicrobial drugs remains an urgent task [1]. It is known that the complexation of drugs with polysaccharides reduces the negative effect of the gastrointestinal tract and improve the organoleptic properties of the obtained substances [2].

**Methods:** A series of experiments was carried out, which made it possible to study the regularities of pectin complexation depending on the tetracycline concentration, the pH value of the initial solution, and also to determine the characteristics of the obtained products. As a result of the interaction of a 2% aqueous solution of sodium polygalacturonate (PGNa) with solutions of tetracycline hydrochloride in aqueous ethanol (by varying the concentration of the drug), complexes 1–5 were synthesized (Fig. 1). The mass ratio of PGNa and tetracycline hydrochloride in complexes 1–5 varied within 8.0: 1.0 – 3.1: 1.0. A preliminary aqueous solution of PGNa was obtained by treating a 2% solution of citrus pectin solution with a 0.625 M NaOH solution. Subsequently, the obtained products (1–5) were precipitated with EtOH, centrifuged, and additionally washed with EtOH to purify the complexes from physically sorbed tetracycline, dried, and reground.

**Results:** Complexation of sodium pectate and tetracycline hydrochloride was established by methods of IR and UV spectroscopy, powder X-ray diffraction, dynamic light scattering. The stoichiometry of the obtained complexes was found, antimicrobial (bacteriostatic and bactericidal) activity was assessed in relation to test strains: *Staphylococcus aureus*, *Bacillus cereus*, *Escherichia coli*. Analysis of the obtained experimental data showed that binding of PGNa to tetracycline does not lead to a decrease in its antimicrobial action. Moreover, MIC and MBC of complexes 4 and 5 are comparable with the activity of the pure tetracycline against all test microorganisms.

**Conclusions.** On the basis of this study, the possibility of complexation of pectin polysaccharides with the antimicrobial drug "Tetracycline" was shown to obtain non-toxic water-soluble (bioavailable) complexes with antimicrobial action.



**Figure 1.** Synthesis of the PGNa-tetracycline complexes.

**References**

- [1] Moghaddam R.H., Dadfarnia S., Shabani A.M.H. *et al. Mater. Sci. Eng. C.* **2019**, 102, 391–404  
[2] Chekunkov Y.V., Minzanova S.T., Khabibullina A.V. *et al. Russ. Chem. Bull. (Int. Ed.)* **2020**, 69, 572–580

**Acknowledgements.** This work was supported by the Russian Foundation for Basic Research (project number 20-33-90222).



# SELF-ESSEMBLED BINARY AND TERNARY COMPLEXES BETWEEN STYRYL DYES, DNA AND CUCURBIT[7]URIL

*Chernikova P.A.*<sup>1,2</sup>, *Chernikova E.Y.*<sup>1</sup>, *Fedorov Y.V.*<sup>1</sup>, *Fedorova O.A.*<sup>1</sup>.

<sup>1</sup>Laboratory of Photoactive Supramolecular Systems, A.N. Nesmeyanov Institute of Organoelement Compounds of Russian Academy of Sciences, Russia

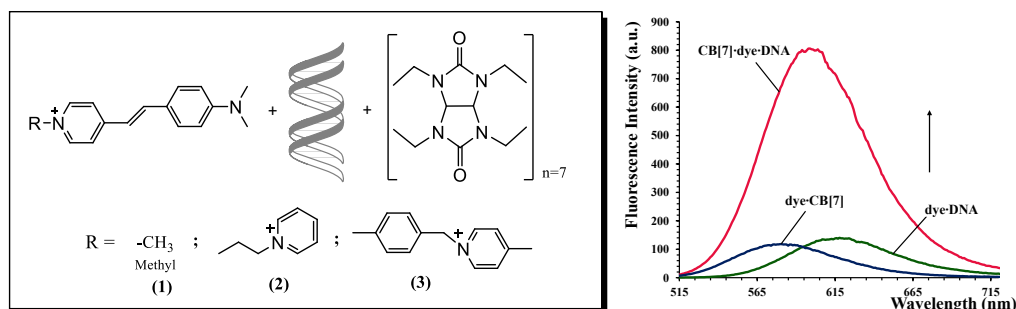
<sup>2</sup>Moscow Institute of Physics and Technology, Russia

PhD Student

chernikova.pa@phystech.edu

The guest-host systems based on non-fluorescence organic molecules containing a specific chromophore groups in order to bind with calf thymus DNA and cucurbit[7]uril (CB[7]) as a molecular container makes it possible to obtain the effective supramolecular assemblies for biological purposes [1]. The interaction with DNA (especially, through the groove binding), as well as encapsulation in the CB[7] cavity lead to a significant increase in the fluorescence response of organic dyes. Increasing of emission intensity upon the direct interaction of a ligand with DNA allows to obtain a non-invasive optical imaging method for real-time detection and monitoring of various biological processes [2-3].

This study devoted to the influence of CB[7] on the ligand–DNA association and optical response of N–dimethylamino–substituted styryl dyes in phosphate buffer solution. Competition and cooperative interactions appearing in the three-component system between dyes, DNA and CB[7] have been carefully investigated.



**Figure 1.** The structures of styrylpyridinium derivatives (1, 2, 3), DNA, CB[7] and fluorescence response of binary and ternary systems.

It was shown that at certain concentrations of the components, a ternary system is formed in a noncovalent way, in which DNA molecules interact with the chromophore fragment of dye 3, while CB[7] host molecules occupies the linker tail. It is assumed that CB[7] will reduce the cytotoxicity of the supramolecular system and contribute to its penetration into cells with high efficiency. Binding modes for binary and ternary complexes of dyes with DNA and CB[7] have been established using UV/vis absorption, fluorescence, CD, NMR spectroscopy and competitive titration with Hoechst33258 and ethidium bromide.

## References

- [1] Chernikova E.Y., Ruleva A.Y. *Org Biomol Chem.* **2020**, *18*, 755–766
- [2] Ustimova M.A., Chernikova P.A. *Mendeleev Commun.* **2020**, *30*, 217-219
- [3] Ivanov D.A., Petrov N.K. *J. Phys. Chem. A* **2011**, *117*, 4505–4510

Acknowledgements. This work was supported by Russian Foundation for Basic Research (project No 19-03-00625).

# STUDY ON ELECTRONIC CHARACTERISTICS OF SOME 3-ALKENYL-OXINDOLES BY ABSORPTION SPECTROSCOPY

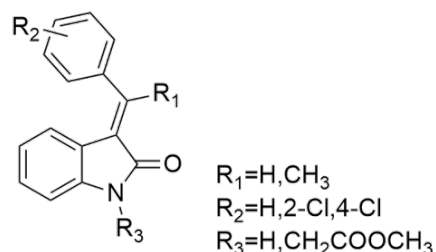
*Chernomyz M.S.<sup>1</sup>, Lvova M.Yu.<sup>1</sup>, Novikova D.S.<sup>1</sup>*

<sup>1</sup>Saint-Petersburg State Institute of Technology, Saint Petersburg, Russia  
Student

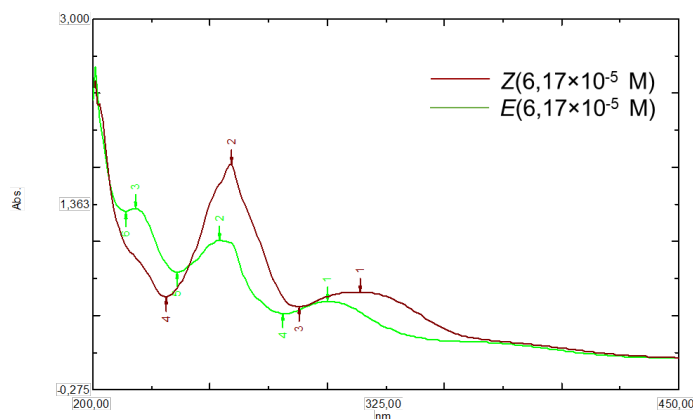
e-mail: [chernomiz.1999@gmail.com](mailto:chernomiz.1999@gmail.com)

To date, 3-alkenyl-oxindole derivatives are of great interest due to their wide application in medicinal chemistry and drug design [1]. This is mostly determined by their synthetic availability. However, there are some issues arising from their possible isomerism.

The problem of 3-alkenyl-oxindole isomerization has not been completely understood yet. Since we deal with 3-benzylideneoxindole AMPK activators [2], we were interested in the effect of substitutions on the ability to isomerize. For this purpose, we obtained a series of intermediate products and studied their spectral characteristics (Figure 1).



**Figure 1.** Series of 3-benzylideneoxindole derivatives.



**Figure 2.** UV-Vis spectrum of (Z)-3-(1-(4-chlorophenyl)ethylidene)indolin-2-one and (E)-3-(1-(4-chlorophenyl)ethylidene)indolin-2-one in MeOH.

We analyzed electronic absorption spectra of two single isomers (*E*- and *Z*-) for each of the studied derivative (Figure 2). The spectra of the isolated isomers were compared. The data obtained were used to determine absorption maxima, calculate the molar absorption coefficients, establish electronic transitions characteristic for the studied molecules, and also assess the electronic effect of the substituents.

## References

- [1] Alessia Millemaggi, Richard J. K. Taylor. 3-Alkenyl-oxindoles: Natural Products, Pharmaceuticals, and Recent Synthetic Advances in Tandem/Telescoped Approaches. *Eur. J. Org. Chem.* 2010, 2010 (24), 4527-4547.
- [2] Novikova D.S., Grigoreva T.A., Zolotarev A.A., Garabadzhiu A.V., Tribulovich V.G. Advanced palladium free approach to the synthesis of substituted alkene oxindoles via aluminum-promoted Knoevenagel reaction. *RSC Adv.*, 2018, 8, 34543-34551.

This work was supported by the Russian Science Foundation (project no. 19-73-10150).

RESEARCH ON THE APPLIED PROPERTIES OF DERIVATIVES  
OF SPATIALLY HINDERED PHENOLS

*Chubynin<sup>1</sup> N.A., Urazaev<sup>1</sup> E.I., Pistsova<sup>1</sup> A.L., Ibragimova<sup>1</sup> D.A., Alexanyan<sup>2</sup> A.R., Alexanyan<sup>2</sup> K.G.,  
Shamsutdinova<sup>1</sup> L.P.*

<sup>1</sup>Kazan National Research Technological University, Kazan, Russia.  
<sup>2</sup>National University of Oil and Gas «Gubkin University», Moscow, Russia  
Student  
n.chubynin@mail.ru

The research of synthesis and properties of different derivatives of spatially hindered phenols are carried out at the department of organic chemistry of KNRTU. Previous studies have shown that the introduction of hetero-atoms into the structure of hindered phenols significantly affects their properties. We have synthesized several objects for the study of applied properties at the Department of chemical engineering of KNRTU and Gubkin Russian State University of Oil and Gas (NRU). We chose Agidol-0, Agidol-1 and Agidol-3 as starting compounds and reference standards. Synthesized objects of research: (Table 1).

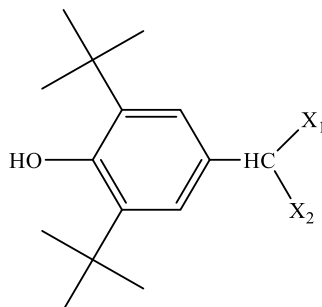


Table 1: Synthesized hindered phenols

Connection number	X <sub>1</sub>	X <sub>2</sub>
1	P(O)Et <sub>2</sub>	CH <sub>2</sub> C(O)CH <sub>3</sub>
2	P(O)Et <sub>2</sub>	NC(O)C <sub>6</sub> H <sub>4</sub> C(O)
3	P(O)(OMe) <sub>2</sub>	SCH(P(O)Ph <sub>2</sub> )(2,6-ди- <i>t</i> -BuC <sub>6</sub> H <sub>4</sub> OH)
4	P(O)Ph <sub>2</sub>	P(O)(OEt) <sub>2</sub>
5	P(O)Ph <sub>2</sub>	S-( <i>o</i> -NH <sub>2</sub> )C <sub>6</sub> H <sub>5</sub>
6	P(O)(OEt) <sub>2</sub>	OMe

The first study was the study of rheological properties of oil, namely the effect of hindered phenols on the viscosity of oil emulsions. According to the results of the study, oil viscosity decreases with increasing shear rate. Viscosity of oil emulsions is characterized by the appearance of extremum at shear rates from 110 to 170 rpm. Hindered phenols proved ineffective as viscosity modifiers, but it was suggested that they could be used as inhibitors of asphalt-resin-paraffin deposition [1].

The purpose of the following study was to evaluate the inhibiting effect of samples 1 and 2.

As a result of the experiment, the most effective inhibitor 4 was determined, which in the future can be used in the oil field to prevent the formation of asphalt-resinous deposits. It was found that sample 1 showed the best results, and it was suggested that it can be used in the oilfield to prevent the formation of asphalt-resinous deposits. This compound is currently being compared to the industrial antioxidants Agidol-0, 1 and 3.

At the moment the research of compounds 1, 3, 4, 5, 6 has been completed.

Based on the results of the study, we concluded that the compounds studied have a different contribution to the resistance to oil oxidation. According to the values obtained we can judge about the antioxidant activity of compounds, but they lose to the industrial antioxidant Agidol-3.

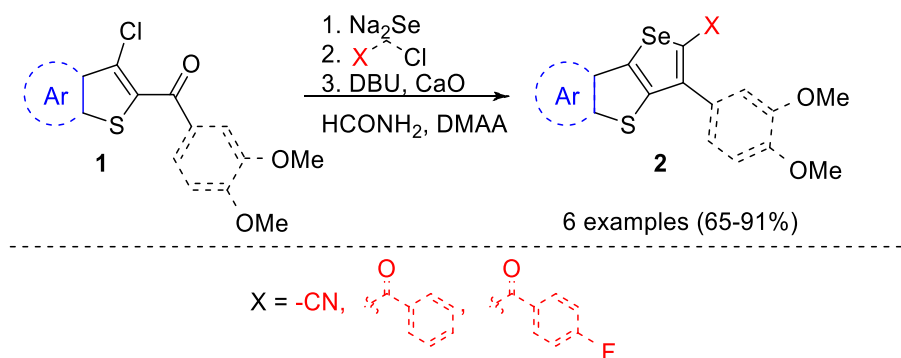
#### References

[1] The study of the solubility of paraffin deposits in the narrow oil fractions. D. A. Ibragimova, L. P. Shamsutdinova, Z. F. Sharafieva [et al.], *17th international multidisciplinary scientific geoconference SGEM 2017*.

<sup>1</sup>Postovsky Institute of Organic Synthesis, Ekaterinburg, Russia[nadezhda.s.demina@gmail.com](mailto:nadezhda.s.demina@gmail.com)

At present, much attention is paid to chalcogen-containing small molecules and polymers, especially selenophene-based ones, due to the unprecedented characteristics of materials based on them, which are applicable in the field of organic electronics. For instance, several studies devoted to the creation of non-fullerene organic solar cells based on selenophene-containing materials with an efficiency of up to 17% have recently been reported.[1-2] This demand for compounds based on the selenophene ring determines the urgency of developing new methods for introducing this structural element into the molecule.

Thus, we proposed the novel efficient synthesis of the selenopheno[3,2-*b*]thiophene fragment by treating substrates **1** with sodium selenide in a mixture of *N,N*-dimethylacetamide and formamide, followed by the addition of an alkylating agent with a methylene bridge and a base to obtain the desired selenopheno[3,2-*b*]thiophene-based products **2** in 65-91% yields (Figure 1).



**Figure 1.** Synthesis of selenopheno[3,2-*b*]thiophene-based compounds **2**

### References

- [1] Cao J., Qu S., Yu J., Zhang Z., Geng R., Yang L., Wang H., Du F., Tang W. *Mater. Chem. Front.*, **2020**, *4*, 924–932.  
 [2] Qi F., Jiang K., Lin F., Wu Z., Zhang H., Gao W., Li Y., Cai Z., Woo H.Y., Zhu Z., Jen A.K.Y. *ACS Energy Lett.*, **2021**, *6*, 9–15.

Acknowledgements. This work was supported by the Russian Science Foundation (project No 19-13-00234).

*Dzyubenko V.V.<sup>1,2</sup>, Ryabukhin D.S.<sup>1</sup>*

<sup>1</sup>All-Russia Research Institute for Food Additives — Branch of V.M. Gorbатов Federal Research Center for Food Systems of RAS, Saint Petersburg, Russia

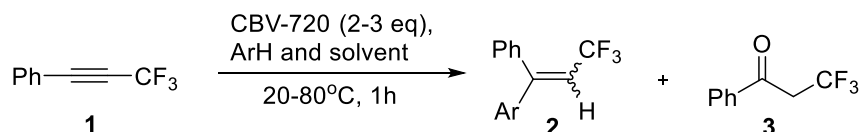
<sup>2</sup>Saint Petersburg State Forestry University, Saint Petersburg, Russia

Student.

torrid18@yandex.ru

Fluorine-containing organic compounds are widely used in all areas of technology with its extreme operating conditions, and are also very important for both theoretical and applied chemistry, physics, biology, medicine and other fields of science. The development of new selective methods for the synthesis and modification of fluorinated compounds is an urgent problem in organic chemistry.

The main purpose of this work was studying the reactions of phenylacetylene **1**, containing a trifluoromethyl electron acceptor group CF<sub>3</sub>, with arenes under the action of acidic zeolites HUSY.



**Figure 1.** Reaction of phenyl acetylene **1** with arenes under the action of zeolite HUSY.

By analogy with the reactions carried out with Bronsted superacids [1,2], we expected that HUSY zeolite CBV-720 would be able to activate alkynes **1** in reaction with arenes. Indeed, phenylacetylene **1** reacted with benzene under the action of HUSY zeolite to form diphenylethylene **2** and ketone **3** (Table 1). The experimental procedure was simple and included calcining the zeolite at 550 °C for 4 hours to activate it, followed by its stirring with alkyne **1** (1 mmol) in an excess of arene (1-2 ml) in a high-pressure glass tube. The reaction did not occur at room temperature (Table 1, entry 1). An increase temperature up to 60°C, made it possible to obtain the final product **2** in mixture with ketone **3** (Table 1, entry 2). Formation of the latter product was possible as a result of Kucherov's reaction. Anhydrous benzene did not solve the problem (Table 1, entries 3,6). In absence of benzene in the reaction media, only the hydration product **3** was formed (Table 1, entry 4). Use of p-Xylene instead of benzene in the same reaction makes it possible to completely suppress the Kucherov reaction, leading to a mixture of the corresponding *E/Z*-alkenes **2** (Table 1, entry 7).

**Table 1.** Reactions of acetylene **1** with benzene under the action of zeolite HUSY CBV-720.

№	Conditions				Yield of products, (%)		Total yields, (%)
	T, °C	eq. HUSY	ArH	Solvent	<b>2</b>	<b>3</b>	
1	20	2	2 mL PhH	—	0	0	0 <sup>a</sup>
2	60	2	2 mL PhH tech. grade	—	29	5	34
3	60	2	2 mL PhH unh.	—	71	21	92
4	60	2	—	2 mL CH <sub>2</sub> Cl <sub>2</sub>	0	75	75
5	60	2	1 ml PhH unh.	1 mL C <sub>6</sub> H <sub>12</sub> unh.	11	9	20
6	80	3	2 mL PhH unh.	—	25	13	38
7	80	3	2 mL p-xylene	—	51	0	51

Note. <sup>a</sup>Regenerated 83% of phenylacetylene **1**.

In this work, we have proposed a simple and effective method for the synthesis of trifluoromethylated diphenylethylene **2** and ketone **3** by reacting the corresponding acetylene with benzene in the presence of acidic zeolites. Because of its simplicity and clarity, this approach can serve as a useful alternative to existing methods.

#### References

- [1] Alkhafaji H.M.H., Ryabukhin D.S., Muzalevskiy V.M., Vasilyev A.V., Fukin G.K., Shastin A.V., Nenajdenko V.G. // *European Journal of Organic Chemistry* **2013**, 1132–1143.  
 [2] Alkhafaji H.M.H., Ryabukhin D.S., Muzalevskiy V.M., Osetrova L.V., Vasilyev A.V., Nenajdenko V.G. *Russ. Journal of Org. Chem.* 2013, 327–341.

Acknowledgements. This work was supported by the Ministry of Science and Education of the Russian Federation (Grant Agreement 0585-2019-0044).

# SYNTHESIS AND PROPERTIES OF MULTIFLUOROPHORIC RED FLUORESCENT DYES BASED ON BODIPY

*Efremova A.V.*<sup>1</sup>, *Kononevich Yu.N.*<sup>1</sup>, *Pakhomov A.A.*<sup>2</sup>, *Ionov D.S.*<sup>3</sup>, *Muzafarov A.M.*<sup>1</sup>

<sup>1</sup>A.N. Nesmeyanov Institute of Organoelement Compounds,  
Russian Academy of Sciences, Moscow, Russia

<sup>2</sup>M.M. Shemyakin–Yu. A. Ovchinnikov Institute of Bioorganic Chemistry,  
Russian Academy of Sciences, Moscow, Russia

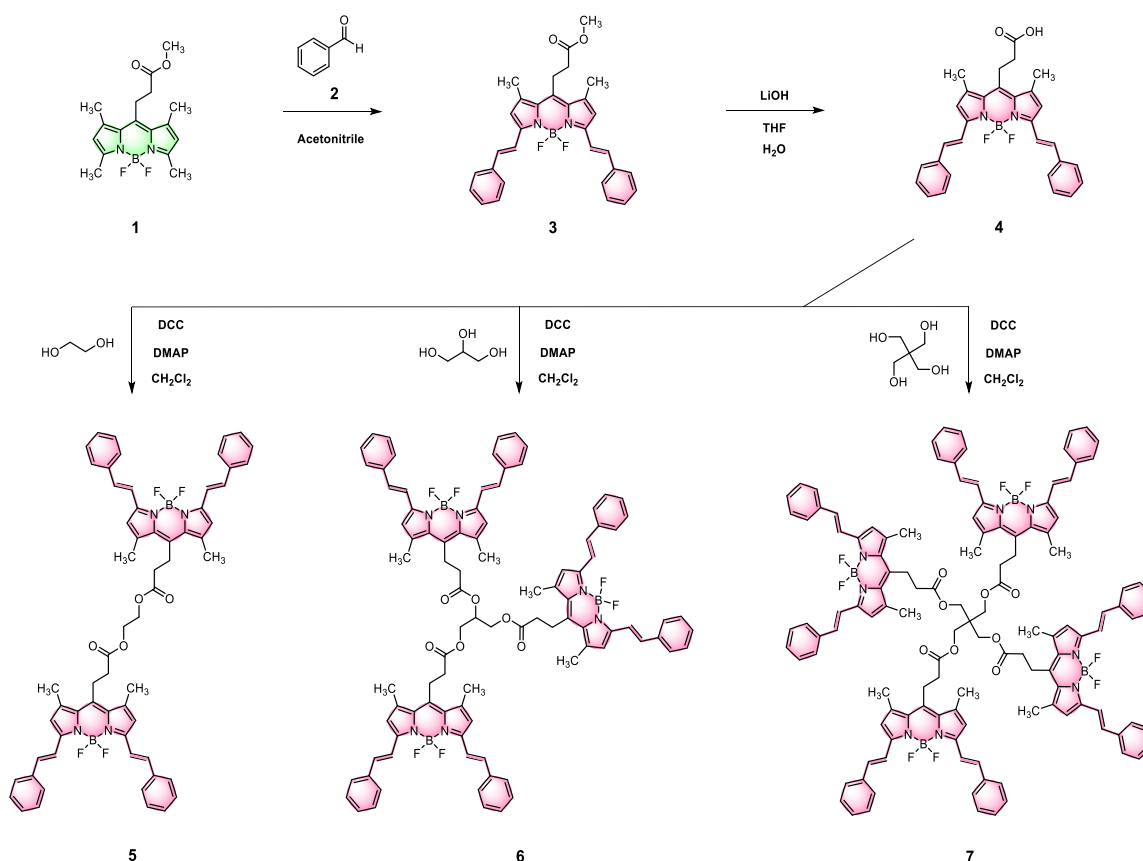
<sup>3</sup>Photochemistry Center, “Crystallography and Photonics” Federal Research Center,  
Russian Academy of Sciences, Moscow, Russia

Student

[annie.efremova@gmail.com](mailto:annie.efremova@gmail.com)

**Boron dipyrromethene (BODIPY)** -based fluorescent dyes are widely used in biomolecular imaging due to high coefficient of extinction, a high quantum fluorescence yield, and excellent photostability [1]. Nevertheless, in some cases the brightness of fluorophores is not enough for detailed bioimaging of the processes that are occurs inside live cell. The brightness itself determined by two parameters: the quantum yield and the coefficient of extinction. One of the methods to increase brightness based on combining several BODIPY fluorophores together in a single molecule, the coefficient of extinction in that case increased in proportion to the number of fluorophores [2].

In this work, we have synthesized a number of red multifluorophoric systems based on BODIPY for the purposes of bioimaging. Physicochemical and photophysical properties of obtained compounds have been studied. Two-photon absorption spectral properties have been also investigated.



**Figure 1.** Synthesis of red multifluorophoric BODIPY derivatives.

## References

- [1] Kaur P., Singh K. J. Mater. Chem. C. **2019**, 7, 11361-11405.
- [2] Pakhomov A. A. et al. Tetrahedron Lett. **2016**, 57, 979-982.

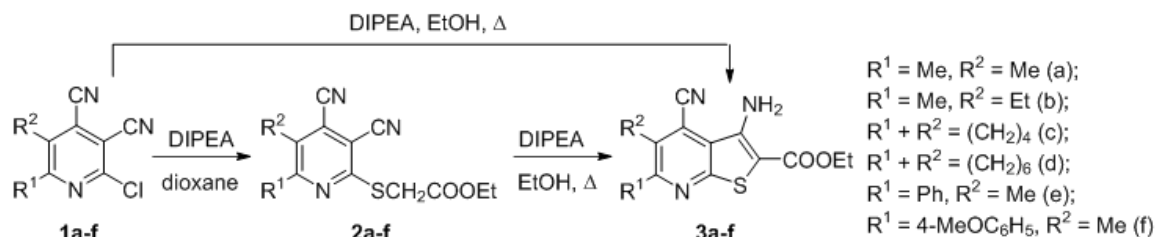
Acknowledgements. This work was supported by the Russian Science Foundation (project No 19-73-20194)

I.N. Ulianov Chuvash State University, Cheboksary, Russia  
 Postgraduate student  
[colt\\_m16@bk.ru](mailto:colt_m16@bk.ru)

Over the past decade, cancer continues to be a major global problem. A few heterocyclic compounds are currently on the market as antineoplastic agents. Condensed pyridines are widely used in neurology, in the treatment of neurodegenerative disorders such as Parkinson's disease, anxiety disorders, and depression [1].

We have obtained a number of 5,6-disubstituted ethyl-3-amino-4-cyanothieno[2,3-*b*]pyridine-2-carboxylates and studied their optical properties. The screening of the catalyst of the process and reaction conditions made it possible to develop a method for the preparation of intermediate pyridylthioacetates **2** and target thieno[2,3-*b*]pyridines **3** in good yields.

It was found that the reaction of 2-chloropyridine-3,4-dicarbonitriles **1** with ethyl thioglycollate in the presence of DIPEA in 1,4-dioxane at room temperature gives ethyl 2-((3,4-dicyanopyridin-2-yl)sulfanyl) acetates **2** with 81-96% yields. Carrying out the process under reflux in ethyl alcohol leads to the formation of ethyl 3-amino-4-cyanothieno[2,3-*b*]pyridine-2-carboxylates in 84-92% yields.



**Figure 1.** Reaction.

For all synthesized compounds **2** and **3**, the spectral-fluorescent properties were thoroughly studied and their relationship with the chemical structure was found. The study of the optical properties showed that the structure of compounds **2** and **3** significantly affects the electronic spectra. The long-wavelength absorption band of aryl-substituted compounds **2e,f** in a benzene solution (372-374 nm) shifts bathochromically as compared to alkyl derivatives **2a-d** (357-364 nm) and enhances extinction. Compounds **2a-d** are weakly fluorescent with maxima around 407-408 nm, while for phenyl- and 4-methoxyphenyl-substituted molecules, the radiation is stronger, and the maxima are shifted to longer wavelengths of 421 and 432 nm, respectively. Benzene solutions of thieno[2,3-*b*]pyridine derivative **3** are yellow due to the absorption band in the visible region at 406-420 nm, the extinction coefficient of the band increases for aryl-substituted compounds **3e, f**. The fluorescence of compounds **3** is more intense than the corresponding monocyclic derivatives **2** and is in the region of 535-549 nm. The relative quantum yield of fluorescence is the highest for 4-methoxyphenyl derivative **3f**. Solid state emission studies showed intense fluorescence in the blue-green region for compounds **2** and in the yellow region of the spectrum for thieno[2,3-*b*]pyridines **3**.

#### References

[1] Bhoomandla S., Gunda Sh. K., Kotoori S., Kanuparth Ph. R. *J. Heterocyclic Chem.* **2019**, *56*, 1986–1998.

Acknowledgements. This work was funded in the framework of State contract with the Ministry for Education and Science (project no. 0849-2020-0003).

# SELECTIVE FUNCTIONALIZATION OF VINYL AZIDES WITH *N*-OXYL RADICALS

*Fedorova U.V.*<sup>1</sup>, *Segida O.O.*<sup>2</sup>, *Paveliev S.A.*<sup>2</sup>, *Terent'ev A.O.*<sup>1,2</sup>

<sup>1</sup>D. Mendeleev University of Chemical Technology of Russia, Moscow, Russia

<sup>2</sup>N.D. Zelinsky Institute of Organic Chemistry of the Russian Academy of Sciences, Moscow, Russia

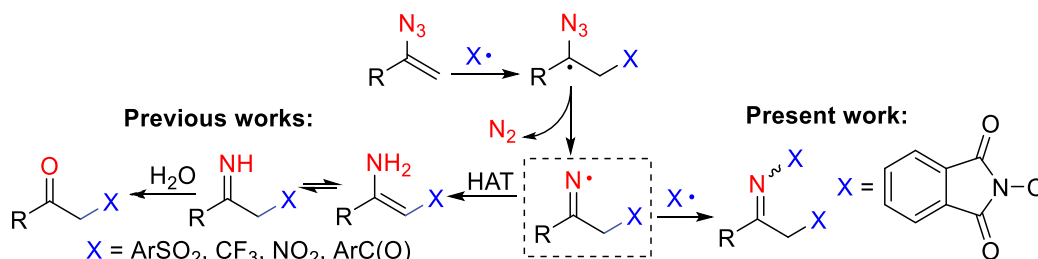
Student

[uliana.fedorova.2000@mail.ru](mailto:uliana.fedorova.2000@mail.ru)

In the last decade, the selective functionalization of compounds containing multiple carbon-carbon bonds in their structure has become an important area of modern organic chemistry. In the reactions of radical difunctionalization of alkenes with the usage of *N*-hydroxy compounds and the corresponding *N*-oxyl radicals, bifunctional products with C-O, C-C, C-N, and C-I bonds were obtained.

Vinyl azides used in this work have a rich spectrum of reactivity. They can act as nucleophiles, electrophiles, 1,3-dipolarophiles, and radical acceptors. Reaction of ArSO<sub>2</sub>•, NO<sub>2</sub>•, CF<sub>3</sub>•, ArC(O)• and various C-centered radicals with vinyl azides are known (Fig. 1) [1-4]. Usually, such processes are accompanied by the addition of a radical to the terminal carbon atom of the C=C bond of vinyl azides with the release of molecular nitrogen and the formation of an iminyl radical, which makes them convenient precursors of many classes of organic compounds. Depending on the reaction conditions, the formation of ketones, imines, and unsubstituted enamines can occur.

In this work, the selective addition of *N*-oxyl radicals to vinyl azides was discovered and carried out to form *O*-substituted oximes with an unusual N-O-N fragment. The sequential formation of C-O and N-O bonds is achieved through the generation and addition of imide-*N*-oxyl radicals with their subsequent recombination with iminyl radicals (Fig.1).



**Figure 1.** Transformations of vinyl azides with the formation of iminyl radicals

## References

- [1] Mulina O.M., Zhironkina N.V., Paveliev S.A., Demchuk D.V. *Org. Lett.* **2020**, *22*, 1818-1824
- [2] Ning Y., Zhao X.-F., Wu Y.-B., Bi X. *Org. Lett.* **2017**, *19*, 6240-6243
- [3] Kong X., Liu Y., Lin L., Chen Q., Xu B. *Green Chem.* **2019**, *21*, 3796-3801
- [4] Wang Q., Huang J., Zhou L. *Adv. Synth. Catal.* **2015**, *357*, 2479-2484

This work was supported by the Russian Science Foundation (project No 21-43-04417).



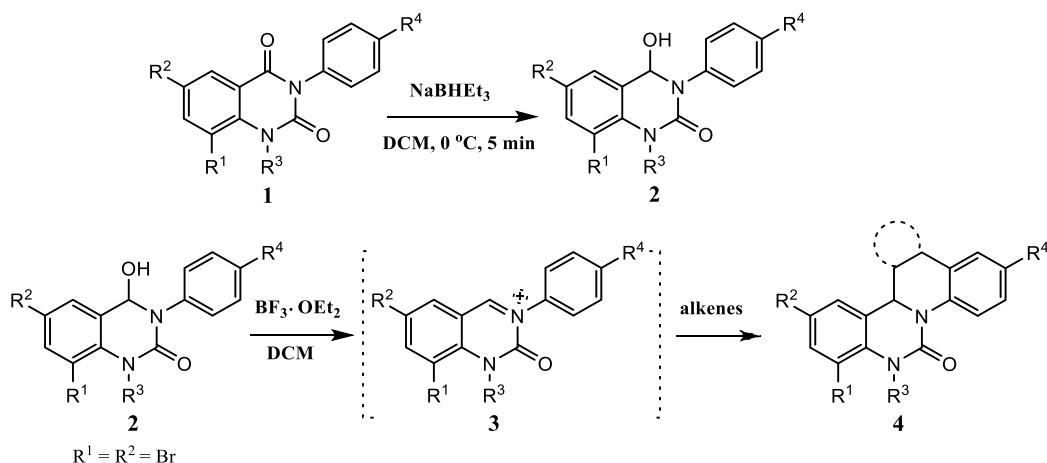
THE FORMAL [4+2]-CYCLOADDITION OF *N*-ACYLIMINIUM CATIONS TO ALKENES AS A CONVENIENT APPROACH TO THE SYNTHESIS OF QUINOLINO[1,2-*c*]QUINAZOLIN-6-ONE DERIVATIVES

*Filatov A.S., Stepakov A.V.*

Saint Petersburg State University, Saint Petersburg, Russia  
PhD student  
[st013663@student.spbu.ru](mailto:st013663@student.spbu.ru)

Nowadays, *N*-acyliminium cations are extensively used for the synthesis of bioactive complex nitrogen-containing heterocycles, especially in the preparation of alkaloid natural products. As a continuation of our efforts in the construction of nitrogen heterocycles *via N*-acyliminium electrophiles-involved reactions [1-2], we have developed a facile method for the synthesis of quinolino[1,2-*c*]quinazolin-6-one derivatives *via* formal [4+2]-cycloaddition of *N*-acyliminium cations to various alkenes.

In this study, we synthesized a range of unsubstituted, 6-substituted and 6,8-disubstituted 4-hydroxy-3-aryl-3,4-dihydroquinazolin-2(1*H*)-ones **2** by reduction of corresponding 3-arylquinazolin-2,4(1*H*,3*H*)-diones **1** with sodium triethylborohydride. All of obtained 4-hydroxy-3-aryl-3,4-dihydroquinazolin-2(1*H*)-ones **2** were readily dehydroxylated on treatment with boron trifluoride etherate to generate highly reactive *N*-acyliminium electrophiles **3**.



**Figure 1.** The two-step synthetic route to quinolino[1,2-*c*]quinazolin-6-one derivatives

When using unsubstituted and 6-substituted 4-hydroxy-3-aryl-3,4-dihydroquinazolin-2(1*H*)-ones **2**, we failed to trap the *N*-acyliminium ions **3** with alkenes probably due to its homopolymerization reaction *via* Friedel-Crafts alkylation. While *N*-acyliminium cations derived from 6,8-disubstituted 4-hydroxy-3-aryl-3,4-dihydroquinazolin-2(1*H*)-ones **2** did not undergo the polymerization reaction. These electrophiles **3** were captured with different alkenes to produce quinolino[1,2-*c*]quinazolin-6-one **4** derivatives in acceptable yields with high regio- and stereoselectivity. The structures and relative configurations of the resultant cycloadducts **4** were corroborated by NMR spectroscopy and X-ray analysis.

#### References

- [1] Stepakov A. V., Filatov A. S. et al *Tetrahedron* **2016**, 72, 5064–5073  
[2] Stepakov A. V., Filatov A. S. et al *Tetrahedron* **2017**, 73, 3949-3958

Acknowledgements. This work was supported by the Russian Foundation for Basic Research (Project No 20-33-90325).

SYNTHESIS OF ANHYDRIDES OF 1,1-DIOXIDE 4-(CARBOXYMETHYL)-2-ARYLSOETHIAZOLIDINE-5-CARBOXYLIC ACIDS AND STUDY OF THEIR ACTIVITY IN THE CASTAGNOLI-CUSHMAN REACTION

*Firsov A.A., Bakulina O.Yu.*

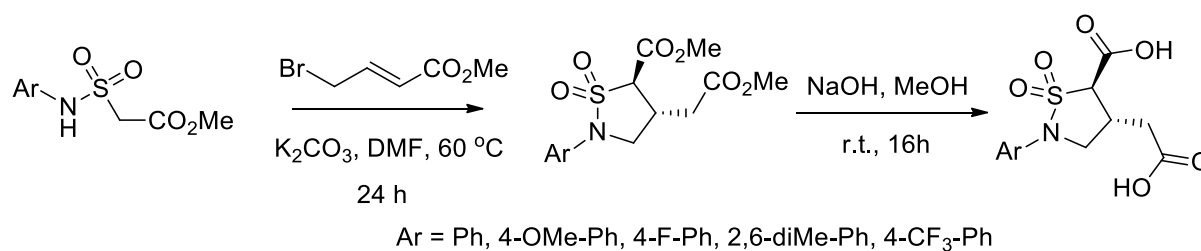
Saint Petersburg State University, Saint Petersburg, Russia

Student

[st044545@student.spbu.ru](mailto:st044545@student.spbu.ru)

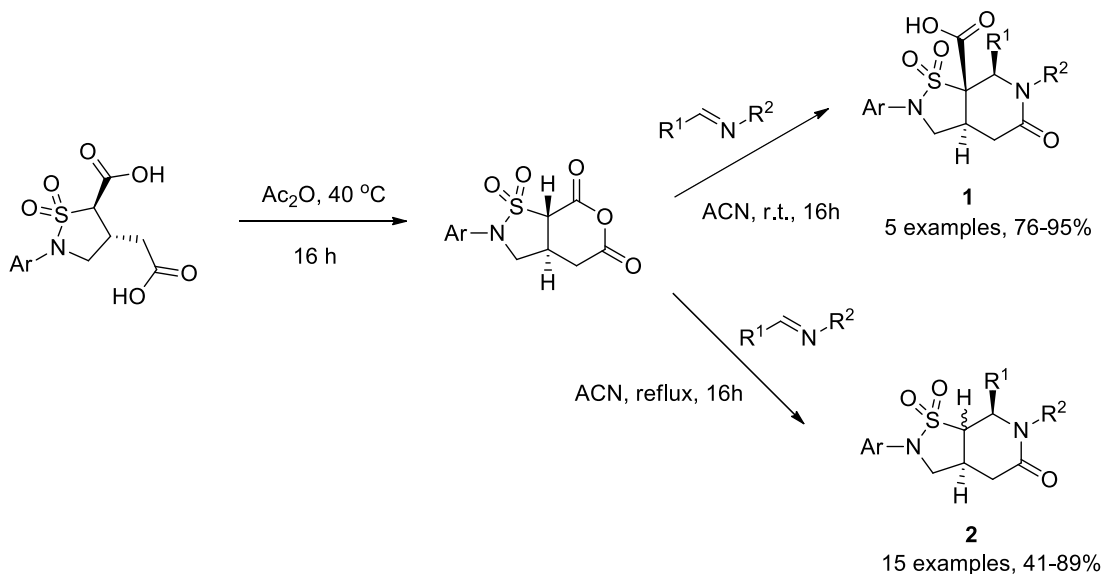
In 1969, the Castagnoli-Cushman reaction (CCR) was discovered - the interaction of cyclic anhydrides of carboxylic acids with Schiff bases. The products of this reaction are various lactam acids, which shows a wide spectrum of biological activity and are quite difficult to obtain. At this moment, there is a bit limited range of anhydrides introduced into CCR, therefore, discovering new classes of such substrates is a very promising task.

The aim of this work was to study the activity of novel 1,1-dioxide 4-(carboxymethyl)-2-arylisothiazolidine-5-carboxylic acid anhydrides in Castagnoli-Cushman reaction. The acids themselves were obtained using a tandem reaction of nucleophilic substitution/Michael addition from methyl ester of 4-bromocrotonic acid and methyl ester of 2-(*N*-arylsulfamoyl)-ethanic acid (Figure 1).



**Figure 1.**

A total of five different acids were obtained, and they all were used in this work. Anhydrides of the synthesized acids were obtained using acetic anhydride. After obtain, they were immediately introduced into the CCR (Figure 2). The substrates showed high activity, since they reacted at room temperature, which is very rare in the Castagnoli-Cushman reaction. In the course of our study, several lactam acids **1** were obtained, however, the main emphasis was placed on compounds **2**, obtained as diastereomeric mixtures by reflux in acetonitrile. Lactams **2** are products of decarboxylation of thermally unstable acids **1**. The structure of both products **1** and **2** was confirmed by X-ray crystallography.



**Figure 2.**

Acknowledgements. This work was supported by the grant of the President of the Russian Federation MK-1073.2020.3.

# THE REACTIVITY OF ETHYLENE CARBONATE DERIVATIVES TOWARD TO IMIDAZOLES

*Gabov I.S.*<sup>1,2</sup>, *Pestov A.V.*<sup>1,2</sup>

<sup>1</sup>Ural Federal University, 19 Mira Str., Ekaterinburg 620002, Russia

<sup>2</sup>Postovsky Institute of Organic Synthesis, Ural Branch of the Russian Academy of Sciences, 22 Sofia Kovalevskaya Str., Ekaterinburg 620137, Russia

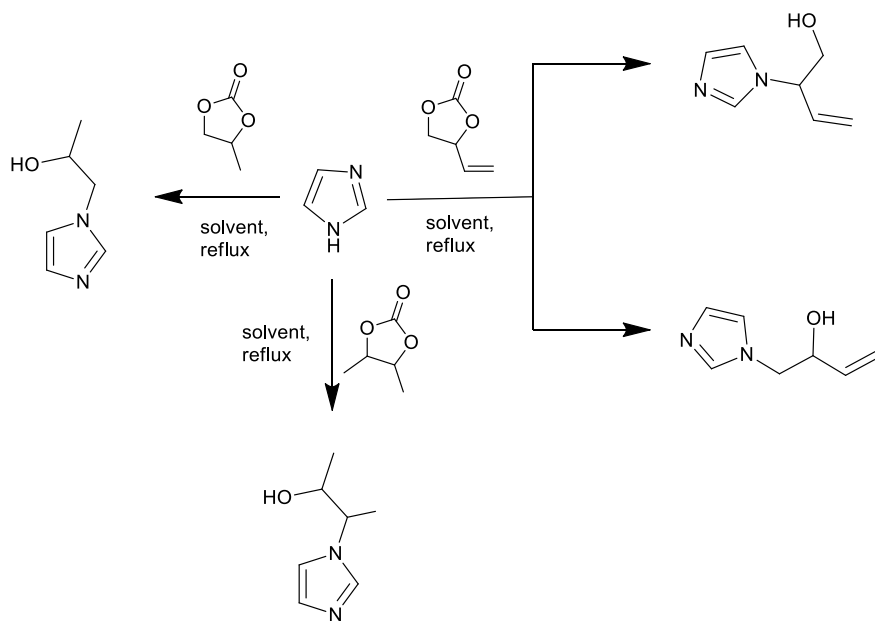
Student

[ivan.s.gabov@gmail.com](mailto:ivan.s.gabov@gmail.com)

Cyclic organic carbonates have recently been widely used in industry and human life, for example as organic solvents for lithium-ion accumulators, raw materials for the synthesis of polycarbonates, and are gaining popularity as convenient reagents in organic synthesis, due to their low toxicity and relative availability compared to other alkylating (alkyl halides) and carboxylating (phosgene) reagents [1]. Vinylethylene carbonate (VEC), propylene carbonate and 4,5-dimethyldioxolan-2-on are interesting reagents, since it contains four electrophilic carbon atoms, the interaction of nucleophiles with which can lead to a variety of products.

In this paper an attempt is made to compare alkylating ability of VEC, propylene carbonate and 4,5-dimethyldioxolan-2-on in relation to 1H-imidazole, 2-methylimidazole and benzimidazole.

The interaction of cyclic carbonates with imidazoles was carried out by reflux of the reaction mixture in the solvents. Aromatic hydrocarbons and glymes was used as solvents.



**Figure 1.** Reaction of imidazole with cyclic carbonates.

Products were isolated by distillation in vacuo. During the experiments, it was found that VEC reacts with imidazoles with formation of two regioisomers (Figure 1). Reactivity of imidazoles in the reaction with cyclic carbonates grows in series benzimidazole < 2-methylimidazole < 1H-imidazole. The composition and structure of the obtained compounds were characterized using the elemental analysis, FT-IR spectroscopy, and <sup>1</sup>H NMR spectroscopy.

In summary, we have presented the reaction of imidazole alkylation with cyclic carbonates as an environmentally safe synthesis method of imidazolyl alcohols.

## References

[1] Gabov I.S., Khamidullina L.A., Puzyrev I.S., Ezhikova M.A., Kodess M.I., Pestov A.V. *Russian Journal of Organic Chemistry*. **2020**, *56*, 1852-1861

COPPER-CATALYZED REACTION OF OXADIAZOLONES WITH DIARYLIODONIUM SALTS

*Geyl K.K.*<sup>1</sup>, *Semenov A.V.*<sup>2</sup>, *Soldatova N.S.*<sup>1,3</sup>, *Baykov S.V.*<sup>1</sup>, *Postnikov P.S.*<sup>3</sup>

<sup>1</sup>Saint Petersburg State University, Saint Petersburg, Russia

<sup>2</sup>MIREA – Russian Technological University, Moscow, Russia

<sup>3</sup>Tomsk Polytechnic University, Tomsk, Russia

Student

[kirillgeyl@outlook.com](mailto:kirillgeyl@outlook.com)

Heterocyclic compounds are a pivotal class of organic substances widely spread in natural and artificial products. Oxadiazolones are one of the promising heterocyclic compounds. For example, 1,2,4-oxadiazol-5(4*H*)-ones based drug Azilsartan medoxomil is registered for the therapy of hypertension [1]. Some 1,3,4-oxadiazol-2(3*H*)-ones derivatives were studied for treatment of type 2 diabetes[2]. However, despite their broad applicability, the synthetic approaches to *N*-arylated oxadiazolones remains limited. The only direct arylation of 1,2,4-oxadiazol-5(4*H*)-ones was demonstrated by Wang et al. in 2018 [3] using arynes as an arylation agent, which resulted in low regioselectivity.

In this work we used diaryliodonium salts as a source of electrophilic aryl intermediates in the arylation of 1,2,4-oxadiazol-5(4*H*)-ones and 1,3,4-oxadiazol-2(3*H*)-ones. Thus, we developed a mild and effective method for the arylation of oxadiazolones using inexpensive CuI as a catalyst. The developed approach displays the high applicability for the functionalization of 1,2,4-oxadiazol-5(4*H*)-ones bearing various substituents. Furthermore, a series of *N*-arylated oxadiazolones was synthesized with moderate to good yields.

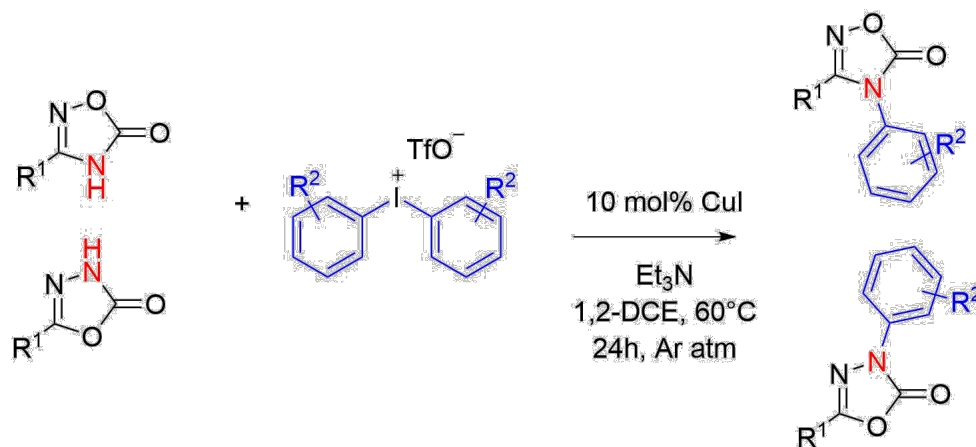


Figure 1. Reaction.

References

- [1] Baker, W.L., White, W.B. *Ann., Pharmacother.* **2011**, *45*, 1506–1515  
 [2] Moser, P. C.; Bergis, O. E.; Jegham, S.; Lochead, A.; Duconseille, E.; Terranova, J.-P.; Caille, D.; Berque-Bestel, I.; Lezoualc'h, F.; Fischmeister, R.; Dumuis, A.; Bockaert, J.; George, P.; Soubrié, P.; Scatton, B., *J. Pharmacol. Exp. Ther.* **2002**, *302*, 731–741.  
 [3] Zhou, L., Li, H., Zhang, W., Wang, L., *Chem. Commun.* **2018**, *54*, 4822-4825

Acknowledgements. This work was supported by the Russian Science Foundation (project No 19-73-00007) and Ministry of Science and Higher Education of Russian Federation in frame of the “Mega-grant” project (application No 2020-220-08-8827). The authors are grateful to the Center for X-ray Diffraction Studies, Magnetic Resonance Research Center, and Center for Chemical Analysis and Materials Research (all belonging to Saint Petersburg State University) for the physicochemical studies.

SYNTHESIS OF AZOPYRIMIDINES BY THE REACTIONS OF ETHOXYMETHYLIDENE  
DICARBONYL COMPOUNDS WITH AMINOAZOLES

*Gharibyan V.K.*<sup>1</sup>, *Danagulyan G.G.*<sup>1,2</sup>

<sup>1</sup>Russian–Armenian (Slavonic) University, Yerevan, Armenia

<sup>2</sup>Technological Center of Organic and Pharmaceutical Chemistry, National Academy of Sciences of the  
Republic of Armenia, Yerevan, Armenia

vache.gharibyan@mail.ru

Ph.D. Student

A general method for the synthesis of azopyrimidines containing a bridging nitrogen atom has been developed by the reactions of  $\alpha$ -amino azoles with ethoxymethylidene dicarbonyl compounds. It was shown that in all cases of the three functional groups of the carbonyl reagent, the ethoxymethylidene fragment of the molecule participates in the heterocyclization process. The regioselectivity of condensation was determined by NMR-spectroscopy (NOESY).

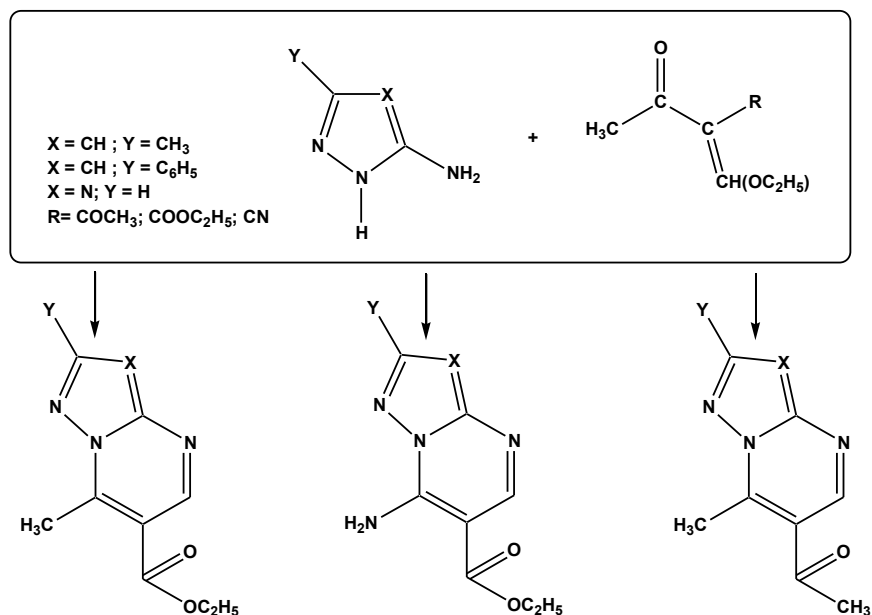


Figure 1.

Acknowledgements. This work was carried out with the financial support of the State Committee on Science of the Republic of Armenia and Russian Foundation for Basic Research RFBR (project 20RF-138 /20-53-05010 Am\_a/).

TRIPEPTIDE AND BIS-INDOLBENZOQUINONE DERIVATIVES FROM VIETNAMESE STRAIN  
OF MARINE-DERIVED FUNGUS ASPERGILLUS TERREUS

*Girich E.V.*<sup>1</sup>, *Dyshlovoy S.A.*<sup>2</sup>, *Yurchenko E.A.*<sup>1</sup>, *Yurchenko A.N.*<sup>1</sup>

<sup>1</sup>G.B. Elyakov Pacific Institute of Bioorganic Chemistry FEB RAS, Vladivostok, Russia

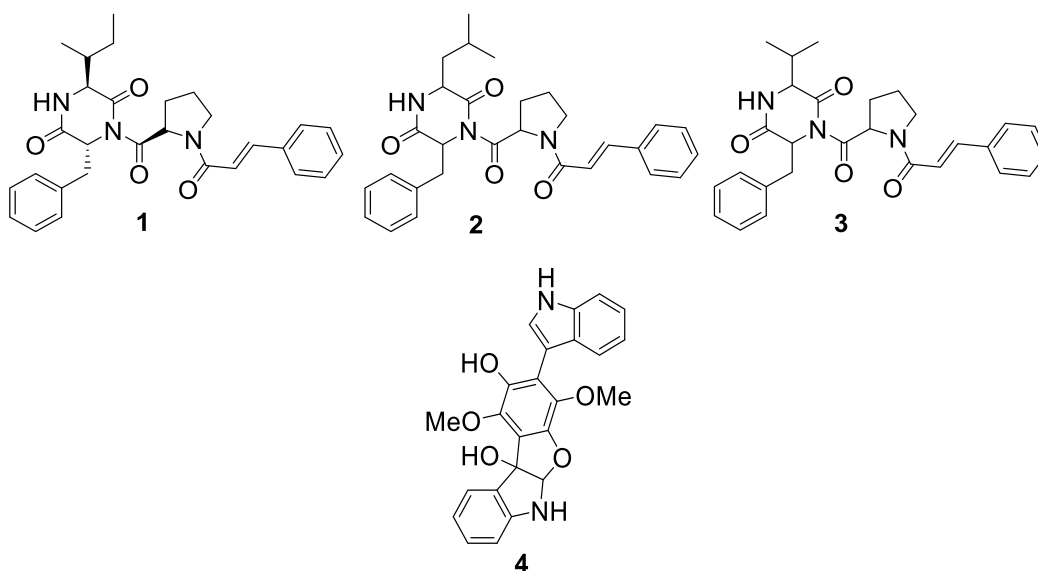
<sup>2</sup> Department of Oncology, Hematology and Bone Marrow Transplantation with Section Pneumology, Hubertus  
Wald-Tumorzentrum, University Medical Center Hamburg-Eppendorf, Hamburg, Germany

PhD-student

[ev.ivanets@ya.ru](mailto:ev.ivanets@ya.ru)

Marine-derived fungi inhabit difficult environmental conditions and produce compounds required for adaptation. Warm tropical marine waters have a particularly high density of bacterial population, which is an additional factor of competitive influence on marine fungi [1-2]. The coast of Vietnam is an insufficiently studied area of the South China Sea, because most researches are focused on the coast of China and Taiwan Strait. Therefore, investigation of Vietnamese coast fungi remains the relevant task.

The fungus *Aspergillus terreus* was isolated from leaf of unidentified mangrove tree (Khanh Hoa province, Vietnam). The thorough chromatographic separation of EtOAc extract using silica gel, sephadex LH-20 and following normal- and reverse-phase HPLC purification yielded 14 individual compounds. The structures of isolated compounds were established by 1D and 2D NMR spectroscopy and high-resolution mass spectrometry as three new tripeptide-derivatives asterripeptides A-C (**1-3**), known bis-indolbenzofuran-derivative asterriquinone F (**4**), and a number of known bis-indolbenzoquinone-derivatives asterriquinones A3, B4, C1, C2 and D, polyketide-derivatives 1,2,5-trihydroxy-7-methyl-9,10-anthroquinone, 4-hydroxy-3-(3-methyl-2-enyl)benzaldehyde and questine, as well as sesquiterpenoid quadrone and ergosterine-derivative 6 $\beta$ -hydroxyergosta-4,7,22-trien-3-on. The absolute configuration of all stereocenters of **1** was confirmed by Marfey's method with addition of L-FDAA derivatives [3].



**Figure 1.** Structures of compounds 1-4

We have investigated the effect of isolated compounds on the viability of human drug-resistant prostate cancer cell lines (22Rv1, PC-3, LNCaP), as well as neuroprotective properties in Parkinson's disease models induced by various neurotoxins.

#### References

- [1] Carroll A.R., et al. *Nat. Prod. Rep.*, **2020**, *37*, 175-223.
- [2] Carroll A.R., et al. *Nat. Prod. Rep.*, **2019**, *36*, 122-173.
- [3] Fujii K., et al. *Tetrahedron Lett.*, **1998**, *39*, 2579-2582.

This work was supported by the Russian Science Foundation (project No 19-74-10014).

THE FORMATION OF HYBRID RECEPTORS AND DENDRIMER-LIKE STRUCTURES  
BASED ON *RCTT* CALIX[4]RESORCINARENE

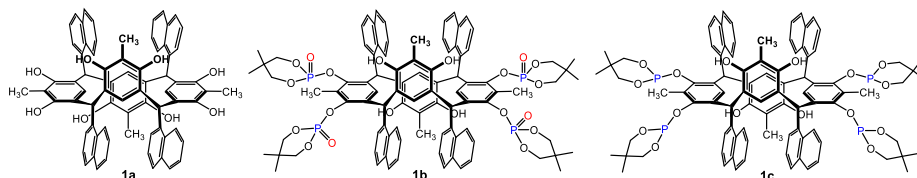
*Glushko V.V., Serkova O.S., Kudryavtseva M.P., Maslennikova V.I.*

Moscow Pedagogical State University, Moscow, Russia

Young scientist

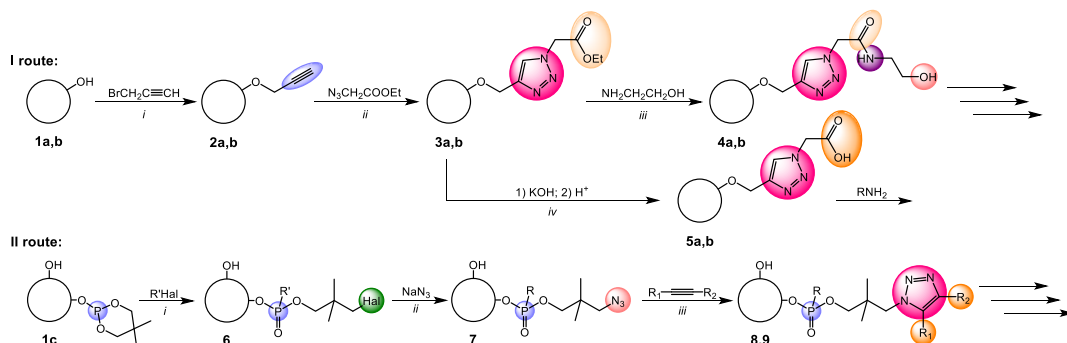
[vv.glushko@mpgu.su](mailto:vv.glushko@mpgu.su), [v07.glushko@gmail.com](mailto:v07.glushko@gmail.com)

Effective methods for synthesis of new hybrid systems with resorcinarene core and several heterofunctional branches that differ in composition and orientation in space were developed. *rctt* *Ortho*-methyl-tetra-*C*-naphthyl-calix[4]resorcinarenes **1a-c** existing in the rigid *chair* conformation and differing in number, location and reactivity of hydroxyl groups were used as the base platform (Figure 1).



**Figure 1.** Initial compounds.

Two routes for formation of polytopic *rctt* resorcinarenes built on the combined use of step-by-step modification of macrocycles **1a-c** by reagents containing fragments capable of transformation at subsequent stage, were considered. The first route (Figure 2, I) includes three stage: O-alkylation of resorcinarenes **1a,b** by propargyl bromide (*i*), catalytic cycloaddition of ethyl azido acetate to alkynes **2a,b** (*ii*) and transformation of terminal ester fragments associated with triazole moieties (*iii*, *iv*). Octa- and tetra-carboxy-resorcinarenes **5a,b** demonstrated receptor abilities toward biologically active amines by formation of supramolecular systems with various composition.



**Figure 2.** Routes of the formation of hybrid systems.

The second route (Figure 2, II) based on modification of tetraphosphito-tetrahydroxy-resorcinarene **1c**. On the first stage, P-alkylation (*i*) leads to the phosphinane rings opening and formation of phosphonate **6**. Then terminal halogen atoms are replaced by azide groups (*ii*) and formed products **7** are introduced into reaction of azide-alkyne cycloaddition with methyl butyldicarboxylate and 2-(propargyloxy)naphthalene (*iii*).

Further stepwise modification of terminal groups in triazoles **4,8** leads to formation of dendrimer-like structures containing 8 heterotopic branches located in two plane or 4 branches in only vertically plane (I route), and dendrimer systems with polyfunctional sites located in only horizontal plane (II route). Combination and position of functional sites immobilized on resorcinarene core determine their acceptor abilities toward metal cations and biologically active amines.

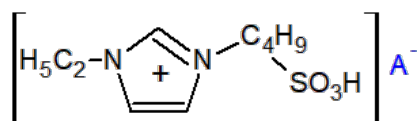
### References

- [1] Glushko V.V., Serkova O.S., Maslennikova V.I. *Tetrahedron Lett.* **2020**, *61*, 151418  
[2] Serkova O.S., Glushko V.V., Toropygin I.Yu., Maslennikova V.I. *ChemistrySelect* **2020**, *5*, 12168

*Gorbunov V.S.<sup>1</sup>, Tarkhanova I.G.<sup>1</sup>*

<sup>1</sup>Moscow State University, Moscow, Russia  
PhD-Student  
[vladisl4v.g@ya.ru](mailto:vladisl4v.g@ya.ru)

The continuous growth in the production of sulfur and high-sulfur oils requires the development of new approaches to solving the problem of desulfurization of crude oil. Along with hydrotreating, oxidative desulfurization - a process that combines the oxidation of organosulfur components of fuels with the subsequent extraction of their conversion products - is important [1]. The catalysts for this process are inorganic and organic acids, as well as oxides and oxometallates of transition metals. Heterogeneous systems are promising, in which ionic liquids (IL) supported on mineral carriers are used, containing the indicated catalytic centers in the cationic and / or anionic part [2]. Such compositions combine the advantages of heterogeneous catalysts and adsorbents. From the point of view of environmental safety, catalytically active "metal-free" ILs, which contain Bronsted acid sites, in particular, derivatives of imidazolium and strong acids, have an advantage. Thus, the aim of this work was to form heterogeneous catalysts based on derivatives of imidazolium sulfonate and sulfuric, formic, or acetic acids (Fig. 1) for the oxidation of organosulfur compounds with hydrogen peroxide and desulfurization of diesel fuel. In addition, the studies performed allowed a comparative analysis of the acid properties, as well as the activity and stability of the obtained compositions.



**Figure 1.** Structure of catalysts. Where A<sup>-</sup> is HCOO<sup>-</sup>, CH<sub>3</sub>COO<sup>-</sup>, -HSO<sub>4</sub>

Thiophene, dibenzothiophene, and thioanisole, as well as a diesel fraction containing 1080 ppm sulfur, were used as model substrates.

The composition and structure of the synthesized modified ILs were established using a set of physicochemical methods, including IR spectroscopy, SEM-EDA, adsorption studies, and elemental analysis. Gas-liquid chromatography and X-ray fluorescence analysis were used to research the reaction solutions. When analyzing the spectra of betaine and its derivatives, it was found that the protonation of the sulfo group with all acids occurs during the synthesis. This is evidenced by the appearance of an absorption band at 880 cm<sup>-1</sup>, which refers to the vibrations of the S-OH bond of the SO<sub>3</sub>H group in sulfonic acids. After deposition on silica gel, the samples were analyzed by adsorption methods and SEM-EDA, which made it possible to evaluate the effect of the content of the active phase on their textural characteristics. Using IR spectroscopy, it was found that the sulfuric acid catalysts contain the initial IL, while the derivatives of organic acids are mainly mixtures rather than individual Bronsted ionic liquids on the surface. The Bronsted character of acid sites and their number on the surface were determined by IR spectroscopy of adsorbed pyridine.

In catalytic experiments, the influence of the nature and content of the active phase on their properties in the oxidation of test substrates was determined. The activity of the catalysts correlates with the strength of the starting acids and the amount of the active phase on the surface. When processing of the diesel fraction, it was possible to reduce the sulfur content in sample to less than 10 ppm, as required by modern environmental standards. Catalysts based on sulfuric acid turned out to be more effective.

Thus, we have obtained a series of catalysts that are derivatives of formic, acetic and sulfuric acids and sulfobetaine - 4- (3'-ethylimidazolium) -butanesulfonate, immobilized on silica gel. The advantage of such catalytic systems is the absence of transition metals, as well as the presence of catalytically active acidic centers of the Bronsted nature in the surface layer, which combines the properties of a catalyst and an adsorbent. The conditions for the desulfurization of the diesel fraction to a residual sulfur content of less than 10 ppm have been determined.

### References

- [1] Rajendran A., Cui T., Fan H., Yang Z., Feng J., Li W. *J. Materials Chemistry A*. **2020**, 2246–2285  
[2] Tarkhanova I.G., Bryzhin A.A., Gantman M.G., Yarovaya T.P., Lukiyanchuk I.V., Nedozorov P.M., Rudnev V.S. *Appl. Catal. B Environ.* **2019**, 257, 117938

Acknowledgements. This work was performed using equipment purchased under the Moscow University Development Program.



STUDY OF THE BIOLOGICAL ACTIVITY OF POLYHEXAMETHYLENE GAUANIDINE AND COMPARISON OF THE BIOCIDAL PROPERTIES DEPENDING ON THE INFLUENCE OF THE DEGREE OF POLYCONDENSATION ON THE STRUCTURE OF THE STUDIED SUBSTANCES

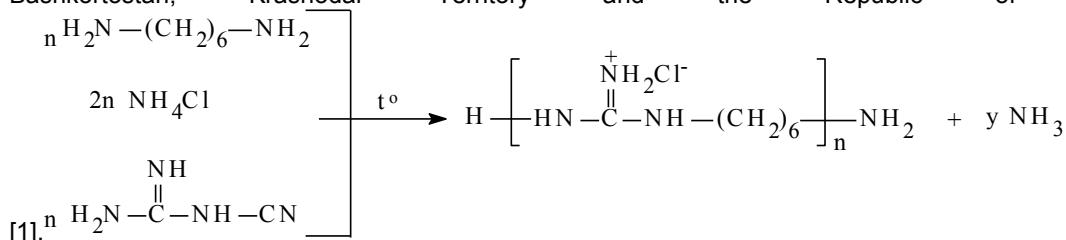
*Gurevich V.A., Strunina I.B., Shamsutdinova L.P., Gurevich P.A., Strunin B.P.*

Kazan National Research Technological University, Kazan, Russia

Student

[gureevich95@mail.ru](mailto:gureevich95@mail.ru)

It is known that polyhexamethyleneguanidines exhibit a variety of biocidal properties. In the work of Strunina a pilot plant with a closed cycle for the production of polyhexamethyleneguanidine hydrochloride using a waste product - ammonia - to produce a nitrogen fertilizer - ammonium sulfate was created. "Roxacin" is a 20% aqueous solution of PHMG. Extensive production tests of Roxacin were also conducted, which confirmed its high efficiency and favorable toxicological characteristics, allowing the use of the drug for therapeutic prophylaxis of the objects of Rosselkhoznadzor (in the Republic of Bashkortostan, Krasnodar Territory and the Republic of Adygea)



**Figure 1.** Reaction.

The Department of Organic Chemistry of KNRTU conducted a prediction of biological activity and toxicity using the platform <http://way2drug.com/PassOnline/> PGMG with different degrees of polycondensation.

Table 1. Results

Degree of polycondensation, n	Biological Activity (Pass Online) Atnfungal/Antibacterial	Toxicity class. (GUSAR) Intraperitoneal injection(IP)	Fungicidal effect. (Pass Online) Yeast Clavispora lusitaniae	Antibacterial (Pass Online) -RESISTANT Stenotrophomonas maltophilia
1	0,298/0,275	Class 4	0,3698	0,935
3	0,330/0,305	Class 4	0,3435	0,9638
5	0,330/0,305	Class 5	0,3435	0,9638
7	0,330/0,305	Class 5	0,3435	0,9638

It was found experimentally that the optimal antibacterial properties are distinguished by PGMG with an average degree of polycondensation  $n = 10$ . Thus, testing carried out by the method of serial dilutions showed that the highest activity in the concentration of 1.9 mg/ml against St.aureus PGMG showed the highest activity at the average degree of polycondensation 10.

The test results of biological activity of the preparation: it is low-toxic, has class 4 hazard, is not an allergen; it can be used for treatment of Vetzanadzor facilities (pigsties, barns, etc.); it has fungicidal and antibiotic effect against wheat root rot pathogens, microorganisms *Fusarium oxysporum*, *Bipolaris sorokiniana*, *Penicillium lividum*, *Pseudomonas* sp.

The results of computer prediction correlate with the experimental data.

#### References

[1] Strunina, Irina Borisovna. A single-stage method for the preparation of polyhexamethylene guanidine hydrochloride, a broad-spectrum biocide : dissertation ... candidate of Technical Sciences: 02.00.03 / Strunina Irina Borisovna; [Place of defense: Kazan National Research Technological University].- Kazan, 2011. - 179 p.

SYNTHESIS AND STUDIES OF DETECTION ABILITY OF TRIS(3-AMINOPROPYL)AMINE  
AND TRIS(2-AMINOETHYL)AMINE DERIVATIVES

*Gusev D.I.<sup>1</sup>, Kuliukhina D.S.<sup>2</sup>, Averin A.D.<sup>2</sup>, Beletskaya I.P.<sup>2</sup>*

<sup>1</sup> D.Mendelev University of Chemical Technology of Russia, Moscow, Russia

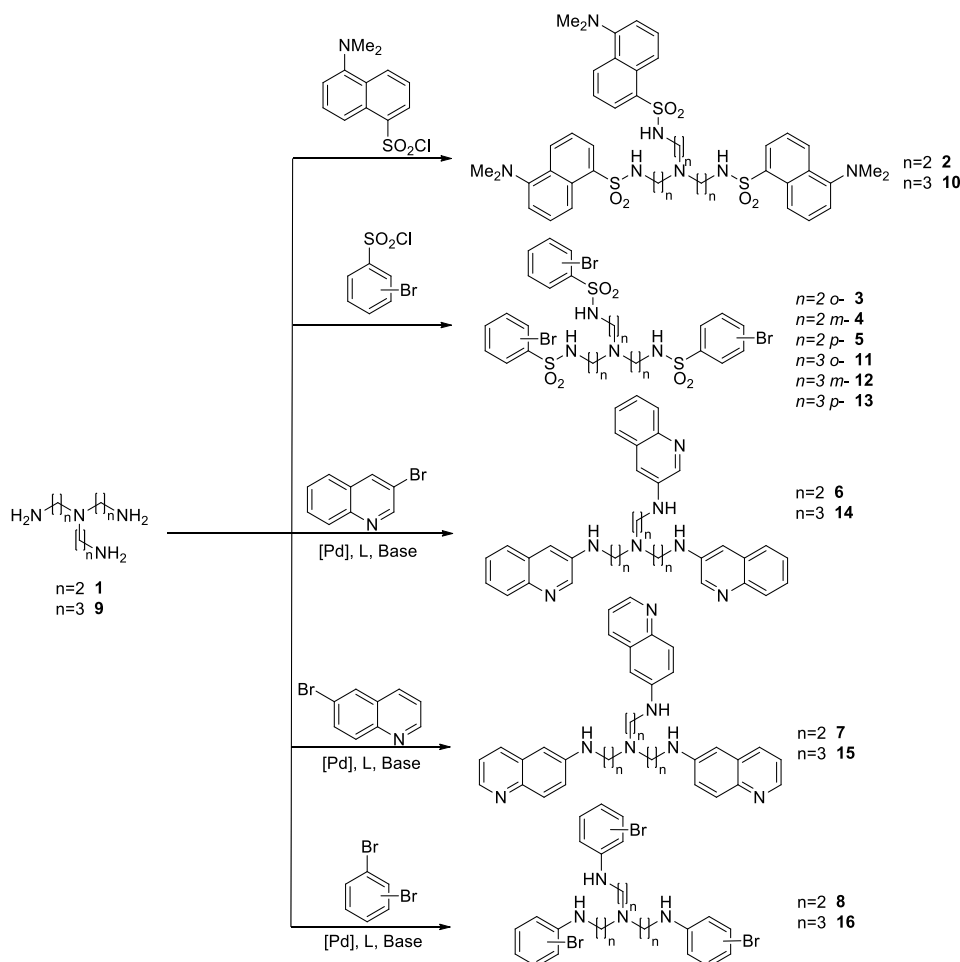
<sup>2</sup> M.V. Lomonosov Moscow State University, Moscow, Russia

Student

[danya.gusev@gmail.com](mailto:danya.gusev@gmail.com)

One of the actual tasks of modern chemistry is the search for highly sensitive and reliable methods for detection and recognition of various charged and neutral analytes like metal cations, anion species, and enantiomers of small chiral organic molecules. One of these methods employs coordination ability of the compounds with fluorescent properties which results in the changes in the absorption and emission spectra. This approach is being under rapid development in the laboratory of organoelement compounds at the Department of Chemistry of the Lomonosov MSU.

In the present work novel derivatives of tris(3-aminopropyl)amine and tris(2-aminoethyl)amine each bearing three aryl- or heteroaryl substituents were synthesized using catalyst-free and Pd(0)-catalyzed amination reactions (Fig. 1). The regularities of the catalytic reactions depending on the nature of the starting compounds were studied, the possibility of the Pd(0)-catalyzed macrocyclization reactions involving bromophenyl and dansyl substituted tetraamines was investigated. The target compounds possess bromophenyl, dansyl, 3- and 6-quinolinyl substituents thus providing perspective receptors for metal cations with fluorophore groups.



**Figure 1.** Synthetic paths applied for the synthesis of tetraamine derivatives.

The synthesized compounds were studied as molecular detectors by UV- and fluorescence spectroscopy. The detection ability of the compounds was investigated using 21 metal cations.

Acknowledgement. This work was supported by the Russian Foundation for Basic Research (project No 18-03-00709).

SYNTHESIS, ANTIOXIDANT AND ANTIBACTERIAL EVALUATION OF SCHIFF BASES DERIVED FROM 4,6-DI-*TERT*-BUTYL-2,3-DIHYDROXYBENZALDEHYDE

*Gvozdev M.Y.*<sup>1</sup>, *Loginova N.V.*<sup>2</sup>, *Ksendzova G.A.*<sup>2</sup>, *Osipovich N.P.*<sup>2</sup>, *Koval'chuck T.V.*<sup>1</sup>, *Khodosovskaya A.M.*<sup>1</sup>

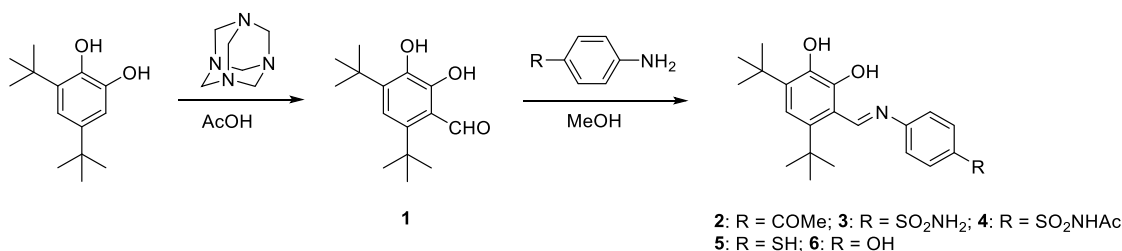
<sup>1</sup>Belarusian State University, Minsk, Belarus

<sup>2</sup>Research Institute for Physical Chemical Problems, Minsk, Belarus

Student

[loginov@gmail.com](mailto:loginov@gmail.com)

The increasing microbial resistance to antibiotics necessitates the search of novel antibacterial agents. Schiff bases are an important class of organic compounds finding application in different fields of industry, catalysis and drug design due to the ease of synthesis and possibility to generate vast libraries of structurally diverse molecules with unique properties [1]. Phenolic compounds were found to be potent against fungi, bacteria, viruses and protozoa. They are also able to slow down oxidation processes. Thus, combination of antioxidant and antimicrobial properties allows one to consider phenolic Schiff bases as promising agents for biomedical application.



**Figure 1.** Synthesis of Schiff bases.

Schiff bases were prepared from 4,6-di-*tert*-butyl-2,3-dihydroxybenzaldehyde and aromatic amines (Figure 1). They were characterized by means of NMR, FT-IR, UV-vis and MS. Antioxidant activity was measured using DPPH radical and ABTS cation radical according to the procedure described previously [2]. The compounds under study were screened *in vitro* against Gram-positive bacteria (*Staphylococcus aureus*, *Bacillus subtilis*) and Gram-negative bacteria (*Pseudomonas putida*, *Escherichia coli*). The antimicrobial activity was determined as the lowest concentration of the compound which inhibits the visible microbial growth. The results obtained are discussed in the context of presumed interconnection of their antimicrobial activity and redox properties. It was found that all the compounds under study possess antiradical and antimicrobial activity, which significantly depends on the nature of the substituent.

#### References

- [1] Da Silva C.M., Da Silva D.M., Modolo L.V., Alves R.B., Resende M.A., Martins C.V.B., Fatima A. *J. Adv. Res.* **2011**, 2, 1–8  
[2] Jasprica I., Bojic M., Mornar A., Besic E., Bucan K., Medic-Saric M. *Molecules* **2007**, 12, 1006-1021

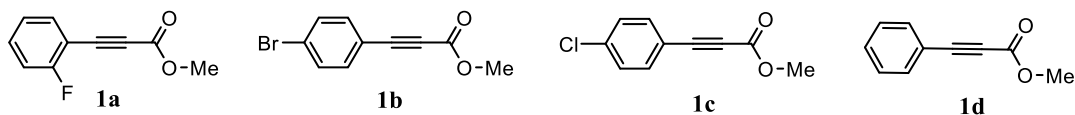
<sup>1</sup>Saint Petersburg State University, Saint Petersburg, Russia<sup>2</sup>Saint Petersburg State Forest Technical University, Saint Petersburg, Russia

Student

[north.irina@yandex.ru](mailto:north.irina@yandex.ru)

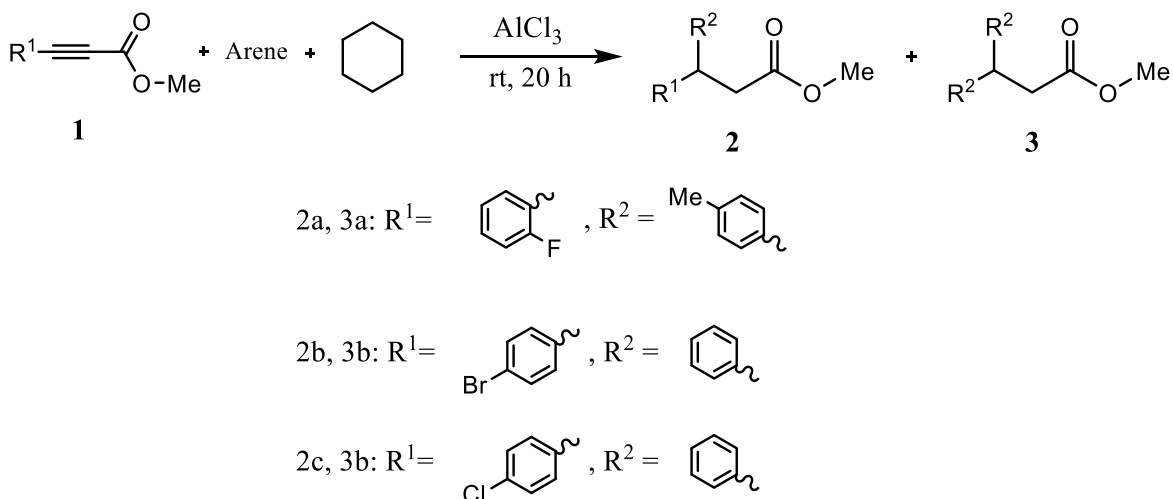
In recent years a method of tandem hydroarylation - ionic hydrogenation of the acetylene bond has been developed [1]. The compounds obtained by this method, esters of diarylpropanoic acids, can be used as substrates for synthesis of alkyl glycerone phosphate synthase inhibitors [2]

The aim of this research was a study of tandem hydroarylation-ionic hydrogenation of esters of 3-arylpropynoic acids **1a-d** (Figure 1) under superelectrophilic activation.



**Figure 1.** Starting compounds used in this study.

The reaction of esters **1** with benzene and cyclohexane under the action of  $\text{AlCl}_3$  resulted in mixture of compounds **2**, **3** (Scheme 1). Esters **3** are products of aryl group exchange under superelectrophilic reaction conditions.



Ester	Arene	Reaction product (Yield, %)	
<b>1a</b>	Toluene	<b>2a</b> (13%)	<b>3a</b> (6%)
<b>1b</b>	Benzene	<b>2b</b> (23%)	<b>3b</b> (14%)
<b>1c</b>	Benzene	<b>2c</b> (22%)	<b>3b</b> (21%)

**Scheme 1.** Tandem hydroarylation-ionic hydrogenation of compounds **1**.

### References

- [1] D.I.Nilov, A.V. Vasilyev. One-pot tandem hydrophenylation and ionic hydrogenation of 3-phenylpropynoic acid derivatives under superelectrophilic activation. *Tetrahedron letters*, **2015**, V. 56, № 42, P. 5714-5715
- [2] G. Stazi, C. Battistelli, V. Piano, R. Mazzone, B. Marrocco, S. Marchese, S. M. Louie, C. Zwergel, L. Antonini, A. Patsilinakos, R. Ragno, M. Viviano, G. Sbardella, A. Ciogli, G. Fabrizi, R. Cirilli, R. Strippoli, A. Marchetti, M. Tripodi, D. K. Nomura, A. Mattevi, A. Mai, S. Valente, Development of alkyl glycerone phosphate synthase inhibitors: Structure-activity relationship and effects on ether lipids and epithelial-mesenchymal transition in cancer cells, *European Journal of Medicinal Chemistry*, **2019**, V. 163, P. 722-735

Acknowledgements. This work was supported by the Russian Science Foundation (project No 21-13-00006).

SYNTHESIS OF POLYSUBSTITUTED SEVEN-MEMBERED SYSTEMS VIA CASCADE REACTIONS OF (DI(METHOXYCARBONYL)VINYLPYRIDINIUM

*Ilyushchenko M. K.<sup>1,2</sup>, Salikov R. F.<sup>2</sup>, Tomilov Yu. V.<sup>2</sup>*

<sup>1</sup>Moscow State University, Moscow, Russia

<sup>2</sup>N. D. Zelinsky Institute of Organic Chemistry, Russian Academy of Sciences, Russia

Student

[motissyat@gmail.com](mailto:motissyat@gmail.com)

Cascade reactions are a potent tool in organic synthesis as they construct intricate structures in one reaction step employing simple starting molecules. Hepta(methoxycarbonyl)cycloheptatriene **1** (Fig.1) is available from a cascade reaction of N-(methoxycarbonylmethyl)pyridinium electrophilic vinylpyridinium **2** generated *in situ* from pyridine and dimethyl bromomaleate [1] and the only example of a similar reaction is the formation of octasubstituted cycloheptadiene **3** in the reaction of **2** with dimethyl malonate [2]. Other methods do not afford cycloheptatrienes with more than five acceptor groups, therefore **1** is still the sole electron-deficient cycloheptatriene available so far.

The diverse reactivity of **1** investigated in the past decade makes other electron-deficient cycloheptatrienes attractive [3]. The cyano group seemed to be easiest to incorporate into the product by varying the starting reagents. However, numerous attempts to use CH-acid fragments with cyano groups did not afford the target molecules. Thus, the reaction of malononitrile with **2** terminated after addition of two vinyl fragments to give zwitterion **4**, which was quite unreactive and stable presumably due to high anion-stabilizing effect of the two cyano groups. Similarly, the reaction of N-(cyanomethyl)pyridinium gave a mixture of undesired products. Such the difference between ester and nitrile substrates shows that the key condition for the successful formation of the product is the lower stability of anionic centers in intermediates.

We proposed that trisubstituted propenes can be used as CH-acid component in the cascade reaction. The reaction of trimethylacetonate with **2** lead to the formation of cycloheptadiene moiety **5**, which can be converted to bicycloheptene **6** with bases or cycloheptatriene **1** by oxidation. Notably, cycloheptadiene was found to be oxidized to cycloheptatriene even in the presence of a base and in air. Experiments with dimethyl (cyanomethylidene)succinate gave slightly different results. In that case only bicycloheptene product **7** was produced, since cyano group is stronger acceptor in comparison with ester group, and, as a result, reaction product has higher potency for intramolecular ring-contraction.

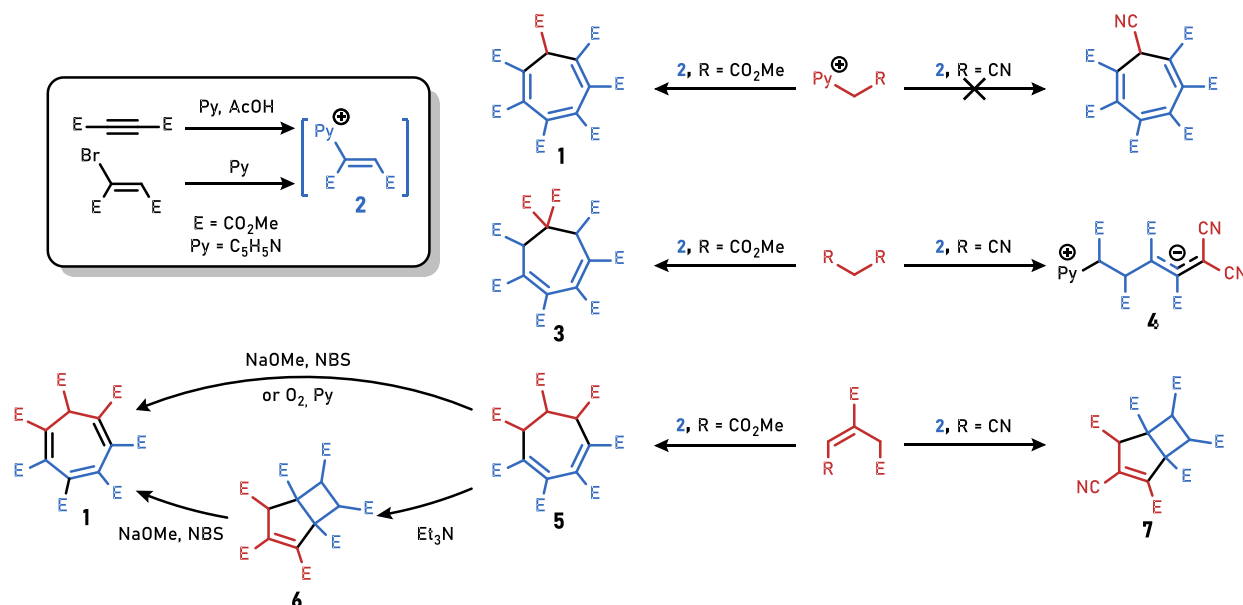


Figure 1. Reactions of vinylpyridinium **2** with different CH-acids.

### References

- [1] Belyy A. Y., Platonov D. N., Salikov R. F., Levina A. A., Tomilov Y. V. *Synlett* **2018**, 29 (9), 1157–1160  
 [2] Salikov R. F., Trainov K. P., Platonov D. N., Belyy A. Y., Tomilov Y. V. *Eur. J. Org. Chem.* **2018**, 2018(36), 5065-5068.  
 [3] Belyy A. Y., Platonov D. N., Salikov R. F., Trainov K. P., Medvedev M. G., Luponosov Y. N. et al. *Dyes Pigm.*, **2021**, 187, 109107.

## SYNTHESIS OF 4-POLYFLUOROARYLTHIAZOLES

*Kalashnikov S.B.*<sup>1</sup>, *Vinogradov A.S.*<sup>2</sup>

<sup>1</sup>Novosibirsk State University, Novosibirsk, Russia

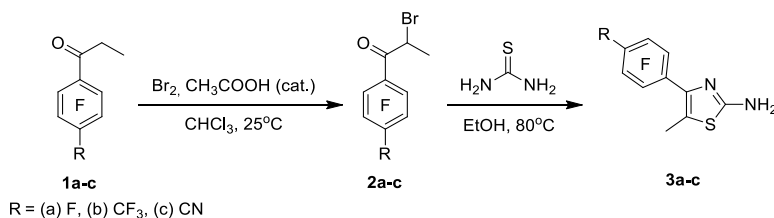
<sup>2</sup>N.N. Vorozhtsov Novosibirsk Institute of Organic Chemistry  
SB RAS, Novosibirsk, Russia

Student

[vas@nioch.nsc.ru](mailto:vas@nioch.nsc.ru)

The thiazole moiety is a structural fragment of many drugs such as abafungin, aminitrozole, ceftazidime, cefdinir, famotidine, norsulfazole. At the same time, fluorine-containing compounds have a wide range of biological activity [1]. Thus, the synthesis of thiazoles with fluorine-containing substituents has a current interest.

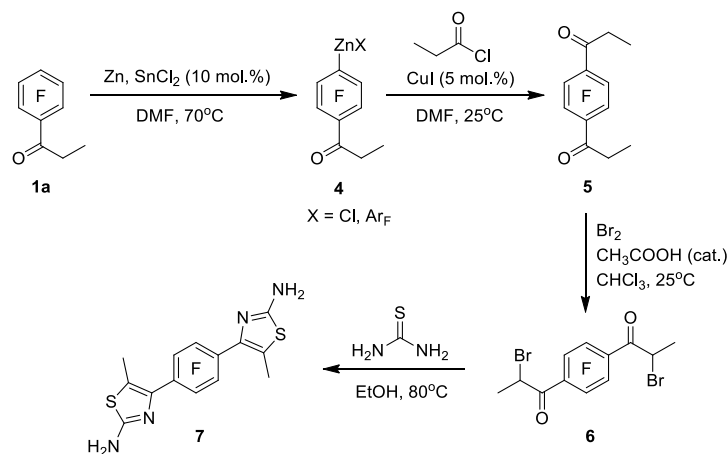
We have shown that the reaction of polyfluoropropiophenones **1a-c** with bromine in the presence of catalytic amounts of acetic acid in chloroform leads to the corresponding 2-bromopropiophenones **2a-c**. The latter products were treated with thiourea in ethanol to yield 2-amino-5-methyl-4-polyfluoroarylthiazoles **3a-c** (Figure 1).



**Figure 1.** Reaction of polyfluoropropiophenones **1a-c** with bromine and synthesis of 2-amino-5-methyl-4-polyfluoroarylthiazoles **3a-c**.

Polyfluoropropiophenones **1a-c** were prepared by interaction of propionyl chloride with polyfluoroarylzinc compounds [2].

It was found that ketone **1a** reacts with zinc in the presence of SnCl<sub>2</sub> in DMF giving organozinc compounds **4**, which were converted into 1,4-dipropionyltetrafluorobenzene **5** under the action of propionyl chloride in the presence of CuI. 1,4-Di(2-amino-5-methylthiazol-4-yl)tetrafluorobenzene **7** was obtained by bromination of diketone **5** and subsequent reaction of the forming dibromoethyl ketone **6** with thiourea (Figure 2).



**Figure 2.** Synthesis of 1,4-di(2-amino-5-methylthiazol-4-yl)tetrafluorobenzene **7**.

To summarize, the series of new polyfluorinated 2-bromopropiophenones and 4-arylthiazoles were synthesized.

### References

- [1] Fluorine in Medicinal Chemistry and Chemical Biology. Ed.: I. Ojima. Chichester. **2009**. P. 640  
[2] Vinogradov A.S., Krasnov V.I., Platonov V.E. *Russ. J. Org. Chem.* **2010**, *46*, 344-351

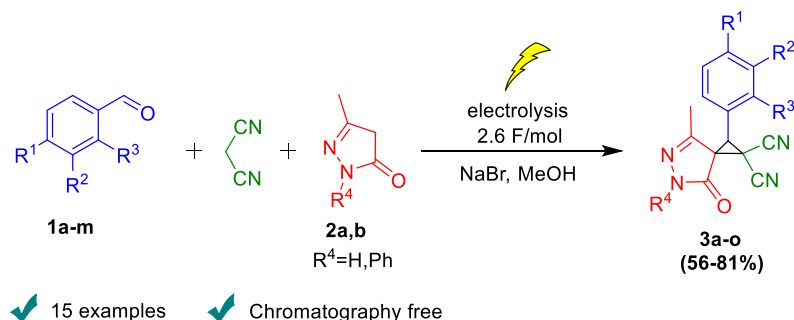
ELECTROCATALYTIC ASSEMBLING OF SUBSTITUTED BENZALDEHYDES,  
MALONONITRILE AND PYRAZOLIN-5-ONES

*Kalashnikova V.M.*<sup>1,2</sup>, *Ryzhkova Y.E.*<sup>2</sup>, *Elinson M.N.*<sup>2</sup>

<sup>1</sup>D.Mendeleev University of Chemical Technology of Russia, Moscow, Russia  
<sup>2</sup>Institute of Organic Chemistry, Russian Academy of Sciences, Moscow, Russia  
Student  
p.varvara2001@gmail.com

The cyclopropyl fragment is an important structural unit in many synthetic and naturally occurring compounds having a wide spectrum of biologic properties, ranging from enzyme inhibition to herbicidal, antibiotic, antitumor and antiviral activities [1-4]. The spirocyclopropyl moiety jointed with a heterocyclic fragment has also aroused a special interest because of the wide range of pharmacological applications of such compounds. Fused spirocyclopropyl heterocycles have anti-AIDS and anti-autoimmune properties [6]. Similar compounds are also effective agents against nitrogen-fixing fungi [7]. Another spirocyclopropyl pyrazolone applies for treatment of human's schizophrenia [8]. Thus, compounds with spiro connection cyclopropane and pyrazolin-5-one scaffolds are promising substance for different applications.

Our present study deals with the selective and facile electrocatalytic assembling of aldehydes **1a-m**, malononitrile and pyrazolin-5-ones **2a,b** into substituted spirocyclopropyl pyrazolones **3a-o** in methanol in the an undivided cell after 2.6 F/mol of electricity passed (Scheme 1).



**Scheme 1.** Electrocatalytic multicomponent assembling of arylaldehydes **1a-m**, malononitrile and pyrazolin-5-ones **2a,b**

Thus, the electrocatalytic multicomponent assembling of aldehydes **1**, malononitrile and pyrazoline-5-ones **2** in methanol in the presence of sodium bromide as mediator in an undivided cell results in the formation of the substituted spirocyclopropyl pyrazolones **3** in 56-81% yields. This electrocatalytic efficient process involves the use of simple equipment and available mediator - sodium bromide. It is easily carried out and the isolation procedure is simple filtering. Thus, such method could be used in pharmaceutical industry to produce chip and available structures with high biological potential.

#### References

- [1] Rappoport, Z. *The Chemistry of the Cyclopropyl Group*; John Wiley and Sons: New York, **1996**
- [2] Yamaguchi, K.; Kazuta, Y.; Hirano, K.; Yamada, S.; Matsuda, A.; Shuto, S. *Bioorg. Med. Chem.* **2008**, *16*, 8875–8881.
- [3] Brackmann, F.; de Meijere, A. *Chem. Rev.* **2007**, *107*, 4538–4583.
- [4] Sandanayaka, V. P.; Prashad, A. S.; Yang, Y.; Williamson, R. T.; Lin, Y. I.; Mansour, T. S. *J. Med. Chem.* **2003**, *46*, 2569–2571.
- [5] Laroche, C.; Behr, J. -B.; Szymoniak, J.; Bertus, P.; Schutz, C.; Vogel, P.; Plantier-Royon, R. *Bioorg. Med. Chem.* **2006**, *14*, 4047–4054.
- [6] Jiang, T.; Kuhen, K. L.; Wolff, K.; Yin, H.; Bieza, K.; Caldwell, J.; B. Bursulaya, B.; Wu, T.; He, Y. *Bioorg. Med. Chem. Lett.* **2006**, *16*, 2105–2108.
- [7] Devi, S.; Nayak, A.; Mittra, A. S. *J. Indian. Chem. Soc.* **1984**, *61*, 640–642.
- [8] Itokawa, M.; Miyata, T.; Arai, M. Detection and treatment of schizophrenia. Eur. Pat. Appl. 2010, EP 2 189 537 A1.

Acknowledgements. This work was supported by the Russian Foundation for Basic Research (Project No. 19-29-08013).

## LIGNOSULFONATE-BASED CATALYST OF ALCOHOL DEHYDRATION

*Karimov O.Kh.<sup>1</sup>, Karimov E.Kh.<sup>2</sup>, Neklydov K.A.<sup>1</sup>, Benetashvili I.A.<sup>1</sup>*

<sup>1</sup>MIREA – Russian Technological University, Moscow, Russia

<sup>2</sup>Ufa State Petroleum Technological University, Ufa, Russia

Docent

karimov@mirea.ru

Lignosulfonates are derivatives of lignin. They are waste products from the pulp and paper industry and are formed in large quantities as a result of wood cooking (wood digestion). It is rather difficult to characterize lignosulfonates since they are a polydisperse system [1]. The macromolecule of lignosulfonates forms a nonlinear structure approaching the structure characteristic of globular polymers. A feature of the structure of lignosulfonates is that there are ionized sulfo groups inside the macromolecule giving it a negative charge.

The presence of cations on the surface of lignosulfonates is of interest from the point of view of their application in catalysis [2]. In this work, the possibility of using technical lignosulfonates in the dehydration reaction of tert-butyl alcohol was studied. This reaction is important for the industrial production of isobutylene. Polymers containing sulfonic acid groups  $\text{SO}_3^-$  are used as catalysts for alcohol dehydration reactions, which makes it attractive for considering the catalytic properties of lignosulfonates.

The work investigated the catalytic properties of sodium and sodium-ammonium salts of lignosulfonic acids with an admixture of reducing and mineral substances (technical lignosulfonates). Lignosulfonates both initial and modified with sulfuric acid were studied. The modified catalyst was prepared by impregnating the lignosulfonate with a solution of sulfuric acid and subsequent washing to remove excess acid.

The original technical lignosulfonate did not show catalytic properties in the dehydration reaction of tert-butyl alcohol, which is probably due to the influence of sodium cations in the polymer and low acidity of the medium. It is known that the treatment of lignosulfonates with sulfuric acid is carried out to increase the degree of sulfonating of the lignosulfonate. In the reaction of dehydration of tert-butyl alcohol, such a lignosulfonate modified with sulfuric acid actually demonstrated its catalytic properties.

We found that in the obtained catalyst samples the total static exchange capacity is up to 5.1 mmol/g. This value is comparable with the values of industrial catalysts (for example, cation exchangers of the KU-2-8, Purolite brand). However, the maximum yield of isobutylene was 42,3% during the catalyst operation. A possible reason for the low of activity is caused by the manifestation of the surface-active properties of lignosulfonates in an aqueous-alcoholic medium. Due to its polarity, water deactivates the catalyst by being adsorbed on active sites. The rapid loss of catalytic activity is probably also associated with thermochemical processes occurring in the lignosulfonate when heated in an acidic medium.

Thus, lignosulfonates exhibit catalytic properties in the reaction of tertiary alcohol dehydration only with increase in the degree of sulfonating, i.e. introducing additional  $\text{SO}_3\text{H}^+$  groups into the structure.

### References

- [1] Chetvertneva I.A., Karimov O.K., Teptereva G.A., Ismakov R.A. *Oil & Gas Chemistry* **2019**, 3, 35-40  
[2] Myrvold B.O. *Industrial Crops and Products* **2008**, 27 (2), 214-219

Acknowledgements. This work was supported by the "University Grant for Young Scientists RTU MIREA" (project No NICH-49).



TRANSAMINATION OF 1,1-DIMETHYL-3-(4-METHYLPYRIDIN-2-YL)UREA  
TO UNSYMMETRICAL *N*-METHYLPYRIDIN-2-YL-*N'*-ARYLUREAS

*Kasatkina S.O.*<sup>1</sup>, *Baykov S.V.*<sup>1</sup>, *Boyarskiy, V. P.*<sup>1</sup>

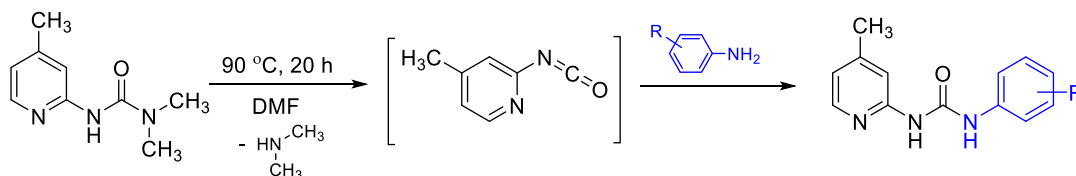
<sup>1</sup>Saint Petersburg State University, Saint Petersburg, Russia  
PhD student  
[s.kasatkina@spbu.ru](mailto:s.kasatkina@spbu.ru)

The diarylurea is a valuable moiety in discovery of new antitumor agents [1]. Among diarylurea, especially those containing a heteroaromatic fragment, compounds were found that inhibit of apoptosis signal-regulating kinase 1 [2], PI3Ka and mTOR kinases simultaneously [3], glycogen synthase kinase 3 and cyclin dependent kinase 5 [4].

Diarylurea synthesis methods can be divided into 4 groups. Three out of four are reactions of 2-aminoazines with arylisocyanates or phosgene surrogates or carbon monoxide. Obvious disadvantages of these methods are usage of difficult to obtain 2-aminoazines and toxicity, hazard, explosiveness of other reagents. Fourth method is direct arylation of *N,N*-unsubstituted-*N'*-arylureas. It includes halide-containing substrates and transition metal catalysis. Furthermore, recently base promoted domino approach from 2-aminopyridinium salts and arylamines has been developed [5]. However, these salts even more difficult to obtain than starting amines. In this regard, the development of new convenient routes for the preparation of diarylureas is highly desirable.

Recently, our group has developed a method for the synthesis of *N*-azinylcarbamates based on alcoholysis of corresponding *N,N*-dialkyl-*N'*-(azinyl)ureas. It was shown that this reaction proceeds through the formation of azinylisocyanate intermediates. The discovery that *N*-azinylureas can be considered as masked azinylisocyanates allowed us to extend our research to *N*-nucleophiles.

In this work, we have studied the reactivity of 1,1-dimethyl-3-(4-methylpyridin-2-yl)urea with a wide range of anilines. We have shown that dissolution of 1,1-dimethyl-3-(4-methylpyridin-2-yl)urea and the appropriate aniline in DMF and subsequent stirring of resulted solution for 20 hours at 90 °C gives the corresponding *N*-methylpyridin-2-yl-*N'*-arylureas. Various temperatures and solvents were tested to find the optimal reaction conditions. The structures of all compounds synthesized are confirmed by NMR and HR-MS. The structure of 1-(4-methylpyridin-2-yl)-3-phenylurea was also confirmed by X-ray diffraction. As a result, a convenient and simple protocol for *N*-methylpyridin-2-yl-*N'*-arylureas from *N*-pyridyl-*N,N*-dialkylurea preparation has been developed.



**Figure 1.** Transamination of 1,1-dimethyl-3-(4-methylpyridin-2-yl)urea with anilines.

### References

- [1] Garuti, L., Roberti, M., Bottegoni, G., & Ferraro, M. *Curr Med Chem.* **2016**, 23, 1528–1548
- [2] Zhang, S., Huang, C., Lyu, X., Wang, P., Zang, Y., Wang, Z. et al. *Eur. J. Med. Chem.* **2020**, 195, 112277
- [3] Lei, F., Sun, C., Xu, S., Wang, Q., OuYang, Y., Chen, C. et al. *Eur. J. Med. Chem.* **2016**, 116, 27–35
- [4] Boulahjar, R., Ouach, A., Bourg, S., Bonnet, P., Lozach, O., Meijer, L. et al. *Eur. J. Med. Chem.* **2015**, 101, 274–287
- [5] Patel, O. P., Rangan, K., & Kumar, A. *Tetrahedron Lett.* **2019**, 60, 150939

Acknowledgements. This work was supported by the Russian Science Foundation (project No 19-13-00008). All physicochemical measurements were performed at the Research Park of Saint Petersburg State University (Center for Magnetic Resonance, Center for Chemical Analysis and Material Research, and Center for X-ray Diffraction Methods).

# SYNTHESIS AND SPECTROSCOPIC PROPERTIES OF TETRA-4-(2/4-CYCLOHEXYLPHENOXY) PHTHALOCYANINES

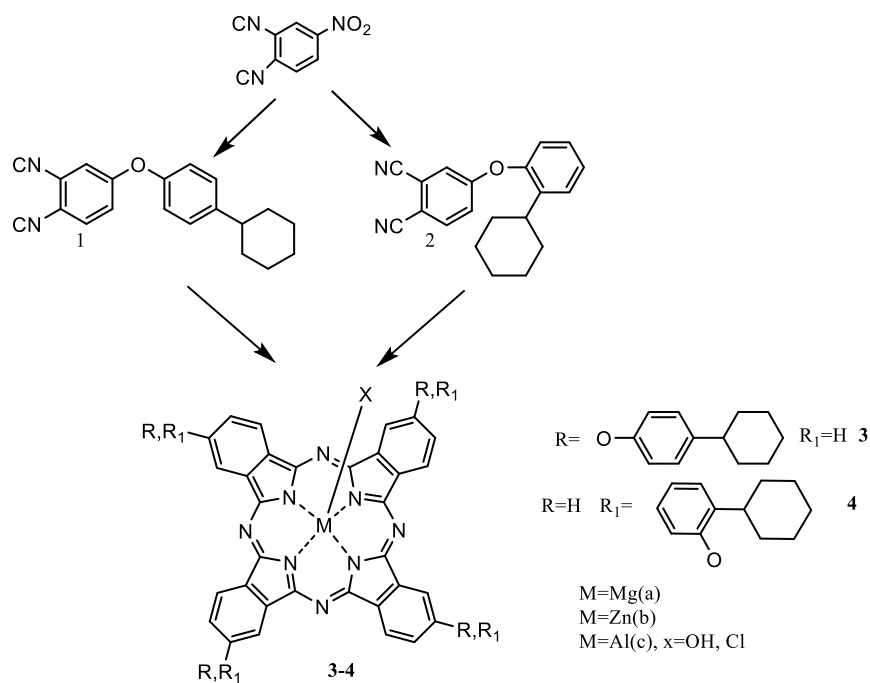
*Kazaryan K. Y., Tikhomirova T.V., Botnar A.A., Vashurin A.S.*

Ivanovo State University of Chemistry and Technology, Sheremetevsky ave., 7, Ivanovo, Russia, 153000  
[kristina@kazaryan.ru](mailto:kristina@kazaryan.ru)

Complexes of phthalocyanines with metals are known as compounds with promising properties such as high chemical and thermal stability, as well as unique optical and electrical ones. The nature of the central metal ion and substituents are a tool for fine-tuning the physicochemical characteristics of compounds. The disadvantages of phthalocyanines associated with low solubility and a tendency to aggregation can be overcome by chemical modification of the macrocycle periphery by introducing phenoxy- substituents.

In this regard, this work is devoted to the synthesis and study of spectroscopic properties of metal complexes with zinc, magnesium and aluminum phthalocyanines containing cyclohexylphenoxy- groups at the periphery.

One of the simple and effective methods for obtaining phthalocyanines is a nitrile one. Initially, 2-cyclohexylphenoxy- (1) and 4-cyclohexylphenoxy phthalonitriles (2) were obtained, which afterward being used for the synthesis of phthalocyanines and their metal complexes (3-4) with magnesium, zinc and aluminum. Metal complexes synthesis were carried out by template fusion of substituted nitriles (1,2) with appropriate metal salts at 180-190 °C. (Scheme 1).



All synthesized compounds were isolated and purified using column chromatography.

The identity of all the compounds obtained characterized by <sup>1</sup>H NMR, IR spectroscopy and elemental analysis.

Due to the good solubility of the synthesized complexes (3-4) in organic solvents, their spectral properties were studied. The effect of the nature of the metal, the location of the cyclohexyl fragment in the substituent and solvent on the position of the main band and the behaviour of the spectral curves is shown.

Acknowledgements. This work was carried out with the financial support of the Russian Science Foundation (Grant No. 17-73-20017) using the resources of the Center for Collective Usage of the ISUCT.

## LYSOZYME FIBRIL DISRUPTION WITH POLYSACCHARIDES

*Khaibrakhmanova D.R.*<sup>1,2</sup>, *Makshakova O. N.*<sup>2,3</sup>, *Sedov I.A.*<sup>1,2</sup>

<sup>1</sup>Kazan Federal University, Kazan, Russia

<sup>2</sup>Sirius University of Science and Technology, Sochi, Russia

<sup>3</sup>Kazan Institute of Biochemistry and Biophysics, Kazan, Russia

PhD Student

diliara.khaibrakhmanova@gmail.com

### Introduction:

Formation of amyloid fibrils in human organism is one of the main causes of neurodegenerative diseases, including Alzheimer's disease. Development of the methods to inhibit the formation of amyloids or disrupt already formed fibrils is an important task in life sciences.

Lysozyme is one of the common model proteins to study amyloid fibril formation. Lysozyme readily forms fibrils at acidic pH values and elevated temperature. Atomic force microscopy (AFM) is a powerful instrument allowing to visualize fibrils and analyze their size and morphology. In the present study, the AFM method was used to study the effect of polysaccharides chitosan and kappa-carrageenan on lysozyme fibrils.

Methods: Lysozyme fibrils were obtained by incubating a 30 mg/ml protein solution at pH 1.7-2.0 and temperature 65°C for 7 days with stirring. The precipitate was separated by dialysis, and a solution containing fibrils with total protein concentration approximately 5 mg/ml was used in further studies.

Chitosan and kappa-carrageenan were added to the solution containing fibrils at polysaccharide:protein ratio 1:3 by mass. Kappa-carrageenan formed a coacervate upon addition, which was separated. The addition of chitosan did not cause precipitation. The solutions were diluted 20 times. For AFM measurements, the droplets of solutions were placed onto a mica piece and dried.

Results: The average fibril diameter is about 6 nm and the typical length is from 200 to 1000 nm. The AFM images of pure fibril solution and after addition of polysaccharide showed remarkable differences. Partial destruction of fibrils was observed upon addition of chitosan: a lot small round particles appear in the image, while the number of fibrils decreases. After addition of kappa-carrageenan, no fibrils is observed.

### Conclusions

We have shown that oligosaccharides can be used to destroy amyloid fibrils. Kappa-carrageenan destroys them completely, while chitosan causes their partial disaggregation.

Acknowledgements. This work was supported by the Russian Foundation for Basic Research (project No 19-315-51012).

## A METAL-FREE SYNTHESIS OF DIVERSE HETEROCYCLES

*Khamraev V.F.<sup>1</sup>, Kovaleva L.S.<sup>1</sup>, Lazareva E.Yu.<sup>1</sup>*

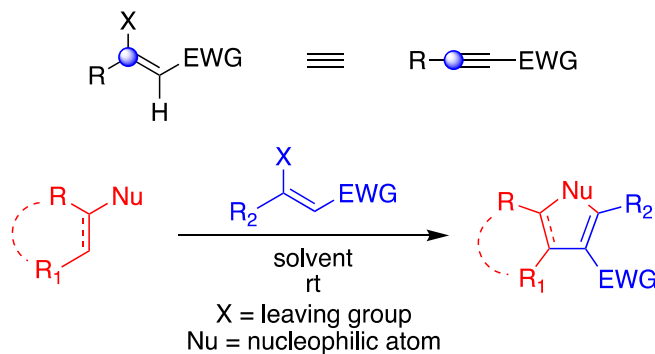
<sup>1</sup>Mendeleev University of Chemical Technology of Russia, Moscow, Russia

PhD Student

vkhamraev@muctr.ru

Pyrazolopyridines (PP) are a class of fused heteroaromatic bicyclic compounds paid considerable attention towards chemistry and biology as a privileged structural unit.

In the present research a new synthetic approach to indole, pyrazolopyridine, pyrroles, indolizine and other bioactive heterocycles possessing biological activity was developed [1].



**Figure 1.** Reaction conditions.

The reaction proceeds without any catalyst at room temperature and mild conditions.

### References

[1] A. Subbarayappa, C. Darapaneni, C. Ravi and N. K. R. N, *RSC Advances* **2015**, *5*, 42961-42964.

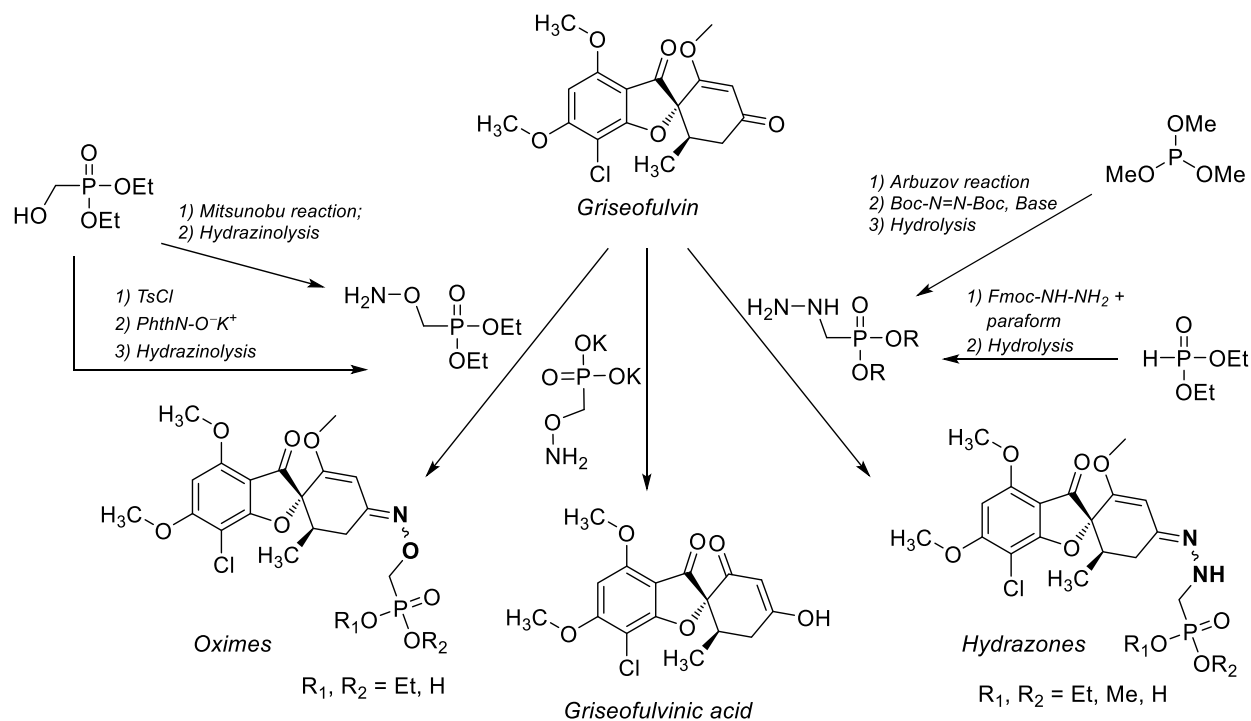
# SYNTHESIS OF WATER-SOLUBLE DERIVATIVES OF GRISEOFULVIN

*Khislamov M.M.*<sup>1,2</sup>, *Solyev P.N.*<sup>2</sup>, *Kochetkov S.N.*<sup>2</sup>

<sup>1</sup>Lomonosow Moscow State University, Moscow, Russia  
<sup>2</sup>Engelhardt Institute of Molecular Biology, Moscow, Russia  
 Student  
[marat.khislamov@chemistry.msu.ru](mailto:marat.khislamov@chemistry.msu.ru)

Griseofulvin is a compound with a wide range of pharmacological uses due to its fungistatic properties. However, the use of griseofulvin in pharmacology is limited by its low water solubility and, as a consequence, its low oral bioavailability. Solubility of griseofulvin can be improved by creating its water-soluble prodrugs. Oximes and hydrazones based on aminoxyethylphosphonic and hydrazinomethylphosphonic acids can be regarded as convenient click reagents for this task. We have studied several routes of their synthesis. Aminoxyethylphosphonates were obtained in the standard Mitsunobu procedure with *N*-hydroxyphthalimide and its subsequent hydrazinolysis, while the esters of hydrazinomethylphosphonate were obtained for the first time in the course of this project *via* two methods. Di-Boc diazene reacts with methylphosphonate esters in strong basic conditions to form the Boc-protected hydrazinomethylphosphonate esters; there is also an option to synthesize hydrazinomethylphosphonates by the Kabachnik-Fields-type reaction with the Fmoc-protected hydrazone. It was found that phosphonic acids (and their salts) promote griseofulvin hydrolysis into griseofulvinic acid.

The antifungal and antibacterial activity of the obtained hydrazones and oximes is being studied at the Gause Institute of New Antibiotics.



**Figure 1.** Synthesis of griseofulvin derivatives.

Acknowledgements. This work was supported by the Russian Science Foundation (project No 20-74-10121).

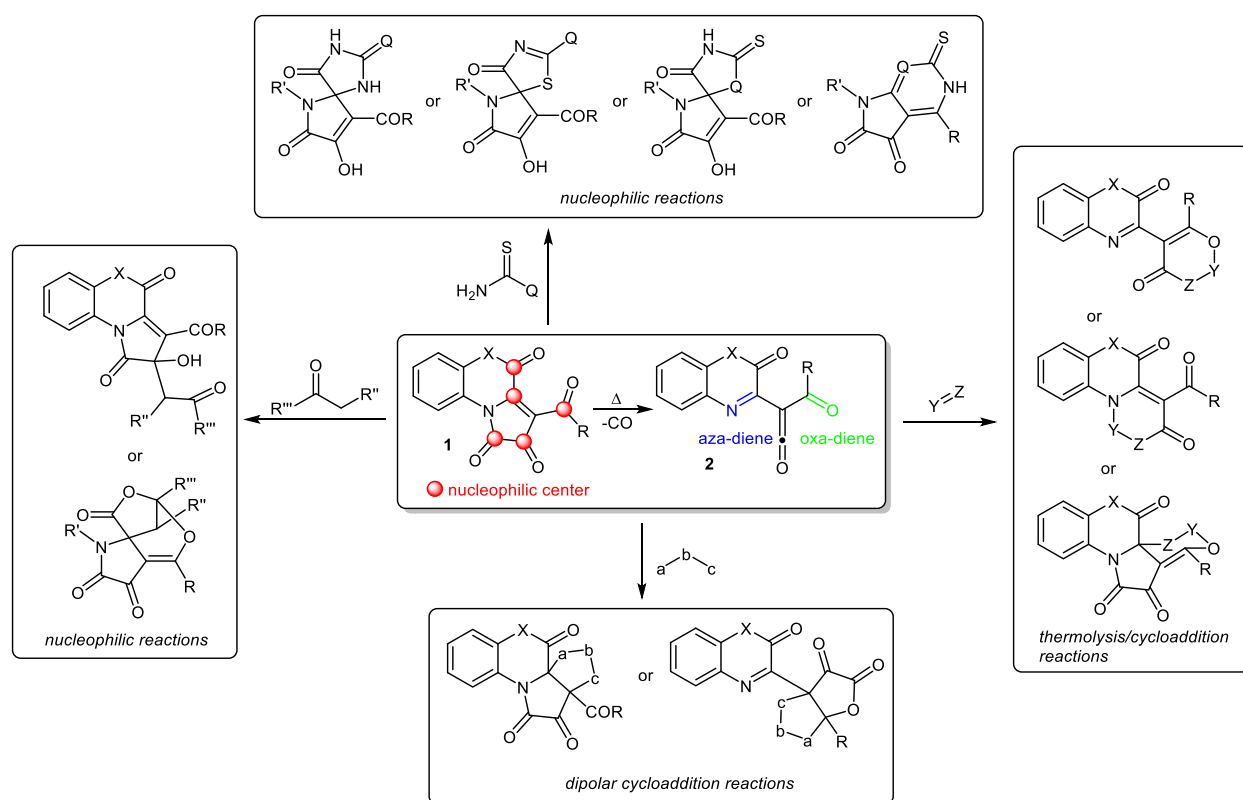
# DIVERSITY-ORIENTED SYNTHESSES VIA REACTIONS OF [e]-FUSED 1H-PYRROLE-2,3-DIONES

*Khramtsova E.E., Maslivets A.N.*

Perm State University, Perm, Russia  
Associate professor  
[caterina.stepanova@yandex.ru](mailto:caterina.stepanova@yandex.ru)

Diversity-oriented synthesis has become an intensifying trend in small molecule drug discovery [1, 2]. This approach allows to investigate wider chemical space creating diverse compounds collections from a limited set of reagents. Implementation of this methodology requires search for available polyfunctional reagents and investigation of their scope in diversity-oriented synthesis.

1*H*-Pyrrole-2,3-diones fused at [e]-side **1** (Figure 1) are polyelectrophilic synthetic platforms suitable for diversity-oriented synthesis (Figure 1). Their synthetic potential can be readily expanded by the generation bidentate dienes, acyl(imidoyl)ketenes **2**, from them (Figure 1). Various nucleophilic, dipolar, and thermolytic transformations of 1*H*-pyrrole-2,3-diones **1** and their derivatives **2** enable facile preparation of libraries of heterocyclic molecules with an emphasis on skeletal diversity from a single set of reagents (Figure 1).



**Figure 1.** Diversity-oriented syntheses based on transformations of 1*H*-pyrrole-2,3-diones fused at [e]-side **1**.

The libraries of skeletally diverse heterocycles derived from 1*H*-pyrrole-2,3-diones fused at [e]-side **1** (Figure 1) were found to exhibit significant antimicrobial, antifungal, analgesic, antiviral, and antihypoxic activities.

## References

- [1] Galloway W. R. J. D., Isidro-Llobet A., Spring D. R. *Nat. Commun.* **2010**, *1*, 80  
[2] Garcia-Castro M., Zimmermann S., Sankar M. G., Kumar K. *Angew. Chem. Int. Ed.* **2016**, *55*, 7586–7605

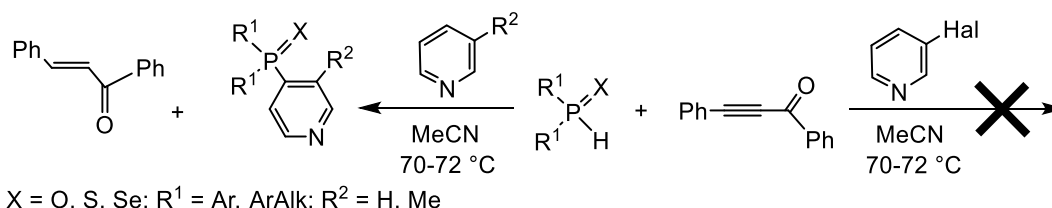
Acknowledgements. This work was supported by the Ministry of Science and Higher Education of the Russian Federation (FSNF-2020-0008) and the government of Perm Krai.

INFLUENCE OF THE SUBSTITUENT NATURE IN PYRIDINE ON THE RESULT OF OXIDATIVE CROSS-COUPLING OF PH-NUCLEOPHILES WITH AZINES

*Khrapova K.O., Telezhkin A.A., Volkov P.A.*

A.E. Favorsky Irkutsk Institute of Chemistry, Siberian Branch of the Russian Academy of Sciences,  
Irkutsk, Russia  
Young scientist  
[khrapova@irioch.irk.ru](mailto:khrapova@irioch.irk.ru)

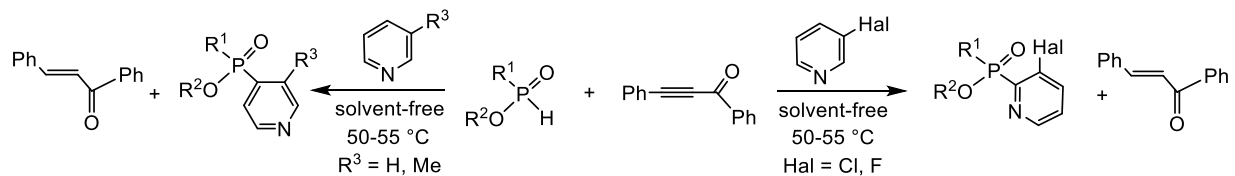
Recently, we have developed an original reaction of oxidative cross-coupling between secondary phosphine chalcogenides and pyridines with the participation of electron-deficient acetylenes as combined reagents-initiators (triggers). The main products of this reaction were 4-chalcogenophosphorylpyridines [1] (Figure 1). Acylphenylacetylenes were used as electron-deficient acetylenes. The latter are reduced in the course of the reaction to the corresponding alkenes of the *E*-configuration. The process has wide substrate scope both for various secondary phosphine chalcogenides and for various pyridines. It should be noted that, in the case of halogen-containing pyridines, the formation of phosphorylated pyridines was not observed.



**Figure 1.** Oxidative cross-coupling of phosphine chalcogenides with pyridines.

To expand the new methodology of nucleophilic substitution of a hydrogen atom in a heteroaromatic ring, new representatives of P-centered nucleophiles, in particular, R<sup>1</sup>R<sup>2</sup>OP(O)H, have been introduced into this reaction. It turned out that this type of PH-nucleophiles successfully reacted with pyridines in the presence of acylphenylacetylene under mild conditions (50–55 °C) without solvent to form strictly chemoselectively corresponding phosphorylated pyridines (Figure 2).

When using pyridines with electron-withdrawing groups (halogen atoms), the reaction unexpectedly leads to regioselective formation of 2-phosphorylpyridines. Although for unsubstituted pyridine, as well as pyridines containing donor groups, the target cross-coupling is realized with the formation of 4-phosphorylpyridines.



**Figure 2.** Reaction of pyridines with a new type of PH-nucleophiles, R<sup>1</sup>R<sup>2</sup>OP(O)H.

Thus, in the course of systematic studies, a new approach to the targeted synthesis of a poorly studied class of highly demanded phosphorylated pyridines was developed. It was found that the regioselectivity of the process is influenced by the nature of the substituent in the pyridine ring. The synthesized phosphorylpyridines are promising ligands for the design of metal complexes, precursors of biologically active drugs, and building blocks for organoelement synthesis.

### References

[1] Trofimov B.A., Volkov P.A., Khrapova K.O., Telezhkin A.A., Ivanova N.I., Albanov A.I., Gusarova N.K., Chupakhin O.N. *Chem. Commun.* **2018**, 54, 3371–3374

Acknowledgements. This work was supported by the President of the Russian Federation (program for the support of young Russian scientists, project MK-5606.2021.1.3).

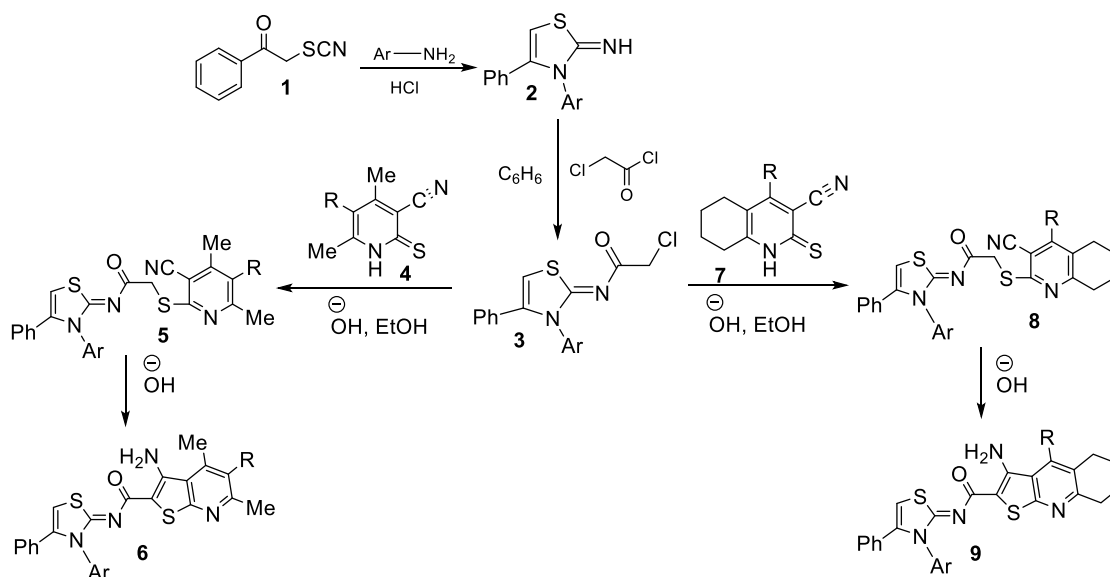
ON THE SYNTHESIS OF POLYHETEROCYCLIC ENSEMBLES DERIVED  
FROM ALPHA-THIOCYANATOKETONES

*Kindop V.K., Bepalov A.V., Dotsenko V.V.*

Kuban State University, Krasnodar, Russia  
Post-graduate Student  
[Slavakindop@mail.ru](mailto:Slavakindop@mail.ru)

Starting from alpha-thiocyanatocarbonyl compounds **1**, we succeeded to prepare 2-iminothiazolines **2** and chloroacetamides **3**. Chloroacetamides **3** are of interest as reagents for fine organic synthesis, as well as promising agrochemicals or their precursors. Further, compounds **3** were reacted in the presence of bases with a couple of 3-cyanopyridine-2(1H)-thionts (structures **4** and **7**). As a result, the new products of direct S-alkylation (pyridines **5** and **8**) were synthesized in high yields (85-96%).

When the reaction mixtures were treated with a second equivalent of base followed by warming, the Thorpe-Ziegler isomerization occurs to afford previously undescribed [1-2] polyheterocyclic ensembles bearing both thieno[2,3-b]pyridine and thiazoline core units (structures **6** and **9**). It seems likely that the presence of two bounded phramacophore fragments will lead to increase of the pharmacological properties. Moreover, the introducing of thienopyridine fragment allow greater variability for the structural modification, as well as the increase in the affinity to a wider range of biological protein receptors is also expected.



**Figure 1.** The preparation of thieno[2,3-b]pyridine/thiazoline hybrid polyheterocyclic ensembles starting from easily available alpha-thiocyanatocarbonyl compounds.

The structures of compounds **6** and **9** were confirmed by FTIR and NMR spectroscopy and X-ray diffraction analysis. The target compounds **6** and **9** appeared as bright yellow crystals and revealed enhanced fluorescence upon irradiation with 254 or 365 nm UV light.

#### References

- [1] Litvinov, V.P., Dotsenko, V.V., Krivokolysko, S.G. *Russian chemical bulletin.*, **2005**, 54 (4), 864–904.  
[2] Litvinov, V.P., Dotsenko, V.V., Krivokolysko, S.G. *Advances in heterocyclic chemistry*, **2007**, 93, 117–178.

Acknowledgements. The reported study was funded by Russian Foundation for Basic Research and Krasnodar region according to the research project № 19-43-230007.



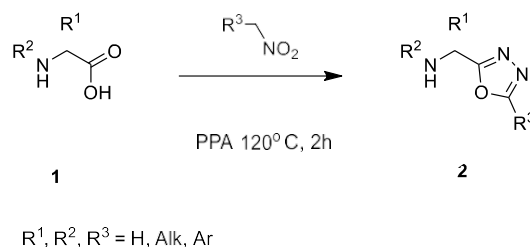
NEW SYNTHESIS 1,3,4-OXADIAZOLES OF AMINO ACID  
VIA ELECTROPHILIC ACTIVATION OF NITROALKANES

*Kirilov N.K.<sup>1</sup>, Aksenov A.V.<sup>1</sup>, Aksenov N.A.<sup>1</sup>, Arutyunov N.A.<sup>1</sup>*

<sup>1</sup>North-Caucasus Federal University, Stavropol, Russia PhD student  
[lycheron@gmail.com](mailto:lycheron@gmail.com)

Recently our research group has reported efficient synthesis of 1,3,4-oxadiazoles, containing different substituents in **2** and **5** positions via electrophilic activation of nitroalkanes in polyphosphoric acid and further cyclocondensation with acylhydrazides. [1]

We wondered about the possibility of expanding of employing of this reaction using various amino acids (**1**) on the way to 1,3,4-oxadiazoles with an amino group (**2**) in the alpha position (**Figure 1**). This reaction takes place at 120 ° C in good yields (50-80%).



**Figure 1.** Reaction.

Thus, as a result of the study, the reaction of alpha amino acid hydrazides in a PFC medium with activated nitroalkanes under mild conditions, including cyclocondensation, was discovered.

#### References

[1] Aksenov A. V., Khamraev V., Aksenov N. A. et al. *RSC advances* **2019**, 9 (12), 6636-6642

Acknowledgements. This work was supported by Russian Foundation for Basic Research № 20-33-90026.

# DESIGN AND SYNTHESIS PRODRUG FORMS OF DIHYDROFURANOALLOCOLCHICINOIDS

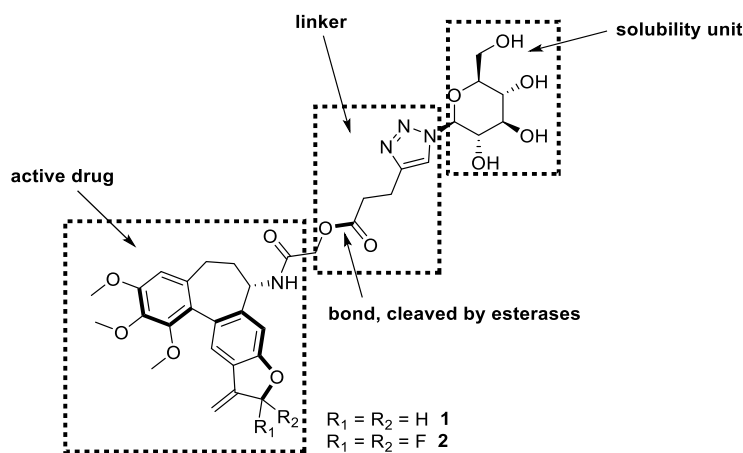
*Kobanova D.A.<sup>1</sup>, Schegravina E.S.<sup>1</sup>, Fedorov A.Yu.<sup>1</sup>*

<sup>1</sup>Lobachevsky State University, Nizhny Novgorod, Russia

Student

[d.a.kobanova@gmail.com](mailto:d.a.kobanova@gmail.com)

Herein we report a method of synthesis of sugar-containing water-soluble prodrugs of dihydrofuranoalcolchicinoids. Colchicine derivatives are known not only because of high anticancer activity, but also several disadvantages such as poor solubility in water, low selectivity of action against tumor cells comparing to the normal cells [1]. These problems stimulate further modification of colchicine. One of the strategies to increase of water-solubility and, consequently, bioavailability is the design of prodrugs. We proposed the compound, containing carbohydrate unit as water-soluble form. Ester-bond between colchicinoid and linker, which can be cleaved by non-special esterases is created by hydroxylated acetamide fragment.



**Figure 1.** The structure of proposed compound

Compound **1** demonstrates cytotoxicity in the sub-micromolar concentration (475-800 nM) range towards human colon carcinoma COLO and immortal keratinocytes HaCaT cell lines. Obtained conjugate can served as basis for development of anticancer target drugs. The structure of compound **1** was proven by spectra <sup>1</sup>H-NMR, <sup>13</sup>C-NMR.

The development of new prodrugs abovementioned anticancer agents is underway. Perspective approach is synthesis of phosphonate prodrugs by phosphorylation of hydroxylated colchicinoid with dibenzyl phosphite.

## References

[1] A.A. Ghawanmeh. Eur. J. Med. Chem. **2018**, 144, 229-242.

Acknowledgements. This work was supported by the Russian Science Foundation (Project № 19-13-00158).

Kolchina G. Yu.

<sup>1</sup>Sterlitamak branch of the Bashkir State University, Sterlitamak, Russia  
Cand. Sci. (Tech.), Associate Prof.  
[kolchina.gyu@mail.ru](mailto:kolchina.gyu@mail.ru)

Lubricating oils play an important role in the performance of friction units in various machines, engines and mechanisms, regardless of their purpose. Fundamental and applied research related to the petrochemistry of lubricating oils and cutting fluids has led to the rapid development of work on the creation, improvement and use of additives in them - heteroorganic compounds of various functional purposes, which have a significant effect through a certain mechanism on the physicochemical and operational properties. petroleum product. Due to the fact that it is impossible to achieve those performance properties that are required by modern mechanisms and equipment, using only high-quality base oils, they are supplemented with special additives.

To solve urgent problems related to the structure of heteroorganic systems, it is necessary to attract and develop new scientific approaches based on the use of computer methods and discrete mathematics, such as methods of molecular mechanics and molecular dynamics, methods of linear algebra, graph theory, as well as methods of nonlinear dynamics that are able to solve problems of a fundamental and applied nature in petrochemistry, which is today a rather promising direction. Worldwide experience in the study of complex molecules and systems shows the successful application of computational chemistry to describe the relationship between the structure of a molecule and its practical properties.

According to the results of studying the properties of disulfides [1-2] in lubricating oil M-8 and Azerole-5, it follows that the antimicrobial properties of compounds with Alk- and Ph-fragments correspond, and in some cases exceed the level of antimicrobial activity of the known biocidal additive - pentachlorof Sodium nolate, widely used for the biostabilization of petroleum products. Disulfides have both bactericidal and fungicidal properties and can be recommended as effective biocidal additives to lubricants.

Along with the well-known synthesized compounds, a new Grotan-OX has been developed. When combined with allyl pentyl disulfide in ratios of 1:1 and 1:3, results in improved biocidal and fungicidal properties, allowing fewer materials to be used for acceptable performance, reducing material consumption. In the presence in the composition of the reagent "Grotan-OX" individually or in combination with synthesized organic allylpentyl disulfide at low concentrations (0.5%) significantly increases its oil-displacing property (87%) and at the same time provides effective biocidal and inhibitory properties.

Thus, the study of the reactivity of additives using the methods of computational chemistry, their chemical and physicochemical properties, the development of new multifunctional additives and the possibilities of their practical application are tasks that correspond to the current trends in the development of science. Their solution will make it possible to create a strong theoretical basis for the work of the petrochemical direction with the aim of more efficient use of additives to lubricating oils [3-4].

## References

- [1] Babayev E.R., Farzaliev V.M., Mamedova P.Sh., Streek M., Poletaeva O.Yu., Kolchina G.Yu., Movsumzade E.M. *DGMK Tagungsbericht* **2018**, 161-166.
- [2] Farzaliev V.M., Babaev E.R., Alieva K.I., Poletaeva O.Yu., Movsumzade E.M., Kolchina G.Yu. *Transportation and storage of petroleum products and hydrocarbon raw materials* **2016**, 3, 24-28.
- [3] Kolchina G.Yu., Poletaeva O.Yu., Movsumzade E.M., Babaev E.R., Bakhtina A.Yu., Mamedova P.Sh. *Bashkir Chemical Journal* **2020**, 27, 1, 28-32.
- [4] Tukhvatullin R.F., Kolchina G.Y., Movsumzade E.M., Mamedova P.S., Babaev E.R. *ChemChemTech* **2018**, 61, 4-5, 84-92.

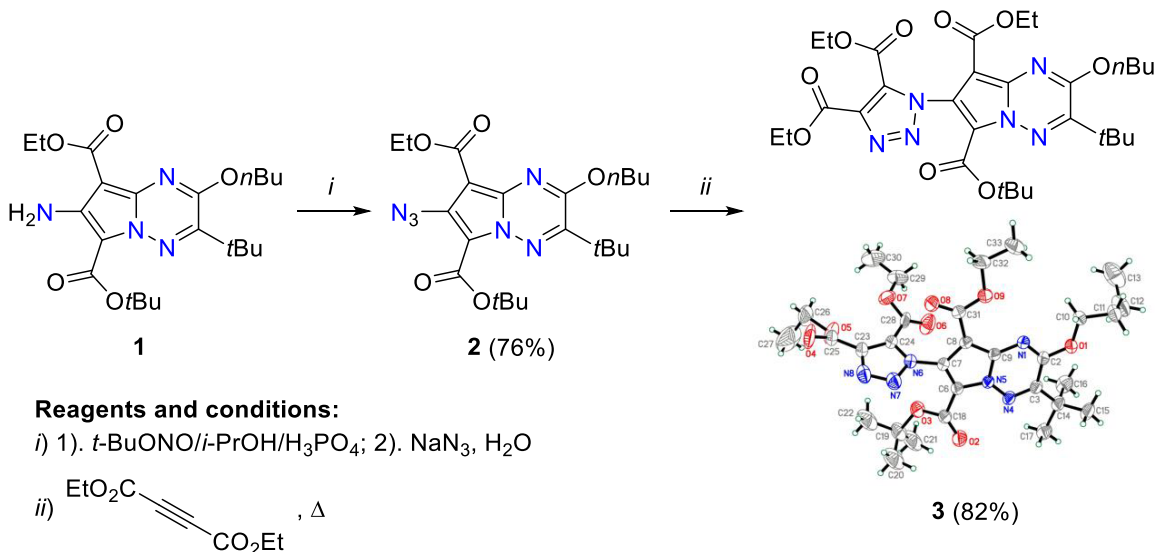
SYNTHESIS AND CRYSTAL STRUCTURE OF THE STERICALLY HINDERED  
 PYRROLO[1,2-*b*][1,2,4]TRIAZINE-6,8-DICARBOXYLATE

*Koltun D.S.*<sup>1</sup>, *Ivanov S.M.*<sup>1</sup>

<sup>1</sup>N.D. Zelinsky Institute of Organic Chemistry Russian Academy of Sciences, Russia  
 Student

[deniscoltun@yandex.ru](mailto:deniscoltun@yandex.ru)

1,2,4-Triazines [1] constitute an important class of six-membered heterocycles which have found broad use as effective antiviral agents [2-3], e.g. pyrrolo[2,1-*f*][1,2,4]triazine (Remdesivir) [3]. In continuation of our studies on the chemical and structural properties of functionalized azolo[1,2,4]triazines [4-5], we have successfully prepared sterically hindered compound **3** and studied it by X-ray diffraction.



**Figure 1.** Synthesis and cycloaddition of 7-azidopyrrolo[1,2-*b*][1,2,4]triazine-6,8-dicarboxylate **2**.

Compound **1** was diazotized using *t*-BuONO/*i*-PrOH mixture in the presence of H<sub>3</sub>PO<sub>4</sub>, followed by the addition of NaN<sub>3</sub>. Thermal [3+2] cycloaddition reaction of the formed azide **2** with diethyl acetylenedicarboxylate furnished novel 7-triazolyl-pyrrolo[1,2-*b*][1,2,4]triazine-6,8-dicarboxylate **3**. The X-ray diffraction analysis showed a practically orthogonal orientation of the triazole group towards the plane of the bicyclic system.

### References

- [1] Voinkov E.K., Drokin R.A., Ulomskii E.N., Chupakhin O.N., Charushin V.N., Rusinov V.L. *Chem. Heterocycl. Compd.* **2020**, *56*, 1254–1273.  
 [2] Rusinov V.L., Ulomskii E.N., Chupakhin O.N., Charushin V.N. *Russ. Chem. Bull. Int. Ed.* **2008**, *57*, 985–1014.  
 [3] Knapp R.R., Tona V., Okada T., Sarpong R., Garg N.K. *Org. Lett.* **2020**, *22*, 8430–8435.  
 [4] Ivanov S.M., Koltun D.S. *Struct. Chem.* **2021**, published online, DOI: 10.1007/s11224-021-01768-0.  
 [5] Ivanov S.M. *J. Heterocycl. Chem.* **2021**, published online, DOI: 10.1002/jhet.4255.

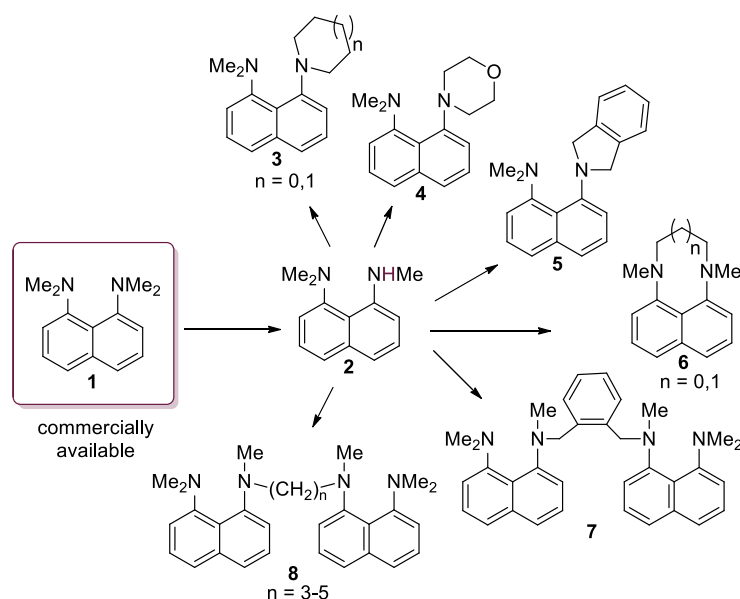
# DIHALOGENOALKANES AS REAGENTS FOR MODIFICATION OF DIALKYLAMINO GROUPS IN NAPHTHALENE PROTON SPONGES

*Kolupaeva E.V., Ozeryanskii V.A.*

Southern Federal University, Rostov-on-Don, Russia  
PhD Student  
[kolupaeva.ev@gmail.com](mailto:kolupaeva.ev@gmail.com)

Since the discovery of unusual physicochemical properties of 1,8-bis(dimethylamino)naphthalene (**1**) («proton sponge») and its anomalously high basicity, the study of proton sponges, both experimental and theoretical, has grown enormously [1]. To understand the reasons behind these unusual properties, modified analogs were required. Previously, this type of compounds was synthesized either from 1,8-diamino- or 1,8-bis(methylamino)naphthalenes [2]. At the same time, commercially available diamine **1** was never considered as the starting material to synthesize symmetrical and asymmetrical derivatives. Thus, one of the current directions in the development of proton sponges' chemistry is the modification of dialkylamino groups in the parent compound, for example, by formation of heterocycles or *N*-linked dimers.

Utilization of different dihalogenoalkanes as bielelectrophiles is one of the simplest ways to form heterocyclic amino groups. So, our approach is based on the reactions of 1-dimethylamino-8-methylaminonaphthalene (**2**), easily obtained from proton sponge **1** [3], with different dihalides (Scheme 1) [4]. The process of heterocyclization was accompanied by demethylation of the starting compound. The result of heterocyclization depended on the length of the carbon chain. Thus, heterocyclization proceeded onto the same nitrogen atom in cases of 1,4-dibromobutane, 1,5-dibromopentane, bis(2-chloroethyl) ether and *o*-xylylene dibromide (**3–5**). The use of shorter linker led to symmetrical heterocycles **6**.



**Scheme 1.** New routes of proton sponge modification.

Notably, the reaction conditions are critical for the outcome. In many cases, the conduction of the reaction without auxiliary base led to previously unknown double proton sponges connected through nitrogen atoms **7-8**.

Some other unusual transformations leading to derivatives of 1,8-bis(dimethylamino)naphthalene using organic dihalides as electrophiles, including direct one-pot transformations, will be also reported.

## References

- [1] Pozharskii A.F., Ozeryanskii V.A. *The Chemistry of Anilines*, ed. Z. Rappoport, Wiley **2007**, pp. 931–1026
- [2] Alder R.W., Bryce M.R., Goode N.C., Miller N., Owen J. *J. Chem. Soc., Perkin Trans. 1* **1981**, 2840–2847
- [3] Ozeryanskii V.A., Pozharskii A.F., Koroleva M.G., Shevchuk D.A., Kazheva O.N., Chekhlov A.N., Shilov G.V., Dyachenko O.A. *Tetrahedron* **2005**, *61*, 4221–4232
- [4] Kolupaeva E.V., Ozeryanskii V.A., Pozharskii A.F. *Synthesis* **2020**, *52*, 3427–3438

INTERACTION OF PERFLUOROBENZOCYCLOBUTENE WITH ISOMERIC TETRAFLUOROBENZENES  
IN SbF<sub>5</sub> MEDIUM

*Komarov V.V.*<sup>1,2</sup>, *Mezhenkova T.V.*<sup>2</sup>

<sup>1</sup>Novosibirsk State University, Novosibirsk, Russia

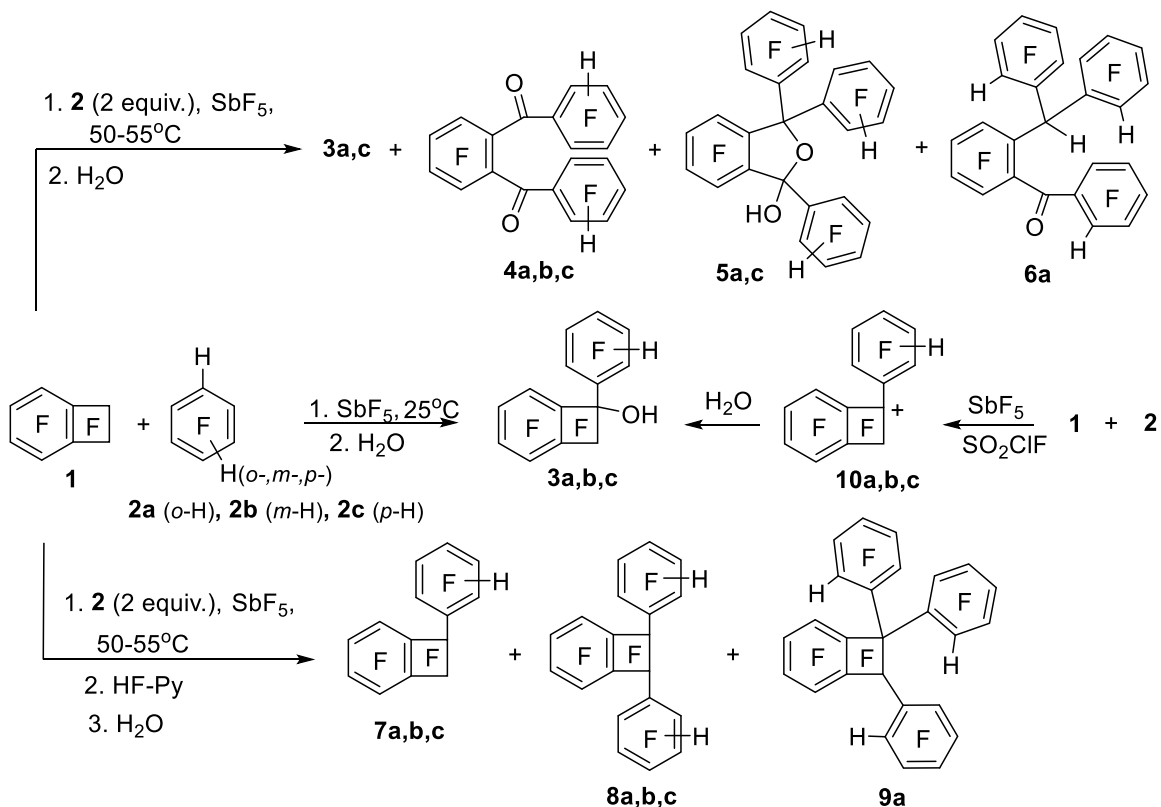
<sup>2</sup>N.N. Vorozhtsov Novosibirsk Institute of Organic Chemistry SB RAS, Novosibirsk, Russia

Student

vkomarov@nioch.nsc.ru

In a recent study there has been shown that interaction of perfluorobenzocyclobutene (**1**) with an excess of pentafluorobenzene in SbF<sub>5</sub> medium followed by hydrolysis leads to formation of perfluoro-1,3,3-triphenyl-1,3-dihydro-2-benzofuran-1-ol along with perfluoro-1,2-dibenzoylbenzene [1]. In order to investigate the behaviour of benzocyclobutene **1** with other polyfluorobenzenes the interaction of benzocyclobutene **1** with isomeric 1,2,3,4-, 1,2,3,5-, 1,2,5,6-tetrafluorobenzenes (**2a,b,c**) has been studied.

Interaction of benzocyclobutene **1** with the equimolar amount of tetrafluorobenzenes **2a,b,c** in SbF<sub>5</sub> medium with further treatment of the reaction mixture with water leads to corresponding 1-(tetrafluorophenyl)benzocyclobutene-1-ols **3a,b,c**. Heating of benzocyclobutene **1** with two equivalents of tetrafluorobenzenes **2a,b,c** in SbF<sub>5</sub> medium at 50-55 °C with subsequent hydrolysis of the reaction mixture gives corresponding diketones **4a,b,c** and compounds **5a,c**, **6a**. When the reaction mixture was treated with HF-Py corresponding 1-(tetrafluorophenyl)benzocyclobutenes **7a,b,c** and 1,2-bis(tetrafluorophenyl)benzocyclobutenes **8a,b,c** were obtained. In the case of *ortho*-isomer **2a** 1,1,2-tris(tetrafluorophenyl)benzocyclobutene **9a** was also obtained. It has been shown that 1-(tetrafluorophenyl)benzocyclobuten-1-yl cations **10a,b,c** can be generated in the reaction of benzocyclobutene **1** with tetrafluorobenzenes **2a,b,c** in SbF<sub>5</sub> medium. Treatment of the solutions of the salts of cations **10a,b,c** with water leads to the formation of compounds **3a,b,c** (fig.1).



**Figure 1.** Reaction of perfluorobenzocyclobutene with isomeric tetrafluorobenzenes.

Routes of the reactions will be discussed.

**References**

[1] Mezhenkova T.V., Sinyakov V.R. et al. *Russ. J. Org. Chem.* **2018**, 54, 545-553

DIETHANOLAMMONIUM GOOD'S BUFFER IONIC LIQUIDS FOR THE SYNTHESIS  
OF <sup>68</sup>GA-LABELLED RADIOPHARMACEUTICALS

*Kondratenko Yu.A.*<sup>1</sup>, *Antuganov D.O.*<sup>2</sup>, *Zolotarev A.A.*<sup>3</sup>, *Nadporojskii M.A.*<sup>2</sup>, *Kochina T.A.*<sup>1</sup>

<sup>1</sup>Grebenshchikov Institute of Silicate Chemistry RAS, Saint Petersburg, Russia

<sup>2</sup>Granov Russian Research Center of Radiology & Surgical Technologies, Saint Petersburg, Russia

<sup>3</sup>Saint Petersburg State University, Saint Petersburg, Russia

Young Scientist

[kondratenko.iulia@yandex.ru](mailto:kondratenko.iulia@yandex.ru)

Ionic liquids (ILs) are a great class of compounds consisting of bulky organic cations and protic acid anions with melting points below the boiling point of water. Recently, ILs, possessing self-buffering capacity, have been assigned to a separate class - Good's buffer ILs (GB-ILs). Typically, these ILs contain Good's buffers (GBs) as cations or anions. One of the priorities is the usage of GB-ILs as buffer agents in radiopharmaceuticals, in particular, for the synthesis of <sup>68</sup>Ga-labeled compounds. The gallium-68 isotope is one of the most important and valuable in PET diagnostics due to its optimal decay properties and simple binding to chelating groups of bioactive molecules [1]. At the same time, as a rule, the formation of a Ga-chelator bond is possible only in a narrow pH range (3.5-4.5). Therefore, it is necessary to use buffers to maintain the desired pH.

Our previous works [2-4] showed that alkanolammonium protic ILs, in particular TEA, TRIS (tris(hydroxymethyl)methyl ammonium), PDA (N-phenyldiethanolammonium), and TPA (tris(2-hydroxypropyl)ammonium) salts, are effective buffer agents in <sup>68</sup>Ga-radiolabeling reactions of chelators and clinically approved peptides. Diethanolamine (DEA) and its N-derivatives are promising alkanolamines for the production of alkanolammonium GB-ILs. This study aimed to obtain and characterize new protic ILs containing diethanolammonium cations and carboxylic acid anions.

Fifteen new protic ionic liquids based on DEA salts of carboxylic acids have been synthesized and identified using a complex of physicochemical methods (NMR, FT-IR spectroscopy, elemental, thermal analysis). It was found that all synthesized DEA salts isolated in both solid and liquid form are protic ILs. The crystal structure of diethanolammonium salts of benzoic and 2-hydroxy-1-naphthoic acids was determined for the first time by XRD. Crystal structure analysis of DEA salts showed that the presence of two hydrogen atoms in the ammonium group leads to the possible formation of two conformations for DEA cations that differ in the orientation of the hydroxyethyl groups relative to the ammonium hydrogen atoms. The difference in the structure of DEA cations significantly affects the intermolecular hydrogen bonding.

The effectiveness of synthesized DEA ionic liquids as buffer agents was demonstrated on <sup>68</sup>Ga-radiolabeling reactions with different chelators and clinically approved peptides. We confirmed that the DEA benzoate is a promising buffer agent in <sup>68</sup>Ga-radiolabeling reactions with cyclic and acyclic bifunctional chelating agents. Preparation of <sup>68</sup>Ga-labelled clinically relevant peptides (NOTA-AMBA, DOTA-AMBA, NOTA-JR11, DOTA-JR11, DOTA-NOC, DOTA-TATE, PSMA-617) in "low-temperature" conditions demonstrates the performance of DEA benzoate over HEPES buffer in radiolabeling reactions. The potential of diethanolammonium ionic liquids in the clinical production of radiopharmaceuticals well worth investigating in the future.

### References

- [1] Velilyan I. *Molecules* **2015**, *20*, 12913-12943
- [2] Fundamensky V.S., Kochina T.A., Kondratenko Y.A., Zolotarev A.A., Vlasov Yu.G., Ignatyev I.S. *J. Mol. Liq.* **2017**, *230*, 113–120.
- [3] Kondratenko Yu.A., Nikonorova A.A., Zolotarev A.A., Ugolkov V.L., Kochina T.A. *J. Mol. Struct.* **2020**, *1207*, 127813.
- [4] Kondratenko Y.A., Antuganov D.O., Kadnikova O.Yu., Zolotarev A.A., Ugolkov V.L., Nadporojskii M.A., Kochina T.A. *J. Mol. Liq.* **2021**, *324*, 114717.

Acknowledgements. This work was supported by the Russian Science Foundation (research project No. 20-73-00033).

# TRANSFORMATION OF THE NITROSYL IRON COMPLEXES WITH THIOUREA DERIVATIVES IN AQUEOUS SOLUTIONS WITH SERUM BOVINE ALBUMIN

*Kormukhina A.Yu.*<sup>1,2</sup>, *Pokidova O.V.*<sup>2</sup>, *Sanina N.A.*<sup>1,2,3</sup>

<sup>1</sup>Moscow State University, Moscow, Russia

<sup>2</sup>Institute of Problems of Chemical Physics of the RAS, Chernogolovka, Russia

<sup>3</sup>Moscow Region State University, Mytishchi, Russia

Student

[alex.kormukhina2015@yandex.ru](mailto:alex.kormukhina2015@yandex.ru)

At the end of the last century, a group of scientists showed that nitric oxide (NO) is an important component of the cardiovascular system and promotes vasodilation. However, exogenous donors NO used in clinical practice have some disadvantages. Therefore, an urgent task of modern science is to develop compounds that can effectively generate nitric oxide *in vivo*.

The development of synthetic analogs of natural NO pools, nitrosyl iron complexes (NICs), is carried out at the Institute of Problems of Chemical Physics of the Russian Academy of Sciences. This study considers the mononuclear cationic nitrosyl iron complex with N, N'-dimethylthiourea ligands  $[\text{Fe}(\text{SC}(\text{NHCH}_3)_2)_2(\text{NO})_2]\text{BF}_4$  (complex **1**) [1], also hybrid complex  $[\text{Fe}(\text{SC}(\text{NH}_2)_2)_2(\text{NO})_2]_2[\text{Fe}_2(\text{S}_2\text{O}_3)_2(\text{NO})_4]$  (complex **2**) [2]. Complex **1** has a high cytotoxic activity to multiple myeloma cells [3]. Complex **2** is an effective cytoprotector that protects cells from the toxic effects of doxorubicin [4]. The study of the transformation of the complexes will help to assess the possibility of their application as drugs in the future.

It is known that one of the main targets of NICs *in vivo* is the transport protein of blood albumin [5]. Therefore, this study looks at a comparison of the effect of bovine serum albumin (BSA) on the decay of complex **1** and complex **2** *in vitro*.

We have studied the decay of complexes under aerobic conditions, also their decomposition with bovine serum albumin (BSA) using the spectrophotometry method. In the absorption spectra of complex **1** and complex **2** in the Tris-HCl buffer we observe an increase in the optical density at 280-370 nm, which indicates a rapid reaction of the complexes with oxygen.

However, we obtained other forms of absorption spectra in the presence of a protein. In this case, we registered a shoulder at 370-410 nm, the intensity of which decreases with time. We assume that the appearance of this shoulder indicates the formation of a protein-bound complex as a result of coordination of  $\text{Fe}(\text{NO})_2^+$  fragment with the free SH-group of Cys34 and the imidazole nitrogen of His39.

We analyzed the binding of the complexes to BSA using the method of fluorescence spectroscopy. In our case, fluorescence quenching is observed by about 50%, accompanied by a shift in the fluorescence spectrum, which indicates a partial quenching of the fluorescence of tryptophan residues. To quantify this quenching of BSA fluorescence, a modified Stern–Volmer equation is used and the Stern–Volmer constant was determined:  $K=2.3 \cdot 10^5 \text{ M}^{-1}$  for complex **1** and  $7.2 \cdot 10^5 \text{ M}^{-1}$  for complex **2**. Also, to analyze the effect of protein-bound complexes formation on the quenching efficiency of each tryptophan residue, the Förster radius was calculated, which is the distance when fluorescence quenching is carried out by 50%.

Thus, a comparative analysis of the decomposition of both complexes showed that albumin can actively participate in the biotransformation of NICs.

## References

- [1] Shmatko N.Yu., Korchagin D.V. *Polyhedron* **2017**, 137, 72–80
- [2] Sanina N.A., Aldoshin S.M. *New Journal of Chemistry* **2015**, 39, 1022–1030
- [3] Akentieva N.P., Sanina N.A. *Proceedings of the Academy of Sciences* **2019**, 486, 742–747
- [4] Gizatullin A.R., Akentieva N.P. *Doklady Biochemistry and Biophysics* **2018**, 483, 337–340
- [5] Shumaev K.B., Kosmachevskaya O.V. *Methods in Enzymology* **2008**, 436, 445–461

Acknowledgements. This work was supported by president grant (No MK-1634.2021.1.3.).



# NEW HYBRID MATERIALS BASED ON NANOSTRUCTURED ALUMINUM OXYHYDROXIDE AND ANCHORED PORPHYRINS

*Korobkov S.M.*<sup>1,2</sup>, *Birin K.P.*<sup>2</sup>, *Khodan A.N.*<sup>2</sup>, *Gorbunova Yu.G.*<sup>2,3</sup>, *Tsivadze A.Yu.*<sup>2,3</sup>

<sup>1</sup>Lomonosov Moscow State University, Moscow, Russia

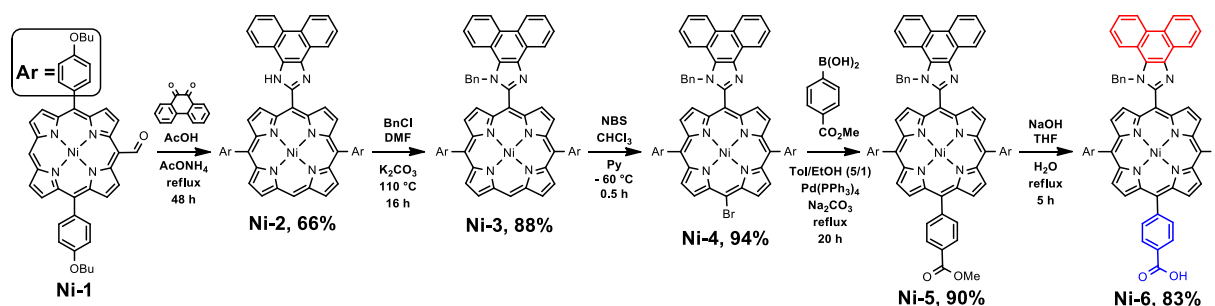
<sup>2</sup>A.N.Frumkin Institute of Physical Chemistry and Electrochemistry RAS, Moscow, Russia

<sup>3</sup>N.S. Kurnakov Institute of General and Inorganic Chemistry RAS, Moscow, Russia

Student

skor42@inbox.ru

The development of approaches towards new types of photoactive porphyrins is an actual field of the research. A challenging objective is to create a porphyrin-based hybrid material with catalytic properties. Nanostructured alumina oxyhydroxide (NAO) modified with a SiO<sub>2</sub> layer (NAOM) could be used as an inorganic component of the hybrid material. NAO is a highly porous material with fibril structure, which can be obtained by slow oxidation of an amalgam layer on the surface of aluminum plate. Its chemical formula can be written as Al<sub>2</sub>O<sub>3</sub>·nH<sub>2</sub>O, where n~3.6 [1]. Only one example of the immobilization of a tetrapyrrolic compound on the surface of NAOM is reported to the moment [2]. This work demonstrates a synthetic pathway for the preparation of non-symmetric porphyrins involving Radziszewski condensation (**Ni-2**) and subsequent C-C cross-coupling reaction using **Ni-4** (**Scheme 5**). The obtained porphyrin (**Ni-6**) contains anchoring group for further immobilization on the surface of NAOM as well as a polyaromatic fragment bridged *via* an imidazole moiety.



**Scheme 5.** Synthesis of the target bifunctional porphyrin.

It was found that direct bromination of **Ni-2** provided a mixture of compounds with relatively low yield, while the bromination of the benzyl-protected porphyrin (**Ni-3**) provided the target product in high yield. Moreover, the proton exchange process between the nitrogen atoms of the imidazole leads to significant broadening of signals in the NMR spectra, thus complicating their analysis. Benzilation of NH-fragment allows to avoid the exchange process so the spectra become interpretable.

An unexpected broadening of signals of the protons of *meso*-aryl groups in NMR spectra was found for all benzylated compounds. Most likely, the complexity of the obtained porphyrins results in a variety of dynamic processes. This phenomenon was studied by means of variable-temperature NMR. The decrease of temperature to 223K allowed the observation of all expected signals with fine resolution. Surprisingly, the complete inequivalence of all protons of *meso*-aryl groups was observed in **Ni-4 – Ni-6** NMR spectra.

Finally, complex **Ni-6** was immobilized on the surface of NAOM by treatment of the inorganic material with a DCM solution of the porphyrin. The grafting ratio of the obtained material was found to be 1 mg of porphyrin per 8 mg of NAOM. The quantitative evaluation was performed by the analysis of the residues after the immobilization by means of UV-vis spectroscopy. In turn, the obtained hybrid material was characterized by means of XPS, IR and UV-vis spectroscopy. The obtained stable hybrid material can be used in further research as a model of prospective photoactive materials.

Acknowledgements. The authors are grateful to the Ministry of Science and Higher Education of the Russian Federation for financial support.

## References

- [1] Khodan A. et al. *J. Nanoparticle Res. Journal of Nanoparticle Research* **2018** 20 (7).
- [2] Martynov A.G. et al. *Prot. Met. Phys. Chem. Surfaces* **2018** 54 (2) 185–191.

## BIOLOGICALLY ACTIVE COMPLEXES OF COPPER(II) WITH 2-FUROIC ACID

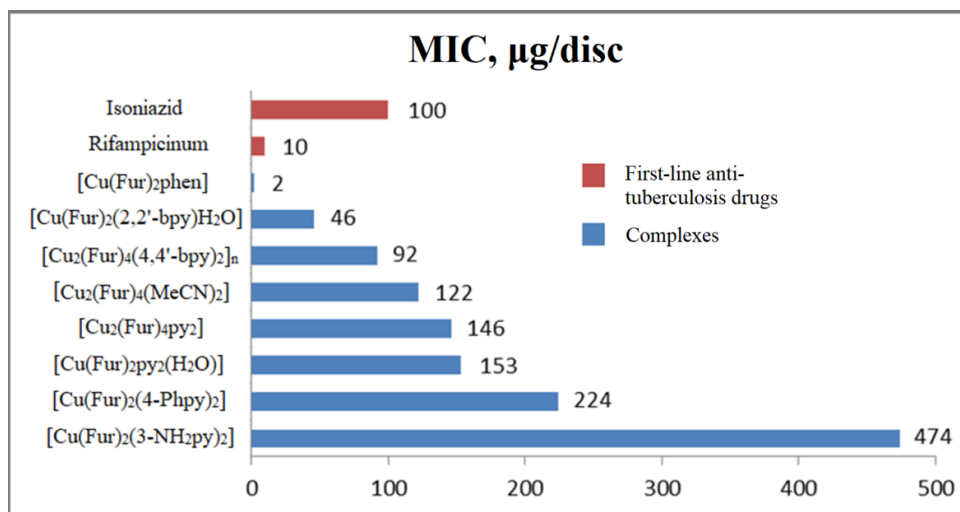
*Koshenskova K.A.*<sup>1</sup>, *Lutsenko I.A.*<sup>2</sup>, *Kiskin M.A.*<sup>2</sup>, *Becker O.B.*<sup>3</sup>, *Eremenko I.L.*<sup>2</sup>

<sup>1</sup>*D. Mendeleev University of Chemical Technology of Russia, Moscow, Russia*  
<sup>2</sup>*N.S. Kurnakov Institute of General and Inorganic Chemistry RAS, Moscow, Russia*  
<sup>3</sup>*Vavilov Institute of General Genetics RAS, Moscow, Russia*  
*ksenia-18.11.99@mail.ru*

The problem of tuberculosis remains the second after HIV among infectious diseases, and all the ways of creating effective means of combating *Mycobacterium tuberculosis* (MBT, Koch's bacillus) are blocked due to its phenotypic heterogeneity, increased adaptive ability, as well as the presence of a system of natural drug resistance genes, which provides the pathogen with an abnormally high survival rate in adverse conditions. Recently, work has been actively carried out on the study of the biological activity of coordination compounds of metals in relation to various pathogens - fungal and bacterial infections, malaria, tuberculosis, as well as cancer cells.

In this work, 2-furoic acid (pyromucic acid, HFur) and copper(II) complexes with N-donor ligands (pyridine (py), 2,2'- and 4,4'-bipyridine (bpy), 1,10-phenanthroline (phen), 4-phenylpyridine (phpy), 3-aminopyridine (NH<sub>2</sub>-py)). The purpose of this study was to develop methods for producing Cu(II) complexes and to determine the biological activity *in vitro* against a non-pathogenic strain of *Mycolicibacterium smegmatis*.

A number of mono- and binuclear complexes were obtained with the composition [Cu<sub>2</sub>(Fur)<sub>4</sub>(L)<sub>x</sub>] (L = H<sub>2</sub>O (1), CH<sub>3</sub>CN (2); x = 1, 2); [Cu(Fur)<sub>2</sub>L(H<sub>2</sub>O)] and [Cu<sub>2</sub>(Fur)<sub>4</sub>L<sub>2</sub>] (L = py (3), bpy (4), phen (5), phpy (6), NH<sub>2</sub>-py (7)). All compounds were isolated as single crystals and their structure was determined by X-ray diffraction. For copper(II) complexes with pyridine, it was found that they are formed from one reaction mixture sequentially, first binuclear, then mononuclear (the formation of the second reaction product occurs due to an increase in the concentration of pyridine relative to copper(II) ions as of the binuclear complex into the sediment).



**Fig.1** – Antibacterial activity *in vitro* against a non-pathogenic strain *M. Smegmatis*

Analysis of the obtained structural data and the results of *in vitro* biological activity against *Mycolicibacterium smegmatis* for 8 complexes showed a certain correlation between the presence of various co-ligands in the complexes and the manifestation of bioactivity. Thus, the phen ligand in [Cu(fur)<sub>2</sub>(1,10-phen)] causes high bioactivity (the minimum inhibitory concentration (MIC) was 2 µg/disc), which is several times higher than the activity of rifampicin (MIC = 10 µg/disc) and isoniazid (MIC = 100 µg/disc) - first-line drugs for treatment of tuberculosis. On the contrary, py, phpy and NH<sub>2</sub>-py practically completely inactivates the biological activity of the complexes 3, 6 and 7 (Fig. 1).

Acknowledgements. The work was supported by the Russian Science Foundation (project 20-13-00061).

# NEW ANALOGS OF TRYPTANTHRIN-6-OXIME AS PERSPECTIVE JNK INHIBITORS

*Kovrizhina A.R.<sup>1</sup>, Khlebnikov A.I.<sup>1</sup>, Schepetkin I.A.<sup>2</sup>*

<sup>1</sup> National Research Tomsk Polytechnic University, 30 Lenin Ave., 634050 Tomsk, Russia

<sup>2</sup> Montana State University, Bozeman, MT 59717, USA

PhD Student

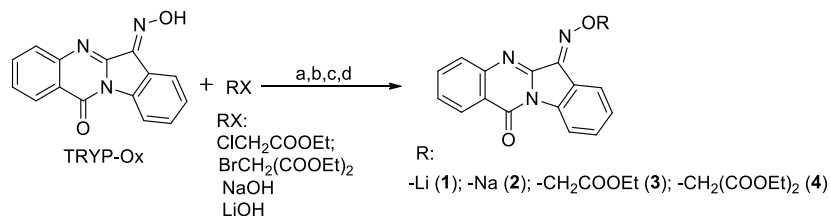
anaskowry@gmail.com

**Introduction:** c-Jun N-terminal kinases (JNK1, JNK2, JNK3) are promising pharmacological targets for the treatment of diseases such as diabetes, atherosclerosis, stroke, coronary heart disease, Alzheimer's and Parkinson's diseases. Indolo[2,1-b]quinazoline-6,12-dione (tryptanthrin) and its substituted derivatives exhibited therapeutic activities such as anti-inflammatory, anti-tumor, anti-microbial, and antiviral. Recently, we first evaluated effects of tryptanthrin-6-oxime as JNK inhibitors [1]. However, most oximes have low solubility, which makes it difficult to develop new pharmacological agents on its basis.

**Methods:** The salts **1** and **2** were prepared from **TRYP-Ox** (1.0 mmol) by treatment with an excess of corresponding LiOH (1.5 mmol) and NaOH (1.5 mmol) in refluxing EtOH or MeOH (10 ml) for 3 h (TLC monitoring). After cooling the precipitate was filtered and recrystallized from EtOH. To a suspension of **TRYP-Ox** (1.0 mmol) and Na<sub>2</sub>CO<sub>3</sub> (2.5 mmol) or KOH (2.5 mmol) in 5 ml DMSO, a solution of alkylation agent (1.50 mmol in 3 ml DMSO) was added dropwise. The mixture was stirred 1 h at room temperature and poured into 150 ml of water. The precipitate was filtered out and recrystallized from EtOH to give **3** and **4** compounds as colorless crystals. A mixture of **TRYP-Ox** (0.3 mmol), alkylation agent (0.45 mmol) and base DBU (0.52 mmol) in MeCN (10 ml) were stirred for 10 min (TLC monitoring). The mixture was then poured into water (150 ml). The resulting precipitate was filtered, washed with water, and recrystallized from EtOH to give identical compounds **3** and **4** as colorless crystals.

**Results:** We have obtained sodium and lithium salts of **TRYP-Ox** (Figure 1) with 88% and 62% yields, respectively. Also, we investigated the reactivity of **TRYP-Ox** towards alkylating reagents in Na<sub>2</sub>CO<sub>3</sub>-DMSO, KOH-DMSO and DBU-MeCN systems (Figure 1). O-alkylation was carried out in Na<sub>2</sub>CO<sub>3</sub>-DMSO system at room temperature using ethyl esters of bromomalonic and monochloroacetic acids. The use of KOH instead of Na<sub>2</sub>CO<sub>3</sub> led to unsuccessful reaction, perhaps, due to a superbasic character of KOH-DMSO medium [2]. For comparison, we have studied the possibility of obtaining O-substituted **TRYP-Ox** analogues in MeCN using DBU as a non-nucleophilic base. Under these conditions, the alkylation proceeded faster (approximately 5 min) than the reaction in the Na<sub>2</sub>CO<sub>3</sub>-DMSO system. Noticeably, the use of DBU as a base is effective for obtaining alkylation products with high yields, while a higher cost of DBU should be taken into account. All products were isomerically pure individual compounds. All products were characterized by <sup>1</sup>H and <sup>13</sup>C NMR, FT-IR, mass spectrometry, and elemental analysis. All the compounds were investigated for binding affinity toward JNK1-3 isoforms, as well as for the cytotoxicity in THP-1Blue cells, and the ability to inhibit lipopolysaccharide (LPS)-induced production of alkaline phosphatase (AP) in THP-1Blue cells. It was discovered that tryptanthrin oxime salts affected cell viability and had the ability to inhibit AP-production in THP-1Blue cells, also they had a high binding affinity to JNK3, while compounds **3** and **4** were inactive, even at the highest tested concentrations.

**Conclusions:** Salts of **TRYP-Ox** show very similar enzymatic activity to **TRYP-Ox** suggesting they are getting converted to **TRYP-Ox** (pKa of oximes is ~11 in water and 26 in DMSO). The higher activity in cell should be due to a pro-drug type effect to increase cell permeability.



**Figure 1.** Reagent and conditions: (a) LiOH in EtOH, reflux, 3 h, **1**, 62% (b) NaOH in MeOH, reflux, 3 h, **2**, 88%; (c) BrCH<sub>2</sub>(COOEt)<sub>2</sub>, ClCH<sub>2</sub>COOEt, Na<sub>2</sub>CO<sub>3</sub> in DMSO, r.t., 1 h, **3**, 33%; **4**, 69%; (d) BrCH<sub>2</sub>(COOEt)<sub>2</sub>, ClCH<sub>2</sub>COOEt, DBU in MeCN, r.t., 5 min, **3**, 71%, **4**, 91%.

## References

- [1] Schepetkin, I.A, et al., *Eur. J. Med. Chem.*, **2019**, 161, 179-191;  
[2] Trofimov, B.A.; Schmidt, E.Y. *Russ. Chem. Rev. (Engl. Transl.)*, **2014**, 83, 600-619.

**Acknowledgements.** This work was supported by the Russian Science Foundation (project number 17-15-01111).

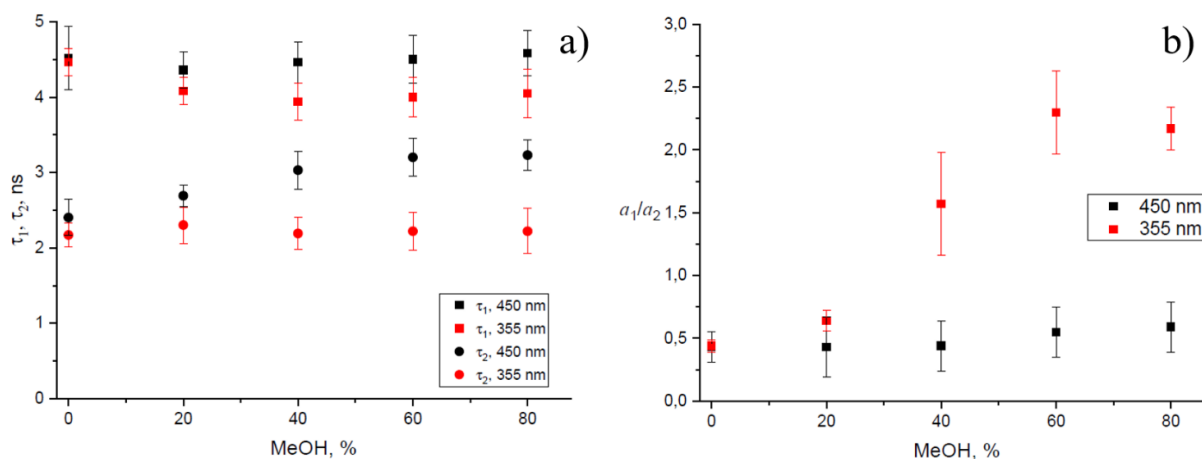
ANISOTROPY AND DECAY TIMES OF FAD FLUORESCENCE IN SOLUTIONS  
UNDER EXCITATION WITHIN ITS FIRST AND SECOND ABSORPTION BANDS

*Krasnopevtseva M.K., Sasin M.E., Gorbunova I.A., Golyshev D.P.,  
Smolin A.G., Belik V.P., Vasyutinskii O.S.*

Ioffe Institute, Saint Petersburg, Russia  
Marina.krasnopevtseva@gmail.com

Flavin adenine dinucleotide (FAD) in its oxidized ( $\text{FAD}^+$ ) and reduced ( $\text{FADH}_2$ ) forms is an intracellular coenzyme involved in redox reactions in living cells. As known,  $\text{FAD}^+$  is able to fluoresce, but  $\text{FADH}_2$  is not. This important feature makes it possible to use FAD as a fluorescent probe for studying biochemical processes in living cells [1]. In this paper anisotropy, lifetimes, and rotational diffusion time of FAD in water-methanol solutions have been determined from experiment and analysed. Fluorescence was excited by picosecond laser pulses (the setup used was similar to that described in our previous study [2]) at 355 nm and 450 nm.

Figure 1 presents fluorescence decay times  $\tau_1$  and  $\tau_2$  (a) and the ratio of corresponding weighting coefficients  $a_1/a_2$  (b).



**Figure 1.** Fluorescence decay times  $\tau_1$  and  $\tau_2$  (a) and weighting coefficients ratio  $a_1/a_2$  (b).

Theoretical models describing relaxation processes in FAD after excitation by a short laser pulse were created based on the analysis of the experimental results obtained and the quantum-chemical calculations performed.

#### References

- [1] Galbán, J., Sanz-Vicente, I., Navarro, J., de Marcos, S. *Methods Appl. Fluoresc.* **2016**. 4 (4) 042005.
- [2] Krasnopevtseva M.K., Belik V.P., Semenova I.V., Smolin A.G., Bogdanov A.A., Vasyutinskii O.S. *Tech. Phys. Lett.* **2020**. 46 (6) 614-616.

This work was supported by the Russian Foundation for Basic Research (project No 18-53-34001).

# SYNTHESIS AND PROPERTIES OF ALLYL AND PROPARGYL DERIVATIVES OF 2-AMINOPYRIMIDINE

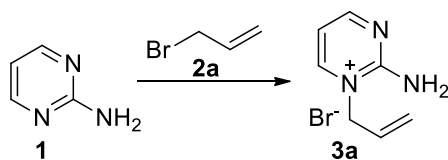
*Krynina E.M.<sup>1</sup>, Kalita E.V.<sup>1</sup>, Kim D.G.<sup>1</sup>*

<sup>1</sup>South Ural State University, Chelyabinsk, Russia  
Student  
[emkrynina@yandex.ru](mailto:emkrynina@yandex.ru)

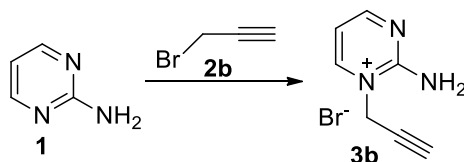
There are no data of allyl and propargyl derivatives of 2-aminopyrimidine in the literature. It has been known that 2-aminopyrimidine exhibits antibacterial activity against *Streptococcus pyogenes* [1].

In this work, we have studied the interaction of 2-aminopyrimidine (**1**) with allyl bromide (**2a**) and propargyl bromide (**2b**) in butanol in the absence of a base with heating under reflux. The reaction has proceeded at the endocyclic nitrogen atom with the formation of 1-allyl-2-aminopyrimidinium bromide (**3a**) and 2-amino-1-propargylpyrimidinium bromide (**3b**), as in the case of 2-aminopyridine [2].

In the <sup>1</sup>H NMR spectra of bromides **3a** и **3b**, signals of the pyrimidine ring protons have been shifted to a weak field by 0.55–0.61 ppm compared to the original 2-aminopyrimidine, which is due to the appearance of a positive charge at the nitrogen atom.



**Figure 1.** Synthesis of 1-allyl-2-aminopyrimidinium bromide (**3a**)



**Figure 2.** Synthesis of 2-amino-1-propargylpyrimidinium bromide (**3b**)

1-Allyl-2-aminopyrimidinium bromide **3a** has been researched for antibacterial activity against *Escherichia coli* ATCC 25922, it exhibits efficiency.

## References

- [1] Wójcik M., Eleftheriadis N., Zwinderman M.R.H., Dömling A.S.S., Dekker F.J., Boersma Y.L. *Eur. J. Med. Chem.* **2019**, *161*, 93–100  
[2] Kalita E.V., Kim D.G, Rakhmatullina D.A., Pylneva M.A., Krynina E.M. *Russ. J. Gen. Chem.* **2019**, *89*, 1570–1574

# TRIS(3-AMINOPROPYL)AMINE-DERIVED MACROCYCLIC FLUORESCENT DETECTORS

*Kuliukhina D.S., Chernichenko N.M., Averin A.D., Beletskaya I.P.*

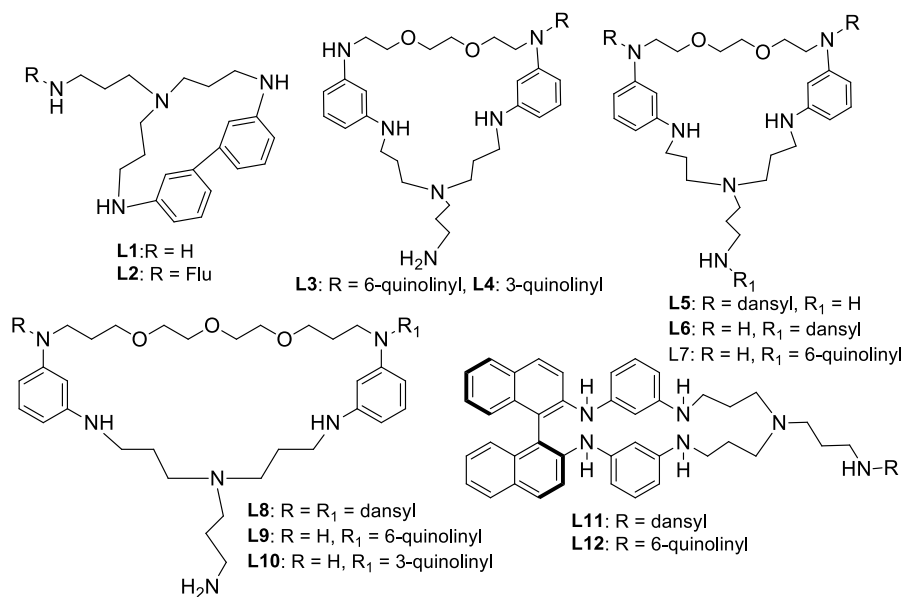
Lomonosov Moscow State University, Department of Chemistry, Moscow, Russia

PHD Student

[kuliukhinadaria03@gmail.com](mailto:kuliukhinadaria03@gmail.com)

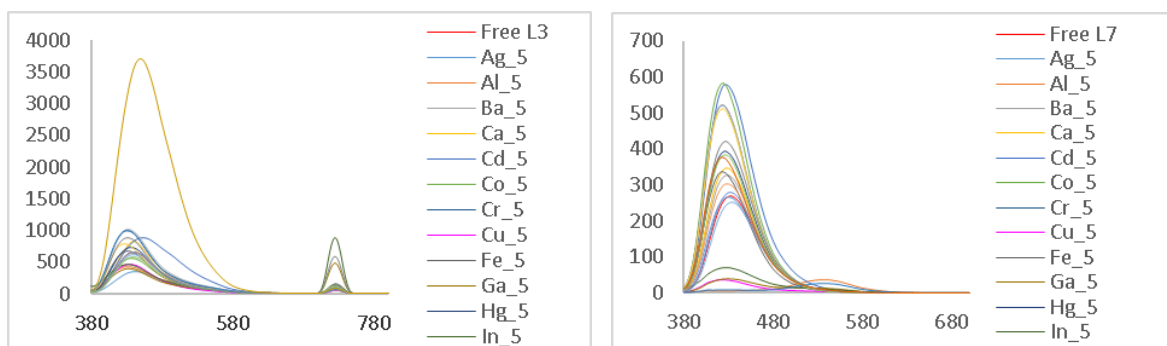
Detection of metal cations and optically active substances is of interest for investigations in chemistry, biology, clinical biochemistry and ecology. One of numerous analytical methods for determination of cations is based on the use of luminescent and colorimetric sensors that have several advantages, such as sensitivity, selectivity, and short response time. In this connection, considerable efforts have been made in the laboratory of organoelement compounds of the Moscow State University to develop methods for the synthesis of selective fluorescent and colorimetric detectors.

In this work we compare the detection of various metal cations of tris(3-aminopropyl)amine derivatives; besides, chiral macrocyclic derivative of this tetraamine comprising endocyclic (*S*)-BINAM moiety was also studied as enantioselective fluorescence detector of model amino alcohols. The Pd(0)-catalyzed amination method for macrocyclization and the introduction of fluorophore groups has been widely used. (Figure 1).



**Figure 1.** Macrocyclic fluorescent detectors

The synthesized compounds were studied by UV- and fluorescence spectroscopy and their use as fluorescent detectors for such metal cations as Zn(II), Al(III), Hg(II), Cu(II), Pb(II) was shown to be possible due to selective changes in fluorescence spectra. Totally a panel 21 metal perchlorates was investigated. The detection ability of the chiral macrocyclic derivatives of BINAM was studied using a series of amino alcohols.



**Figure 2.** L3 and L7 fluorescence spectra in the presence of various metal salts.

Acknowledgements. This work was supported by the Russian Foundation for Basic Research (project No 18-03-00709).

STUDY OF THE INTERACTION OF GLUTATHIONE WITH DINITROSYL IRON COMPLEX  
WITH N, N' - DIMETHYLTHIOUREA LIGANDS

*Kusyapkulova A.B.*<sup>1,2</sup>, *Pokidova O.V.*<sup>2</sup>, *Kulikov A.V.*<sup>1,2</sup>, *Sanina N.A.*<sup>1,2,3</sup>

<sup>1</sup>Lomonosov Moscow State University, Moscow, Russia

<sup>2</sup>Institute of Problems of Chemical Physics, Russian Academy of Sciences, Chernogolovka,  
Moscow Region, Russia

<sup>3</sup>Medicinal Chemistry Research and Education Center, Moscow Region State University,  
Mytishchy, Moscow Region, Russia

Student

[kusyapkulova.albina@yandex.ru](mailto:kusyapkulova.albina@yandex.ru)

In recent years, it has been reliably established that iron-sulfur-nitrosyl complexes are considered a relatively stable form of NO *in vivo* [1]. Their synthetic analogs, dinitrosyl complexes (DNICs), have several advantages over other classes of exogenous NO donors. Such advantages are presence in their structure of not only NO groups, but also functional thioligands. DNICs are effective at low therapeutic doses and do not require an activation for NO generation. In this work, we investigated the complex  $[\text{Fe}(\text{SC}(\text{NHCH}_3)_2)_2(\text{NO})_2]\text{BF}_4$  [2] from DNICs family, which is a promising compound for the treatment of socially significant diseases. Complex reduces viability and inhibits the proliferation of multiple myeloma cell [3]. The study of the mechanisms of decomposition and further transformation of DNIC *in vivo* is an important stage of research from the point of view of further use of this class of compounds. Particular attention should be paid to the possible reactions of the exchange of DNIC thiol ligands for biologically important thiols *in vivo*. GSH was chosen as one of these intracellular thiols. It is the most abundant non-protein thiol in living organisms and has many functions [4].

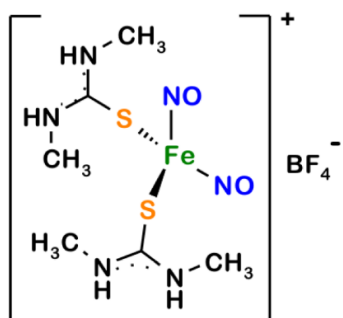


Figure 1.  $[\text{Fe}(\text{SC}(\text{NHCH}_3)_2)_2(\text{NO})_2]\text{BF}_4$  structure.

The aim of this work is to study the interaction of reduced glutathione with a nitrosyl complex with N, N'-dimethylthiourea ligands.

In the course of the work, the decomposition of DNIC in an aqueous buffer solution and in the presence of GSH was studied using UV-Vis spectroscopy, Griess reaction and EPR spectroscopy. In the system with GSH, two maxima appear in the absorption spectrum at 312 and 363 nm, which are absent in the spectrum of the initial complex, while the EPR signal with  $g = 2.03$  disappears. This indicates the formation of a binuclear complex with  $\text{GS}^-$  ligands, which is a more stable compound than the initial DNIC.

### References

- [1] Vanin, A.F. *FEBS Letters* **1991**, 289, 1–3.
- [2] Shmatko N.Yu, Korchagin D.V., Shilov G.V., et.al. *Polyhedron* **2017**, 137, 72–80.
- [3] Akentieva N.P., Sanina N.A., Prichodchenko T.R., Gizatullin A.R., Shkondina N.I., Shushanov S.S., Stupina T.S., Aldoshin S.M. *Dokl. Biochem. Biophys.* **2019**, 486, 238–242.
- [4] Kalinina E.V., Chernov N.N., Novichkova M.D. *Biochemistry* **2014**, 79, 1562-1583.

Acknowledgements. This work was supported by president grant No MK-1634.2021.1.3

# SYNTHESIS OF PHOTOCLEAVABLE PORPHYRIN-COMBRETASTATIN CONJUGATES FOR COMBINED THERAPY OF CANCER

*Kuzmina N.S.<sup>1</sup>, Otvagin V.F.<sup>1</sup>, Maleev A.A.<sup>1</sup>, Nyuchev A.V.<sup>1</sup>, Fedorov A.Yu.<sup>1</sup>*

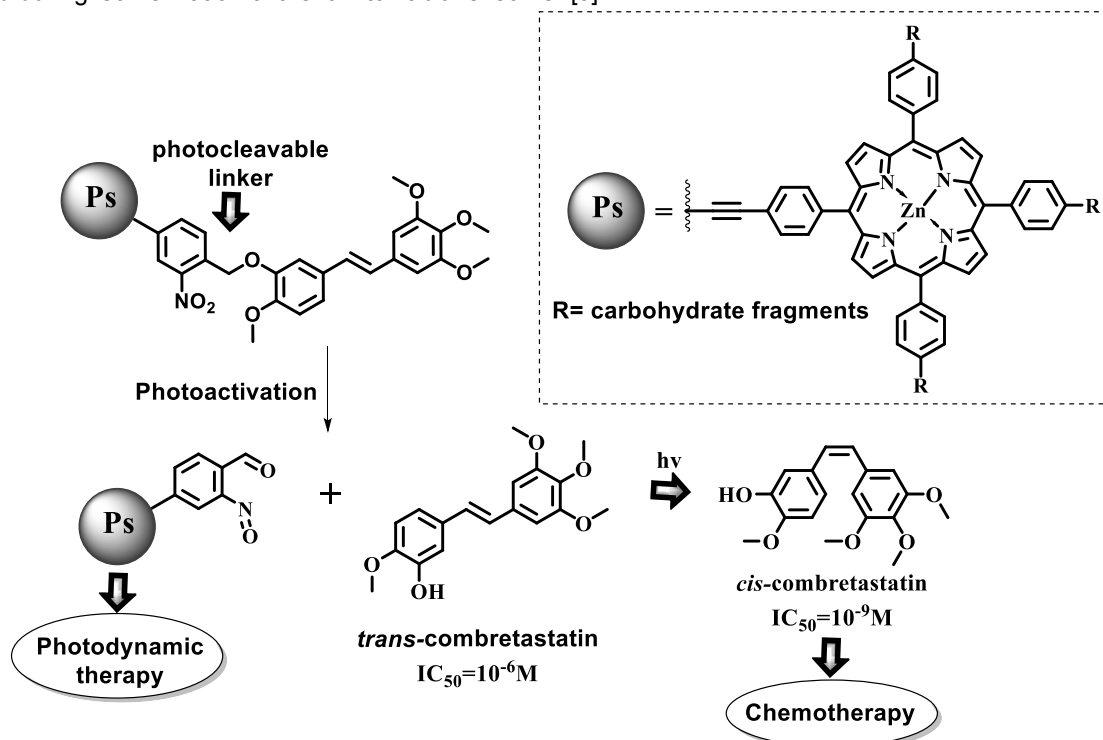
<sup>1</sup>N.I. Lobachevsky State University of Nizhny Novgorod, Nizhny Novgorod, Russia

PhD student

[kuzmina.ns2014@gmail.com](mailto:kuzmina.ns2014@gmail.com)

The multidrug resistance of tumors and significant general toxicity are the main problems of modern chemotherapy [1]. The first problem can be solved using combination therapy approaches. The general way to reduce the systemic toxicity of drugs is the use of their prodrug forms.

In this work new hybrid photoactive conjugates consisting of a synthetic porphyrin photosensitizer (Ps), a photocleavable linker, a therapeutic agent (combretastatin A4), and carbohydrates were synthesized [2]. The *o*-nitrobenzyl linker binds the *trans*-combretastatin in an inactive form and releases it upon light irradiation (Fig. 1). Also, the action of light makes it possible to activate the chemotherapeutic drug, *cis*-combretastatin A4, which is formed during isomerization of the low-toxic *trans*-isomer [3].



**Figure 1.** The conception of photocleavable conjugates

For synthesized conjugates photophysical characteristics were investigated and theoretical calculations were performed.

## References

- [1] Dumontet C., Jordan M. A., *Nat. Rev.*, **2010**, 9, 790-803.
- [2] Kuzmina N.S., Otvagin V. F., Krylova L. V., Nyuchev A. V., Romanenko Y. V., Koifman O. I., Balalaeva I. V., Fedorov A. Yu. *Mendeleev Commun.* **2020**, 30(2), 159-161.
- [3] Scherer K. M., Bisby R. H., Botchway S. W., Hadfield J. A., Parker A. W. *J. Biomed. Opt.*, **2015**, 20(5), 051004-1 – 051004-6.



BF<sub>3</sub>-MEDIATED C-LI/C-H COUPLING OF 1,3,7-TRIAZAPYRENE WITH LITHIUM ALKYNES –  
A CONVENIENT SYNTHETIC STRATEGY TOWARDS NOVEL *aza*-PAHS

*Lavrinenko I.A.*<sup>1</sup>, *Moseev T.D.*, *Varaksin M.V.*<sup>1,2</sup>, *Charushin V.N.*<sup>1,2</sup>, *Chupakhin O.N.*<sup>1,2</sup>

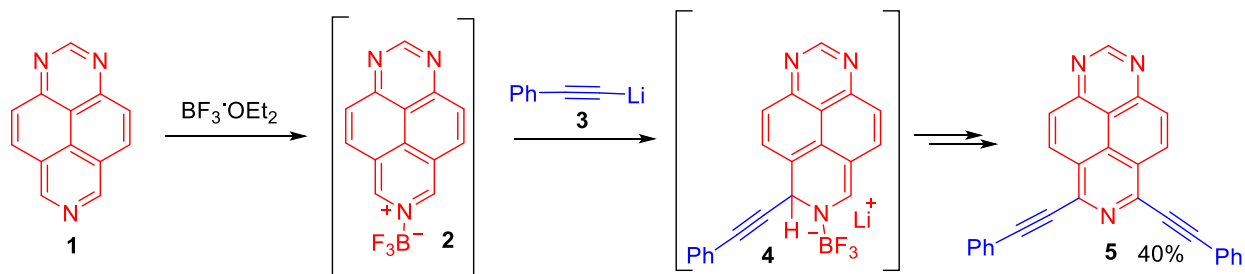
<sup>1</sup>Ural Federal University, 19 Mira Str., 620002 Ekaterinburg, Russia

<sup>2</sup>Institute of Organic Synthesis, Ural Branch of the Russian Academy of Sciences, 22 S. Kovalevskaya Str.,  
620990 Ekaterinburg, Russia

[m.v.varaksin@urfu.ru](mailto:m.v.varaksin@urfu.ru)

*aza*-Polycyclic aromatic hydrocarbons (*aza*-PAHs) have a wide practical application in molecular electronics, *e.g.*, organic photovoltaics (OPVs), organic light-emitting diodes (OLEDs), and organic field-effect transistors (OFETs) as well. Hence, according to the literature data the direct functionalization of them are very limited. We exploited the methodology of nucleophilic substitution of hydrogen (S<sub>N</sub><sup>H</sup>) of the model *aza*-PAH, 1,3,7-triazapyrene, to process the nucleophilic modification.

The synthetic scheme and possible mechanism are presented in Figure 1. In the first step, the complex **2** of 1,3,7-triazapyrene **1** and BF<sub>3</sub> was obtained using BF<sub>3</sub>·OEt<sub>2</sub> (1.1 equiv.) in THF to *aza*-PAH **1**. Subsequently, the interaction of the latter with alkynyl-lithium salt **3** via the formation of intermediate **4** leads to the corresponding mono-substituted derivatives, which are not able to be isolated in this case. Meanwhile, disubstituted triazapyrene **5** was prepared in 40% yield, the structure of the novel disubstituted compound was confirmed by NMR, mass-spectrometry, and elemental analysis data.



**Figure 1.** BF<sub>3</sub>-mediated C-Li/C-H coupling of 1,3,7-triazapyrene and alkynyl-lithium

In summary, a convenient synthetic procedure to the synthesis of disubstituted 1,3,7-triazapyrenyl derivatives was developed. The next research are aimed to expand the scope and limitation (in particular for both *aza*-PAH and alkenyl side), as well as to complete the photophysical studies.

#### References

[1] Moseev T.D., Lavrinenko I.A, Varaksin M.V., Pobedinskaya D.Yu., Demidov O.P., Borovlev I.V., Charushin V.N., Chupakhin O.N. *RSC Adv.*, **2021**,11,6407-6414

Acknowledgements. The research was financially supported by the Council on Grants of the President of the Russian Federation for State Support of Young Russian Scientists – Candidates of Sciences (Project No. MK-1196.2020.3, Agreement No. 075-15-2020-506).

# PRIMARY VINYL ETHERS IN THE SYNTHESIS OF DEUTERIUM-LABELED PYRAZOLES

Lebedev A.N.,<sup>1</sup> Ledovskaya M.S.,<sup>1</sup> Voronin V.V.<sup>1</sup> and Ananikov V.P.<sup>1,2</sup>

<sup>1</sup>Saint Petersburg State University, Saint Petersburg, Russia

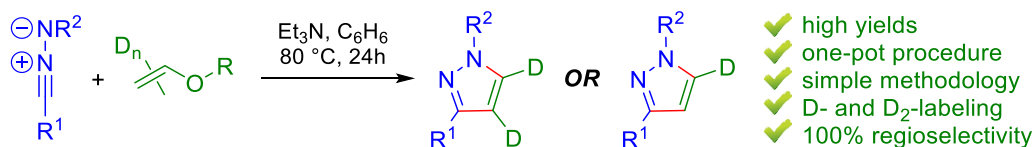
<sup>2</sup>N. D. Zelinsky Institute of Organic Chemistry Russian Academy of Sciences, Moscow, Russia

Student

[st069187@student.spbu.ru](mailto:st069187@student.spbu.ru)

With the triple bond prone to additions and two active C-bonded protons, acetylene is invaluable for a variety of transformations [1]. However, its synthetic potential cannot be fully implemented because bulk gaseous acetylene is flammable and explosive [2]. Among the acetylene surrogates, calcium carbide represents a highly efficient and convenient acetylene source [3-4]. Despite its convenience, deuteration with CaC<sub>2</sub> is of limited scope and requires application of aprotic or deuterated solvents to achieve high levels of deuterium incorporation [3-4].

Studying vinyl ethers and their deuterated derivatives, we stumbled across an interesting opportunity of applying them as acetylene surrogates. In this study, for the first time was proposed a detailed mechanistic investigation of the reaction between vinyl ethers and *in situ* generated nitrile imines, resulting into the novel synthetic approach to 1,3-disubstituted pyrazoles, 4,5-dideuteropyrazoles and regioselectively-labeled 5-deuteropyrazoles [5]. We tested a scope of nitrile imine sources, hydrazoneyl chlorides, to obtain a variety of pyrazoles in up to 99% yields.



**Scheme 1.** Deuterated vinyl ethers in D-labeled pyrazoles synthesis.

## References

- [1] Diederich F., Stang P.J., Tykwinski R.R. *Acetylene Chemistry: Chemistry, Biology, and Material Science*, Wiley-VCH Verlag GmbH & Co. KGaA, Weinheim, **2005**
- [2] Voronin V. V., Ledovskaya M.S., Bogachenkov A.S., Rodygin K.S., Ananikov V.P. *Molecules* **2018**, *23*, 2442.
- [3] Voronin V. V., Ledovskaya M. S., Gordeev E. G., Rodygin K. S., Ananikov V. P. *J. Org. Chem.* **2018**, *83*, 3819.
- [4] Ledovskaya M. S., Rodygin K. S., Ananikov V. P., *Org. Chem. Front.* **2018**, *5*, 226.
- [5] Ledovskaya M.S., Voronin V.V., Polynski M.V., Lebedev A.N., Ananikov V.P. *Eur. J. Org. Chem.* **2020**, 4571.

**Acknowledgements.** We gratefully acknowledge the financial support from the Russian Science Foundation (Project № 19-73-10032).

## CALCIUM CARBIDE IN THE SYNTHESIS OF HETEROCYCLES

Ledovskaya M.S.<sup>1</sup>, Voronin V.V.,<sup>1</sup> Rodygin K.S.,<sup>1</sup> Lebedev A.N.,<sup>1</sup> Ananikov V.P.<sup>1,2</sup>

<sup>1</sup>Saint Petersburg State University, Saint Petersburg, Russia

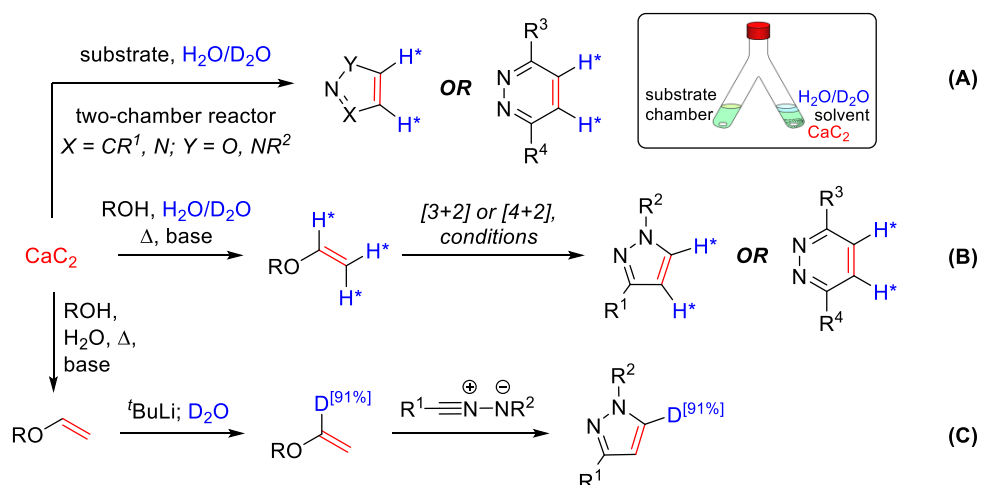
<sup>2</sup>N. D. Zelinsky Institute of Organic Chemistry Russian Academy of Sciences, Moscow, Russia

Researcher

[m.ledovskaya@spbu.ru](mailto:m.ledovskaya@spbu.ru)

Calcium carbide is a versatile reagent for organic synthesis. Reacting with water, it gives acetylene; and a wide variety of synthetic procedures is based on this chemical property of calcium carbide [1]. In this way, a range of vinyl derivatives, substituted alkynes, pyrroles, pyrazoles, benzofurans, and other heterocyclic compounds were successfully synthesized [1,2].

Our researches included an application of calcium carbide in the synthesis of five- and six-membered heterocycles and some valuable building blocks. In particular, the use of calcium carbide – water (or D<sub>2</sub>O) mixture for acetylene and dideuteroacetylene generation in two-chamber reactor (Scheme 1, path **A**) is a convenient synthetic path to a range of pyrazoles [3], isoxazoles [4], triazoles, 3,6-disubstituted pyridazines [5] and their D<sub>2</sub>-labeled derivatives. Reacting with alcohols, CaC<sub>2</sub>-H<sub>2</sub>O(D<sub>2</sub>O) mixture gives vinyl ethers or their trideuterated derivatives (Scheme 1, Path **B**) [6,7]. The latter can be applied as acetylene/acetylene-D<sub>2</sub> surrogates in [3+2] and [4+2] cycloaddition reactions with base-sensitive or low reactive substrates leading to pyrazoles [6] or pyridazines and their deuterated derivatives (Scheme 1, Path **B**). A regioselective replacement of hydrogen to deuterium in vinyl ether allowed to synthesize a valuable building block, alkyl 1-deuteroacetylene (Scheme 1, path **C**). The reaction of 1-deuteroacetylene and nitrile imines was regioselective and led to 5-deuteropyrazoles in good to excellent yields [6].



### References

- [1] Rodygin K.S., Ledovskaya M.S., Voronin V.V., Lotsman K.A., Ananikov V.P. *Eur. J. Org. Chem.*, **2021**, 2021, 43-52.
- [2] Voronin V. V., Ledovskaya M. S., Bogachenkov A. S., Rodygin K. S., Ananikov V. P. *Molecules*, **2018**, 23, 2442.
- [3] Voronin V.V., Ledovskaya M.S., Gordeev E.G., Rodygin K.S., Ananikov V.P. *J. Org. Chem.*, **2018**, 83, 3819-3828.
- [4] Ledovskaya M.S., Rodygin K.S., Ananikov V.P. *Org. Chem. Front.*, **2018**, 5, 226-231.
- [5] Ledovskaya M.S., Voronin V.V., Rodygin K.S., Ananikov V.P. *Org. Chem. Front.*, **2020**, 7, 638-647
- [6] Ledovskaya, M.S.; Voronin, V.V.; Polynski, M.V.; Lebedev, A.N.; Ananikov, V.P. *Eur. J. Org. Chem.*, **2020**, 4571-4580.
- [7] Ledovskaya M.S., Voronin V.V., Rodygin K.S., Posvyatenko A.V., Egorova K.S., Ananikov V.P. *Synthesis*, **2019**, 51, 3001-3013.

Acknowledgments. This work was supported by the Grant Council of the President of the Russian Federation (MK-2615.2021.1.3).

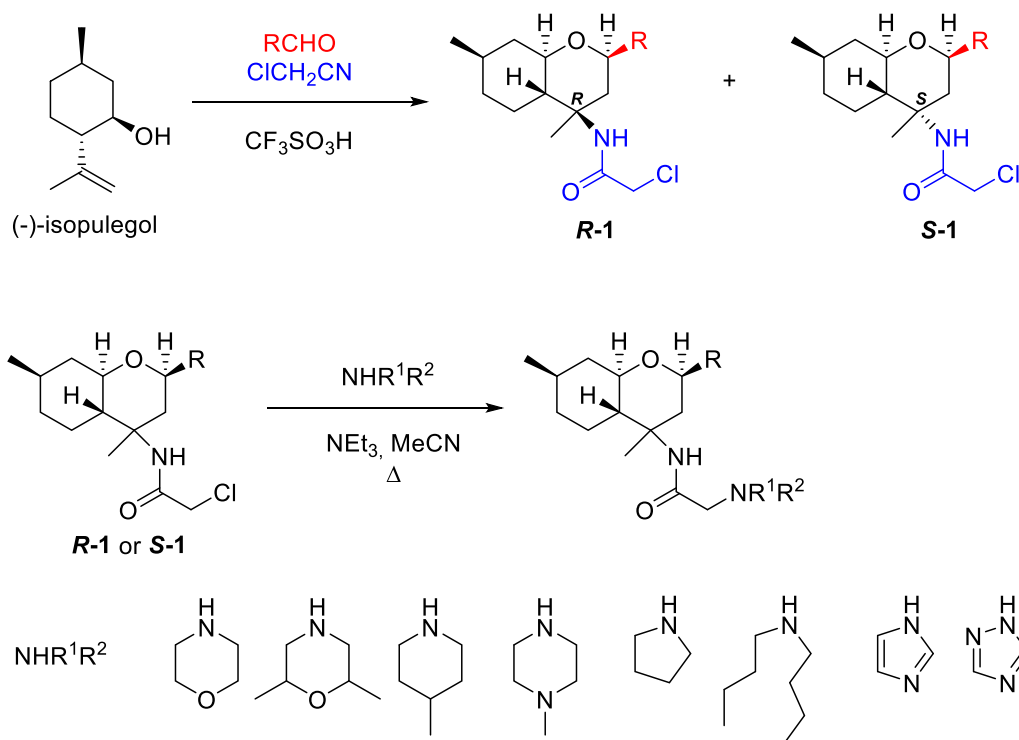
# SYNTHESIS OF AMIDE-AMINE DERIVATIVES OF OCTAHYDROCHROMENE – PERSPECTIVE ANALGESIC AGENTS

*Li-Zhulanov N.S., Pavlova A.V., Volcho K.P., Salahutdinov N.F.*

N.N. Vorozhtsov Novosibirsk Institute of Organic Chemistry SB RAS, Akademika Lavrentieva Ave. 9,  
Novosibirsk, 630090, Russia  
Young Scientist  
[lizhulanov@mail.ru](mailto:lizhulanov@mail.ru)

Selective modification of natural structures is one of the most important ways to develop and search for new biologically active substances of various types. Recently, it was found that the compounds with octahydro-2*H*-chromene scaffold, obtained by reaction of monoterpene (-)-isopulegol with various aldehydes on montmorillonite clay K10, have high analgesic activity in *in vivo* tests in mice [1-3].

In the present work we use the Prins-Ritter cyclization between (-)-isopulegol, aldehydes and chloroacetonitrile. This three component one-pot tandem reaction resulted in the chiral amide derivatives of octahydrochromene **R-1** and **S-1** in one step. Using of chloroacetonitrile as *N*-nucleophile allow us to carry out further modifications by substitution of chlorine atom. Interaction of chloroamides **1** with a number of secondary amines gives an amide-amine octahydrochromenes.



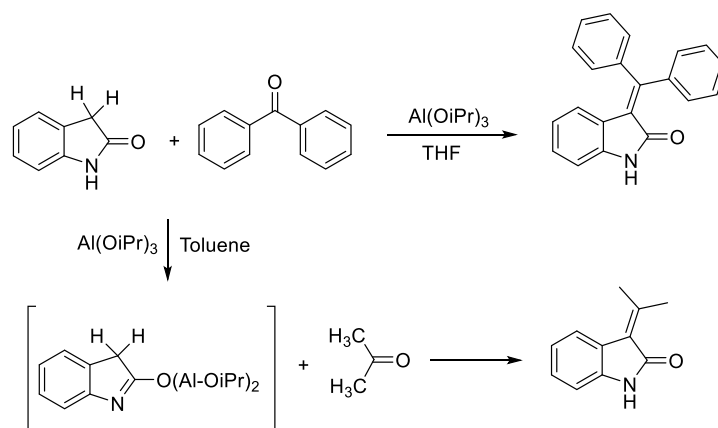
Development of new analgesic agents with high activity and low toxicity is very important task. It is known that the heterocyclic compounds synthesized from (-)-isopulegol can exhibit analgesic activity. When studying the analgesic activity of the synthesized compounds *in vivo*, it was found that a number of derivatives exhibited high analgesic activity comparable with the reference drug sodium diclofenac.

## References

- [1] Il'ina I.V., et al. *Letters in Drug Design & Discovery*. **2020**, 17(1), 68–78
- [2] Li-Zhulanov N.S., et al. *Med. Chem. Res.* **2019**, 28(4), 450-464
- [3] Nazimova E.V. et al., *Med. Chem. Res.* **2016**, 25(7), 1369-1383.

Development of methods for selective activation of unmodified C–H bonds is a modern tool for designing the most effective, economical and environmentally friendly synthesis schemes for a wide range of biologically active compounds. The specificity of such methods allows one to exclude intermediate functionalization stages of corresponding fragments of the carbon skeleton within intermediate substrates. The use of metal-free methods corresponds to the current trends in the C–H bond functionalization without recruiting halogens or halogenoids as leaving groups.

Previously, when developing methods for obtaining compounds that stimulate AMP-activated protein kinase, we proposed aluminum isopropoxide as a catalyst for the Knoevenagel condensation of oxindole, a non-classical C–H active substrate [1]. The use of this catalyst allowed us to significantly increase the yield of target compounds. However, in the course of research it was found that in some cases this alkoxide can act not only as a catalyst, but also generate an active particle with the subsequent formation of the corresponding product. This can be schematically represented as two competing reactions (Figure 1).



**Figure 1.** Competing reactions during the interaction of oxindole with carbonyl compounds

The course of these two processes was investigated in detail. The effect of the solvent, alkoxide used and oxindole substituents on the nature and direction of the condensation was assessed. In the study, a number of intermediate products were obtained, which will be further used to obtain new active structures.

Thus, metal alkoxides are not only effective activators of C–H bonds, but also a new tool for organic synthesis.

### References

[1] Novikova D.S., Grigoreva T.A., Zolotarev A.A., Garabadzhiu A.V., Tribulovich V.G. *RSC Advances.*, **2018**, *8*, 34543–34551.

Acknowledgements. This work was supported by the Russian Science Foundation (project no. 19-73-10150).

# SYNTHESIS AND PHOTOPHYSICAL PROPERTIES OF NEW FLUORESCENT DYES BASED ON BODIPY DERIVATIVES AND SILOXANE MATRICES

*Maksimova M.A.*<sup>1,2</sup>, *Kim E.E.*<sup>2</sup>, *Kononevich Yu.N.*<sup>2</sup>, *Ionov D.S.*<sup>3</sup>, *Anisimov A.A.*<sup>2</sup>, *Shchegolikhina O.I.*<sup>2</sup>, *Pakhomov A.A.*<sup>2,4</sup>, *Muzafarov A.M.*<sup>2,5</sup>

<sup>1</sup>Lomonosov Moscow State University, Department of Chemistry, Moscow, Russia

<sup>2</sup>A.N. Nesmeyanov Institute of Organoelement Compounds of Russian Academy of Sciences, Moscow, Russia

<sup>3</sup>Photochemistry Centre, FSRC "Crystallography and Photonics" of Russian Academy of Sciences, Moscow, Russia

<sup>4</sup>Shemyakin-Ovchinnikov Institute of Bioorganic Chemistry of Russian Academy of Science, Moscow, Russia

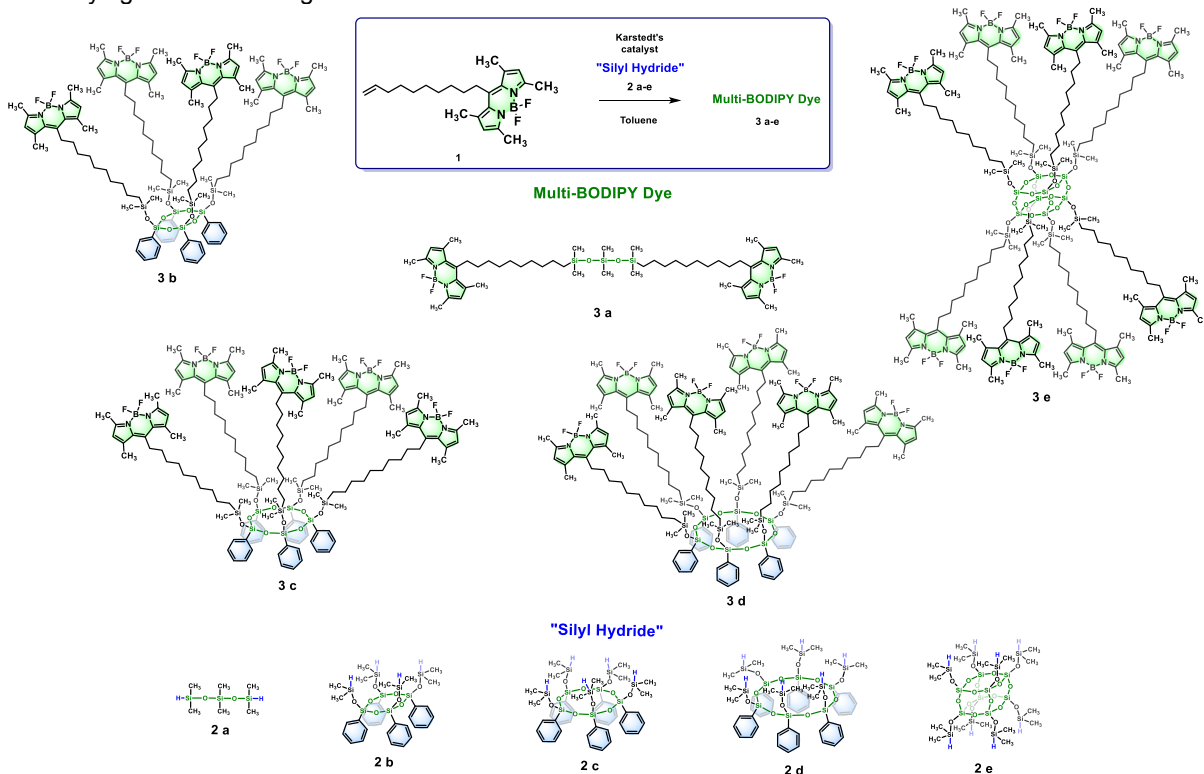
<sup>5</sup>N.S. Enikolopov Institute of Synthetic Polymeric Materials of Russian Academy of Science, Moscow, Russia

Student

[ritamax2000@yandex.ru](mailto:ritamax2000@yandex.ru)

Currently, the processes occurring in living organisms are often studied by detailed consideration of the distribution, localization, movement and interaction of molecules at all levels of organization of living systems, from the cellular to the organismic. Most of the compounds in the cell are colorless, so observation of biomolecules almost always requires the researcher to introduce some kind of label. The use of fluorescent labels has a number of significant advantages. Among them there are safety, low toxicity, variety and high sensitivity of modern fluorescent detectors. BODIPY-based dyes have all of the above characteristics. Also, the ideal bioimaging fluorescent label should be bright.

To increase the brightness of fluorescent labels an approach based on the synthesis of molecules containing several fluorophores with the above properties was developed. Thus, the extinction of the dyes should be increased proportionally to the amount of fluorophores. Siloxane cycles can be used as a template for BODIPY molecules due to their high stability, optical characteristics, and tunable size of cycle, so these matrixes allow varying the number of grafted fluorescent molecules.



**Figure 1.** Synthesis of multifluorophoric BODIPY-based dyes 3 a-e.

In this work, a series of multichromophoric compounds were synthesized via conjugation of *meso*-decene-BODIPY with functional stereoregular cyclosiloxanes by the hydrosilylation reaction. The structures of all obtained compounds were confirmed by NMR-, IR-spectroscopy and mass spectrometry. Absorption and fluorescence spectra of the synthesized compounds in various solvents were studied, the extinction coefficient and quantum yield were determined, and the fluorescence lifetimes of dyes were investigated.

Acknowledgements. This work was supported by the Russian Science Foundation (project No 19-73-20194).

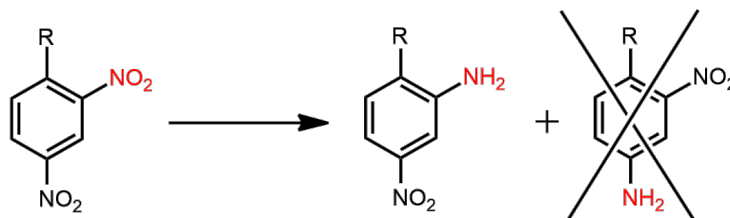
REGIOSELECTIVE DINITROARENE REDUCTION METHODS: DEVELOPMENT,  
OPTIMIZATION AND COMPARISON

*Maksutova A.I., Tsymliaikov M.D., Bezsonova E.N., Zakharova D.V.,  
Tafeenko V.A., Sosonyuk S.E., Lozinskaya N.A.*

Moscow State University, Moscow, Russia  
Student

[anita.maksutova@gmail.com](mailto:anita.maksutova@gmail.com)

The regioselective reduction reaction, shown in Figure 1, is highly convenient synthetically while being crucial for obtaining of some substances, which cannot be synthesized otherwise. The information about this reaction in literature is fragmented: most authors report either only 1-2 successfully reduced model compounds per article, or the method is not completely regioselective. Moreover, most methods require expensive reagents, for example noble metals. Both methods, proposed in this work, are far more versatile and highly selective, while being rapid in mild conditions and use only cheap and accessible reagents.



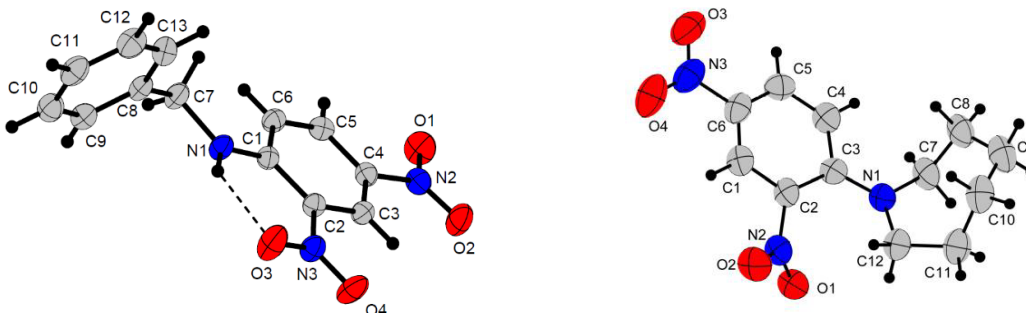
**Figure 1.** Regioselective dinitroarene reduction (R=Alk, OH, NH<sub>2</sub>, Alk<sub>2</sub>N, ArNH, BnNH, COOH, Cl).

The method A (Table 1) is versatile and preparative, but problems with isolation upscaling led us to searching for another reducing system. Next, method B was found and studied. Despite the high yields, method B is not entirely multipurpose. High nucleophilic properties of hydrazine somewhat narrow its applicable scope compared to sodium dithionite.

**Table 1.** Comparison of the condition and results of the two methods.

	Method A	Method B
Reagents; solvent	Na <sub>2</sub> S <sub>2</sub> O <sub>4</sub> ; H <sub>2</sub> O/THF	N <sub>2</sub> H <sub>4</sub> *H <sub>2</sub> O, FeCl <sub>3</sub> *6H <sub>2</sub> O, C <sub>act</sub> ; EtOH
Yield	Average at 30-40%, up to 69%	Average at 70-80%, up to 92%

Catalytic and regioselectivity mechanisms were proposed. N-monosubstituted 2,4-dinitroanilines form an intramolecular hydrogen bond with the *ortho*-nitrogroup, which activates the regioselective reduction by withdrawing and rearranging the electron density within a six-membered system. In case of N,N-disubstituted anilines, the *ortho*-nitro group is out of the plane because of more sterically hindered substituents, which interrupts its conjugation with the aromatic system. Assumptions about regioselectivity were additionally substantiated by single crystal X-ray structural data, obtained in this work. (Figure 2).



**Figure 2.** Single crystal X-ray diffraction study of 2,4-dinitro-N-benzylaniline and 1-(2,4-dinitrophenyl)azepane

Thus, two different preparative methods A and B (Table 1) of regioselective reduction were developed in this work. A sheer library of 2-amino-4-nitroarenes were successfully obtained with high to excellent yields.

Acknowledgements. This work was supported by the Russian Foundation for Basic Research (Project 20-03-00915).

# OZONATION KINETICS OF NUCLEIC BASES IN AQUEOUS SOLUTIONS

Maksyutova A.A

Bashkir State University, Ufa, Russia  
Postgraduate  
[ajm-ajms@mail.ru](mailto:ajm-ajms@mail.ru)

Nucleic bases (NB) are the most important components of nucleic acids. They are responsible for a construction of RNA and DNA chains. Five nucleic bases are occurred in nucleic acids: there are uracil and its derivatives (thymine and cytosine) called pyrimidine bases, and adenine and guanine called purine bases. It is known that various breakage types of monomer link integrity of RNA and DNA chains, in particularly by oxidants, lead to different forms of hard diseases. In present time the studies are conducted in different science places of plausible mechanism detecting of nucleic base oxidation and finding of path of its prevention. Herewith the reactions of nucleic base oxidation used are model reactions in the vast majority of cases. It ought to be noted that ozone which gained widespread appreciation in general therapy of diseases and cosmetology in the last decades is not presented in the middle of the used oxidants in due course (singular references [1-2]). In this connection the studies which are focused on studying of ozone oxidation kinetics of nucleic bases acquire the topicality.

Kinetics of ozone reaction with nucleic bases in aqueous solutions was studied by method of UV-spectroscopy in UV-2600 "Shimadzu" company appliance. As an object of study four NB were used: there are adenine, thymine, uracil and cytosine. In first stage the coefficients of extinction of NB which are used for estimation of its residual concentrations determined by dint of Bouguer-Lambert-Beer law:

Nucleic bases	Adenine	Thymine	Uracil	Cytosine
$\varepsilon_{NB} \cdot 10^{-3}, l \text{ mol}^{-1} \text{ cm}^{-1}$	$9.3 \pm 0.3$	$6.8 \pm 0.1$	$8.4 \pm 0.2$	$3.1 \pm 0.1$
$\lambda_{max}, \text{ nm}$	260	264	257	267

In second stage the ozone oxidation kinetics of nucleic bases was studied in aqueous solutions with equal initial concentrations of reagents ( $[NB]_0 = [O_3]_0 = C$ ). It established that kinetic curves of consumption of initial reagents are linearized in second order equation:

$$1/C = 1/C_0 + k t \quad (r \geq 0.995),$$

where  $k$  – the rate constants of  $O_3$  reaction with NB. From experiments on a bubbling installation it is found that 1 mol of absorbed ozone is has to 1 mol of consumed nucleic base. Analysis of obtained result showed that reaction of oxidation of nucleic bases by ozone is obeyed the kinetic law of second order:

$$V = k [NB] [O_3].$$

In last stage of study the temperature dependence of second order rate constant  $k$  was explored in range of 285-309 K. Obtained data processing in logarithm coordinates of Arrhenius equation allowed to get the values of pre-exponential factors  $A$  and activation energies  $E$  of oxidation reactions of nucleic bases by ozone in aqueous solutions:

Nucleic bases	Adenine	Thymine	Uracil	Cytosine
$\lg A (l \text{ mol}^{-1} \text{ s}^{-1})$	$11.7 \pm 0.9$	$5.1 \pm 0.5$	$7.2 \pm 0.7$	$10.3 \pm 0.6$
$E, \text{ kJ/ mol}$	$59.3 \pm 4.7$	$23.2 \pm 2.8$	$30.3 \pm 4.2$	$50.3 \pm 3.1$

It should be noted that ozone reaction with nucleic bases in aqueous solutions is accompanied by chemoluminescence in the visible part of spectrum.

## References

- [1] Maksyutova A. A., Zimin Yu. S., Gimadieva A. R., Mustafin A. G. *Russ. J. Phys. Chem. A*. **2019**, 93 (9), 1672-1676.  
[2] Maksyutova A. A., Moiseeva E.D., Zimin Yu. S. *Vestn. BashGU*. **2020**, 25 (2), 302-307.

Acknowledgements. This work was supported by the Russian Science Foundation (project No 19-73-20073).





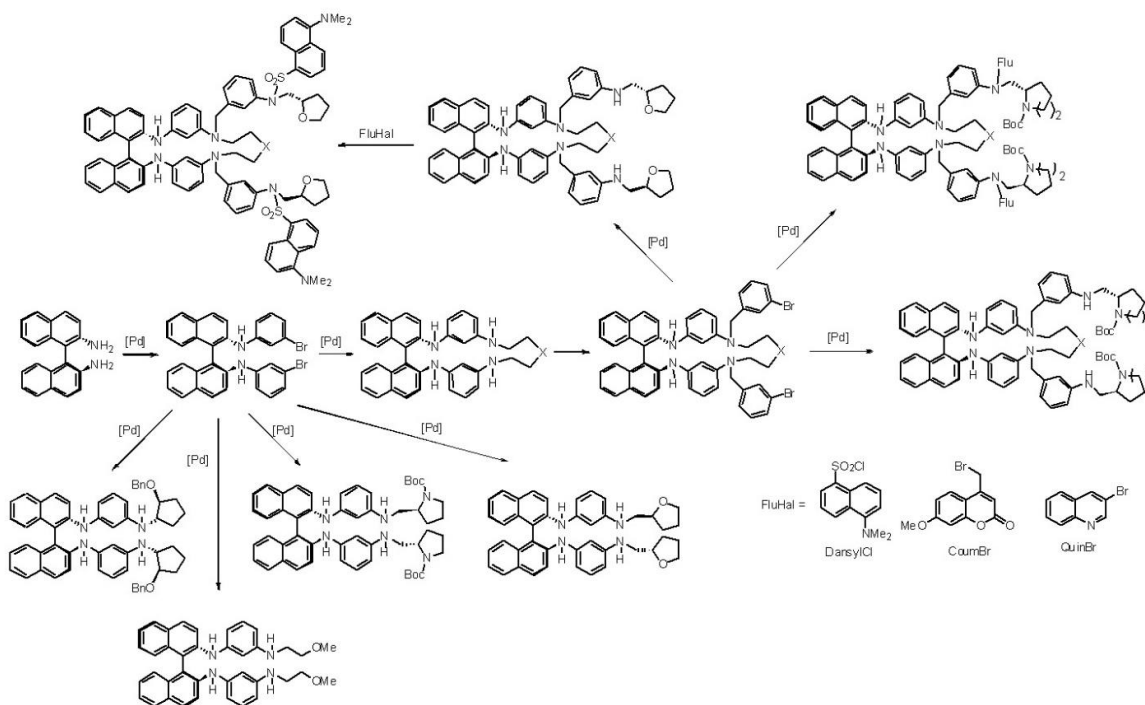
Pd(0)-CATALYZED AMINATION IN THE SYNTHESIS OF FLUORESCENT DETECTORS  
BASED ON 2,2'-DIAMINO-1,1'-BINAPHTHALENE (BINAM)

*Malysheva A.S.<sup>1</sup>, Averin A.D.<sup>1</sup>, Beletskaya I.P.<sup>1</sup>*

<sup>1</sup>Moscow State University, Moscow, Russia  
Postgraduate  
[Annette9513@yandex.ru](mailto:Annette9513@yandex.ru)

Nowadays the identification of individual enantiomers of the bio- and catalytically active compounds is of great significance for both fundamental and applied chemistry. One of the most promising approaches for the enantiomers detection is fluorescence spectroscopy due to its high selectivity and sensitivity as well as the ability to perform an express analysis.

Compounds based on chiral (*S*)-2,2'-diamino-1,1'-binaphthalene (BINAM) were modified with oxadiazine and polyamine linkers by palladium-catalyzed amination. A series of macrocyclic compounds with exocyclic fluorophore groups such as dansyl, 7-methoxycoumarin and quinoline was obtained on their basis. Macrocycles have also been modified with additional chiral substituents [1]. Another series of compounds was obtained by Pd(0)-catalyzed amination of *N,N'*-di(3-bromophenyl) substituted BINAM with a number of chiral amines and decorated with various fluorophores [2]. It has been found that these compounds can be successfully used as fluorescent chemosensors for selective fluorescence detection of a number of model amino alcohols.



**Figure 1.** Modification of the BINAM-containing macrocycles with exocyclic chiral and fluorophore groups

Further development of this approach includes the synthesis and studies of the BINAM derivatives with condensed aromatic moieties and the formation of BINAM-based macrocycles with the porphyrin units as powerful fluorophores.

#### References

- [1] Averin A.D., Grigorova O.K., Malysheva A.S., Shaferov A.V. and Beletskaya I.P. *Pure Appl. Chem.* **2020**, 92(8), 1367-1386
- [2] Shaferov A.V., Malysheva A.S., Averin A.D., Maloshitskaya O.A. and Beletskaya I.P. *Sensors* **2020**, 20, 3234

This work was supported by the Russian Foundation for Basic Research (grant № 18-03-00709)

# EFFECTIVE SYNTHESIS OF TETRAETHYL ETHYLENE-1,1,2,2-TETRACARBOXYLATE

*Martyanov G.S.*<sup>1,2</sup>, *Barabanov M.A.*<sup>1</sup>, *Pestov A.V.*<sup>1,2</sup>

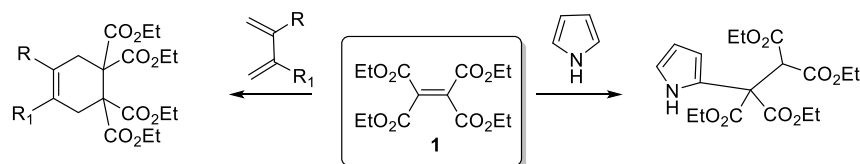
<sup>1</sup>I.Ya. Postovsky Institute of Organic Synthesis RAS, Ekaterinburg, Russia

<sup>2</sup>Ural State University, Ekaterinburg, Russia

Student

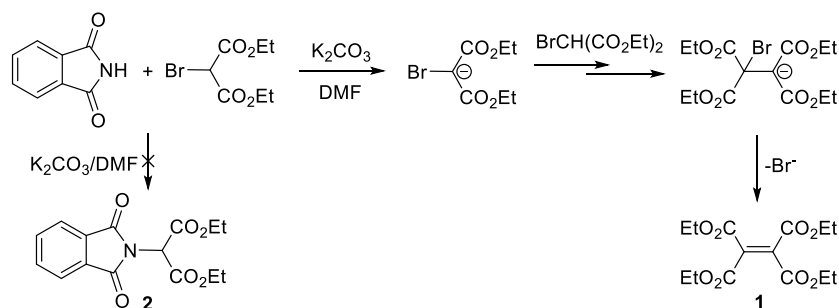
[flimsey@mail.ru](mailto:flimsey@mail.ru)

Tetraethyl ethylene-1,1,2,2-tetracarboxylate (tetraester) **1** is a valuable synthon for miscellaneous reactions, including cycloaddition reactions. It can be used for synthesis of functionalized 4- or 6-membered rings [1]. In addition, it can act as an electrophile [2].



**Figure 1.** Reactions of tetraester **1**

We obtained tetraester **1** instead of the target phthalimidomalonic ester **2** by alkylation of phthalimide with bromomalonic ester in the presence of anhydrous potassium carbonate in DMF. This result can be explained as follows. Potassium phthalimide, which is obtained *in situ*, being a bulky nucleophile, acts as a base and deprotonate the molecule of CH-acidic bromomalonic ester. Then, so obtained anion is alkylated by second molecule of bromomalonic ester followed by elimination of bromide ion by a base.



**Figure 2.** Synthesis of tetraester **1**

It should be noted that quantitative yield of tetraester **1** was not previously achieved in the absence of phthalimide. For example, tetraester **1** can be prepared by action of sodium hydroxide on bromomalonic ester only in 86% yield [3].

The target compound **1** can be obtained by mixing of bromomalonic ester, phthalimide, excess of potassium carbonate in DMF with subsequent quenching with cold aqueous acetic acid. The precipitate should be filtered, washed with water, dried and recrystallized from hexane. Tetraester **1** is obtained as colorless crystals, m.p. 55-56 °C, yield is quantitative.

A simple and effective method for the synthesis of tetraethyl ethylene-1,1,2,2-tetracarboxylate has been developed.

## References

- [1] Mlynek C., Hopf H., Yang J., Laane J. *J. Molecular Structure* **2005**, *742*, 161-164.
- [2] Asahara H., Kawakami S., Yoshioka K., Tani S., Umezumi K., Nishiwaki N. *Bull. Chem. Soc. Japan* **2018**, *91*, 1715-1723.
- [3] Peng R.-F., Wang G.-W., Shen Y.-B., Li Y.-J., Zhang T.-H., Liu Y.-C., Murata Y., Komatsu K. *Syn. Commun.* **2004**, *34*, 2117-2126.

# ELECTROCATALYTIC APPROACH TO SPIRO[FURO[3,2-*b*]PYRAN-2,5'-PYRIMIDINES]

Maslov O.I.<sup>1</sup> Ryzhkova Y.E.<sup>2</sup> Elinson M.N.<sup>2</sup>

<sup>1</sup>D.I. Mendeleev University of Chemical Technology of Russia, Moscow, Russia

<sup>2</sup>N.D. Zelinsky Institute of Organic Chemistry, Moscow, Russia

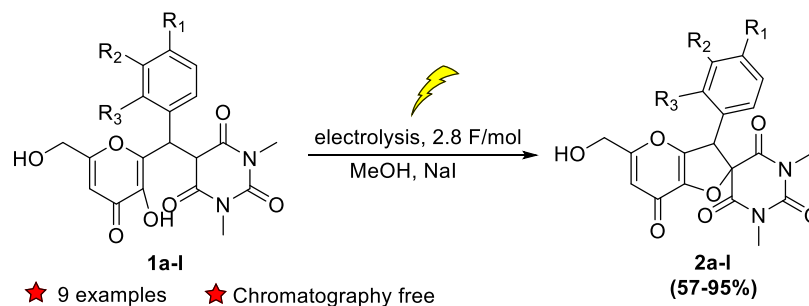
Student

[mo100@yandex.ru](mailto:mo100@yandex.ru)

Electrochemical reactions are an important method to carry out effective organic synthesis, corresponding to the concept of «green chemistry» [1-2]. This approach has unique advantages: use of electrons as redox reagents, reactions can be adjusted by the applications of potential and current and to achieve a high selectivity of the reaction, which is not available in traditional methods [3].

Barbituric acid derivatives are often used as anesthetic, anticonvulsant [4] and antitumor drugs [5]. Spirobarbiturates also have various beneficial pharmacological and physiological activities. For example, spiro[pyrrol-barbiturates] are known as inhibitors of matrix metalloproteinase 13 (MMP-13) and can be applied in osteoarthritis and rheumatoid arthritis therapy [6]. Kojic acid derivatives exhibit antibacterial [7], anti-inflammatory and anticonvulsant activity [8].

In this study, we report our results in the selective and efficient cascade electrocatalytic cyclization of substituted (*4H*-pyran-2-yl(aryl)methyl)-1,3-dimethylpyrimidines **1** into previously unknown spiro[furo[3,2-*b*]pyran-2,5'-pyrimidines] **2** in an undivided cell after 2.8 F/mol of electricity passed (Scheme 1). The reactions were carried out in methanol in the presence of sodium iodide as mediator.



**Scheme 1.** Electrochemical cyclization of the substituted (*4H*-pyran-2-yl(aryl)methyl)-1,3-dimethylpyrimidines

Thus, electrochemical cyclization of various substituted (*4H*-pyran-2-yl(aryl)methyl)-1,3-dimethylpyrimidines **1** results in various functionalized spiro[furo[3,2-*b*]pyran-2,5'-pyrimidines] **2** with modest or excellent yields (57-95%). This efficient procedure utilizes not complex equipment, available and cheap mediator – sodium iodide, it is easily carried out and the isolation procedure is simple. This method is valuable from the viewpoint of environmentally benign diversity-oriented large-scale processes.

## References

- [1] Yan M., Kawamata Y., Baran P.S. *Chem. Rev.* **2017**, *117*, 13230–13319
- [2] Meyer T.H., Finger L.H., Gandeepan P., Ackermann L. *Trends Analyt. Chem.* **2019**, *1*, 63–76
- [3] Li H., Xue, Y., Ge Q. Liu M., Cong H. Tao Z. *Molecular Catalysis.* **2020**, *499*, 111296
- [4] Johns M. W. *Drugs.* **1975**, *9*, 448–478
- [5] Maquoi E., Sounni N.E., Devy L., Olivier F., Frankenne F., Krell H.W., Grams F., Foidart J.M., Noel A. *Clin. Cancer Res.* **2004**, *10*, 4038–4047.
- [6] Kim S., Pudzianowski A. T., Leavitt K. J., Barbosa J., McDonnell P. A., Metzler W.J., Rankin B. M., Liu R., Vaccaro W., Pitts W. *Bioorg. Med. Chem. Lett.*, **2005**, *15*, 1101
- [7] Reddy B.V., Reddy M.R., Madan C., Kumar K.P., Rao M.S. *Bioorg. Med. Chem. Lett.* **2010**, *20*, 7507–7511
- [8] Aytemir M.D., Özçelik B. *Eur. J. Med. Chem.* **2010**, *45*, 4089–4095

Acknowledgements. This work was supported by the Russian Foundation for Basic Research (Project No. 19-29-08013).

# NOVEL ORANGE FLUORESCENT CYANO-SUBSTITUTED 2,2'-BIPYRIDINE DERIVATIVES

*Mayorov N.S. Ievlev M. Yu*

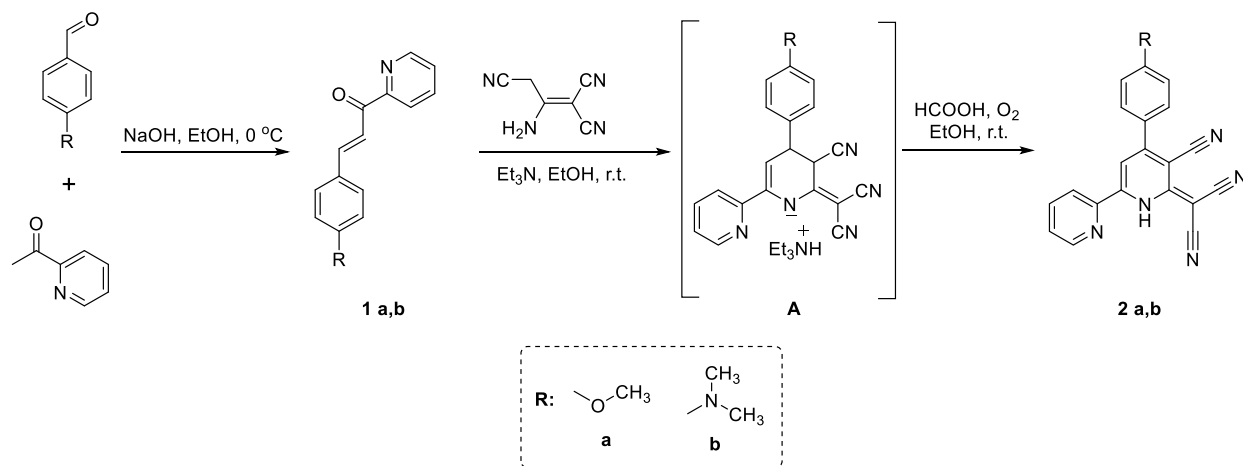
FSBEI HE "Chuvash State University named after I.N. Ulyanov", Cheboksary, Russia

Student

mayorov.n.s@gmail.com

For the last several years, the synthesis and characterization of heterocyclic compounds containing a cyano-containing bipyridine core in their structure have acquired a great importance. This is due to the fact that these derivatives have a wide application range in various fields of modern science. 2,2'-Bipyridine derivatives are well known and described as a good chelating compounds[1]. Due to the tendency to further functionalization and the presence of reaction centers, fine-tuning of the receptor part is possible. Cyano-substituted 2,2'-bipyridine derivatives are not so well studied. In this regard, we decided to synthesize novel bipyridine derivatives containing butadiene-1,1,3,3-tricarbonitrile fragment, which was shown as promising moiety to impart useful characteristics to the substance.

Basing on the retrosynthetic analysis and experimental data, the following synthetic pathway was proposed (Figure 1), which consists in nucleophilic addition of malononitrile dimer to unsaturated ketone **1**, followed by intramolecular heterocyclization in the presence of a base. We found that the reaction can be carried out in one-step without isolation of the intermediate **A**. The starting  $\alpha, \beta$ -unsaturated ketone **1** was obtained by the interaction of 2-acetylpyridine and corresponding aldehydes in an alkaline medium.



**Figure 1.** Synthesis of cyano-substituted bipyridine derivatives **2**

The structures of the obtained cyano-substituted bipyridine derivatives **2** were supported by IR-, NMR-spectroscopy and mass-spectrometry. Compounds **2** are stable, bright orange crystalline substances dissolving in polar organic solvents and showing fluorescence in the yellow-orange region of the spectrum (565-574 nm). It was noted that the replacement of the methoxy group by the dimethylamino fragment result in a significant increase of the emission intensity. The 2,2'-bipyridine framework, as well as the luminescent properties of compounds **2**, make them promising candidate for studying of chemosensory properties regarding to various practically significant ions, and the simplicity and efficiency of the developed approach demonstrates its high synthetic potential.

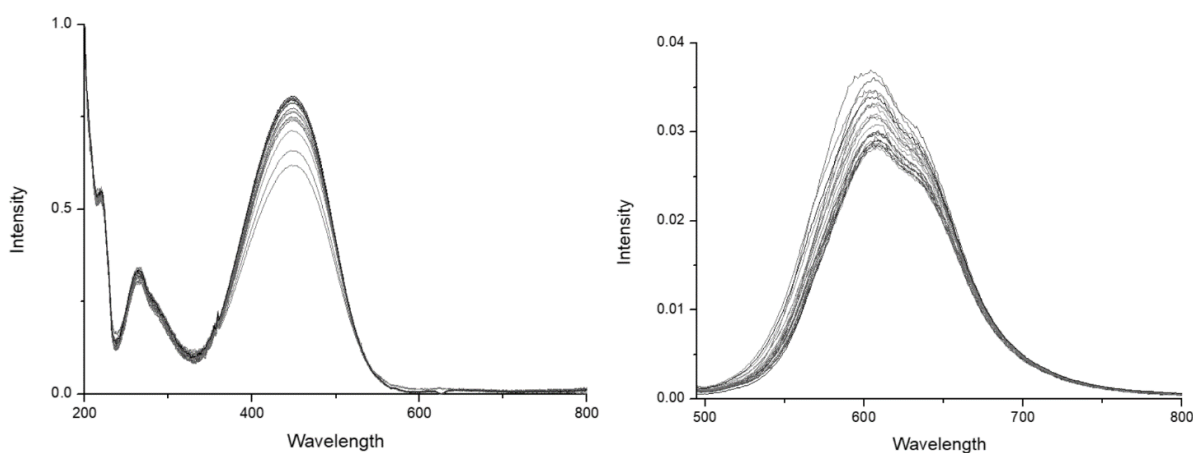
## References

[1] C. Kaes, A. Katz, M.W. Hosseini, *Chemical Reviews* **2000**, *100*, 3553–3590

Acknowledgements. The study was carried out within the framework of the grant of the President of the Russian Federation for state support of young Russian scientists MK-708.2021.1.3, agreement No. 075-15-2021-082.

Styryl dyes are an interesting object in the chemistry of guest-host complexes [1]. The presence of a chromophore system makes it possible to study such dyes both by NMR methods and by electron and fluorescence spectroscopy. The planarity of the (*E*)-isomer of the dye molecule allows the formation of inclusion complexes with cavitands through non-covalent interactions. Styryl dyes are components of supramolecular assemblers [2] and are part of materials [3].

It is known that the DAST dye (4- [4- (dimethylamino) styryl] -N-methylpyridinium tosylate) exhibits nonlinear optical properties. We synthesized this dye with a good yield (61%), and also studied its complexation (figure 1) with alpha, beta-cyclodextrins (CDs) and cucurbit[7]uril (CB7).



**Figure 1.** Absorption (a) and emission (b) spectra of DAST with addition of cavitand cucurbit[7]uril in water.

It was found that DAST forms complexes of various stoichiometry and composition with the described cavitands. Thus, in the case of CB7, a 1 : 1 complex is formed, while with a beta-CD cavity comparable in volume, a 1 : 2 complex is formed. The data obtained can be used as a control element for the supramolecular system.

### References

- [1] Ushakov E.N., Vedernikov A.I., Lobova N.A., Dmitrieva S.N., Kuz'mina L.G., Moiseeva A.A., Howard J.A.K., Alfimov M.V., Gromov S.P., *Journal of Phys. Chem. A*, **2015**, 119 (52), 13025–13037.
- [2] Gromov S. P., Vedernikov A. I., Kuz'mina L. G., Kondratuk D. V., Sazonov S. K., Strelenko Y. A., Alfimov M. V., Howard J. A. K., *Eur. J. Org. Chem*, **2010**, 13, 2587–2599.
- [3] Koshkin, A. V., Aleksandrova, N. A., & Ivanov, D. A. *Journal of Sol-Gel Science and Technology* **2017**, 81(1), 303-310.

INVESTIGATION OF METAL-PROMOTED REACTION OF NUCLEOPHILIC ADDITION OF N-ALKYNYLATED AMINES TO BIS-ISOCYANIDE COMPLEXES OF PALLADIUM (II) AND PLATINUM (II) AS A METHOD FOR SYNTHESIS OF ALKYNYLATED ACYCLIC DIAMINOCARBENE COMPLEXES

Melnik M.V.<sup>1</sup>, Mikhaylov V.N.<sup>1</sup>

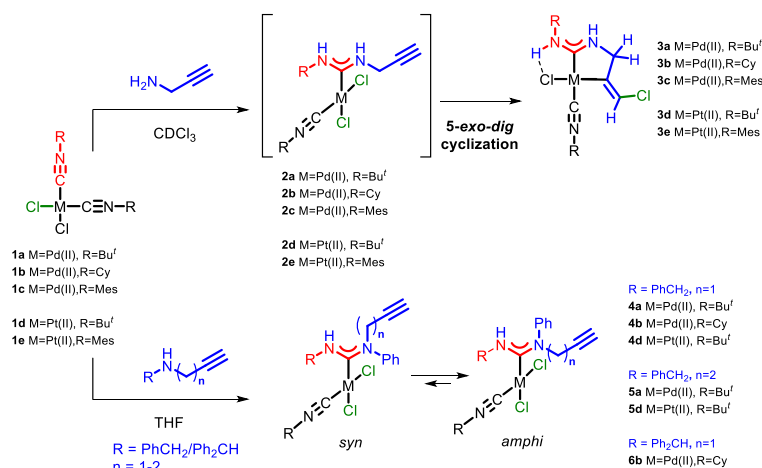
<sup>1</sup>Saint Petersburg State University, Saint Petersburg, Russia

Student

[melnikmaria-0708@mail.ru](mailto:melnikmaria-0708@mail.ru)

Carbene complexes of Pd(II) and Pt(II) are widely used in various fields, from catalysis to biomedicine. The insertion of a triple bond into the structure of carbene ligand provides an opportunity to study the interactions between triple bond and metal center, as well as possibility of the complexes subsequent modification in order to increase the selectivity of their antitumor activity [1]. Alkynylated acyclic diaminocarbene (ADC) complexes due to the structural features of ADC ligand [2] may be of particular interest both to study interactions and for biomedical applications.

In this work, we studied the possibilities and limitations of the synthesis of new N-alkynylated ADC complexes of Pd(II) and Pt(II) by a metal-promoted nucleophilic addition of N-alkynylated amines to corresponding *bis*-isocyanide complexes of Pd(II) and Pt(II) (Fig. 1).



**Figure 1.** The result of a metal-promoted reaction of the addition of primary and secondary N-alkynylated amines to *bis*-isocyanide complexes of Pd(II) and Pt(II).

It has been shown that it is impossible to obtain target complexes **2a-e** with primary propargylamine, since they are extremely unstable with respect to a previously unknown process of intramolecular regioselective chlorometallation. *5-Exo-dig* cyclization products **3a-e** were first identified. The structural details of **3e** were confirmed using X-ray analysis. It is noteworthy that Et<sub>4</sub>N<sup>+</sup>Cl<sup>-</sup> as an external source of chloride ions stabilized complex **2a** under same conditions.

To our surprise, in the reaction with secondary amines (N-propargylbenzylamine, N-propargylbenzhydrylamine, N-but-3-ynylbenzylamine), it was possible to obtain the target ADC complexes **4a-d**, **5a**, **5d**, **6b** containing triple bond in their structure. The resulting complexes exist in solution as a mixture of *syn* and *amphi* conformers, the ratio of which depends on the nature of the substituents. Despite the stability in the solid phase, complexes **4b** and **6b** in solution transform over time into products of intramolecular *5-exo-dig* cyclization.

As a result, the possibility of N-alkynylated ADC complexes obtainment through the reaction with secondary N-alkynylated amines was shown, and a new intramolecular *5-exo-dig* cyclization process destabilizing the triple bond in the complexes structure was discovered.

## References

- [1] Chardon E. et al. *Inorganica Chim. Acta* **2017**, *467*, 33-38  
[2] Slaughter LGM. *ACS Catal.* **2012**, *2*, 1802-1816

Acknowledgements. This work was supported by the Russian Science Foundation (project No 21-73-00170). The work was performed by equipment of SPbU Research Park: RC MRR, RC XRD, RC CAMR.

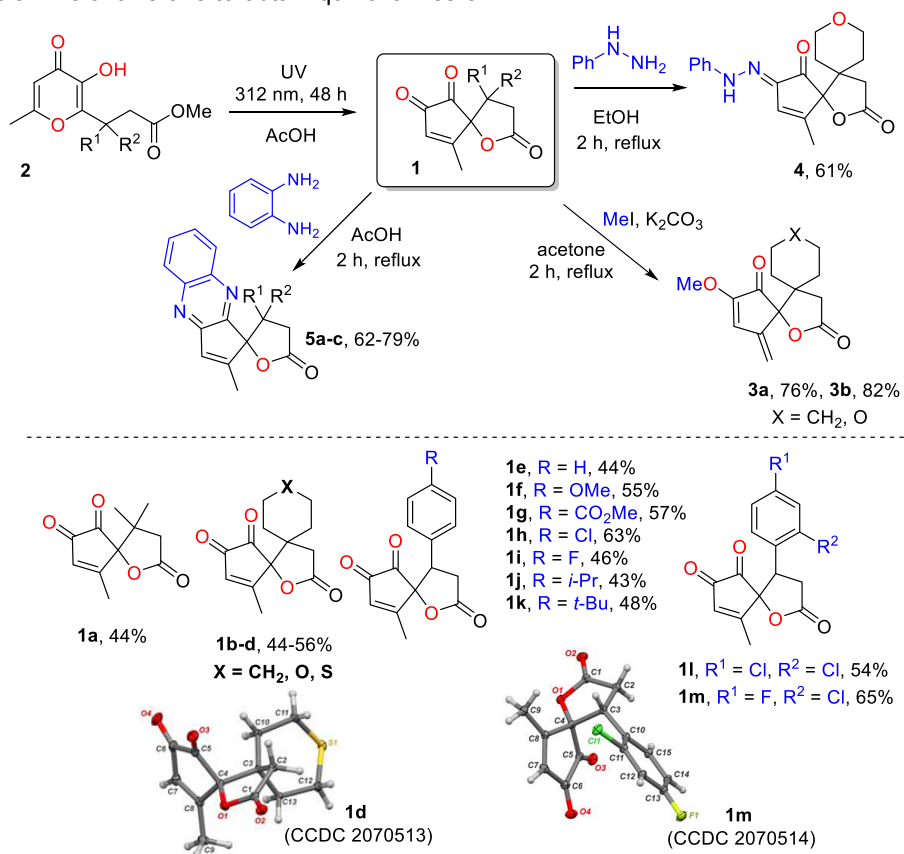
# CONSTRUCTION OF SPIRO- $\gamma$ -BUTYROLACTONE CORE VIA CASCADE PHOTOCHEMICAL REACTION OF 3-HYDROXYPYRAN-4-ONE DERIVATIVES

Milyutin C.V.<sup>1</sup>, Komogortsev A.N.<sup>1</sup>, Lichitsky B.V.<sup>1</sup>, Melekhina V.G.<sup>1</sup>, Minyaev M.E.<sup>1</sup>

<sup>1</sup> N. D. Zelinsky Institute of Organic Chemistry, Russian Academy of Science, Moscow, Russian  
[kostil4595@gmail.com](mailto:kostil4595@gmail.com)

In recent years, photochemical processes are attracting increasing attention of researchers due to the wide use in various fields of organic chemistry. An important area of photochemistry is the study of the behavior of heterocyclic compounds under UV irradiation.<sup>1-2</sup> Among the vast variety of heterocyclic systems, phototransformations of 4-pyranone derivatives attract considerable attention.

In present study we elaborated novel one-step photochemical method for the synthesis of spiro- $\gamma$ -butyrolactone **1** derivatives from 3-hydroxypyran-4-ones **2**. The suggested approach based on cascade process including initial photoinduced contraction of 4-pyranone ring followed by intramolecular cyclization leading to the final spiro-system **1**. A distinctive feature of the proposed method is intramolecular trapping of unstable  $\alpha$ -hydroxydiketone intermediate formed *in situ* as a result of a photochemical reaction. The structures of two synthesized 1-oxaspiro[4.4]non-8-ene-2,6,7-triones were determined by X-Ray diffraction. The synthetic utility of the prepared compounds was demonstrated by further derivatization of photoproducts **1**. Thus, alkylation by methyl iodide in the presence of K<sub>2</sub>CO<sub>3</sub> led to methylated enols **3a** and **3b**. At the same time, monohydrazone **4** was obtained based on interaction with phenylhydrazine. It should be mentioned that the  $\alpha$ -diketone fragment in lactones **2** can be used to construct heterocyclic systems. For example, the condensation of compounds **1** with 1,2-phenylenediamine allows one to obtain quinoxalines **5**.



**Figure 1.** Formation and further derivatization of **1**.

## References

- [1] Ralph, M. *Curr. Org. Chem.* **2011**, *15*, 2658–2672  
 [2] Lefebvre. C., Fortier, L., Hoffmann, N. *Eur. J. Org. Chem.* **2020**, *2020*, 1393–1404

Acknowledgements. This work was supported by the Russian Science Foundation (Project № 18-13-00308-P).



*Mironova I.A.*<sup>1,2</sup> *Kirsch S.F.*<sup>2</sup>, *Yusubov M.S.*<sup>1</sup>, *Zhdankin V.V.*<sup>1,3</sup>

<sup>1</sup>Tomsk Polytechnic University, Tomsk, Russia

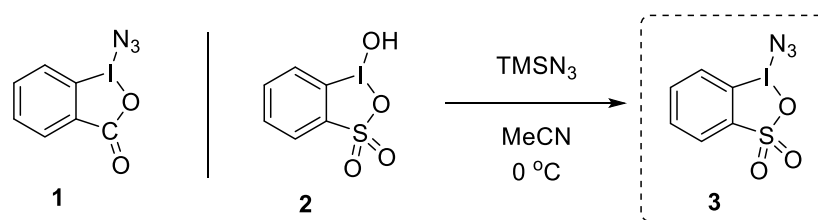
<sup>2</sup>Bergische Universität Wuppertal, Wuppertal, Germany

<sup>3</sup>University of Minnesota, Duluth, USA

[iam6@tpu.ru](mailto:iam6@tpu.ru)

Hypervalent iodine compounds are highly applicable reagents in organic synthesis attracting increasing attention in the fields of medicine and material science [1-3]. First representatives of N<sub>3</sub>-transfer hypervalent iodine reagents were synthesized and investigated by Zhdankin in 1990s [4-5]; however, their synthetic utilities were significantly broadened only 20 years later [6-9]. Zhdankin's reagent **1** and its derivatives were efficiently utilized for C(sp<sup>3</sup>)-H functionalization of diverse organic substrates including natural products, but they still have serious disadvantages due to explosive properties at heating and physical impact. Therefore, development of useful and safe transfer reagents, e.g. azidating reagents, is extremely relevant.

We have designed a new azidating reagent – the thia-analogue of well-known Zhdankin's reagent – which possesses high reactivity at mild reaction conditions and is safer for handling.



**Figure 1.** New safe and highly reactive azidating reagent based on hypervalent iodine

The structure of prepared reagent **3** was investigated using X-ray analysis, and it was shown that the reagent has cyclic form with quite long, almost ionic, I-O-bond that increases electrophilicity of iodine center.

The stability of the compounds was then determined by differential scanning calorimetry. The DSC results revealed a heat release of our reagent is significantly less in comparison with the original Zhdankin's reagent **1** [9]. The onset temperature of reagent **3** also was higher than the ones for other azidating reagents, consequently, reagent **3** is safer azidoiodinane than the earlier derivatives.

The reactivity of synthesized compound **3** was investigated in the reactions with ketones. Products of these reactions are highly energetic  $\alpha$ -polyazidated ketones, which can be used for a broad range of transformation, for instance, amination, "click-chemistry" etc.

#### References

- [1] Olofsson B., Marek I., Rappoport Z. *The Chemistry of Hypervalent Halogen Compounds*. John Wiley & Sons, **2019**;
- [2] Zhdankin V. V. *Hypervalent iodine chemistry: preparation, structure, and synthetic applications of polyvalent iodine compounds*. John Wiley & Sons, **2013**;
- [3] Yoshimura A., Zhdankin V. V. *Chem. Rev.* **2016**, 116, 5, 3328;
- [4] Zhdankin V. V. et al. *Tetrahed. Lett.* **1994**, 35, 52, 9677;
- [5] Zhdankin V. V. et al. *J. Am. Chem. Soc.* **1996**, 118, 5192
- [6] Sharma A., Hartwig J.F., *Nature*. **2015**, 517, 600;
- [7] Saito A. et al. *Org. Lett.* **2015**, 17, 5212;
- [8] Hartwig J. F. et al. *Angew. Chem. Int. Ed.* **2021**, 60, 8276;
- [9] Waser J. et al. *J. Org. Chem.* **2018**, 83, 12334.

**Acknowledgements.** This work was supported by the Ministry of science and high education of the Russian Federation and DAAD foundation within the framework of the Russian-German academic exchange program "Michael Lomonosov Program Linie A" and the Russian Science Foundation (project No 21-73-20031).

# N-IODOSUCCINIMIDE-MEDIATED DIMERIZATION OF INDODICARBOCYANINE DYES

*Mitroshin A.M.*<sup>1</sup>, *Miltsov S.A.*<sup>2</sup>

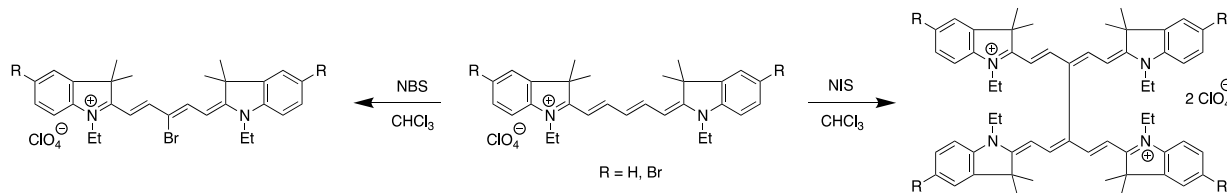
<sup>1</sup> Saint-Petersburg State Institute of Technology, Saint-Petersburg, Russia

<sup>2</sup>Institute of Macromolecular Compounds, Saint-Petersburg, Russia

Student

[almitroshin51@gmail.com](mailto:almitroshin51@gmail.com)

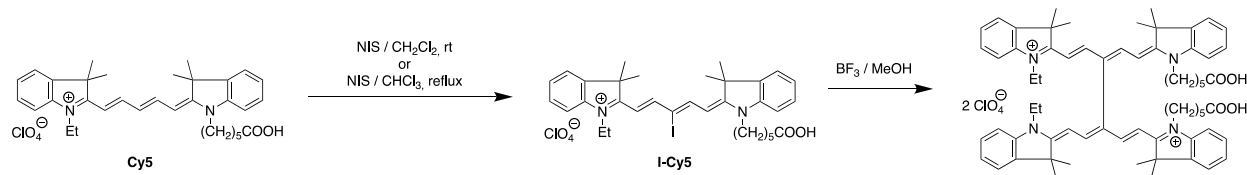
In the course of our research in chemistry of cyanine dyes, it was found that indodicarbocyanines with powerful electron-donating substituents (-NHCOCH<sub>3</sub>, -OH) in the benzene rings reacted with *N*-bromosuccinimide (NBS) giving dimeric products [1]. It appeared that the analogous reaction with *N*-iodosuccinimide (NIS) was less sensitive to aryl ring substituents making possible to expand the circle of dyes that could be involved in the dimerization process.



**Figure 1.** Reaction of NIS and NBS with indodicarbocyanine dyes.

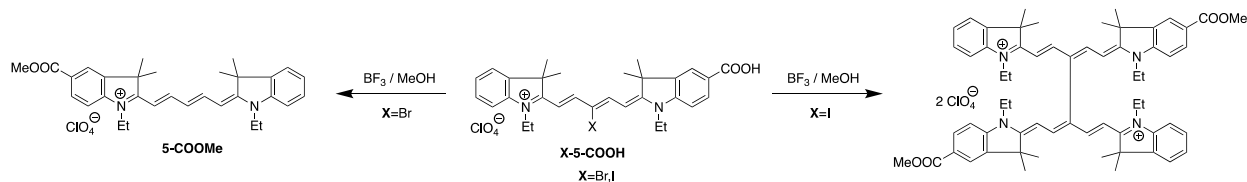
In case R = H the dimeric dye was a sole product while with mono- and dibrominated cyanines the reaction at room temperature furnished mixtures of comparable amounts of dimers and *meso*-iodinated species. When the process was conducted at elevated temperature (refluxing in chloroform) pure dimeric cyanines were obtained.

Moreover, we have recognized that dimerization process is sensitive to steric hindrance. In case of indodicarbocyanines with bulky *N*-substituents (**Cy5** for example) only formation of the *meso*-iodinated dye was observed. Nevertheless, dimeric **Cy5** was obtained from **I-Cy5** by previously described reaction with BF<sub>3</sub> in methanol [2].



**Figure 2.** Dimerization of indodicarbocyanine dye with bulky *N*-substituent.

*meso*-Iodinated dyes appeared more reactive in the BF<sub>3</sub>-catalyzed dimerization process than brominated analogues. So, we managed to obtain the dimeric dye from *meso*-I-5-COOH-substituted cyanine while the brominated dye gave only the hydrodebrominated product.



**Figure 3.** Reaction of **5-COOH** halogenated cyanine with BF<sub>3</sub> in MeOH.

## References

[1] S. Miltsov, M. Goikhman, A. Yakimansky A. Misharev, M. Puyol, J. Alonso. *Tetrahedron Letters* **2019**, *60*, 151005

[2] S. Miltsov, V. Karavan, A. Misharev, G. Starova, J. Alonso, M. Puyol. *Tetrahedron Letters* **2017**, *58*, 3353–3357

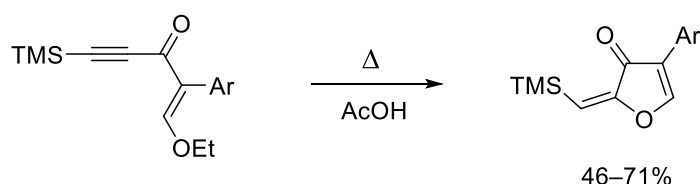
## SYNTHESIS OF FURANONES FROM ALKENYNONES

*Molin I.A.<sup>1</sup>, Pankova A.S.<sup>1</sup>, Golubev P.R.<sup>1</sup>*

<sup>1</sup>Saint Petersburg State University, Saint Petersburg, Russia  
Student  
[molin96@yandex.ru](mailto:molin96@yandex.ru)

Cross-conjugated alkenynones, namely 1-ethoxy-5-trimethylsilylpent-1-en-4-yn-3-ones, represent a polyelectrophilic scaffold with a great potential in heterocyclic synthesis. Their reactivity towards mono- and binucleophiles was thoroughly studied, and these compounds were employed as building blocks in the syntheses of nitrogen-containing five- and six-membered heterocycles: pyrazoles, pyrimidines, pyrrolones and pyrazolo[1,5-a]pyrimidines [1-4]. However, in the absence of nucleophiles a cyclization into furan derivative can occur and serve as a novel approach to this skeleton.

Alkenynones can be converted into 2-(trimethylsilylmethylidene)furan-3-ones by heating in acetic acid. The reaction tolerates various substituents in aryl fragment, *i.e.* electron-withdrawing and donating groups in *para*- or *ortho*-position of the phenyl ring.



**Figure 1.** Cyclization of alkenynones into furanones

The final heterocycles are a type of furan derivatives previously unknown in the literature. Further work dealing with physical properties and reactivity of these compounds is under progress in our group.

### References

- [1] A.S. Pankova, P.R. Golubev, I.V. Ananyev, M.A. Kuznetsov *Eur. J. Org. Chem.* **2012**, 5965–5971
- [2] P.R. Golubev, A.S. Pankova, M.A. Kuznetsov *Eur. J. Org. Chem.* **2014**, 3614–3621
- [3] P.R. Golubev, A.S. Pankova, M.A. Kuznetsov *J. Org. Chem.* **2015**, *80*, 4545–4552
- [4] P. Golubev, E. A. Karpova, A.S. Pankova, M. Sorokina, M.A. Kuznetsov *J. Org. Chem.* **2016**, *81*, 11268–11275

Acknowledgements: NMR and MS analyses were performed at the Research park of St. Petersburg State University «Center for Magnetic Resonance» and «Center for Chemical Analysis and Materials Research».

# NOVEL DIRECT FUNCTIONALIZATION AND PHOTOCHEMICAL REACTION OF ISOXAZOLES

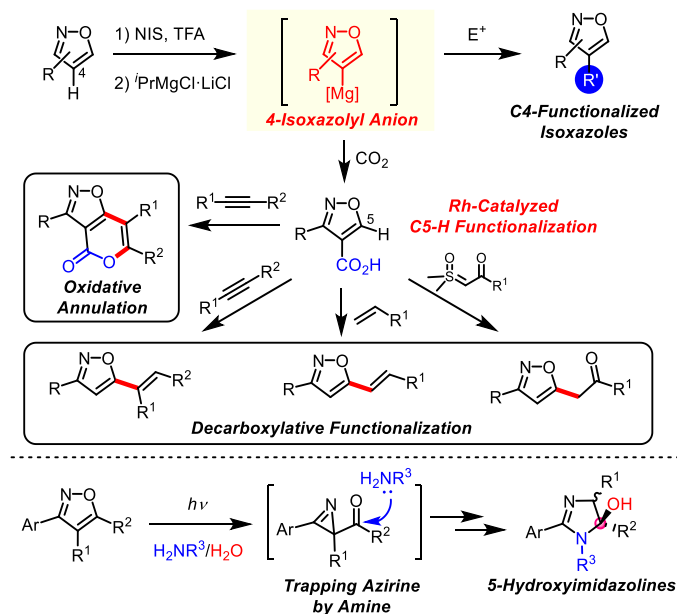
*Morita T., Yugandar S., Nakamura H.*

Laboratory for Chemistry and Life Science, Tokyo Institute of Technology, Yokohama, Japan  
 Assistant Professor  
[t.morita@res.titech.ac.jp](mailto:t.morita@res.titech.ac.jp)

**Introduction:** Isoxazole, a five-membered heterocycle having N-O bond in their ring, has been recognized as a privileged framework in pharmaceuticals. Encouraged by their high utility, various synthetic approaches towards functionalized isoxazoles have been reported. Most of them, however, are based on conventional ring construction strategies that often suffers from insufficient regioselectivity and poor availability of linear components. In sharp contrast, direct functionalization approaches have not been established mainly due to their lability under basic conditions. Besides, although it is known that isoxazoles undergo photolysis to generate highly reactive intermediates, they have scarcely been used in organic synthesis. Given these backgrounds, we studied direct functionalization and photochemical reaction of isoxazoles.

**Methods and Results:** We first examined the generation of 4-isoxazolyl anion species. After iodination of unsubstituted isoxazole, iodine-metal exchange reaction was investigated in detail. As a result, we succeeded in the generation of 4-isoxazolyl anion species by using turbo Grignard reagent under diluted conditions [1]. The carbanion reacted with various electrophiles to produce a wide variety of C4-functionalized isoxazoles, including 4-isoxazolyl carboxylic acids. This carboxylic acid was used for further studies on direct functionalization. In other words, we next examined rhodium-catalyzed carboxylate-directed C-H functionalization at the C5 position. Alkynes were coupled via oxidative annulation to afford bicyclic isoxazoles. Interestingly, under acidic conditions, 4-isoxazolyl carboxylic acids underwent decarboxylative hydroarylation to provide trisubstituted alkenes. This decarboxylative functionalization was successfully expanded to oxidative alkenylation, and acylmethylation. Furthermore, investigation on photochemical reaction of isoxazoles led us to synthesize 5-hydroxyimidazolines via trapping of photogenerated azirines with amines under UV irradiation.

**Conclusions:** We successfully demonstrated direct functionalization approaches towards novel isoxazole derivatives that are not readily available by other means. In addition, unique photochemical reaction of isoxazoles was discovered by nucleophilic addition of amines to photogenerated azirines.



**Figure 1.** Overview of our research on isoxazole chemistry.

## References

- [1] T. Morita, S. Fuse, H. Nakamura, *Angew. Chem. Int. Ed.* **2016**, *55*, 13580–13584.
- [2] S. Yugandar, H. Nakamura, *Chem. Commun.* **2019**, *55*, 8382–8385.
- [3] S. Yugandar, T. Morita, H. Nakamura, *Org. Biomol. Chem.* **2020**, *18*, 8625–8628.
- [4] T. Morita, S. Fuse, H. Nakamura, *Org. Lett.* **2020**, *22*, 3460–3463.

**Acknowledgements.** This work was partially supported by a Grant-in-Aid for Research Activity Start-up (20K22522) and a Grant-in-Aid for JSPS Fellows (17J02929) from the Japan Society for the Promotion of Science (JSPS).

# 4-CHLORO-2-OXOBUT-3-YNOYL CHLORIDE: SYNTHESIS AND CATALYST-FREE [2+2] CYCLOADDITION

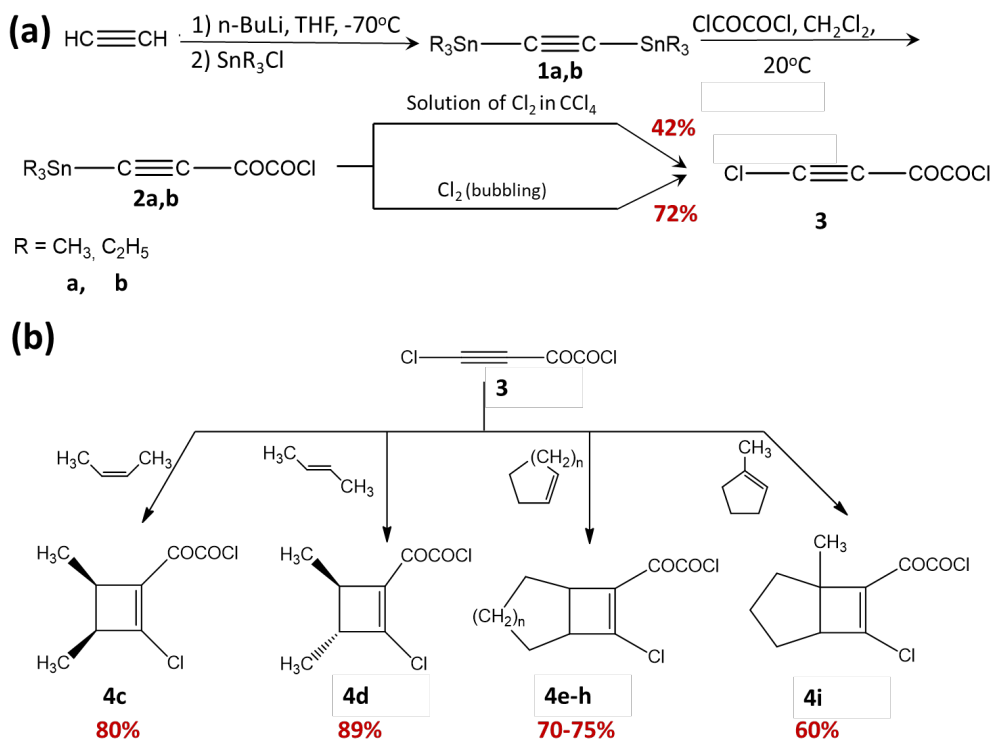
Morozova S.M.<sup>1,2</sup>, Hvorost T.A.<sup>3</sup>, Chernyshov I.Y.<sup>3</sup>, Shilova O.S.<sup>1</sup>, Moiseev S.K.<sup>1</sup> and Koldobskii A.B.<sup>1,2</sup>

<sup>1</sup> A.N. Nesmeyanov Institute of Organoelement compounds Russian academy of science, Moscow, Russia

<sup>2</sup> Bauman Moscow State Technical University, 105005, Russia, Moscow, 2nd Baumanskaya str., 5/1

<sup>3</sup> SCAMT Institute, ITMO University, Lomonosova st. 9, 191002 Saint Petersburg, Russian Federation  
[sofia.morozova@utoronto.ca](mailto:sofia.morozova@utoronto.ca)

The chemistry of alkynes is one of the most interesting and vigorously growing fields of organic synthesis [1]. Among other acetylenes, the halogenated alkynes are of particular importance owing to their wide range of transformations and hence, high synthetic value [1-3]. Of particular interest in the processes of cycloaddition are haloacetylenes, the second substituent in which has a powerful negative mesomeric effect [2]. This combination of substituents in the acetylene molecule dramatically increases the electrophilicity of the C≡C bond, while a mobile halogen atom opens up wide possibilities for their further functionalization. In this work we report the synthesis of novel 4-chloro-2-oxobut-3-ynoyl chloride (compound 3) and its reaction ability in [2+2] reaction. Chloroalkyne activated with extremely strong electron withdrawing oxalyl chloride substituents were prepared from available bis(triethylstannyl) acetylene and the corresponding acid chloride (Fig. 1a).



**Figure 1.** (a) The scheme of the synthesis of 4-chloro-2-oxobut-3-ynoyl chloride; (b) [2+2] cycloaddition of compound 3 with 1,2 disubstituted alkenes.

The proposed synthesis involves the regeneration of the high-yield SnEt<sub>3</sub>Cl used in the first stage. The high reactivity of Cl-C≡C-COCOCl was shown in anomalous reactions of [2+2]-cycloaddition (Fig. 1b). The electrophilicity of the synthesized alkyne is so great that it reacts at room temperature or weak heating up to 36°C with 1,2-disubstituted alkenes with high yields. The isolated cycloadducts contain several highly active electrophilic centers, which opens up wide possibilities for subsequent transformations.

## References

- [1] Wu, W. & Jiang, H. *Acc. Chem. Res.* **2014**, *47*, 2483–2504.  
 [2] Koldobskii, A. B., Shilova, O. S., Artyushin, O. I., Kagramanov, N. D. & Moiseev, S. K., *J. Fluor. Chem.* **2020**, *231*, 109463.  
 [3] Politanskaya, L. V. et al. *Chem. Rev.* **2019**, *88*, 425–569.

Acknowledgements. This work was supported by Russian science foundation (Project No 21-79-20113).  
NOVEL PUSH-PULL FLUOROPHORES BASED ON POLYFLUOROARYL-MODIFIED 2H-IMIDAZOLES

*Moseev T.D.*<sup>1</sup>, *Varaksin M.V.*<sup>1,2</sup>, *Virlova E.A.*<sup>1</sup>, *Charushin V.N.*<sup>1,2</sup>, *Chupakhin O.N.*<sup>1,2</sup>

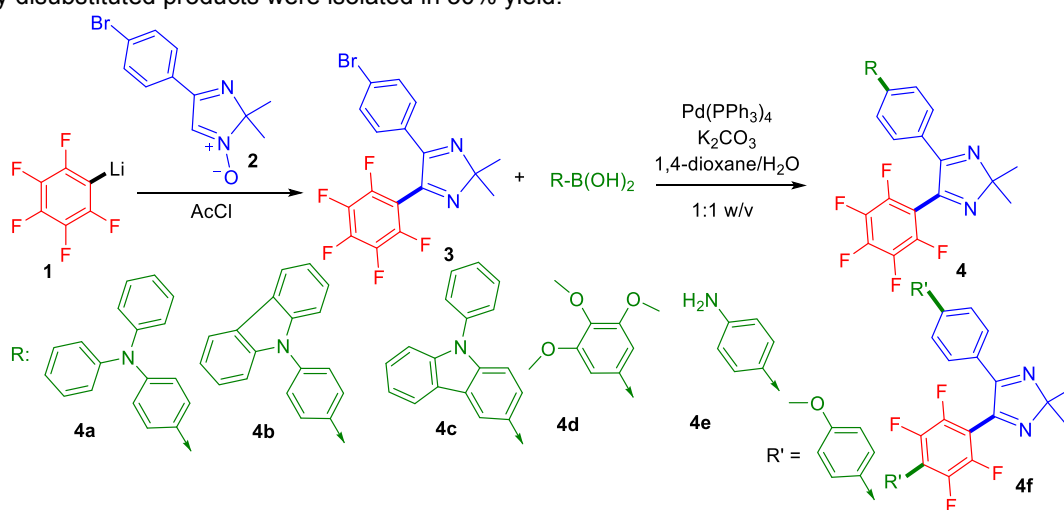
<sup>1</sup>Ural Federal University, 19 Mira Str., 620002 Ekaterinburg, Russia

<sup>2</sup>Institute of Organic Synthesis, Ural Branch of the Russian Academy of Sciences, 22 S. Kovalevskaya Str., 620990 Ekaterinburg, Russia

[m.v.varaksin@urfu.ru](mailto:m.v.varaksin@urfu.ru)

Polyfluorinated arenes are widespread as important building blocks in various biologically active molecules, agrochemicals, and materials for molecular electronics. The electronic effects of the fluorine atom stabilize the HOMO and LUMO energies and thus find their applications in the design of advanced materials, such as semiconductors, FET, OLED, etc.

The synthetic strategy to the target compounds consists of two steps. The first one is based on the reaction of nucleophilic substitution of hydrogen ( $S_NH$ ) in 2*H*-imidazole 1-oxide, where the pentafluorophenyl lithium acts as a nucleophile. The second stage is the Pd-catalyzed Suzuki-Miyaura cross-coupling reaction between the fluorinated imidazole and a boronic acid or the corresponding pinacol ester. The desired compounds were synthesized in 60-85 % yields (over two steps). Notably, in case of *p*-methoxyboronic acid, the only disubstituted products were isolated in 30% yield.



**Figure 1.** Synthesis of push-pull fluorophores based on 2*H*-imidazole

For all synthesized fluorophores, the basic photophysical characteristics (namely, absorbance, emission, absolute quantum yield in different solvents) were studied.

**Table 1.** Photophysical characteristics of fluorophores

	Absorbance in toluene, nm	Emission in toluene, nm	QY in toluene, %	Absorbance in DMSO, nm	Emission in DMSO, nm	QY in DMSO, %
<b>4a</b>	371, 292	446 (br.)	94,53	367, 295	610 (br.)	0,32
<b>4b</b>	341	406 (br.)	44,11	331,293	540 (br.)	14,82
<b>4c</b>	343	407 (br.)	55,30	344, 288	519 (br.)	11,62
<b>4d</b>	318	427 (br.)	81,04	318, 269	351, 552 (br.)	<0,1
<b>4e</b>	340	438 (br.)	3,74	340	472 (br.)	<0,1
<b>4f</b>	315	348, 391 (br.)	62,68	317	403, 526 (br.)	53,72

Thus, a series of novel push-pull fluorophores based on polyfluorinated 2*H*-imidazoles were synthesized, their photophysical properties being investigated. The obtained compounds show emission in range from 400 to 620 nm (depending on the donating group strength) and high values of quantum yields (up to 96%).

### References

[1] Moseev T.D., Varaksin M.V., Gorlov D.A., Charushin V.N., Chupakhin O.N. *Org. Biomol. Chem.*, **2021**, 19, 4429-4459

[2] Moseev T.D., Varaksin M.V., Gorlov D.A., Charushin V.N., Chupakhin O.N. *J. Org. Chem.*, **2020**, 85, 17, 111124-111133

Acknowledgements. This work was supported by the Russian Science Foundation (Project No. 20-73-10077).

# SYNTHESIS OF "PUSH-PULL" FLUOROPHORES BASED ON 2-ARYL(HETERYL)QUINAZOLINES

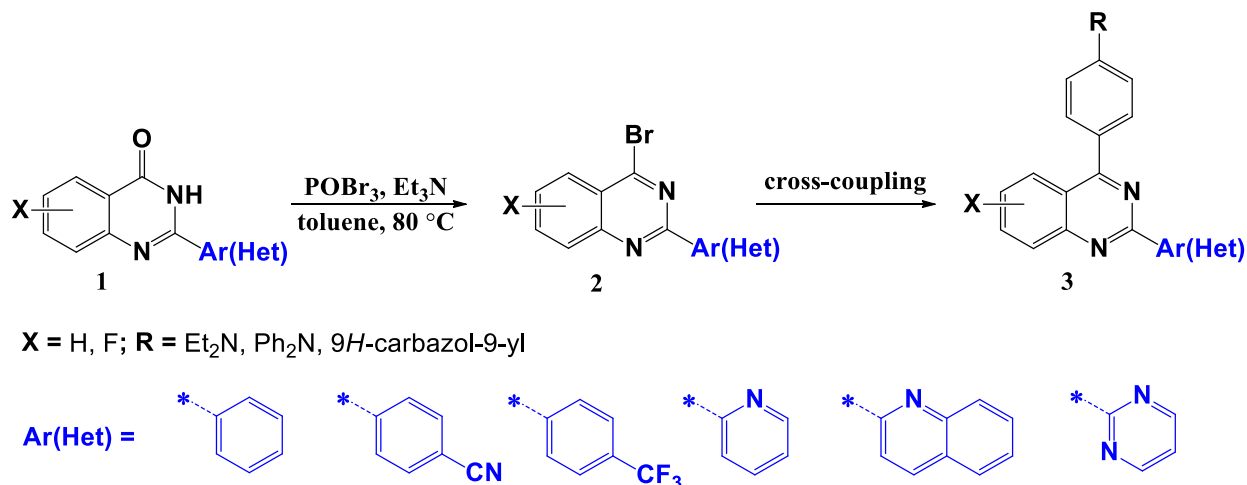
*Moshkina T.N.*<sup>1</sup>, *Kopotilova A.E.*<sup>1</sup>, *Nosova E.V.*<sup>1</sup>,  
*Lipunova G.N.*<sup>1,2</sup>, *Charushin V.N.*<sup>1,2</sup>

<sup>1</sup>Chemical Technology Institute, UrFU, Mira Str. 19, 620002 Yekaterinburg, Russia  
<sup>2</sup>Institute of Organic Synthesis, S. Kovalevskoy Str. 22, 620219 Yekaterinburg, Russia  
\*e-mail: [tan.moshckina@yandex.ru](mailto:tan.moshckina@yandex.ru)

2-Aryl(heteryl)quinazolines represent attractive structures in diverse areas of chemical, biomedical and materials research.[1,2] The possibility of protonation, complexation, and the formation of hydrogen bonds as well as structural variety opens additional opportunity for perspective application of quinazolines as optical materials. Moreover, quinazoline framework possesses strong electron withdrawing ability and can be used as acceptor fragment to form push-pull molecules with intramolecular charge transfer (ICT) character.

In this study, we synthesized 2-phenylquinazoline derivatives with electron donor moieties at position 4. To reinforce electronwithdrawing character of heterocycle ring we modified the structures by introducing cyano and CF<sub>3</sub> group into *para* position of phenyl ring or heteryl residue at position 2 of quinazoline core.

According to synthetic route (Figure 1) corresponding quinazolinone **1** was converted into 4-bromo derivative **2** upon the treatment with POBr<sub>3</sub> in toluene in the presence of triethylamine.[3] Further, bromo-derivatives **2** were introduced into the Pd-catalyzed Suzuki-Miyaura cross-coupling reaction, and desired products **3** were obtained and purified by column chromatography. The synthetic strategy can be utilize for construction of different types donor-acceptor structure.



**Cross-coupling:** arylboronic acid/arylboronic acid pinacol ester, PdCl<sub>2</sub>(PPh<sub>3</sub>)<sub>2</sub>, PPh<sub>3</sub>, K<sub>2</sub>CO<sub>3</sub>, toluene, EtOH, H<sub>2</sub>O, argon, 85 °C, 10-14 h.

**Figure 1.** Synthesis of 2-aryl(heteryl)quinazolines.

It was shown, that on passing from 2-phenyl-4-arylquinazoline to its counterparts bearing electronwithdrawing substituent or heteroatom at 2-phenyl ring the absorption and emission maxima shifted in red region, indicating a stronger intramolecular charge transfer. 4-Diphenylaminoderivatives **3** in each series exhibited the most red-shifted emission, as was previously observed in other families of similar push-pull compounds.[5] Generally, the obtained heterocycles **3** demonstrated luminescence with wide spectral emission range and quantum yield up to 82 % in toluene as well as emission solvatochromism in aprotic solvents. Some of them can be considered as perspective chemosensory for metal cation and H<sup>+</sup> detection.

## References

- [1] Nosova E.V., Achelle S., Lipunova G.N. et al, *Russ. Chem. Rev.* **2019**, *88*, 1128–1178
- [2] Wang Z., Li H., Peng Zh. et al, *RSC Adv.* **2020**, *10*, 30297–30303
- [3] Nosova E. V., Moshkina T.N., Lipunova G.N. et al, *Mendeleev Commun.* **2018**, *28*, 33–35
- [4] Moshkina T.N., le Poul P., Barsella A. et al, *EurJOC*, **2020**, 5445–5454
- [5] Fecková M., le Poul P., Robin-le Guen F., et al, *J. Org. Chem.* **2018**, *83*, 11712–11726

Acknowledgements. This work was supported by the Russian Science Foundation (project No 19-73-10144).

CYTOTOXIC EFFECT OF ORGANOCHALCOGEN COMPOUNDS AGAINST K562  
AND HELA TUMOR CELL LINES.

*Nepochatyi G.D., Bessonov V.V., Popova E.A.*

Saint Petersburg State Institute of Technology, Saint Petersburg, Russia  
[nepochatyy99@yandex.ru](mailto:nepochatyy99@yandex.ru)

It is known that 1,2,3 - thiazoles and their derivatives – benzo[b]thiophenes - have a high synthetic potential, as well as a wide range of biological activity. In particular, 1,2,3 - thiazole derivatives exhibit such properties as antivirus, antitumor, herbicide, fungicide, and insecticide activity. In turn, structures based on benzo[b]thiophenes exhibit anti-cancer, anti-diabetic, anti-tuberculosis, anti-malarial, anti-fungal, anti-depressant, anti-convulsant, anti-hyperglycemic, anti-angiogenic, antimitotic, anti-inflammatory, and analgesic properties. The above information on 1,2,3-thiazole and benzo[b]thiophene derivatives encouraged us to design and synthesize new bioactive agents with the general 4-(2-hydroxyaryl)-1,2,3-thiazole (Figure 1) and 2-aminobenzo[b]thiophene structures (Figure 2). The accumulated products were tested in vitro against erythroleukemia (K562) and cervical carcinoma (HeLa) cell lines. According to the results of the research, the substances 6 and 7b were the most promising compound against both K562 and HeLa cell lines tested. The accumulated experimental data can stimulate further search for pharmacologically active compounds among 4-(2-hydroxyaryl)-1,2,3-thiazole and 2-aminobenzo[b]thiophene derivatives.

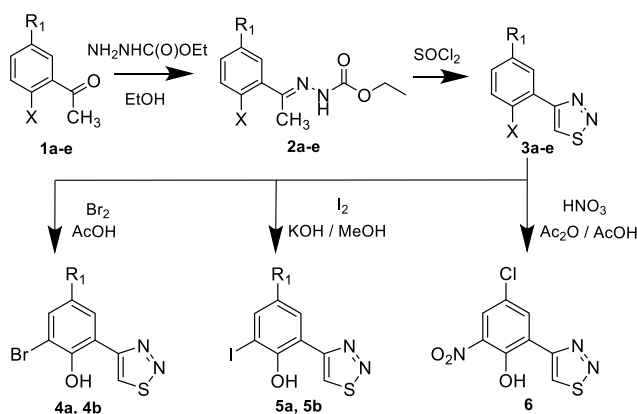


Figure 1. Formation of 1,2,3-thiazoles. 1-3:  $R_1 = H$ ,  $X = Br$  (a);  $R_1 = MeO$ ,  $X = Br$  (b);  $R_1 = NO_2$ ,  $X = Cl$  (c);  $R_1 =$

$Me$ ,  $X = OH$  (d);  $R_1 = Cl$ ,  $X = OH$  (e). 4,5 :  $R_1 = Me$  (a);  $R_1 = Cl$  (b).

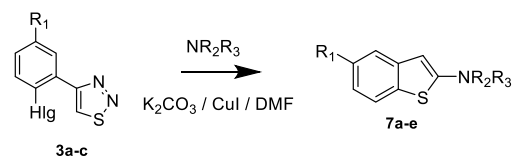


Figure 2. Formation of 2-aminobenzo[b]thiophenes. 7:  $R_1 = H$ ,  $NR_2R_3 =$  pyrrolidin-1-yl (a);  $R_1 = H$ ,  $NR_2R_3 =$  2-ethylpiperidin (b);  $R_1 = H$ ,  $NR_2R_3 =$  morpholin-4-yl (c);  $R_1 = MeO$ ,  $NR_2R_3 =$  morpholin-4-yl (d);  $R_1 = NO_2$ ,  $NR_2R_3 =$  morpholin-4-yl (e).

### References

- [1] Popova E.A., Kornev A. A., Shmakov S. V., Nepochatyi G. D., Kotyunina O. A., Petrov M. L., Boitsov V. M., Stepakov A. V. *Russ. J. Gen. Chem.* **2020**, *90* (11), 2214.  
[2] Popova E.A., Kornev A. A., Shmakov S. V., Bessonov V.V., Androsoy D.A., Petrov M. L., Boitsov V. M., Stepakov A. V. *Russ. J. Gen. Chem.* **2020**, *90* (12), 2400.

Acknowledgements. This work was supported by the Russian Science Foundation (project No 20-15-00332).



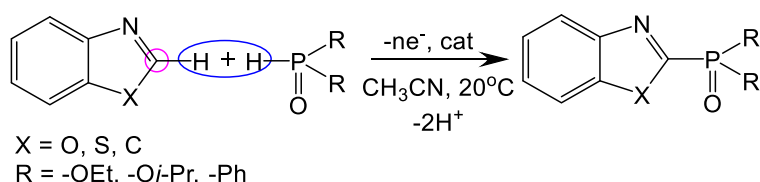
# NEW APPROACH TO OBTAIN IMPORTANT HETEROAROMATIC ORGANOPHOSPHORUS COMPOUNDS

*Nikanshina E.O., Gryaznova T.V., Kholin K.V., Budnikova Y.H.*

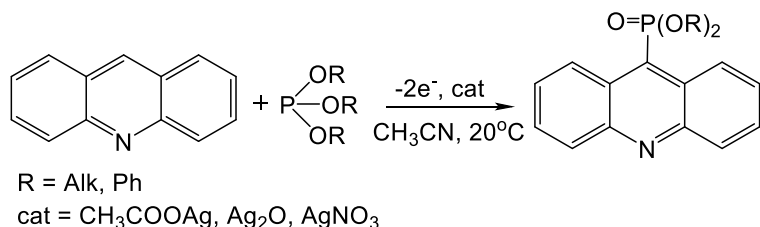
Arbuzov Institute of Organic and Physical Chemistry, FRC Kazan Scientific Center, Russian Academy of Sciences, Kazan, Russia  
PhD Student

[elizaveta.nikanshina@yandex.ru](mailto:elizaveta.nikanshina@yandex.ru)

Arylphosphonates, especially nitrogen-containing derivatives, are widely used in the chemistry of drugs, organic synthesis and as catalysts. The development of new convenient efficient methods of regioselective synthesis of phosphorylated heterocyclic compounds containing N, S, O atoms is important nowadays. The disadvantages of many known reactions usually include the need for a large amount of oxidant, elevated temperatures and a long duration of reaction. Of course, the most attractive method is atom-economical direct C-H functionalization. The development of such environmentally safe and simple catalytic techniques is especially relevant. In this regard, the electrochemical methods that meet the criteria of "green chemistry", characterized by mild conditions (low temperature, normal pressure) and environmentally safe and low-waste processes are very promising [1,2].



**Figure 1.** Electrocatalytic oxidative phosphorylation of benzo-1,3-azoles and their analogues



**Figure 2.** Electrocatalytic oxidative phosphorylation of acridine

## References

- [1] Yurko E.O., Gryaznova T.V., Kholin K.V., Khrizanforova V.V., Budnikova Y.H. *Dalton Trans.* **2018**, 47, 190-196.  
[2] Budnikova Y.H. *Pure Appl. Chem.* **2019**, 91, 17-31.

Acknowledgements. The work is supported by the Russian Science Foundation (grant No. 19-13-00016).

## EFFECT OF ANIONIC POLYSACCHARIDES ON THE PROCESS OF AMYLOID FIBRIL FORMATION

*Nikiforova A.A., Khaibrakhmanova D.R., Sedov I.A.*

Kazan Federal University, Kazan, Russia  
Sirius University of Science and Technology, Sochi, Russia  
PhD Student  
[alnikiforova22@gmail.com](mailto:alnikiforova22@gmail.com)

**Introduction:** Amyloid fibrils cause some neurodegenerative diseases known as amyloidoses. Serum albumin is one of the proteins that are involved in amyloidogenesis in the human body, and forms fibrils at denaturing conditions. In this work, we studied the effect of anionic polysaccharides: sodium alginate, dextran, and k-carrageenan on kinetics of fibrillation of bovine serum albumin.

**Methods:** Albumin fibrils were prepared by incubation of the protein at 65 °C in Tris buffer (pH = 7.4, 0.025 M). Protein concentration was kept constant at 5 mg/ml and the polysaccharide concentration varied from 0 to 1:1 protein:polysaccharide weight ratio. During the experiment, the aliquots were taken to which Thioflavin T solution was added. The fluorescence spectra of Thioflavin T were recorded. Fibril formation causes a sharp increase in fluorescence intensity at the excitation wavelength of 450 nm. The dependence of the fluorescence intensity was plotted against incubation time.

**Results:** The experiments showed that in the presence of polysaccharides, an increase in the rate of formation and concentration of formed fibrils occurred. The largest increase was observed in the presence of k-carrageenan. Addition of polysaccharide to already formed protein fibrils also caused additional fibril formation. This results contrasts with the previously observed ability of alginate and k-carrageenan to disrupt amyloid fibrils of lysozyme.

**Acknowledgements.** This work was supported by the Russian Foundation for Basic Research (project No 19-315-51012).

STEREOSELECTIVE SYNTHESIS OF BIOLOGICALLY RELEVANT FLUOROALKENES  
VIA 2-FLUOROALLYL METAL INTERMEDIATES

*Novikov M.A.*<sup>1</sup>, *Bobrova A. Yu.*<sup>1,2</sup>, *Tomilov Yu. V.*<sup>1</sup>

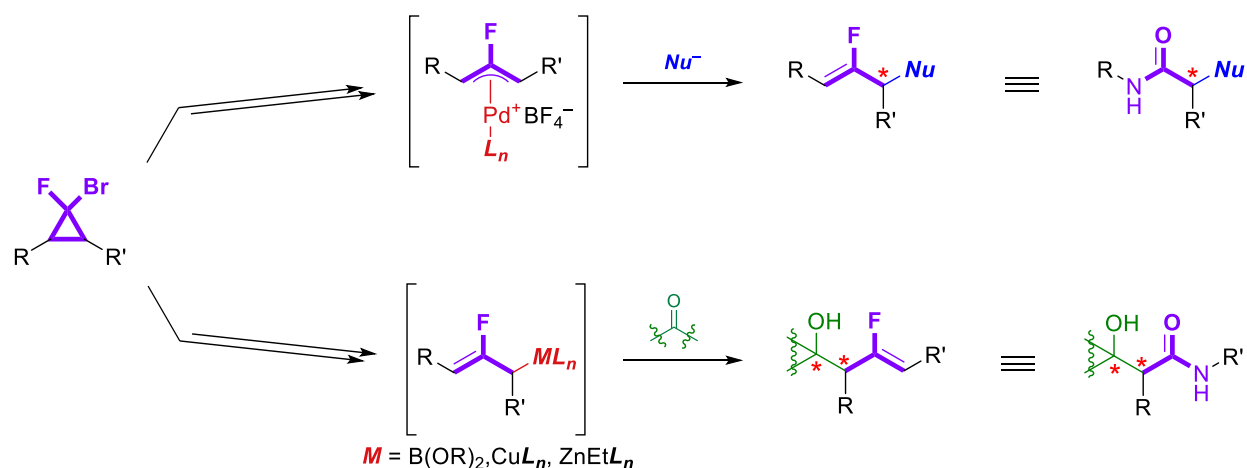
<sup>1</sup> Zelinsky Institute of Organic Chemistry of the RAS, Moscow, Russia

<sup>2</sup> D.I. Mendeleev University of Chemical Technology, Moscow, Russia

Researcher

[manovikov@ioc.ac.ru](mailto:manovikov@ioc.ac.ru)

Replacement of an amide bond with a geometrically and electronically similar isosteric fragment such as fluoroalkenyl moiety is a powerful tool for improving of biological properties in drug design. Herein, we report a general approach for stereoselective synthesis of functionalized fluoroalkenes *via* 2-fluoroallyl metal intermediates where the configuration of the formed stereocenters and the CF=CH double bond can be governed by proper tuning of the metal environment. In this way, Pd-catalyzed 2-fluoroallylation of various nucleophiles *via*  $\eta^3$ -(2-fluoroallyl)palladium complexes gave a variety of 2-fluoroallyl derivatives with high Z-selectivity. The allylic stereocenter in this process can be created enantioselectively using appropriate chiral ligand on Pd. Pre-synthesized or generated catalytically 2-fluoroallyl boron/copper/zinc compounds are efficient nucleophiles for allylation of a carbonyl group (aldehydes and ketones). Relative configuration of the two stereocenters and the configuration of CF=CH double bond in the forming 3-fluorohomoallyl alcohols can be directed by unusual reversibility of 2-fluoroallylic nucleophile addition to carbonyl group that take place in this case. Applications of the developed approach for the synthesis of  $\square$ -[CF=CH]-isosteres with promising biological properties will be also discussed.



### References

- [1] Bobrova A.Yu., Novikov M.A., Tomilov Yu.V., *Org. Biomol. Chem.* **2021**, doi: 10.1039/D1OB00567G.  
 [2] Novikov M.A., Bobrova A.Yu., Mezentsev I.A., Medvedev M.G., Tomilov Yu.V., *J. Org. Chem.* **2020**, *85* (10), 6295–6308.  
 [3] Bobrova A.Yu., Novikov M.A., Mezentsev I.A., Tomilov Yu.V., *J. Fluorine Chem.* **2020**, *236*, 109553.  
 [4] Novikov M.A., Nefedov O.M., *Org. Biomol. Chem.* **2018**, *16* (27), 4963–4967.

Acknowledgements. This work was supported by the Russian Science Foundation (projects No 19-73-00320 and No 19-73-10210) and the Russian Federation President Council for Grants (project No MK-390.2018.3).

TRANSFORMATIONS OF PEROXIDE OZONOLYSIS PRODUCTS OF NATURAL MONOTERPENES UNDER THE ACTION OF CYCLOHEXANECARBOXYLIC ACID HYDRAZIDE

*Nurieva E.R., Myasoedova Yu.V., Garifullina L.R., Ishmuratova G.Yu.*

Ufa Chemistry Institute of Ufa Federal Research Centre of the Russian Academy of Sciences, Ufa, Russia  
Postgraduate student  
[ern\\_lbrn@bk.ru](mailto:ern_lbrn@bk.ru)

In recent years, the synthetic potential of the ozonolysis approach has been extended by using nitrogen-containing reagents which make it possible to obtain functionalized nitrogen compounds such as hydrazones [1], oximes [2], and amines [3] in a one-pot manner.

In this work the results of the study of cyclohexanecarboxylic acid hydrazide as a reducing agent of peroxide products of ozonolysis of (-)- $\alpha$ -pinene and (+)-3-carene in proton-donor (MeOH) and aprotic (methylene chloride, THF) solvents are presented.

The synthesis strategy consists in ozonolytic cleavage of the *tri*-substituted double bond in the above-mentioned monoterpenes **1** or **2** at 0°C and subsequent treatment of the resulting peroxide products with an excess of cyclohexanecarboxylic acid hydrazide. It was shown that in all the solvents used, cyclohexanecarboxylic acid hydrazide is an effective reagent for the conversion of (-)- $\alpha$ -pinene **1** and (+)-3-carene **2** to *N*-{[(1*E*)-1-[(1*R*,3*R*)-2,2-dimethyl-3-[(2*E*)-2-[2-(cyclohexanecarbonyl)hydrazinylidene]ethyl]cyclobutyl]ethylidene]cyclohexanecarbohydrazide **4** and *N*-{[(2*E*)-1-[(1*S*,3*R*)-3-[(2*E*)-2-[2-(cyclohexanecarbonyl)hydrazinylidene]ethyl]-2,2-dimethylcyclopropyl]propan-2-ylidene]cyclohexanecarbohydrazide **7**, respectively. The highest yields of the target cyclobutane- and cyclopropane-containing diacylhydrazones **4** or **7** (83 and 85%) were achieved when the reaction was carried out in methanol; the corresponding ketoesters **5**, **8** were present in the reaction mixture in insignificant amounts (up to 5%). When aprotic solvents were used, the target hydrazones **4**, **7** were also obtained in good yields; however, ketoacids **6**, **9** are present in the reaction mixture in an amount from 14 to 33%. The lowest selectivity was observed in the treatment with cyclohexanoic acid hydrazide of the peroxide products of ozonolysis of 3-carene **2** in methylene chloride (fig.1, table 1).

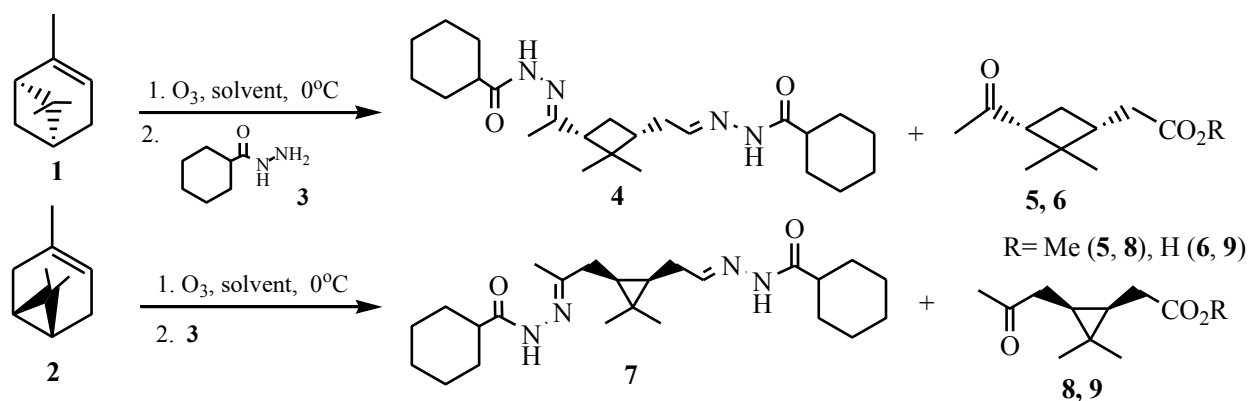


Figure 1

Table 1. Yields of reaction products depending on the used solvent

Monoterpene	Product (yield)		
	MeOH	THF	CH <sub>2</sub> Cl <sub>2</sub>
<b>1</b>	<b>4</b> (83%); <b>5</b> (5%)	<b>4</b> (76%); <b>6</b> (18%)	<b>4</b> (73%); <b>6</b> (14%)
<b>2</b>	<b>7</b> (85%); <b>8</b> (3%)	<b>7</b> (63%); <b>9</b> (17%)	<b>7</b> (59%); <b>9</b> (33%)

References

- [1] Myasoedova, Yu.V., Nazarov, I.S., and Ishmuratov, G.Yu., *Russ. J. Org. Chem.*, **2019**, *55*, 44-73.  
[2] Legostaeva, Yu.V., Garifullina, L.R., Nazarov, I.S., Ishmuratova, N.M., and Ishmuratov, G.Yu., *Russ. J. Org. Chem.*, **2018**, *54*, 1122-1126.  
[3] Kyasa, S.K., Fisher, T.J., and Dussault, P.H., *Synthesis*, **2011**, *2011* (21), 3475-3481.

## ASSESSMENT OF PHARMACOLOGICAL VALUE OF BROWN ALGAE POLYPHENOLS

*Parshina A.E.*<sup>1</sup>, *Bogolitsyn K.G.*<sup>1,2</sup>, *Dorbrodeeva L.K.*<sup>2</sup>, *Samodova A.V.*<sup>2</sup>

<sup>1</sup>Northern (Arctic) Federal University named after M.V. Lomonosov, Arkhangelsk, Russia

<sup>2</sup>Federal Center for Integrated Arctic Research, RAS, Arkhangelsk, Russia

PhD student

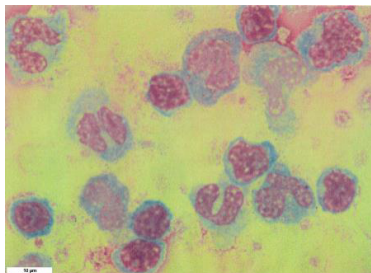
[a.parshina@narfu.ru](mailto:a.parshina@narfu.ru)

Brown algae of the *Fucaceae* family growing in the western Arctic contain a valuable number of polyphenolic components or phlorotannins that possess significant biological activity. Phlorotannins are polymers of phloroglucinol and could count to 20 % of dried biomass. They differ in degree of polymerization, type of bounds between phloroglucinol units, and the number of hydroxyl groups. The molecular weight of brown algae polyphenols varies over a wide range from 126 Da to 650 kDa. Structural differences in phlorotannin macromolecules determine the diversity of biological activity of these compounds, which include strong antioxidant properties, hepatoprotective, anti-allergic, antitumor, anti-inflammatory, antidiabetic, antifungal activity, etc. Previously it was established that polyphenols are capable of interacting with cells (leukocytes, erythrocytes, epithelial cells) without disturbing their integrity, but promoting adsorptive properties [1]. The present study aims to evaluate the antitumor activity of brown algae polyphenols.

Polyphenols (PP) were isolated from the brown algae *Fucus vesiculosus* according to the scheme proposed by the authors, with 70% acetone extraction, and subsequent fractionation by solid-phase extraction [2]. The active polyphenolic fraction contains 97% polyphenols with antioxidant activity of 882 mg of ascorbic acid for 1 g of extract.

Antitumor activity *in vitro* was studied using leukocyte suspension of venous blood (21 samples) of patients with lymphocytic leukemia. Evaluation of intercellular interactions and cell adhesion to glass was used as a criterion. Extension, phagosome formation, degranulation, and nucleoli formation were taken into account as markers of cell activation after contact with PP.

It was found that the polyphenol fraction increases the content of all types of adhered leukocytes by 1.5-2 times, among which lymphocytes predominate:  $63.4 \pm 2.05\%$ . Stimulation of adhesion is non-specific and dose-dependent. Polyphenols of brown algae stimulate leukocyte extension more than 3 times. In the presence of PP, there is an increase in the number of cells with phagosomes among leukocytes. There is a noticeable increase in the content of cells with morphologically pronounced nucleoli. The PP fraction increases the number of cells forming traps almost 6 times.



**Figure 1.** Extension, nucleoli, and phagosome formation in peripheral venous blood. Romanowsky-Giemsa staining, magnification 1000

Intercellular interactions of granulocytes, monocytes, lymphocytes are one of the forms of participation of these cells in preventive reactions, inflammation, and immune responses. A tumor cell, losing its ability to intercellular interactions, becomes autonomous, completely independent. Unstable or weakened cell contacts are the first step towards tumor transformation. For the mechanisms of the antitumor activity of the organism to work, the effector cells must contact the tumor cell. As a result of the present research, a stimulating effect of brown algae polyphenols on intercellular interactions in the lymphocytic suspension of venous blood of patients with lymphocytic leukemia *in vitro* was revealed. It is expressed in increased adhesion, extension, formation of nucleoli and phagosomes. These effects indicate the activation of the protective mechanisms of cells, as a result, the prospects for the use of polyphenols of brown algae as active components of antitumor drugs.

### References

- [1] Bogolitsyn K.G. et al. *J. Appl. Phycol.* **2021** [in print]
- [2] Bogolitsyn K.G. et al. *J. Appl. Phycol.* **2020**, *36*, 4277-4287

Acknowledgements. This work was supported by state assignment, project No 0793-2020-0005, and Russian Foundation for Basic Research (project No 20-33-90004\20).

# NOVEL EFFECTIVE CHELATORS FOR THERAPEUTIC RADIONUCLIDES

*Pashanova A.V.<sup>1,2</sup>, Zubenko A.D.<sup>1</sup>, Matazova E.V.<sup>3</sup>, Egorova B.V.<sup>3</sup>*

<sup>1</sup>INEOS RAS, Moscow, Russia

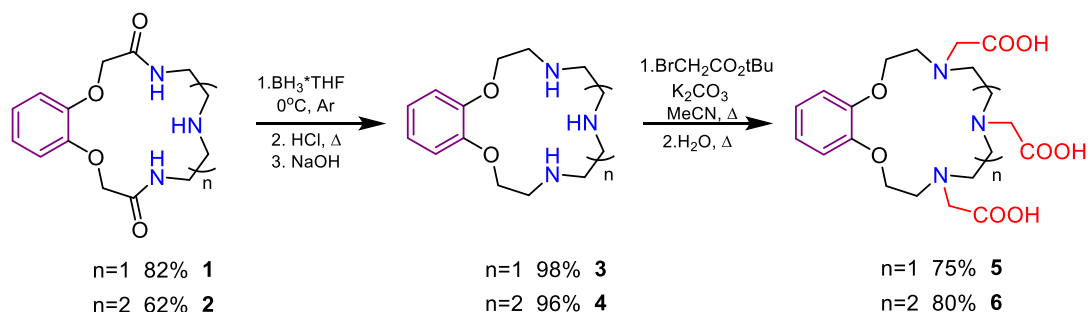
<sup>2</sup>D. Mendeleev University of Chemical Technology of Russia, Moscow, Russia

<sup>3</sup>Moscow State University, Moscow, Russia

Student

[1404an99@mail.ru](mailto:1404an99@mail.ru)

The synthesis of metal-based pharmaceuticals by labelling biomolecules with radioactive metal ions has seen an impetuous growth over the last years [1]. The most reliable and most frequently applied method of linking the metal ion (the probe) to the biomolecule (the carrier) is by means of a bifunctional chelating agent. Chelating agents, such as DOTA and DTPA, are used to label targeting molecules. Complexes with azacrown ether DOTA are highly stable in challenging conditions in vitro and in vivo but kinetics of radionuclide's binding is quite slow and only elevated temperatures up to 100°C facilitate complexation. In contrast DTPA chelates cations instantaneously at room temperature but formed complexes release radiometals in vitro and in vivo [2]. In our work, we attempted to combine the macrocyclic effect of azacrown ethers with the mobility of acyclic ligands, for which the ligands **5** and **6** with a large macrocyclic cavity and carboxylic pendant arms were synthesized (Figure 1).



**Figure 1.** Synthesis of ligands.

Potentiometric titration of **5** and **6** has been carried out in the presence of equimolar  $\text{Cu}^{2+}$ ,  $\text{Pb}^{2+}$ ,  $\text{Sc}^{3+}$ ,  $\text{Y}^{3+}$  and  $\text{Bi}^{3+}$  ions to determine the stability constants of the corresponding metal complexes:

Ligand	lgK				
	$\text{Cu}^{2+}$	$\text{Pb}^{2+}$	$\text{Sc}^{3+}$	$\text{Y}^{3+}$	$\text{Bi}^{3+}$
<b>5</b>	18,4	14,0	14,2	11,4	26,9
<b>6</b>	23,9	22,3	21,17	17,4	32,5

The stability of the studied complexes is reasonably high according to thermodynamic stability constants. The most stable complex was obtained for the ligand **6** with  $\text{Bi}^{3+}$ . As a consequence, ligand **6** was evaluated as a carrier for  $^{213,212}\text{Bi}$  ions for nuclear medicine applications. The labelling yield reached >96% at pH 6 for **6** and >98% at pH 7 for **5**. The results of serum challenge show that there was not any significant  $^{207}\text{Bi}^{3+}$  protein binding in case of  $^{207}\text{Bi}$ ·**6**-Bi even after 2 days which points on remarkable complex stability. In vivo experiments showed that the  $^{207}\text{Bi}$ ·**6**-Bi complex is rapidly excreted from the body and no significant accumulation of radioactivity in any healthy tissues was observed.

Thus, our studies have shown that the ligand **6** can be considered as an ideal chelator for  $\text{Bi}^{3+}$ . The functionalization of **6** on the phenyl core may allow the preparation of conjugates with biomolecules including heat-sensitive and lead to the creation of therapeutic radiopharmaceuticals containing short-lived bismuth radioisotopes.

## References

- [1] *Chem. Soc. Rev.*, **2011**, 40, 3019–3049  
 [2] *Med. Chem. Commun.*, **2019**, 10, 1641-1645

Acknowledgements. This work was supported by the Russian Science Foundation (project No 17-73-30036-П).

NOVEL THERANOSTIC AGENTS FOR PHOTODYNAMIC THERAPY BASED ON BACTERIOCHLORIN AND NAPHTHALIMIDE DERIVATIVES

*Pavlova M.A.*<sup>1</sup>, *Panchenko P.A.*<sup>1</sup>, *Fedorova O.A.*<sup>1</sup>, *Pritmov D.A.*<sup>2</sup>, *Mironov A.F.*<sup>2</sup>

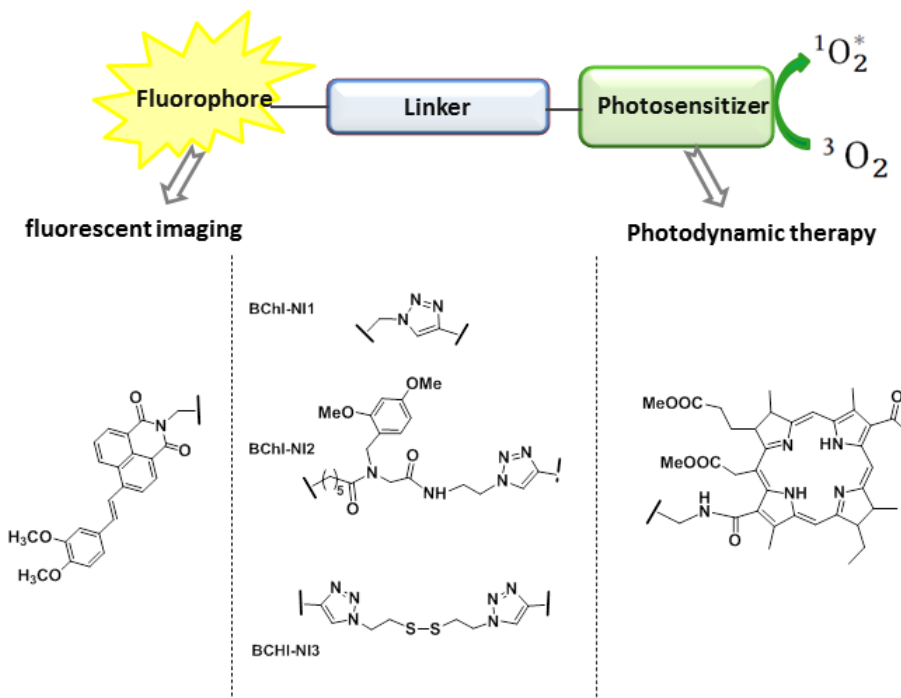
<sup>1</sup>INEOS RAS, Moscow, Russia

<sup>2</sup> MIREA – Russian Technological University, Moscow, Russia

Young scientist

pavlova\_m@ineos.ac.ru

Theranostics is a new approach to cancer treatment based on using drugs which can provide both the diagnosis and the therapy. The effectiveness of the widely used method of photodynamic therapy (PDT) could be significantly improved by using theranostic drugs for preliminary visualization of the tumor in the body, as well as monitoring the dynamics of treatment. In this work we propose the synthesis, photophysical and biological studying of theranostics for PDT combining covalently bonded functional fragments: photosensitizer (bacteriochlorin) and fluorophore (naphthalimide), which could be excited by different wavelengths to serve therapy or fluorescent diagnostics (figure 1).



**Figure 1.** The schematic representation of the conjugates and structures of their components.

The molecular design of the conjugate must be directed to minimizing the process of photoinduced energy transfer from the naphthalimide fragment to the photosensitizer, because it leads to the fluorophore emission quenching [1,2]. We have synthesized and studied the optical properties of conjugates with three types of spacers separating the chromophores: with a short linker of two methylene groups and a triazole fragment, with a peptide linker, and with a spacer containing a disulfide bond cleaving inside cells. The fluorescent properties of the conjugates were investigated in solution and at cell culture [3]; the photodynamic activity of the conjugates was evaluated *in vitro* and *in vivo* and compared with characteristics of the initial photosensitizer.

#### References

- [1] Panchenko P.A., Grin M.A., Fedorova O.A. et al., *Phys. Chem. Chem.Phys.*, **2017**, *19*, 30195–30206.
- [2] Panchenko P.A., Zakharko M.A., Grin M.A. et al. *J. Photochem. Photobiol. A*, **2020**, *390*, 112338.
- [3] Zakharko M.A., Panchenko P.A., Zarezin D.P. et al., *Russ. Chem.Bull.*, **2020**, *6*, 1169–1178.

Acknowledgements. This work was supported by the Russian Science Foundation (project No 21-73-20158).

## DEVELOPMENT OF PHOTOSWITCHABLE LIGANDS FOR DNA BASED ON CHROMENE DERIVATIVES

*Perevozchikova P.S.*<sup>1,2</sup>, *Chernikova E.Y.*<sup>2</sup>, *Shepel N.E.*<sup>2</sup>, *Fedorov Y.V.*<sup>2</sup>, *Fedorova O.A.*<sup>1,2</sup>

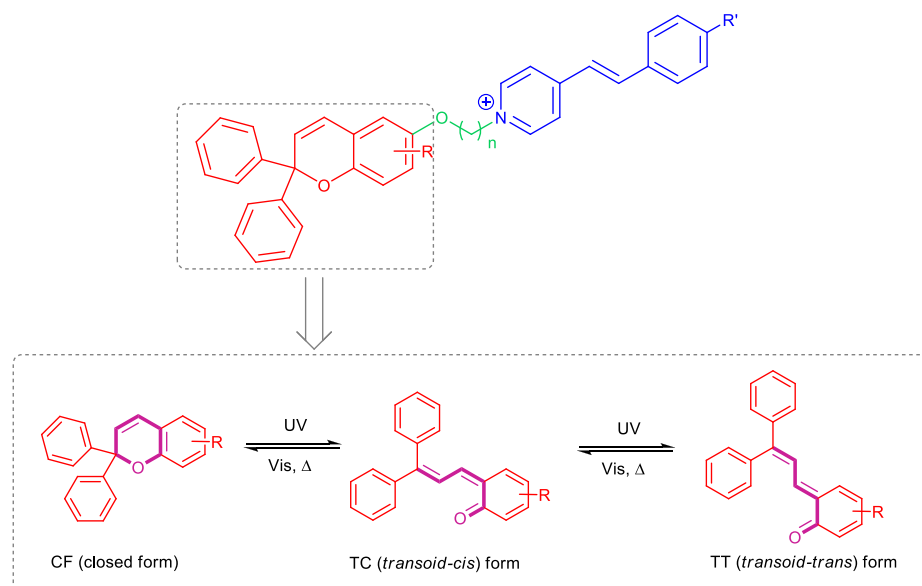
<sup>1</sup>D.I. Mendeleev University of Chemical Technology of Russia, Moscow, Russia

<sup>2</sup>A.N.Nesmeyanov Institute of Organoelement Compounds of Russian Academy of Sciences, Moscow, Russia  
PhD student

[polina-krasnooperova@mail.ru](mailto:polina-krasnooperova@mail.ru)

Currently it is especially important to study the interaction of DNA with organic molecules that can intercalate between two complementary base pairs, thereby changing its functions. The use of photochromic compounds as intercalators is of high importance for the development of new drugs with photoswitchable pharmacological activity against various diseases.

Therefore, the aim of our study is to develop photoswitchable ligands for DNA, which combine a photochromic chromene moiety and a styryl dye with positive charge (Fig. 1). The dye has an affinity for binding to the DNA molecule, therefore it will facilitate the coordination of the ligand. Chromene in its closed form doesn't interact with DNA due to its structural features. But upon irradiation, it undergoes a photochromic transformation into open planar merocyanine forms, which are capable of coordination with DNA [1]. In addition, it is proposed to vary the spacer between the dye and chromene in order to reveal the optimal structure of the photoswitchable ligand for DNA.



**Figure 1.** General structures of photoswitchable ligands for DNA.

The interaction with DNA and the photochromic properties of chromenes and conjugates have been investigated by UV/Vis absorption and fluorescence spectroscopies, CD spectroscopy, flash photolysis, <sup>1</sup>H and 2D NMR spectroscopies. The photochromic properties of the resulting compounds were explored at different temperatures. The kinetic studies revealed the high stability of their open isomers [2]. In the study of interaction with DNA, it was found that both the styryl dye and the chromene moiety are capable of coordination with DNA.

### References

- [1] Paramonov S.V., Lokshin V., Ihmels H., Fedorova O.A. *Photochem. Photobiol. Sci.* **2011**, *10*, 1279–1282
- [2] Perevozchikova P.S., Aliev T.M., Nikitina P.A., Shepel N.E. *INEOS OPEN* **2021**, *4*, 29–34

Acknowledgements. This work was supported by the Russian Science Foundation (project No 19-43-04127).



## ANTITUMOR ACTIVITY OF PEPTIDES INHIBITING THE GROWTH FACTOR OF VESSEL ENDOTHELIUM

Petrova A.L., Malkova A.M., Sharoyko V.V., Tennikova T.B., Guryanov I.A.

Saint Petersburg State University, Saint Petersburg, Russia

Student

[hudec2008@gmail.com](mailto:hudec2008@gmail.com)

One of the key factors of the tumor progression and metastasis is the enhancement of angiogenesis in the tumor area, caused by the hypoxia and increased secretion of proinflammatory cytokines [1-2]. The most important mediator of angiogenesis is endothelial vascular growth factor (VEGF), secreted by tumor cells and the tumor microenvironment.

Along with low molecular weight compounds, inhibitors of endogenous VEGF, such as antibodies to VEGF (Bevacizumab, Pegaptanib) and the "soluble" receptors (Aflibercept) are most widely used for the treatment of pathological angiogenesis. However, their low stability to enzymatic degradation, rapid elimination and the risk of complications noticeably limit their use in the antiangiogenic therapy [3-5].

The development of small peptide inhibitors of VEGF may lead to the new efficient anti-angiogenic therapeutic agents for the treatment of cancer. Peptides are promising candidates as antiangiogenic drugs, since they are small compared to antibodies, non-immunogenic and have high selectivity and low toxicity. They can be easily synthesized and modified to enhance their biological activity and resistance to proteolysis [6].

In this study we synthesized and tested VEGF-binding peptides, Aib2 (VUPNc[CDIHV<sup>n</sup>LWEWEC]FERL-NH<sub>2</sub>), kv114\* (KUKKc[CDIHV<sup>n</sup>LWEWEC]FERL-NH<sub>2</sub>) and v114\* (VEPNc[CDIHV<sup>n</sup>LWEWEC]FERL-NH<sub>2</sub>). Evaluation of the antiproliferative effect of the peptides was performed using MTT test with human lung adenocarcinoma cells (A549), human embryonic kidney cell line (HEK-293) was used as a control cell line. The results showed that the peptides selectively blocked VEGF signaling pathways of A549 cancer cells, while no effect on healthy cells was found.

### References

- [1] Zondor S.D., Medina P.J. *Ann. Pharmacother.* **2004**, *38*, 1258–1264.
- [2] Bold G. et al. *J. Med. Chem.* **2000**, *43*, 2310–2323.
- [3] Glade-Bender J., Kandel J.J., Yamashiro D.J. *Expert Opin. Biol. Ther.* **2003**, *3*, 263–276.
- [4] Supuran C.T. *Expert Opin. Ther. Pat.* **2019**, *29*, 761–767.
- [5] Holash J. et al. *Proc. Natl. Acad. Sci. U. S. A.* **2002**, *99*, 11393–11398.
- [6] D'Andrea L. et al. *Curr. Pharm. Des.* **2009**, *15*, 2414–2429.

Acknowledgments. The study was performed with the financial support of the Megagrant of the Government of the Russian Federation: "Biohybrid technologies for modern medicine" No. 14.W03.31.0025.

Rh(III)-CATALYSED C-H ACTIVATION/ANNULATION OF ARYL HYDROXAMATES  
WITH CF<sub>3</sub>-CONTAINING  $\alpha$ -PROPAGYLE  $\alpha$ -AMINO ACID DERIVATIVES

*Petropavlovskikh D.A.<sup>1</sup>, Vorobyeva D.V.<sup>1</sup>, Osipov S.N.<sup>1</sup>*

<sup>1</sup>A.N. Nesmeyanov Institute of Organoelement Compounds, RAS, Moscow, Russia

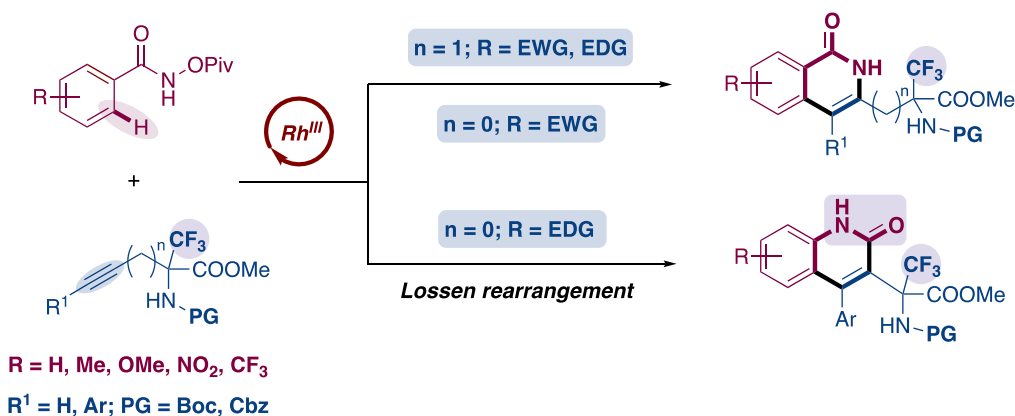
PhD Student

[dmitrypetrpavl@gmail.com](mailto:dmitrypetrpavl@gmail.com)

Over the last two decades, the fluorine chemistry has become a major area of multidisciplinary research modernising healthcare, food, and energy industries. The remarkable reactivity, physico-chemical and biological properties of fluorinated compounds are widely used today for the development of innovative technologies [1]. In the field of amino acids and peptides, special attention is focused on the  $\alpha$ -amino acids with fluoromethyl groups in  $\alpha$ -position due to their ability to function as the highly selective inhibitors of pyridoxal phosphate-dependent enzymes exhibiting a range of interesting biological properties. Therefore, the development of new representatives of the  $\alpha$ -fluoromethyl- $\alpha$ -amino acids is of great interest [2].

On the other hand, metal-catalysed tandem C-H activation/annulation of aromatic amides with alkynes under the chelation control of an appropriate directing group has become a powerful strategy for constructing isoquinolone skeletons from cheap starting materials in a step- and atom-economical manner [3].

We have developed a convenient pathway to the novel  $\alpha$ -CF<sub>3</sub>- $\alpha$ -amino acid derivatives decorated with the pharmacophore isoquinolone and quinolone cores *via* the intermolecular Rh(III)-catalysed C-H activation/annulation of aryl amides with  $\alpha$ -CF<sub>3</sub>-substituted  $\alpha$ -alkynyl- $\alpha$ -amino acid derivatives [4].



**Figure 1.** C-H activation of aryl hydroxamates and CF<sub>3</sub>-containing  $\alpha$ -amino acid derivatives.

The outcome of the reaction with  $\alpha$ -arylethynyl- $\alpha$ -amino carboxylates is controlled by the electronic effects of the substituents in the compound activated: electron-withdrawing groups result in the regular product of the C-H activation whereas electron-donating groups lead to the Lossen rearrangement with the inversion of the amide group in the forming heterocycle ring.

#### References

- [1] Haufe G., Leroux F. *Academic Press, 1<sup>st</sup> edition*. 1–686
- [2] Nie J., Guo H-Ch., Cahard D, Ma J-A. *Chemical Reviews*. **2011**, *111*, 455–529
- [3] Hyster T.K., Rovis T. *Journal of America Chemical Society*. **2010**, *132*, 30, 10565–10569
- [4] Vorobyeva D.V., Petropavlovskikh D.A., Godovikov I.A., Nefedov S.E., Osipov S.N. *European Journal of Organic Chemistry*. **2021**, 1883

Acknowledgements. This work was supported by the Russian Science Foundation (project No. 21-13-00328).

SYNTHESIS OF UNSATURATED CF<sub>3</sub>-DERIVATIVES OF ORNITIN, LYSINE  
AND THEIR PHOSPHORIC ANALOGUES

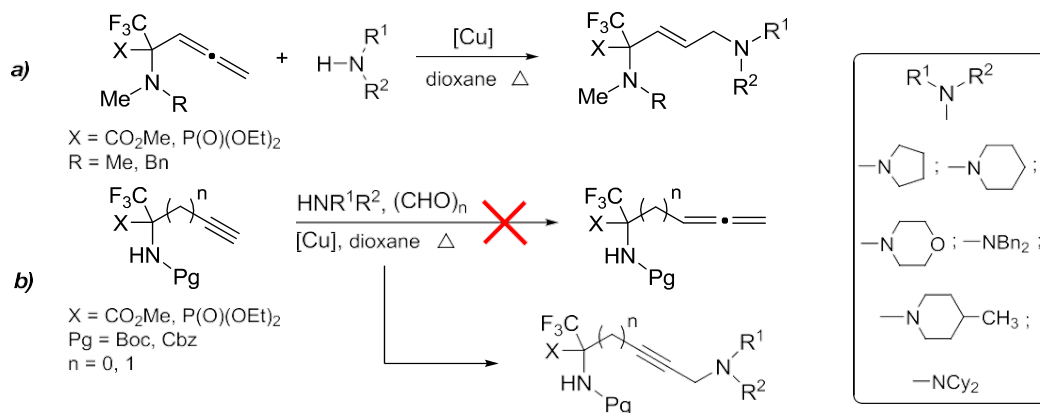
*A.N. Philippova<sup>1</sup>, P.S. Gribanov<sup>1</sup>, D.V. Vorobyeva<sup>1</sup>, S.N. Osipov<sup>1</sup>*

<sup>1</sup>A.N. Nesmeyanov Institute of Organoelement Compounds of Russian Academy of Sciences,  
Moscow, Russia  
PhD Student  
[anyfil96@gmail.com](mailto:anyfil96@gmail.com)

Unsaturated  $\alpha$ -amino acids are very important building blocks in organic and medicinal chemistry, mainly as a result of the diverse reactivity of the multiple bonds and their ability to introduce biologically active functionalities [1]. Thus, they have proved to be extremely useful for a range of transformations, particularly metal-catalyzed functionalizations such as cross-coupling, cycloaddition as well as metathesis-type reactions [2]. Moreover, unsaturated  $\alpha$ -amino acids currently play an important role in peptide chemistry due to their facile incorporation into protein structures.

On the top of this, the introduction of fluorine or fluoroalkyl substituents into biological relevant compounds has become an important tool in the drug discovery process. Special attention is paid to trifluoromethyl-containing compounds due to the unique properties of the trifluoromethyl group, such as high electro-negativity, electron density, steric hindrance, and hydrophobic character that can profoundly improve the pharmaco-kinetic profiles of potential drugs. Furthermore, it is known, that the  $\alpha$ -trifluoromethyl- $\alpha$ -amino acids are capable of functioning as highly selective inhibitors of pyridoxal phosphate-dependent enzymes, while exhibiting a wide range of biological properties [3].

Previously, we studied the copper(I)-catalyzed hydroamination of fluorine-containing  $\alpha$ -allenyl- $\alpha$ -aminocarboxylates with primary and secondary amines (Scheme 1a), which made it possible to develop an effective method for the synthesis of a series of new *E*-dehydroornithine derivatives [4]. Continuing research in this area, during the reporting period, we studied the possibility of extending the side chain of  $\alpha$ -CF<sub>3</sub>- $\alpha$ -amino acids using the reaction of  $\alpha$ -alkynyl derivatives with paraformaldehyde in the presence of amines under catalysis with copper salts. However, it was found that under these conditions the Mannich reaction is realized, leading to the formation of the corresponding unsaturated CF<sub>3</sub>-derivatives of lysine (Scheme 1b). The process is also successfully carried out in the case of  $\alpha$ -aminophosphonates.



**Scheme 1.** Synthesis of unsaturated derivatives of ornithine and lysine.

### References

- [1] Rutjes F.P.J.T., Wolf L.B., Schoemaker H.E. *J. Chem. Soc. Perkin Trans.* **2000**, *1*, 4197
- [2] Kaiser J., Kinderman S.S., van Esseveldt B.C., van Delft F.L., Schoemaker H.E., Blaauw R.H., Rutjes F.P.J.T. *Org. Biomol. Chem.* **2005**, *3*, 3435
- [3] Moschner J., Stulberg V., Fernandes R., Huhmann S., Leppkes J. and Kokschi B. *Chem. Rev.* **2019**, *119*, 10718
- [4] Philippova A.N., Vorobyeva D.V., Monnier F., Osipov S.N. *Org. Biomol. Chem.* **2020**, *18*(17),3274.

Acknowledgements. This work was supported by the Russian Foundation for Basic Research (project № 20-33-90233).

# CATIONIC DINITROSYL IRON COMPLEXES WITH THIOUREA DERIVATIVES: TRANSFORMATION IN AQUEOUS SOLUTIONS AND INFLUENCE ON THE ENZYMIC ACTIVITY OF PHOSPHODIESTERASE

*Pokidova O.V.*<sup>1</sup>, *Emel'yanova N.S.*<sup>1,2</sup>, *Psikha B.L.*<sup>1</sup>, *Tatyanenko L.V.*<sup>1</sup>, *Kotelnikov A.I.*<sup>1,2</sup>, *Sanina N.A.*<sup>1,2,3</sup>

<sup>1</sup>Institute of Problems of Chemical Physics, Russian Academy of Sciences, Chernogolovka, Moscow Region, Russia

<sup>2</sup>Lomonosov Moscow State University, Moscow, Russia

<sup>3</sup>Medicinal Chemistry Research and Education Center, Moscow Region State University, Mytishchy, Moscow Region, Russia

Senior Researcher

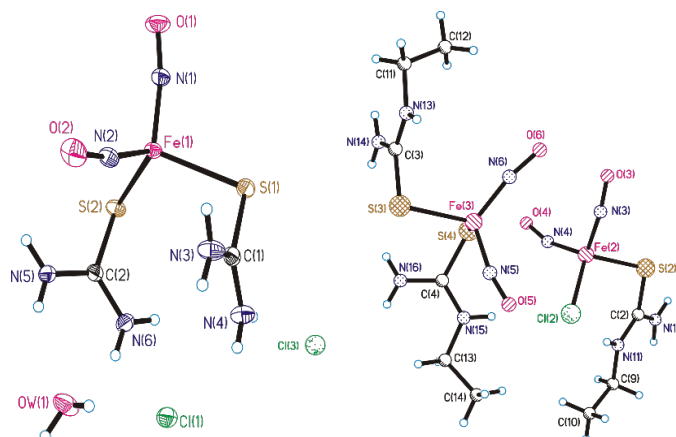
[pov@icp.ac.ru](mailto:pov@icp.ac.ru)

NO is a signaling molecule involved in the regulation of cardiovascular tone, neural transmission, apoptosis, and immune defense [1]. Due to the discovery of the fundamental role of nitrosyl iron-sulfur complexes as natural NO carriers, their synthetic analogs are of considerable interest as promising drugs.

We have investigated  $[\text{Fe}(\text{SC}(\text{NH}_2)_2)_2(\text{NO})_2]\text{Cl}\cdot\text{H}_2\text{O}$  (complex 1) [2] and  $[\text{Fe}(\text{SC}(\text{NH}_2)(\text{NHC}_2\text{H}_5))_2(\text{NO})_2]^+\text{Cl}^-$ · $[\text{Fe}(\text{SC}(\text{NH}_2)(\text{NHC}_2\text{H}_5))\text{Cl}(\text{NO})_2]^0$  (complex 2) [3] (Fig. 1), which are promising compounds for NO treatment of socially significant diseases. These complexes have therapeutic potential for the treatment of cardiovascular diseases [4]. In addition, complex 2 showed high cytotoxic activity against glioblastoma cells [2].

The aim of this work was to study the transformation of the complexes (including NO-donor activity) and their effect on the activity of cGMP phosphodiesterase (PDE). The action of the complexes on two key enzymatic systems, guanylate cyclase (by generating NO) and PDE, will stimulate a sharp increase in the content of cyclic nucleotides, which in turn will lead to vascular smooth muscle relaxation and vasodilation.

The anaerobic process of decomposition of complexes was studied using UV-Vis spectrophotometry, amperometry, quantum-chemical and kinetic modeling. A decomposition reaction scheme was proposed and rate constants were calculated.



**Figure 1.** Molecular structure of the complex 1 and 2.

It was also shown that complexes in a concentration of  $10^{-4}$  M inhibited PDE function by  $(87\pm 9)\%$  (complex 1) and  $(82\pm 8)\%$  (complex 2). Ligands do not significantly affect the activity of the enzyme. These data suggest that the studied complexes can exhibit antimetastatic, anti-aggregation, vasodilatory, and antihypertensive activities.

## References

- [1] Ignarro L.J., *J. Physiol. Pharmacol.* **2002**, *53*, 503–514.
- [2] Sanina N.A., Aldoshin S.M., Shmatko N.Y., Korchagin D.V., et. al. *Inorg. Chem. Commun.* **2014**, *49*, 44–47
- [3] Sanina N.A., Shmatko N.Y., Korchagin D.V., Shilov G.V., et. al. *J. Coord. Chem.* **2016**, *69*, 812–825
- [4] Akentieva N.P., Sanina N.A., Gizatullin A.R., Shkondina N.I., et. al. *Front. Pharmacol.* **2019**, *10*, 1277

**Acknowledgements.** The study of the transformation of complex 1 was performed in accordance with the state task, state registration No AAAA-A19-119071890015-6. The study of the transformation of complex 2 was supported by the Russian Science Foundation (project No. 20-73-00316).

# NEW DICATIONIC PORPHYRINS FOR ANTIMICROBIAL PHOTODYNAMIC THERAPY

*Polivanovskaia D.A.,<sup>a</sup> Birin K.P.,<sup>a</sup> Gorbunova Yu.G.,<sup>a,b</sup> Tsvadze A.Yu.<sup>a,b</sup>*

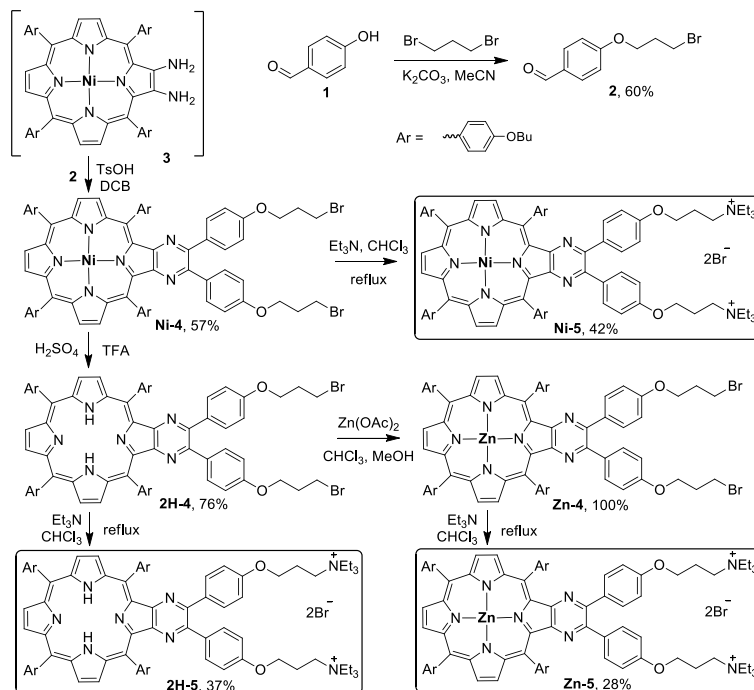
<sup>a</sup>*A.N. Frumkin Institute of physical chemistry and electrochemistry RAS,  
Leninsky prosp. 31, bldg. 4, Moscow, 119071, Russia*

<sup>b</sup>*N.S. Kurnakov Institute of general and inorganic chemistry RAS, Leninsky prosp. 31, Moscow, 119991, Russia  
Junior researcher*

[dpolivanovskaya@mail.ru](mailto:dpolivanovskaya@mail.ru)

A variety of porphyrins is investigated as photosensitizers for antibacterial photodynamic therapy (aPDT) to date. The successful application of the porphyrin type photosensitizers requires efficient singlet oxygen generation, solubility in biorelevant media and affinity to bacterial cell membranes. An extremely lipophilic nature of porphyrins requires introduction of hydrophilic functional groups into these macrocycles to enhance their solubility in water. In turn, pyrazine-annulated porphyrins are considered as a convenient platform for introduction of different functional groups to the periphery of the molecule to control its physical-chemical properties, for example, solubility in different solvents [1].

The previously developed strategy of  $\beta,\beta'$ -functionalization of porphyrins allowed to synthesize pyrazine-annulated derivatives with different peripheral functional groups [2-3]. It was assumed that the introduction of terminal ammonium fragments into porphyrin molecule could allow enhancement of both the solubility of the molecule in water and the affinity to the cell membranes or artificial bilayer lipid membrane as a model. The applied synthetic approach consists in the reduction of 2-nitro-3-aminoporphyrin and subsequent condensation of the resulting 2,3-diaminoporphyrin **3** with 4-(bromopropyl)-benzaldehyde **2**. The performed reaction sequence allowed obtaining the dicationic pyrazinoporphyrim **2H-5** and its metal complexes **Ni-5** and **Zn-5** (Scheme 1).



**Scheme 1.**

The prepared dicationic porphyrins exhibit amphiphilic properties, demonstrating solubility both in aprotic polar ( $\text{CH}_2\text{Cl}_2$ ,  $\text{CHCl}_3$ ) and in protic polar solvents ( $\text{H}_2\text{O}$ ,  $\text{MeOH}$ ). The obtained Zn(II) porphyrinate **Zn-5** is expected to possess higher photoactivity compared to free-base **2H-5** resulting from the heavy atom enhanced generation of singlet oxygen. In this respect the application of the prepared new photosensitizers in aPDT is a current object of the ongoing research.

## References

- [1] Abdulaeva, I. A. et al. *Coord. Chem. Rev.* **2020**, 407, 213108.
- [2] Abdulaeva I.A. et al. *RSC Adv.* **2020**, 10, 69, 42388–42399.
- [3] Birin K.P. et al. *Dyes Pigm.* **2018**, 156, 243-249.

Acknowledgements. This work was supported by RSF (grant №19-13-00410)

# NOVEL TYPE OF NO-DONOR AZOFUROXANS PHOTOSWITCHES

*Polkovnichenko M.S.*<sup>1,2</sup>, *Zhilin E.S.*<sup>1</sup>, *Fershtat L.L.*<sup>1</sup>, *Makhova N.N.*<sup>1</sup>

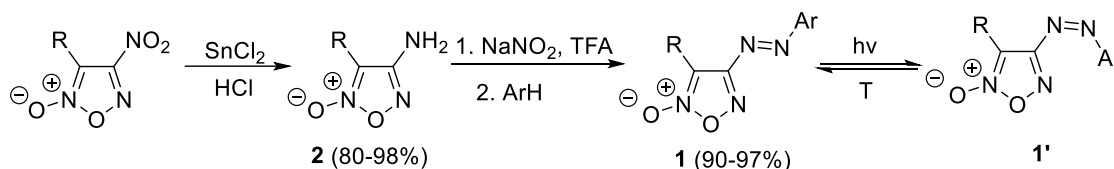
<sup>1</sup>N.D. Zelinsky Institute of Organic Chemistry, Russian Academy of Sciences  
47 Leninsky prosp., 119991 Moscow, Russian Federation

<sup>2</sup>Department of Chemistry, Moscow State University, 119991 Moscow, Leninskie Gory 1-3, Russian Federation

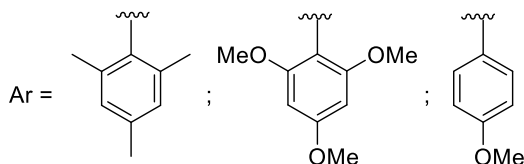
E-mail: [aaaa0000www4444@yandex.ru](mailto:aaaa0000www4444@yandex.ru)

An important focus in modern medicinal chemistry is the search of compounds able to release NO (NO-donors) in the body, either enzymatically or independently of NO synthases. Among them, the furoxan moiety has been the subject of increased attention owing to a number of interesting biological activities related to the ability of furoxans to exogenous NO release in the presence of thiol cofactors.<sup>1</sup> The incorporation of the furoxan motif as a potential NO-donor into drug candidates with known pharmacological activity has been widely used in the last decade and new furoxan-containing structures with neuroprotective and precognitive, cytotoxic, antihelmintic, antibacterial, and antiaggregant activities were revealed.<sup>2</sup>

In recent years, photopharmacology became an emerging approach in medicine in which drugs are activated and deactivated with light. Arguably, azo(het)arenes are among the most studied so far compounds capable to photoswitch. In present work, an ability of arylazofuroxans **1** incorporating N=N bond to photoisomerization as well as their NO-donor properties have been investigated. Synthesis of arylazofuroxans **1** is based on a diazotization of readily available amines **2** [3] with subsequent azo coupling of *in situ* formed diazonium salts with electron-donor arenes. It is worth mentioning that (*Z*)-isomers **1'** which are formed upon visible light irradiation can be thermally isomerized to the initial (*E*)-arylazofuroxans **1** with quantitative yields.



R = Ph, 4-MeOC<sub>6</sub>H<sub>4</sub>, 2-FC<sub>6</sub>H<sub>4</sub>, 3-FC<sub>6</sub>H<sub>4</sub>, 4-FC<sub>6</sub>H<sub>4</sub>, 4-BrC<sub>6</sub>H<sub>4</sub>, Me, CO<sub>2</sub>Me



## References

- [1] L. L. Fershtat, N. N. Makhova, *Russ. Chem. Rev.* **85**, 1097 (2016).  
 [2] L. L. Fershtat, N. N. Makhova, *ChemMedChem* **12**, 622 (2017).  
 [3] L. L. Fershtat, D. M. Bystrov, E. S. Zhilin, N. N. Makhova, *Synthesis*, **2019**, 51, 747.

This work was supported by the Russian Foundation for Basic Research and Moscow city Government according to the research project № 19-33-70001.

FLUORESCENT CHEMOSENSOR FOR MERCURY (II) CATIONS IN AQUEOUS SOLUTION  
BASED ON 4-(ACETYL) AMINO-1,8-NAPHTHALIMIDE DERIVATIVE CONTAINING  
N-PHENYLAZADITHIA-15-CROWN-5-ETHER RECEPTOR

*Polyakova A.S.*<sup>1,2</sup>, *Panchenko P.A.*<sup>1,2</sup>, *Fedorov Yu. V.*<sup>1</sup>, *Fedorova O.A.*<sup>1,2</sup>

<sup>1</sup>A. N. Nesmeyanov Institute of Organoelement Compounds, Russian Academy of Sciences, Moscow, Russia

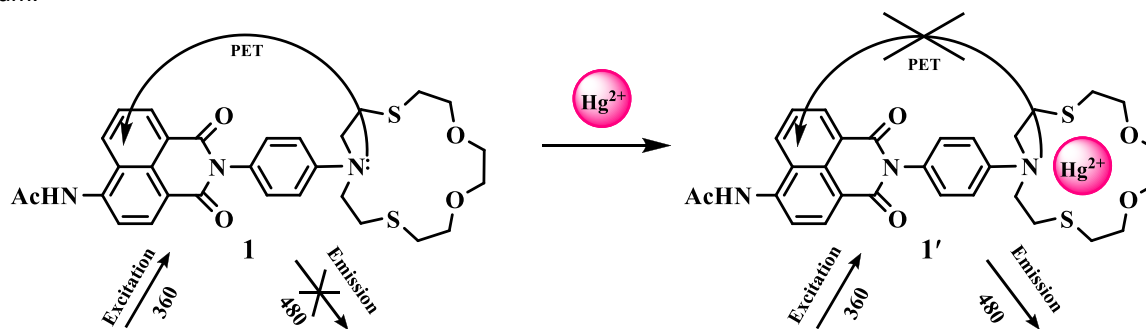
<sup>2</sup>D. I. Mendeleev University of Chemical Technology of Russia, Moscow, Russia

Phd Student

[ania.poliakova@mail.ru](mailto:ania.poliakova@mail.ru)

One of the urgent tasks of chemical analysis is the detection of metal cations in environmental objects and biological systems. Great progress in this direction has been achieved thanks to the creation of optical chemosensors, the molecules of which contain two important parts: 1) a receptor capable of selectively binding to a substrate, 2) a signal fragment that changes its spectral characteristics during complex formation [1]. Often, 1,8-naphthalimide derivatives act as a signal element, which intensively absorbs and fluoresces in the visible part of the spectrum, and have high thermal and light stability.

In this work, the synthesis of Compound **1** contains azadithiacrown ether group as a receptor unit, (Figure 1), which has an affinity for heavy metal cations ( $\text{Hg}^{2+}$ ) [2]. In turn, the signal fragment was performed by 4-(acetyl)amino-1,8-naphthalimide, which intensively absorbs and fluoresces in the visible region of the spectrum.



**Figure 1.**

The resulting compound exhibits low-intensity fluorescence due to the process of electron transfer from the N-aryl group to the naphthalimide residue in the photoexcited state, which is confirmed by the data of quantum-chemical calculations by the PM6 method. The binding of  $\text{Hg}^{2+}$  in an aqueous acetate buffer solution at pH 6.0 is accompanied by the formation of a 1: 1 metal - ligand complex, in which electron transfer is suppressed, that leads to the fluorescence enhancement. The observed spectral changes were used to determine the value of the stability constant of the complex  $K$  ( $\log K = 6.51 \pm 0.03$ ). The found detection limit of  $\text{Hg}^{2+}$  using the obtained sensor (28 nmol / L) has been found to be quite close the MPC for mercury in drinking water. The study of the selectivity of complexation showed that the presence of cations  $\text{Cu}^{2+}$ ,  $\text{Zn}^{2+}$ ,  $\text{Ni}^{2+}$ ,  $\text{Pb}^{2+}$ ,  $\text{Cd}^{2+}$ ,  $\text{Ca}^{2+}$ ,  $\text{Mg}^{2+}$ ,  $\text{Fe}^{2+}$  does not interfere with the determination of  $\text{Hg}^{2+}$ . The presented results indicate that the obtained chemosensor is promising as a selective and highly sensitive fluorescent reagent for  $\text{Hg}^{2+}$  ions in an aqueous solution.

### References

- [1] Panchenko P. A., Polyakova A.S., Fedorov Yu.V., Fedorova O.A. *Mendeleev Commun.* **2019**, 29, 155–157  
[2] Berdnikova D.V., Fedorov Yu. V., Fedorova O. A., Jonusauskas G. *Dyes and Pigments.* **2018**, 151, 227–232

Acknowledgements. The work was supported by the Russian Science Foundation (project no. 20-73-10186).

## BIS- $\alpha$ -HYDROXYPHOSPHINOXIDES: SYNTHESIS AND ESTERIFICATION

*Ponomareva N.A., Mukhina Yu.V., Pushkina K.A, Aleksandrova E.A., Trishin Yu. G.*

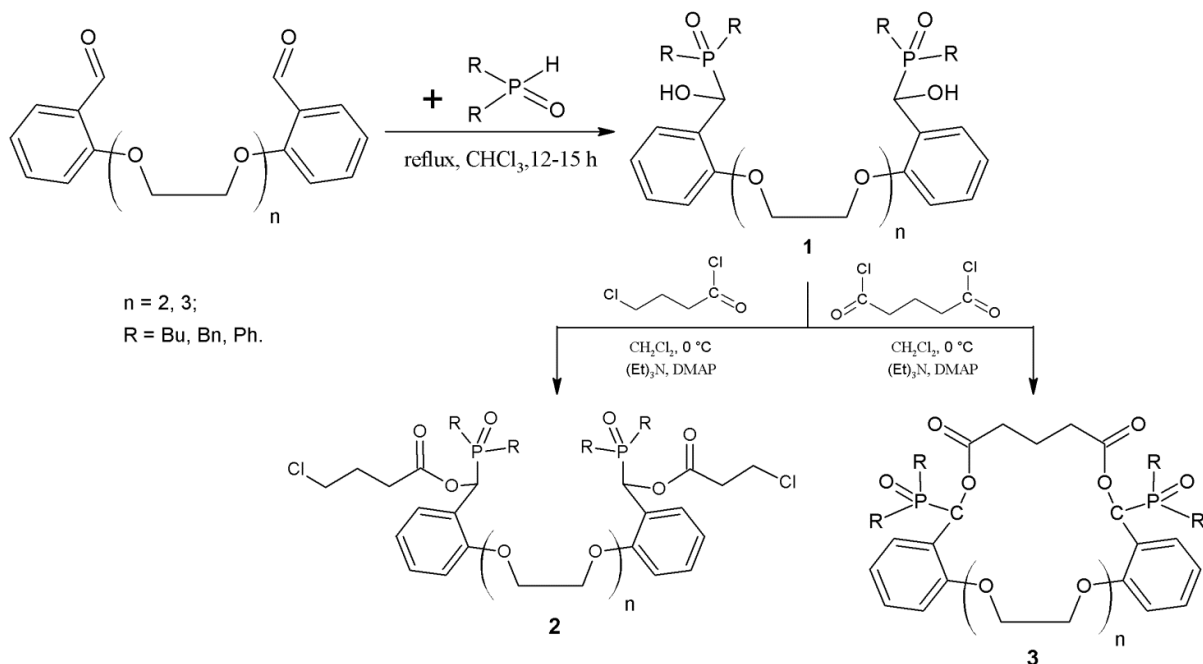
Saint Petersburg State University of Industrial Technologies and Design  
Higher School of Technology and Energy, Saint Petersburg, Russia  
Student

[natalya.ponomareva.99@mail.ru](mailto:natalya.ponomareva.99@mail.ru)

The uniqueness of the chemical nature of  $\alpha$ -hydroxyphosphoryl compounds, with  $=P(O)-CH(OH)-$  groups, makes it possible to use them as inhibitors of enzymes, antibacterial, antitumor, antiviral agents [1], herbicides and insecticides [2]. Due to their high and often selective extraction ability, they can be used to extract lanthanides, actinides and other transuranic metals (uranium, thorium, zirconium) [3].

Bis- $\alpha$ -hydroxyphosphinoxides, with are organophosphorus compounds with two  $R_2P(O)-CH(OH)-$  groups, belong to understudied substances, although they can be expected to exhibit special biologically active and extraction properties. In addition, they can serve as diol fragments for the synthesis of phosphorus-containing polymers and macrocycles of ligands [4].

In this work, the interaction of secondary phosphinoxides with aromatic dialdehydes is investigated, as a result of which two formylphenyl radicals are linked to each other by an ether spacer, obtained bis- $\alpha$ -hydroxyphosphinoxides **1**. As a result of the esterification of compounds **1** with gamma-chlorobutyric acid chloride in triethylam and dimethylaminopyridinium, bis-esters **2** were synthesized, phosphorylated macrocyclic esters **3** were obtained under similar conditions.



**Figure 1.** Preparation and esterification of  $\alpha$ -hydroxyalkylphosphine oxides

### References

- [1] Serkan E., Mehmet G., Ayhan Sitki D. Turk. J. Chem. **2014**, 38, 164 – 171
- [2] Shibuya S., Kumiai Chem. **1996**, 61, 1-11
- [3] Krea M., Khalaf H., Hydrometallurgy **2000**, 58, 215-225
- [4] Zehuai M., Yinjun W., Xi M. Phosphorus, Sulfur Silicon Relat. Elem. **2021**, 2, 195–19



## CHOLINE DERIVATIVES AS SUPRAMOLECULAR CATALYSTS OF RADICAL DECOMPOSITION OF HYDROPEROXIDES

*Potapova N.V., Kasaikina O.T.*

N.N. Semenov Federal Research Center for Chemical Physics Russian Academy of Sciences, Moscow, Russia  
Young scientist  
[Pot.natalia2010@yandex.ru](mailto:Pot.natalia2010@yandex.ru)

Choline derivatives, including the quaternary ammonium cation ( $R_4N^+$ ), play an important role in living organisms, animals and plants. They can be divided into those containing quaternary ammonium cation (choline, acetylcholine and L-carnitine) and zwitterions in which the quaternary ammonium cation is zwitterionically bound to a phosphate group (gliatilin, citicoline, and phosphatidylcholine).

Previously it was found that acetylcholine, when dispersed in a hydrocarbon medium together with hydroperoxides (ROOH) forms microaggregates ACh-ROOH, and accelerates the decomposition of ROOH with the formation of radicals. The object of our study was the study of the catalytic action of choline derivatives in mixed aggregates.

The catalytic effect of water-soluble ACh, Ch, and LCr on the radical decomposition of ROOH is manifested in a hydrophobic medium - in organic solvents or in an adsorbed state. It was found that L-carnitine and choline, like acetylcholine, form mixed aggregates with ROOH, in which they accelerate the decomposition of hydroperoxide into radicals.

Gliatilin, citicoline, and phosphatidylcholine, in which the  $R_4N^+$  cation is zwitterionic to phosphate groups, do not affect the decomposition of ROOH. In a neutral phosphatidylcholine (PC) molecule, the choline cation is linked by a zwitterionic bond to a phosphate ion, but when interacting with  $Ca^{2+}$  or  $Mg^{2+}$  salts, the choline fragment can be released converting PC into a quaternary ammonium compound. This system PC-ROOH, like ACh, is capable of catalyzing the radical decomposition of hydroperoxides and initiating radical-chain processes.

Acknowledgements. This work was supported by the Russian Foundation for Basic Research 20-03-00753

## TREATMENT OF LUNG CANCER CELL CONTAMINATION

*Pozharskii A.A., Sagaidak A.V.*

Saint-Petersburg State Institute of Technology, Saint Petersburg, Russia

Student

[a.a.pozharskiy@gmail.com](mailto:a.a.pozharskiy@gmail.com)

One of the main factors for obtaining reliable results when conducting studies in cell lines is the quality of the culture since contamination leads to a change in the structure of cells and their functioning [1]. In this regard, regular control of the cell purity is an important condition for working with cultures, including those obtained from official cell banks. In the case of contamination detection, qualified treatment of cellular objects becomes the priority issue.

In the case of human cell cultures, the contaminants are fungi, viruses, bacteria and protozoa. The most common contaminant is mycoplasma, bacteria that do not have the cell wall. It is noted that in cells infected with mycoplasma the proliferation rate changes, metabolism is disturbed, in some cases vacuolization and granularity of cells is observed, the formation of multinucleated cells is possible. During microscopic examination, mycoplasma is visualized as small moving round objects in the intercellular space.

In this work, we considered the H1299 human lung adenocarcinoma cell culture, in which a contamination was revealed during its cultivation. Determination of the contaminant nature was provided by staining the cells with the Hoechst 33342 nuclear fluorochrome, followed by the use of the Operetta CLS high-content analysis system [2]. As a result of the analysis of the contaminant morphology, an assumption about its bacterial nature was made. The contaminant was significantly smaller than eukaryotic cells, and its effect on the cells corresponded to the signs of mycoplasma contamination.

Several ways of the cell treatment using antibiotics of various groups, such as penicillin, amphotericin B, gentamicin, and ciprofloxacin were used to decontaminate the strain; however, a significant reduction in the infection was observed only under the treatment with fluoroquinolone drugs. The effect of the drug was quantitatively analyzed using optical microscopy when cells were cultured in a 6-well plate on a RPMI-1640 medium containing 10, 15, 20, 25, 30, 35 µg/mL of ciprofloxacin for 12 days [3]. Based on the combined assessment of such parameters as the morphology and viability of cells, as well as the achievement of the decontamination effect, the effective concentration of the drug was concluded.

### References

- [1] Romanova A., Sagaidak A., Lvova M., Grigoreva T. *Development of a high-content analysis procedure for quantitative determination of proapoptotic ability of small molecule compounds*. **2020**, 55, 58-61
- [2] Young L., Sung J., Stacey G., Masters J. *Detection of mycoplasma in cell cultures*. **2010**, 5(5), 929-934
- [3] Harlin H., Gajewski T. *Diagnosis and treatment of mycoplasma-contaminated cell cultures*. **2008**, appendix 3.

Acknowledgements. This work was supported by Russian Foundation for Basic Research (project no. 20-33-70250).

# SYNTHESIS AND BIOLOGICAL ACTIVITY OF A PYRIDOXINE DERIVATIVE WITH NO-DONOR PROPERTIES

*Prikhodchenko T.R.*<sup>1,2</sup>, *Balakina A.A.*<sup>1</sup>, *Amozova V.I.*<sup>1,3</sup>, *Mumyatova V.A.*<sup>1</sup>, *Stupina T.S.*<sup>1</sup>,  
*Neganova M.E.*<sup>4</sup>, *Yakushev I.A.*<sup>5,6</sup>, *Kornev A.B.*<sup>1</sup>, *Gadomsky S.Ya.*<sup>1</sup>, *Fedorov B.S.*<sup>1</sup>, *Mishchenko D.V.*<sup>1,2</sup>

<sup>1</sup>Institute of Problems of Chemical Physics RAS, Chernogolovka, Russia

<sup>2</sup>Moscow Region State University, Mytishchi, Russia

<sup>3</sup>Lomonosov Moscow State University, Moscow, Russia

<sup>4</sup>Institute of Physiologically Active Compounds RAS, Chernogolovka, Russia

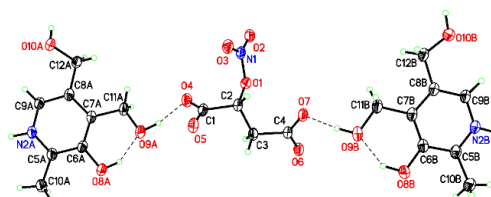
<sup>5</sup>Kurnakov Institute of General and Inorganic Chemistry RAS, Moscow, Russia

<sup>6</sup>National Research Center "Kurchatov Institute", Moscow, Russia

PhD student

[t\\_prikhodchenko@list.ru](mailto:t_prikhodchenko@list.ru)

It is known that high doses of anticancer drugs can cause serious toxic side effects that affect normal organs and tissues. With the development and progression of malignant tumors, the generation of reactive oxygen species (ROS) is activated and the processes of lipid peroxidation (LPO) and oxidative stress are enhanced. Vitamin B6 (also known as pyridoxine) is a coenzyme involved in over 100 metabolic reactions of amino acids, glucose, lipids and DNA and may play an important role in the antioxidant defense against oxidative stress. Due to the fact that cytostatic agents do not possess selective activity, the search for compounds for adjuvant chemotherapy of tumors with antioxidant activity and low toxicity is urgent. The aim of this work was to synthesize and study the cytotoxic and antioxidant properties of the new hybrid compound B6NO. The structure and purity of B6NO was analyzed by elemental analysis, IR and NMR spectroscopy. For biological studies, we used normal and tumor cell cultures, as well as a homogenate of the rat brain. The animals were kept under standard conditions USU Nursery and vivarium IPCP RAS. Intracellular accumulation of ROS under conditions of oxidative stress induction was determined using the fluorescent dye DCFHDA. To determine the level of intracellular NO accumulation, the DAF-FM DA dye was used. The study of the cytotoxicity was carried out using the MTT test. The iron chelating activity was determined by the ability to compete with ferrozine for binding with Fe<sup>2+</sup> ions. The ability of the compounds to influence the process of spontaneous and initiated LPO was assessed by the change in the accumulation of malondialdehyde. A new compound bis-(4,5-hydroxymethyl-2-methyl-3-hydroxy) pyridinium salt of 2-nitroso-butane-1,4-diacid (B6NO) was synthesized. The B6NO synthesis scheme consists of two parallel processes (namely, preparation of pyridoxine from the corresponding hydrochloride and nitration of malic acid to an ester), combined at the final stage of salt preparation. The structure of B6NO in the crystalline state (Fig. 1) was established using X-ray diffraction analysis using synchrotron radiation on the X-ray beam of the Belok station of the Kurchatov Synchrotron Radiation Center at the National Research Center "Kurchatov Institute" (Moscow, Russian Federation).



**Figure 1.** Molecular structure of bis-(4,5-hydroxymethyl-2-methyl-3-hydroxy) pyridinium salt of 2-nitroso-butane-1,4-diacid (B6NO)

It was shown that B6NO exhibits antioxidant properties in the concentration range from 5 to 80  $\mu\text{M}$ , while reducing the ROS content to the control level in normal Vero cells. In addition, the hybrid compound B6NO exhibits antioxidant properties at lower concentrations compared to the reference drug vitamin B6 (pyridoxine). It was shown that B6NO chelates iron ions by 94%, while vitamin B6 in equimolar concentration bound ferrous ions by no more than 10%. It was revealed that the hybrid compound B6NO inhibits LPO processes more effectively than pyridoxine. The accumulation of intracellular NO by both B6NO and vitamin B6 was significantly increased in the Vero normal cell model. In combination with the anticancer drugs doxorubicin and cisplatin, B6NO did not affect its cytotoxicity on normal cells and increased or did not decrease cytotoxicity in experiments on tumor cells. Thus, a new derivative of vitamin B6 has been synthesized and characterized. It was shown that the new hybrid compound B6NO is a low-toxic compound, exhibits antioxidant properties by inhibiting the Fenton reaction, and also reducing the level of ROS intracellular accumulation under conditions of oxidative stress induction. Modification of vitamin B6 with nitro malic acid enhances its antioxidant and NO-donating properties. These results indicate the high potential of B6NO as a promising compound for adjuvant tumor chemotherapy.

Acknowledgements. This work was supported by the Ministry of Education and Science of the Russian Federation, no. AAAA-A19-11092390041-5.

## A NEW APPROACH TO THE STRUCTURAL MODIFICATION OF INDOLINE SPIROPYRANS

*Pugachev A.D.*<sup>1</sup>, *Ozhogin I.V.*<sup>1</sup>, *Kozlenko A.S.*<sup>1</sup>, *Lukyanova M.B.*<sup>1</sup>, *Borodkin G.S.*<sup>1</sup>, *Rostovtseva I.A.*<sup>1</sup>,  
*Makarova N.I.*<sup>1</sup>, *Gogoleva S.D.*<sup>3</sup>, *Dorogan I.V.*<sup>1</sup>, *Tkachev V.V.*<sup>2</sup>, *Lukyanov B.S.*<sup>1</sup>

<sup>1</sup>Southern Federal University, Rostov-on-Don, Russia

<sup>2</sup>Institute of Problems of Chemical Physics of RAS, Chernogolovka, Russia

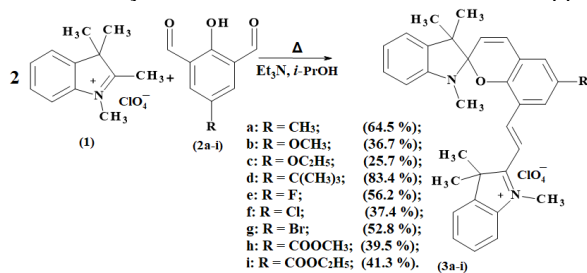
<sup>3</sup>Grodno State University, Grodno, Republic of Belarus

Young Scientist

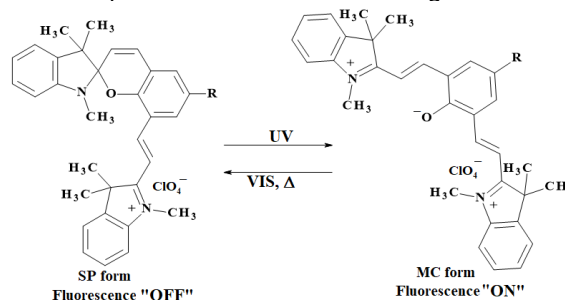
[artem\\_d\\_pugachev@mail.ru](mailto:artem_d_pugachev@mail.ru)

Spiropyrans (SP) are well-known representatives of the class of dynamic organic compounds capable of a dramatic properties change under electromagnetic irradiation [1]. Photochromic SPs can be used as easily tunable molecular switches in various advanced branches of science and technology [2]. For the use of photochromic molecules as fluorescent probes it is extremely important that these compounds have controlled fluorescence and absorption in the biological window (650 - 1350 nm), as well as high lifetime values for photoinduced isomer. The target spirocyclic compounds were obtained by one-pot synthesis (**Figure 1**). The structure was confirmed by IR and NMR spectroscopy and single crystal X-ray analysis.

Due to an increased conjugation chain compared to another indoline SPs and structural similarity with cyanine dyes, whose derivatives are actively used in medical practice as fluorescent probes for fluorescence guided surgery [3], the merocyanine (MC) isomers of the obtained compounds are characterized by the photoluminescence emission maxima up to 790 nm (**3e**), the absorption maxima up to 738 nm (**3e**) and the lifetimes up to 4516.5 seconds (**3h**). The photoisomerization scheme for compounds (**3a-i**) and changes of their fluorescence properties shown below (**Figure 2**). To understand the nature of the obtained spectral characteristics, quantum chemical studies were carried out for the most stable conformers. The data obtained using TD DFT method indicate that the photoisomerization of cationic spiropyrans (**3e**), (**3f**) and (**3g**) leads to the formation of MCs with at least one *trans-trans-trans* fragment of vinyl-3*H*-indolium, which approximates them to a cyanine-like structure and causes the appearance of absorption bands in the near-IR region.



**Figure 1.** Synthesis of with conjugated vinyl-3*H*-indolium fragment



**Figure 2.** Photoisomerization of the SP (**3a-i**) and changes of their fluorescence properties.

As a result, a new approach to the structural modification of indoline spiropyrans consisting in the introduction of conjugated vinyl-3*H*-indolium fragment into the molecule has allowed to obtain promising for use as fluorescent probes for bioimaging photochromic compounds.

### References

- [1] Szymanski W., et al. *Chem. Rev.* **2013**, 113, 6114–6178
- [2] Klajn R. *Chem. Soc. Rev.* **2014**, 43, 148–184.
- [3] Alanderet J. T., et al. *Int. J. Biomed. Imaging* **2012**, article number: 940585

### Acknowledgements.

This work was supported by Russian Foundation for Basic Research (project No 20-53-04023).

*Gogoleva S.D.* thanks Belorussian Republican Foundation for Fundamental Research (project F21RM-134)

SYNTHESIS OF ACETYLENIC 1,2,4-OXADIAZOLES AND THEIR REACTIONS  
IN SUPERACID TfOH (CF<sub>3</sub>SO<sub>3</sub>H)

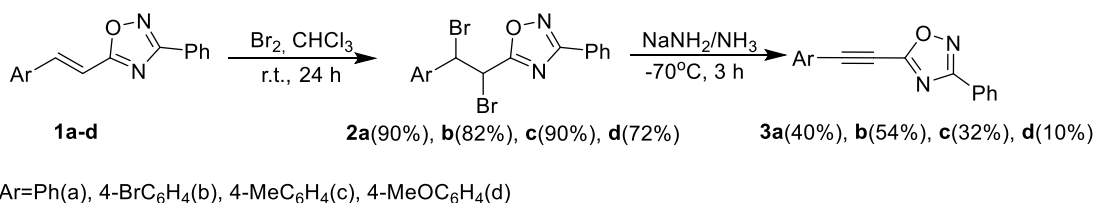
*Puzanov A.I.<sup>1</sup>, Ryabukhin D.S.<sup>1</sup>, Zalivatskaya A.S.<sup>1</sup>, Zakusilo D.N.<sup>1</sup>, Vasilyev A.V.<sup>1</sup>*

<sup>1</sup>Saint Petersburg State Forest Technical University, Saint Petersburg, Russia  
Student

[apuzanov21@mail.ru](mailto:apuzanov21@mail.ru)

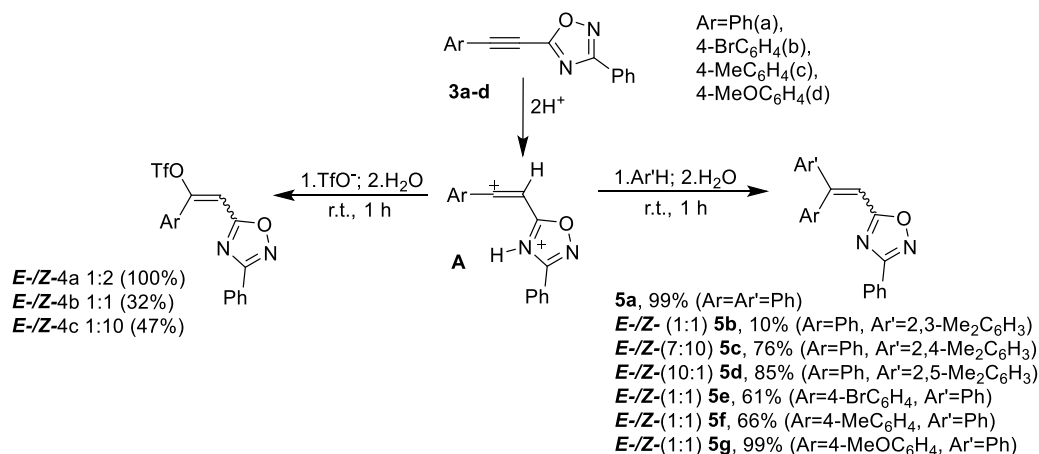
In recent years, significant advances in the development of new medicines based on 1,2,4-oxadiazoles have been made. They are ones of the most important objects of study in the field of medicinal chemistry and biotechnology [1]. Therefore, much attention is paid to the synthesis of new oxadiazoles derivatives. Previously, conjugated acetylenic derivatives of 1,2,4-oxadiazole at the C<sup>5</sup> position were not obtained [2]. The purpose of this work was to develop method for the synthesis of new compounds based on the transformations of acetylenic derivatives of 1,2,4-oxadiazole under conditions of superelectrophilic activation by Bronsted superacid TfOH (CF<sub>3</sub>SO<sub>3</sub>H).

The synthesis of acetylenic derivatives **3a-d** is based on the bromination of 5-arylethenyl-1,2,4-oxadiazoles **1a-d**, followed by didehydrobromination of the obtained dibromo derivatives **2a-d** in the NaNH<sub>2</sub>-NH<sub>3</sub>(liq.) system (Scheme 1). In the latter reaction, other bases were also tested, such as KOH, BuLi, t-BuOK, LiN(i-Pr)<sub>2</sub>, but they did not lead to the formation of the desired acetylene derivatives.



**Scheme 1.**

Next, we studied the transformations of compounds **3a-d** under electrophilic activation conditions by Bronsted superacid TfOH. It was found that substance **3a-c** in trifluoromethanesulfonic acid CF<sub>3</sub>SO<sub>3</sub>H (TfOH) (r.t., 1 h) gave *E/Z*-vinyl triflates **4a-c**. Reactions of compound **3a-d** with arenes in (TfOH) (r.t., 1 h) furnish the products of hydroarylation of the acetylene bond **5a-d**. These transformations can occur through an intermediate generation of reactive dications **A**.



**Scheme 2.**  
**References**

- [1] Biernacki K., Daško M., Ciupak O., Kubiński K., Rachon J., Demkowicz S. *Novel 1,2,4-Oxadiazole Derivatives in Drug Discovery Pharmaceuticals*. **2020**, *13* (6), 111.
- [2] Claisse, J. A., Foxton, M. W., Gregory, G. I., Sheppard, A. H., Tiley, E. P., Warburton, W. K., & Wilson, M. J. *Journal of the Chemical Society, Perkin Transactions* **1973**, *1*, 2241.

Acknowledgements. This work was supported by Russian Foundation for Basic Research (project No 20-03-00074).

CYTOTOXIC ACTIVITY OF SOME ESTERS OF 1,2-DICHLORMETHYL BENZENE

Raskil'dina G.Z.<sup>1</sup>, Borisova Yu.G.<sup>1</sup>, D.V. Ishmetova<sup>2</sup>, U.Sh. Kuzmina<sup>2</sup>, L.Kh. Zaripova<sup>2</sup>, S.S. Zlotskii<sup>1</sup>

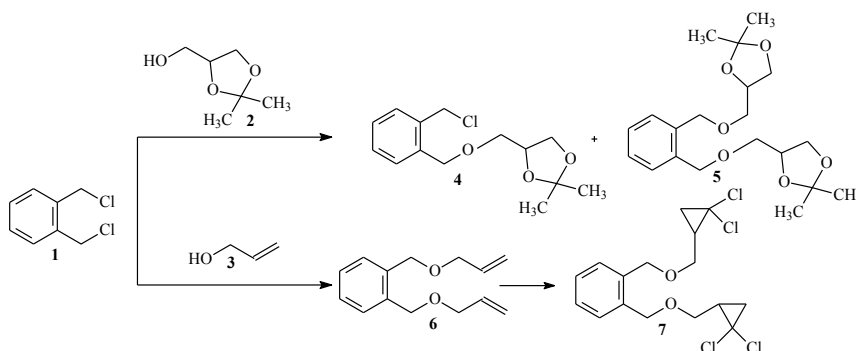
<sup>1</sup>Ufa State Petroleum Technological University, Ufa, Russia

<sup>2</sup>Institute of Biochemistry and Genetics of the Ufa Federal Research Centre of the Russian Academy of Sciences, Ufa, Russia

Young scientist

[yulianna\\_borisova@mail.ru](mailto:yulianna_borisova@mail.ru)

Esters containing *gem*-dichlorocyclopropane and / or 1,3-dioxacycloalkane cycles have herbicidal, antioxidant, antimicrobial and antiviral properties [1-4]. We have previously found that the cytotoxic activity against tumor cells exhibit compounds whose molecules present cycloacetal and *gem*-dichlorocyclopropane fragments [5]. Using 1,2-dichloromethylbenzene **1** (see figure), new ethers **4**, **5** and **7** were obtained to further determine their cytotoxicity *in vitro*.



**Figure.** Scheme of synthesis of esters of 1,2-dichloromethylbenzene.

When dichloride **1** interacts with 2,2-dimethyl-4-hydroxymethyl-1,3-dioxolane **2**, the corresponding mono-4 and diesters **5** are formed, while with allyl alcohol **3** only monoester **6** is formed. From diester **6** according to the well-known method [5] dichlorocyclopropane **7** was obtained at a temperature of 10°C in the presence of chloroform, alkali and catamine AB.

As a result of the biological study, the cytotoxic properties of compounds **5** and **7** were established only in relation to the lines of tumor origin SH-SY5Y, HepG2 and A549 (see Table). High sensitivity of SH-SY5Y and MCF-7 cells to negative action of compound **4** was revealed. Thus, the cytotoxic activity of esters of 1,2-dichloromethylbenzene was studied, the specificity of their toxic action was determined.

**Table.** Cytotoxicity of compounds *in vitro*.

Compound	IC <sub>50</sub> , μM				
	Hek293	SH-SY5Y	HepG2	MCF-7	A549
<b>4</b>	51.80 ± 0.99	6.45 ± 1.24**	72.65 ± 5.64**	15.42 ± 0.58**	22.12 ± 0.99**
<b>5</b>	>100	33.21 ± 1.34**	72.73 ± 1.44**	>100	66.64 ± 3.17**
<b>7</b>	>100	90.90 ± 5.78**	81.04 ± 1.72**	>100	47.51 ± 1.44**

\*\* -  $p \leq 0.001$  relative to IC<sub>50</sub> values in cells of normal origin HEK293 (ANOVA, Dunnett's test).

**References**

- [1] Yakovenko Eu.A., Raskil'dina G.Z., Mryasova L.M., Zlotsky S.S. *Chemistry and Technology of Organic Substances*, **2019**, 3, 11, 4.
- [2] Raskil'dina G.Z., Kuzmina U.Sh., Dzhumaev Sh.Sh., Borisova Yu.G., Ishmetova D.V., Vakhitova Yu.V., Zlotskii S.S. *Izvestiya Akademii Nauk. Seriya Khimicheskaya*. **2021**, 3, 1-4.
- [3] Ovsyannikova M.N., Vol'eva V.B., Belostotskaya I.S. *Pharm Chem*. **2013**, 47, 142–145.
- [4] Raskil'dina G.Z., Borisova Yu.G., Zlotskii S.S. *Pet. Chem*, **2017**, 57, 278-283.
- [5] Raskil'dina G.Z., Kuz'mina U.S., Borisova Y.G., Zlotskii S.S. *Pharm Chem*, **2020**, 54, 909-913,

Acknowledgements. The research was carried out with the financial support of a grant from the President of the Russian Federation for state support of young Russian scientists - candidates of sciences and doctors of sciences (No. MK-1689.2020.3) and in accordance with the plan of research work of IBG UFRC RAS.

PROTIC IONIC LIQUIDS: APPLICATION IN DONOR-ACCEPTOR  
CYCLOPROPANE RING-OPENING WITH AZIDE ION

*Ratmanova N.K.*<sup>1</sup>, *Andreev I.A.*<sup>1,2</sup>, *Boichenko M.A.*<sup>3</sup>, *Ivanova O.A.*<sup>2,3</sup>, *Trushkov I.V.*<sup>1,2</sup>

<sup>1</sup>Dmitry Rogachev National Medical Research Center of Pediatric Hematology, Oncology and Immunology, Moscow, Russia

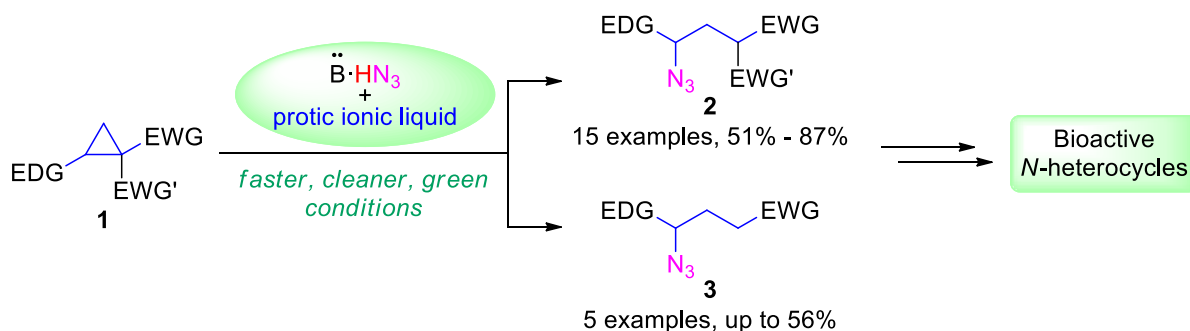
<sup>2</sup>N.D. Zelinsky Institute of Organic Chemistry, Russian Academy of Sciences, Moscow, Russia

<sup>3</sup>M.V. Lomonosov Moscow State University, Department of Chemistry, Moscow, Russia  
Young Scientist

[nina.ratmanova@fccho-moscow.ru](mailto:nina.ratmanova@fccho-moscow.ru)

The development of effective synthetic methodologies, which ensure the chemo-, regio-, and stereoselectivity of the reaction, and follow the concepts of “atom economy”, “sustainable chemistry”, and “green chemistry”, remains highly demanded. One of the possible solutions to satisfy the above-mentioned requirements is the use of protic ionic liquids (PILs) – low-melting salts of Brønsted acid and base. Recently, we proposed a novel concept of the triple role of PILs with nucleophilic anions in organic synthesis, i.e., a solvent, an acid initiator, and a source of a nucleophile, and demonstrated the efficiency of this concept in the ring-opening of donor-acceptor (D-A) cyclopropanes using thiocyanate-based PILs [1].

We modified this strategy to perform ring-opening of D-A cyclopropanes **1** with azide ion in protic ionic liquids. Salts of hydrazoic acid with the appropriate Brønsted base were employed as a source of azide ion. PIL media were applied as solvents and catalysts. Thorough optimization of the reaction conditions led to the elaboration of general procedures, which furnished various (2-azido-2-arylethyl)malonates **2** or the corresponding dealkoxycarbonylation products 4-azido-4-arylbutyrates **3** depending on the judicious choice of the PIL media. It was also demonstrated that PILs could be regenerated after the reaction and used repeatedly.



**Figure 1.** D–A cyclopropanes **1** ring-opening with azide ion in PIL media.

The developed procedures can be used for the synthesis of a wide variety of diverse bioactive azaheterocyclic compounds derived from azide precursors.

#### References

[1] Andreev I.A., Ratmanova N.K., Augustin A.U., Ivanova O.A., Levina I.I., Khurstalev V.N., Werz D.B., Trushkov I.V. *Angew. Chem. Int. Ed.* **2021**, *60*, 7927–7934

Acknowledgements. This work was supported by the Russian Foundation for Basic Research (project No 20-33-70014).

# TRIARYLAMINE-BASED MATERIALS AS PROMISING CATHOLYTES FOR NON-AQUEOUS REDOX FLOW BATTERIES

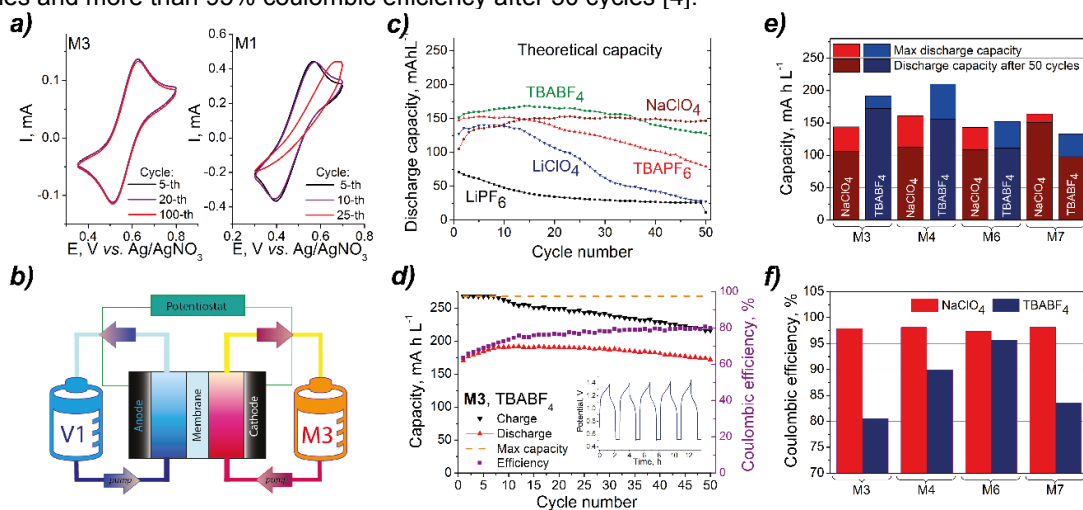
*Romadina E.I.<sup>1</sup>, Stevenson K.J.<sup>1</sup>*

<sup>1</sup> Skolkovo Institute of Science and Technology, Bolshoy Boulevard 30, bld. 1, Moscow, Russia  
PhD Student  
[elena.romadina@skoltech.ru](mailto:elena.romadina@skoltech.ru)

The rapid growth of the role of renewable energy sources dictates new requirements for the efficiency, stability and scales of electrochemical energy storage devices for stationary applications [1]. Today the Redox Flow Batteries (RFB) are considered to be the most perspective technology for power grid application [2].

Within the framework of the current project, we implemented a comprehensive study for a large group of novel highly soluble organic materials based on aromatic amines with general formulas of  $NPh_3R_nBr_m$  (**M1-M4**) and  $N_2Ph_5R_nBr_m$  (**M5-M7**) where  $R=-(OCH_2CH_2)_2-OCH_3$ . All the compounds demonstrated high solubility in acetonitrile ( $>2.2M$ ), what makes them perspective for non-aqueous RFBs application [3].

Electrochemical studies of all the materials were performed by cycling voltammetry. All components demonstrated one or two quasi-reversible electron transition processes with redox potential up to 0.6 V vs. Ag/AgNO<sub>3</sub> electrode, what makes them perspective for the investigation in the RFBs as catholyte materials. Commonly known compound anolyte compound butylviologen perchlorate (-0.75V vs. Ag/AgNO<sub>3</sub>, ~1.15 V battery voltage) was chosen as the redox pair. On the first step, the selection of the most appropriate electrolyte was performed. It was shown that the usage of electrolytes contained lithium cations (Li<sup>+</sup>) and hexafluorophosphate anions (PF<sub>6</sub><sup>-</sup>) leads to fast decreasing of all the parameters of the RFBs, whereas the usage of the tetrabutylammonium tetrafluoroborate (TBABF<sub>4</sub>) and NaClO<sub>4</sub> produces the stable characteristics. After that, all synthesized compounds were tested in laboratory prototype of the RFB with NaClO<sub>4</sub> and TBABF<sub>4</sub> supporting electrolytes. It was shown, that the most promising systems are capable to exhibit 65% of maximum capacities and more than 95% coulombic efficiency after 50 cycles [4].



**Figure 1** (a) Continuous voltammetric cycling of 3mM **M1** and **M3** in 0.1 M TBABF<sub>4</sub>/MeCN solution; (b) Schematic diagram of assembled RFB device; (c) Dependence of the discharge capacity of the cycle number for 10 mM redox-flow cells containing **M3** and **V1** for various background electrolytes; (d) Electrochemical performance of the RFB with 10 mM **M3/V1** 0.1 M TBABF<sub>4</sub>; (e) Maximal discharge capacities, discharge capacities after 50 cycles, and (f) Maximal Coulombic Efficiencies of 10mM **M3/V1**, **M4/V1**, **M6/V1**, **M7/V1** pairs in RFB devices with 0.1M NaClO<sub>4</sub> or 0.1M TBABF<sub>4</sub> supporting electrolytes.

To summarize, triarylamine-based molecules establish themselves attractive materials for future research: high redox potential, solubility, fast diffusion opens promising future directions for their usage as organic cathodic material for non-aqueous RFBs.

## References

- [1] Panwar N., Kaushik, S., Kothari S. *Renewable and Sustainable Energy Reviews* **2011**, 15 (3), 1513-1524.
- [2] Placke T., Heckmann A., Schmich, R., Meister P., Beltrop K., Winter, M. *Joule* **2018**, 2 (12), 2528-2550.
- [3] Winsberg J., Hagemann T., Janoschka T., Hager M., Schubert U. *Angew. Chem. Int. Ed.* **2017**, 56 (3), 686-711.
- [4] Romadina E., Volodin I., Stevenson K., Troshin P. *JMC-A*, **2021**, 9, 8303-8307

Acknowledgements. Romadina Elena acknowledges the support provided by Haldor Topsøe A/S Scholarship 2021.



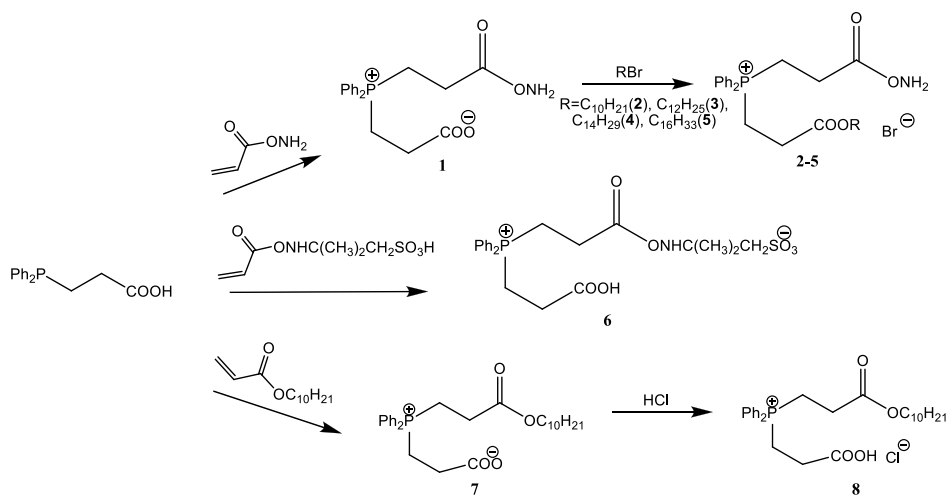
## NEW BIOLOGICAL ACTIVE PHOSPHONIUM SALTS BASED ON TERTIARY PHOSPHINES

*Romanov S.R.*<sup>1</sup>, *Moryasheva A.D.*<sup>1</sup>, *Padenko A.V.*<sup>1</sup>, *Nafikova A.V.*<sup>1</sup>, *Shulaeva M.P.*<sup>2</sup>, *Pozdeev O.K.*<sup>2</sup>,  
*Bakhtiyarova Yu.V.*<sup>1</sup>, *Galkina I.V.*<sup>1</sup>

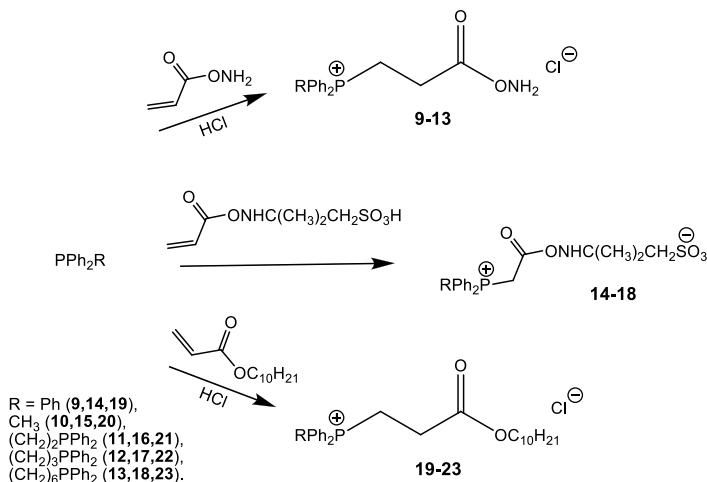
<sup>1</sup>Kazan Federal University, Kazan, Russia  
<sup>2</sup>Kazan State Medical Academy, Kazan, Russia  
PhD Student

[Semyonromanov@yandex.ru](mailto:Semyonromanov@yandex.ru)

Previously we described the synthesis of new biologically active phosphonium salts 2-5 and sulfonate betaine 6 based on 3-(diphenylphosphino)propionic acid (figure 1) [1]. In the framework of this work we obtained new quaternary phosphonium salts on the basis of another tertiary phosphines and electron-deficient alkenes (figure 2).



**Figure 1.** 3-(diphenylphosphino)propionic acid in reactions with electron-deficient alkenes



**Figure 2.** Tertiary phosphines in reactions with electron-deficient alkenes

All new substances 7-23 demonstrated biological activity against pathogenic and opportunistic microorganisms of humans and animals. Many of them exhibited very high biological activity comparable to that of many commercial drugs.

### References

[1] Yu. V. Bakhtiyarova, M. V. Morozov, S. R. Romanov, R. R. Minnullin, M. P. Shulaeva, O. K. Pozdeev, I. V. Galkina, and V. I. Galkin *Russ. Chem. Bull.* **2020**, 69, 1569-1572

Acknowledgements. This work was funded by the subsidy allocated to Kazan Federal University for the state assignment in the sphere of scientific activities (№ 0671-2020-0063)

## SORPTION OF HEAVY METALS BY PAVLOVIA TREE FROM SOIL

*Romanova M. N., Shimova Y.S.*

Reshetnev Siberian State University of Science and Technology  
Krasnoyarsk, Russian Federation  
Student  
[mariebobko@yandex.ru](mailto:mariebobko@yandex.ru)

One of the main important problems of the environment is the condition of the soil. The soil accumulates pollution from industrial emissions, vehicles, agricultural work. The main problem is the pollution of urbanized soils, the main pollutant of which is heavy metals.

There are conditions for the tendency of soil contamination with heavy metals in Krasnoyarsk. The reason of this is a large number of industrial enterprises, transport, difficult terrain with stagnant air masses. At the same time, Krasnoyarsk is distinguished by a small number of green spaces along the roads, especially plants that are capable of accumulating heavy metals.

In Russia, to assess the state of soil pollution, hygienic standards are used, in which maximum permissible concentrations (MPC) and tentative permissible concentrations (APC) are fixed; as well as background geochemical levels and clarkes of chemical elements in the soil. At the first stage of the study, the MPC indicator was determined for the gross form of individual heavy metals.

5 (five) sampling sites were selected on the territory of Krasnoyarsk, which located near industrial enterprises and characterized by a high workload of machines. Soil samples were taken by the envelope method in accordance with GOST 17.4.3.01-83 directly near the road in June and August [1]. In the samples taken, the content of the following heavy metals was determined: copper, nickel, manganese, lead, zinc, mercury in gross form. Analysis performed on an iCAP inductively coupled plasma mass spectrometer. The results showed that in these samples there is an excess in terms of MPC for copper and lead, some values are at the border of MPC [2-3]. At the same time, during the selection of the soil, the absence of vegetation and a changed granulometric composition were noted.

According to foreign studies the Paulownia tree has the ability to accumulate heavy metals from the soil [4]. The next stage of the study was to study the possibility of using the Paulownia tree for landscaping these territories and assessing its impact on soil restoration. The assessment of the ability of Paulownia to accumulate heavy metals from the soil was carried out using the spectrophotometric method, the qualitative parameters of the soils were assessed using standard methods [5]. All studies were carried out on model soil mixtures.

The results obtained indicate a significant improvement in the quality indicators of soil mixtures, such as biological activity, mechanical composition, acidity, particle size distribution, moisture capacity, as well as a high degree of sorption of heavy metals by Paulownia. So Paulownia can be recommended for planting in especially polluted areas of urbanized areas.

### References

- [1] GOST 17.4.3.01-83 Nature Conservation (SSOP). Soils. General requirements for sampling. 2008, 5.
- [2] Romanova M. N. Khromogin P. V. Study of urbanized soils in Krasnoyarsk. 2020, 3.
- [3] Romanova M. N. Paulownia for bioremediation of urbanized soils. **2020**, 4.
- [4] Dragica Stankovic, Ruzica Igic, Mirjana Sijacic-Nikolic. Contents of the heavy metals nickel and lead in leaves of Paulownia Elongata and Paulownia Fortunei in Serbia. 2009, 827-834.
- [5] Methodical instructions MU 2.1.7.730-99 "Soil, cleaning of populated areas, household and industrial waste, sanitary protection of soil". 1999, 20.

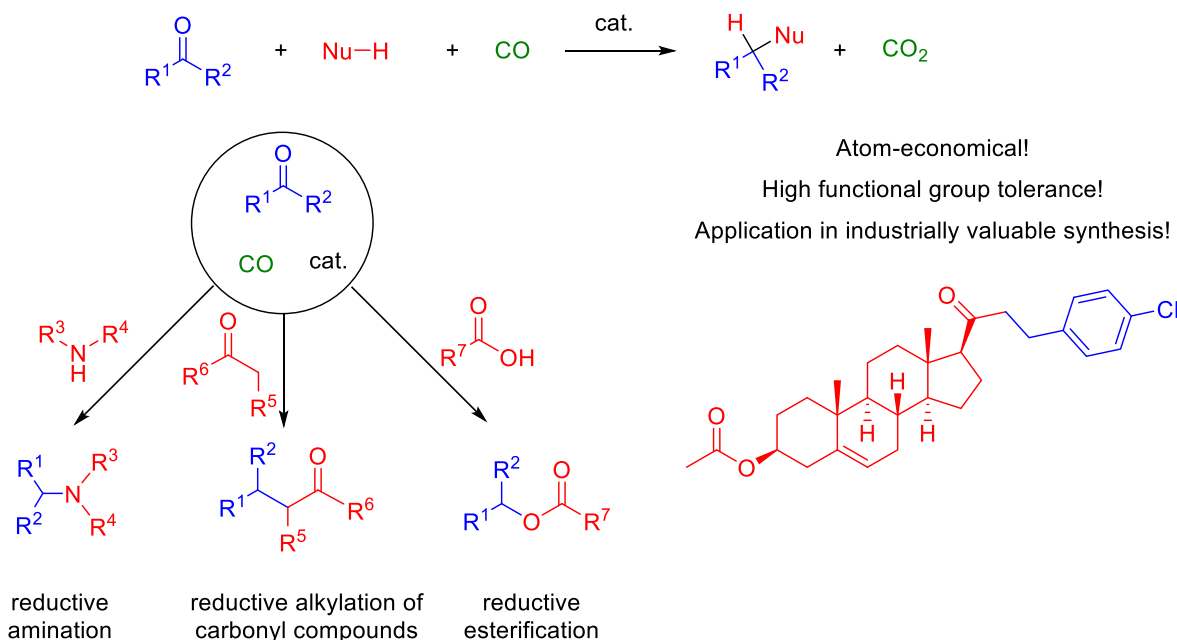
## CARBON MONOXIDE AS A POWERFUL TOOL IN CATALYTIC REDUCTIVE ADDITION

*Runikhina S.A.*<sup>1</sup>, *Ostrovskii V. S.*<sup>1</sup>, *Podyacheva E.*<sup>1</sup>, *Tsygankov A. A.*<sup>1</sup>, *Biriukov K.*<sup>1</sup>, *Kharitonov V. B.*<sup>1</sup>,  
*Afanasyev O. I.*<sup>1</sup>, *Loginov D.*<sup>1</sup>, *Chusov D.*<sup>1</sup>

<sup>1</sup>A.N. Nesmeyanov Institute of Organoelement Compounds of Russian Academy of Sciences, Vavilova St. 28, Moscow, Russia  
Young Scientist  
[runikhina.sofiya@mail.ru](mailto:runikhina.sofiya@mail.ru)

Performance of reductive condensation reactions, such as reductive amination, reductive Knoevenagel condensation, etc., is a substantial task in industrial syntheses. Nevertheless, exploitation of classical reductive agents in such reactions often has its drawbacks, such as low functional-group tolerance or low-atom economy [1].

Herein we introduce one-step reductive addition of hydrogen-containing nucleophiles to carbonyl compounds in an atmosphere of carbon monoxide as an effective approach to the formation of saturated bonds [2-6]. A range of different hydrogen-containing nucleophiles, such as amines, ketones, and even carboxylic acids, were successfully introduced into the reactions. Tolerance to functional groups, such as halogens, C-C unsaturated bonds, ester-groups, was demonstrated. Moreover, the approach found its application in the synthesis of the industrially valuable compound, gamma-Valerolactone, and the approved drug Nabumetone.



**Figure 1.** Reductive addition of hydrogen-containing nucleophiles in atmosphere of an carbon monoxide

### References

- [1] Podyacheva E., Afanasyev O. I., Tsygankov A. A., Makarova M., Chusov D., *Synth.* **2019**, *51*, 2667–2677.
- [2] Runikhina S. A., Arsenov M. A., Kharitonov V. B., Sovdagarova E. R., Chusova O., Nelyubina Y. V., Denisov G. L., Usanov D. L., Chusov D., Loginov D. A., *J. Organomet. Chem.* **2018**, *867*, 106–112
- [3] Runikhina S. A., Usanov D. L., Chizhov A. O., Chusov D., *Org. Lett.* **2018**, *20*, 7856–7859.
- [4] Runikhina S. A., Afanasyev O. I., Biriukov K., Perekalin D. S., Klusmann M., Chusov D., *Chem. – A Eur. J.* **2019**, *25*, 16225–16229
- [5] Ostrovskii V. S., Runikhina S. A., Afanasyev O. I., Chusov D., *European J. Org. Chem.* **2020**, *2020*, 4116–4121
- [6] Kharitonov V. B., Runikhina S. A., Nelyubina Y. V., Muratov D. V., Chusov D., Loginov D., *Chem. – A Eur. J.*, **2021**, Just accepted

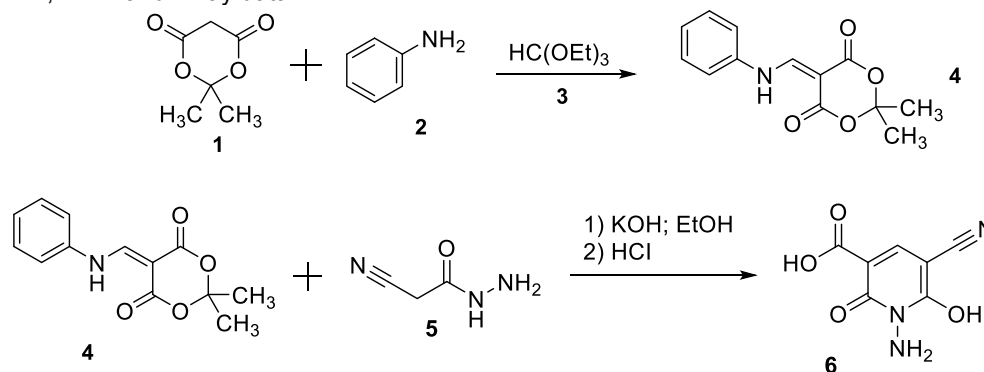
Acknowledgements. This work was supported by the Russian Science Foundation (project No 19-73-20212).

## SYNTHESIS OF 1-AMINO-5-CYANO-2-OXO-1,2-DIHYDRONICOTIC ACID

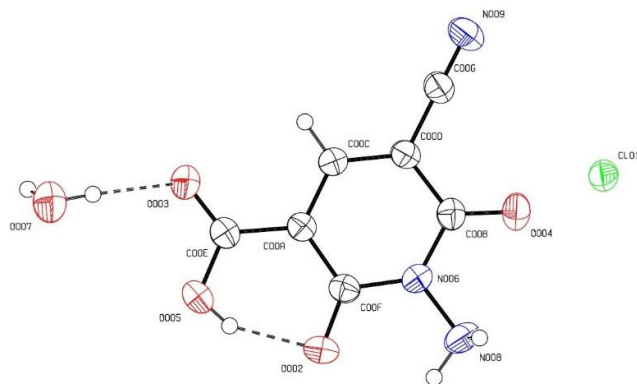
*Russkikh A.A., Dotsenko V.V.*  
 Kuban State University, Krasnodar, Russia  
 Student  
[Alena.russkikh.19988@gmail.com](mailto:Alena.russkikh.19988@gmail.com)

It is known that nicotinic acid (pyridine-3-carboxylic acid, niacin, vitamin PP, vitamin B3) and nicotinic acid derivatives have a wide spectrum of biological activity. Thus, nicotinic acid and nicotinates exhibit hypocholesterolemic, neuroprotective and other effects. The close structural analogue of nicotinic acid, 4-methyl-2-oxo-5-cyano-1,2-dihydropyridine-3-carboxylic acid, is less studied and is of interest as a complexing agent [1,2] or as a precursor for biologically active compounds [3].

We have developed a method for preparation of substituted 2-oxonicotinic acids based on the reaction of 5-anilinomethylidene-2,2-dimethyl-1,3-dioxane-4,6-dione **4** with cyanoacetamides **5**. Compound **4** was prepared by reaction of Meldrum's acid **1** with triethyl orthoformate **3** and aniline **2**. The reaction of **4** with cyanoacetylhydrazide **5** afforded 1-amino-5-cyano-2-oxo-1,2-dihydrionicotinic acid **6**. The structure was confirmed by means of FTIR, NMR and X-ray data.



**Scheme 1.** Preparation of 1-amino-5-cyano-2-oxo-1,2-dihydrionicotinic acid **6**.



**Figure 1.** Molecular structure of compound 6 (X-ray data).

### References

- [1] Di Marco V.B.; Tappro A.; Dolmella A.; Bombi G.G. Complexation of 2-hydroxynicotinic and 3-hydroxypicolinic acids with zinc (II). Solution state study and crystal structure of trans-diaqua-bis-(3-hydroxypicolinato) zinc (II) // *Inorg. Chim. Acta* 2004. V. 357. P. 135–142.
- [2] Yoshito O.; Fumiaki H.; Yoshihiro T.; Takayasu K. Studies on the interaction of pyridone carboxylic acids with metals // *Chem. Pharm. Bull.* 1992. V. 40. P. S692–S696.
- [3] Fossa P.; Menozzi G.; Dorigo P.; Floreani M.; Mosti L. Synthesis and pharmacological characterization of functionalized 2-pyridones structurally related to the cardiotoxic agent milrinone // *Bioorg. Med. Chem.* 2003. V. 11. P. 4749–4759.

NEW APPROACH TO THE SYNTHESIS OF 2,3-DIARYL-1,3-BUTADIENES VIA CONSISTENT DOUBLE  
ARYLATION OF 3-SULFOLENE

*Rzhevskiy S. A.*<sup>1</sup>, *Bogachev V. N.*<sup>1</sup>, *Nechaev M. S.*<sup>1,2</sup>, *Shurupova O. V.*<sup>1</sup>,  
*Topchiy M. A.*<sup>1</sup>, *Asachenko A. F.*<sup>1</sup>

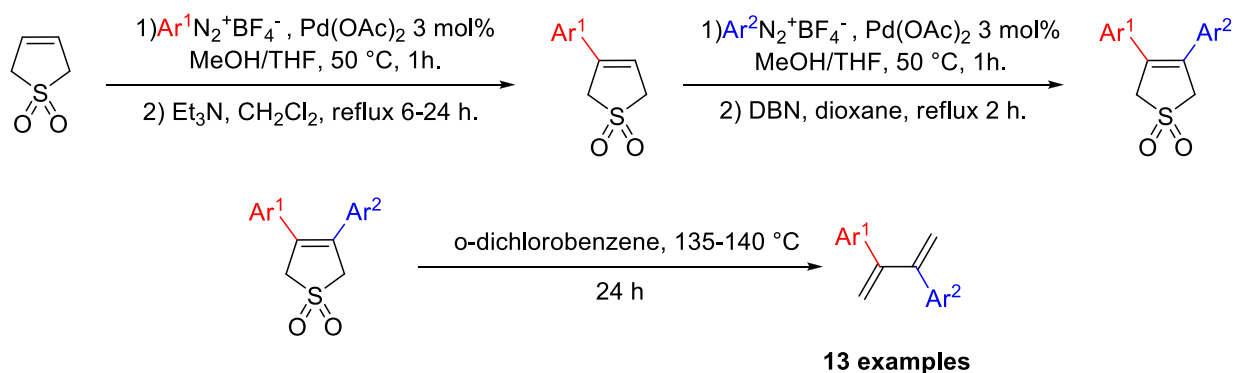
<sup>1</sup>A. V. Topchiev Institute of Petrochemical Synthesis, Russian Academy of Sciences, 119991 Moscow,  
Russian Federation.

<sup>2</sup>Department of Chemistry, M. V. Lomonosov Moscow State University, 119991 Moscow, Russian Federation  
[rs89@ips.ac.ru](mailto:rs89@ips.ac.ru)

Unsymmetrical 2,3-diaryl-1,3-butadienes are valuable intermediates in synthesis pyridines [1], pyrroles [2] and substituted indenenes [3]. They can be successfully used in polymerization process to obtain high-performance functional materials for organic electronic devices [4, 5].

Previously, we demonstrated an efficient and practical method for a scalable synthesis of 3-arylbutadiene sulfones using the ligand-free Heck–Matsuda reaction of sulfolene with aryldiazonium fluoroborates followed by triethylamine-promoted double bond shift [6].

An effective method of arylation of aryl-substituted butadiene sulfones to obtain 3,4-diarylsulfolenes has been developed. This method can be used to obtain non-symmetric derivatives containing acceptor, donor, and sterically hindered aryl substituents. It was shown that 3,4-diarylsulfolenes can be desulfurized with good yields. Thus, we have developed a convenient, scalable approach to the synthesis of 2,3-diarylbutadienes (Fig. 1).



**Figure 1.** Synthetic route to 2,3-diarylbutadienes.

#### References

- [1] Ohashi, M., et al., Nickel-Catalyzed Dehydrogenative [4 + 2] Cycloaddition of 1,3-Dienes with Nitriles. *Journal of the American Chemical Society*, 2011 133(45): p.18018-18021.
- [2] Yasukawa, N., et al., Copper-catalyzed pyrrole synthesis from 3,6-dihydro-1,2-oxazines. *Green Chemistry*, 2018 20(19): p. 4409-4413.
- [3] Eom, D., et al., Synthesis of Indenes via Brønsted Acid Catalyzed Cyclization of Diaryl- and Alkyl Aryl-1,3-dienes. *Organic Letters*, 2012 14(21): p. 5392-5395.
- [4] Yu, Y. and J. He, Anionic Polymerizations of Bis(terphenyl) Substituted Butadienes for Precursors of Head-to-Head Substituted Polyacetylenes. *Macromolecular Chemistry and Physics*, 2017 218(12): p. 1700080
- [5] Yu, Y., C. Qu, and J. He, Synthesis of asymmetrically substituted head-to-head polyacetylenes from 2,3-disubstituted-1,3-butadienes. *Journal of Polymer Science Part A: Polymer Chemistry*, 2019 57(3): p. 395-402.
- [6] Sergey A. Rzhevskiy, Vasilii N. Bogachev, Lidiya I. Minaeva, Grigorii K. Sterligov, Mikhail S. Nechaev, Maxim A. Topchiy and Andrey F. Asachenko, Efficient synthesis of 3-arylbutadiene sulfones using the Heck–Matsuda reaction *Mendeleev Commun.*, 2021, accepted manuscript.

Acknowledgements. This work was supported by Russian Science Foundation (RSF) for financial support (project number 19-73-10185).

# SYNTHESIS AND ELECTROCHEMICAL STUDIES OF NEW IMIDAZOL-4-ONES

*Saakian A. S., Bai X., Finko A. V., Moiseeva A. A., Beloglazkina E. K.*

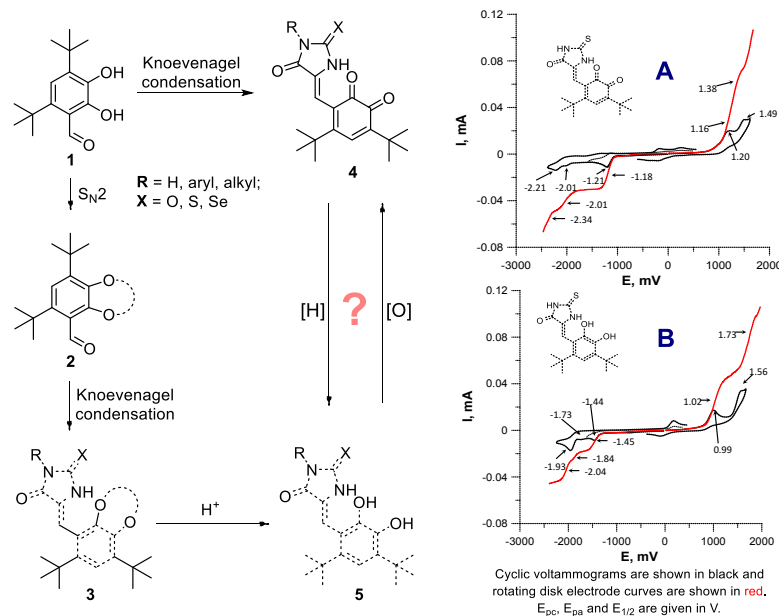
Moscow State University, Moscow, Russia

Student

[arevik-saakyan@mail.ru](mailto:arevik-saakyan@mail.ru)

Compounds containing fragments of quinone or hydroquinone/catechol are involved in the mechanisms of generation of reactive oxygen species (ROS). As a result, these molecules exhibit dual properties in biological systems [1]. It is known [2] that the redox potential between the quinone and hydroquinone/catechol pair has a direct impact on prooxidant and antioxidant effects. Thus, the manifestation of both cytotoxic and cytoprotective properties of these structures creates an increased interest in medicinal chemistry.

In our earlier papers [3, 4], we have shown cytotoxic properties of imidazolidine-2,4-dione derivatives and their ability to generate ROS. The work [5] reports on the antioxidant properties of thioesters of 3,5-di-tert-butylpyrocatechol. The imidazolidine fragment is a useful scaffold for the design of structures with variable substituents. Therefore, using this core structure we have synthesized derivatives of 3,5-di-tert-butylpyrocatechol and studied their electrochemical properties.



**Figure 1.** General synthesis and the electrochemical analysis of **A** and **B**

Aldehyde **1** was used as the starting compound. 2-Thioxoimidazolidin-4-one **4** was synthesized by Knoevenagel condensation. However, it was not possible to directly obtain the catechol derivative **5**. The use of protecting groups has led to the desired compound **5**. Cyclic voltammetry (CV) and rotating disc electrode method (RDE) have showed some electrochemical properties of 2-thioxoimidazolidine-4-ones **A** and **B**.

## References

- [1] Bolton J.L., Dunlap T. *Chem. Res. Toxicol.* **2017**, 30(1), 13–37.
- [2] Satoh T., Stalder R., McKercher S.R., Williamson R.E., Roth G.P., Lipton S.A. *ASN neuro*, **2015**, 7(4), 1759091415593294.
- [3] Novotortsev V.K., Kukushkin M.E., Tafeenko V.A., Skvortsov D.A., Kalinina M.A., Timoshenko R.V., Chmelyuk N.S., Vasilyeva L.A., Tarasevich B.N., Gorelkin P.V., Erofeev A.S., Majouga A.G., Zyk N.V., Beloglazkina E.K. *Int. J. Mol. Sci.* **2021**, 22(5), 2613.
- [4] Krasnovskaya O.O., Guk D.A., Naumov A.E., Nikitina V.N., Semkina A.S., Vlasova K.Y., Pokrovsky V., Ryabaya O.O., Karshieva S.S., Skvortsov D.A., Zhirkina I.V., Shafikov R.R., Gorelkin P.V., Vaneev A.N., Erofeev A.S., Mazur D.M., Tafeenko V.A., Pergushov V.I., Melnikov M.Y., Soldatov M.A., Shapovalov V.V., Soldatov A.V., Akasov R.A., Gerasimov V.M., Sakharov D.A., Moiseeva A.A., Zyk N.V., Beloglazkina E.K., Majouga A.G. *J. Med. Chem.* **2020**, 63(21), 13031–13063.
- [5] Smolyaninov I.V., Pitikova O.V., Korchagina E.O., Poddel'sky A.I., Fukin G.K., Luzhnova S.A., Tichkomirov A.M., Ponomareva E.N., Berberova N.T. *Bioorganic Chemistry*, **2019**, 89, 103003.

Acknowledgements. This work was supported by the Russian Foundation for Basic Research (project No 19-29-08007).

## CABOZANTINIB-BASED PROTACS SYNTHESIS

*Sachkova A.A.*<sup>1</sup>, *Shchegravina E.S.*<sup>1</sup>, *Fedorov A.Yu.*<sup>1</sup>, *Andreeva D.V.*<sup>2</sup>, *Tikhomirov A.S.*<sup>2</sup>, *Shchekotikhin A.E.*<sup>2</sup>

<sup>1</sup>Lobachevsky State University, Nizhny Novgorod, Russia

<sup>2</sup>Gause Institute of New Antibiotics, Moscow, Russia

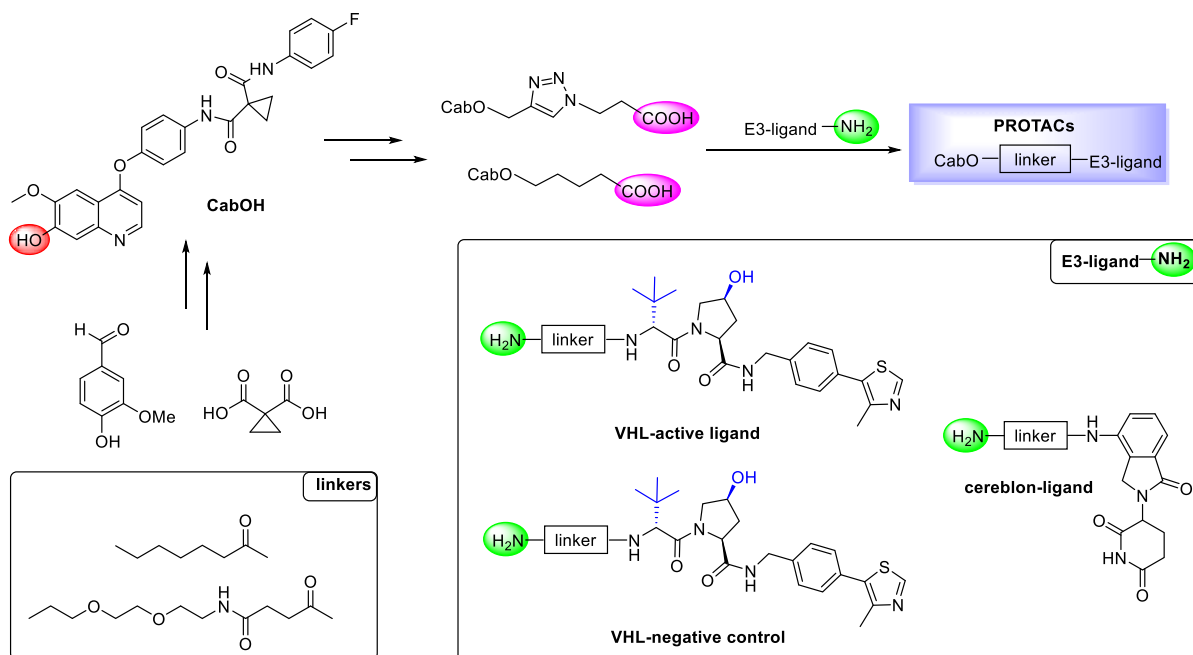
PhD student

[nastia.sachkova@yandex.ru](mailto:nastia.sachkova@yandex.ru)

PROTACs (PROteolysis TARgeting Chimeras) are bifunctional molecules containing two ligands. One ligand binds to the target pathogenic protein, while the other part of PROTAC interacts with ubiquitin E3 ligase, which promotes the binding of the target protein to ubiquitin and its subsequent proteasomal degradation.

We synthesized PROTACs, based on the multikinase inhibitor cabozantinib as a ligands for the target pathogenic proteins (Fig.1). The hydroxy- derivative of cabozantinib (CabOH), obtained by previously published method [1], was successfully modified by a carboxyl group insertion in two steps. Presence of carboxyl group is needed to conjugate cabozantinib derivative with the second part of PROTAC in amine form. Inhibitors of von Hippel-Lindau protein (VHL) [2-3] and cereblon (CRBN) [4] were used as the second component of PROTACs, recruiting E3- ubiquitin ligases.

The next step would be to investigate biological activity of obtained compounds.



**Figure 1.** PROTACs synthesis.

### References

- [1] US7579473B2.
- [2] WO2017184995
- [3] Steinebach, C. et al. *Chem. Commun.*, **2019**, 55, 1821-1824.
- [4] Zhang, F. et al. *Bioorg Med Chem.*, **2020**, 28, 115228.

Acknowledgements. This work was supported by the Russian Science Foundation (project No 19-13-00158).

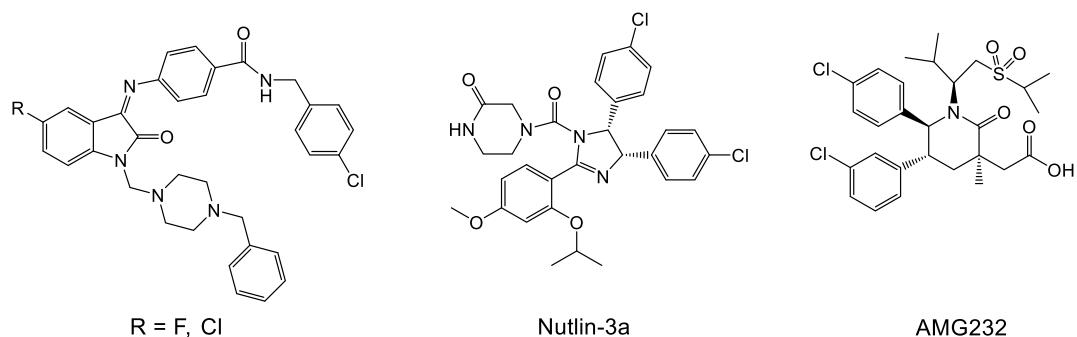
# STUDY ON BIOLOGICAL ACTIVITY OF MDM2 INHIBITORS IN THE CONTEXT OF TUMOR CHEMORESISTANCE DEVELOPMENT

*Sagaidak A.V., Romanova A.A.*

Saint-Petersburg State Institute of Technology, Saint-Petersburg, Russia  
PhD student  
aleksandrasagaidak@yandex.ru

It is known that pharmacological suppression of the p53-MDM2 protein-protein interaction in tumor cells leads to the stabilization of p53 and stimulation of its antitumor activity by activating transcriptional targets [1]. However, despite the activation of p53-dependent cell death in most tumor cells, surviving cells can become chemoresistant. Drug resistance is a major obstacle in the treatment of tumors, and ABC transporters play an important role in its development, pumping out the active substance from the cell.

In this work, we studied the biological activity of MDM2 inhibitors of several classes: *cis*-imidazoline Nutlin-3a, piperidinone AMG232 and indolinones **1** and **2** (Figure 1) [2].



**Figure 1.** Structures of p53-MDM2 protein-protein interaction inhibitors

The effect of the studied substances on processes associated with the development of chemoresistance, namely, on the activity of ABC transporters and on the expression level of the corresponding genes, was studied. High-content screening and real-time RT-PCR were used.

It was found that although the compounds do not significantly affect the transport activity in the cells, they are capable of activating expression of chemoresistance genes to varying degrees. According to the data of real-time RT-PCR, the degree of expression activation was different for different chemical classes of MDM2 inhibitors. Thus, despite the fact that targeted agents seem to be safer compared with cytostatics, possible risks of activating processes that determine the development of chemoresistant tumors should be considered during their design.

## References

- [1] Zheltuhin A., Chumakov P. *Advances biol. chemistry* **2010** 50 447-516
- [2] Fedorova O., Daks A. et al. *Cell Cycle* **2018** 17 1917-1930

Acknowledgements. This work was supported by the Russian Science Foundation (project No 19-73-10150).



# DESIGN, PHOTOCHEMICAL SYNTHESIS AND MOLECULAR DYNAMIC CALCULATIONS OF BENZO[D]THIAZOLO[3,2-A]QUINOLIN-10-IUM DERIVATIVES AS DNA INTERCALATORS

*Saifutiarova A.E.<sup>1</sup>, Fedorov Y.V.<sup>1</sup>, Tsvetkov V.B.<sup>2</sup>, Gulakova E.N.<sup>1</sup>, Chmelyuk N.S.<sup>3</sup>,  
Abakumov M.A.<sup>3</sup>, Fedorova O.A.<sup>1</sup>*

<sup>1</sup>A. N. Nesmeyanov Institute of Organoelement Compounds of Russian Academy of Sciences, Russia,

<sup>2</sup>D. Mendeleev University of Chemical Technology of Russia, Russia

<sup>3</sup>WCRC "Digital biodesign and personalized healthcare", Sechenov First Moscow State Medical University, Russia.

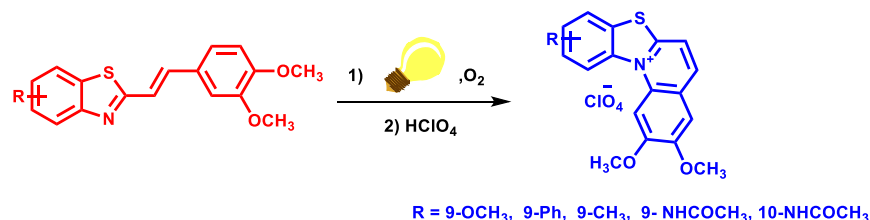
<sup>4</sup>Laboratory "Biomedical Nanomaterials", National University of Science and Technology "MISIS", Leninskiy Prospect, 4, 119049 Moscow, Russia

PhD Student

[bayakova.alina@gmail.com](mailto:bayakova.alina@gmail.com)

Benzothiazole derivatives have the status of universal heterocyclic scaffold owing to its pharmacological applications in targeting several biological enzymes, receptors, dyes, imaging and in cancer biology.

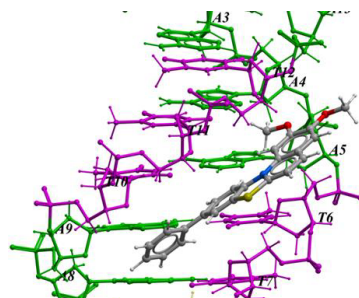
Based on the earlier findings, and in continuation of our previous research in design and synthesis of new intercalating agents [1-3], we report the design and synthesis a new series of benzo[d]thiazolo[3,2-a]quinolin-10-ium derivatives (Fig. 1).



**Figure 1.** The reaction for obtaining a series of benzo[d]thiazolo[3,2-a]quinolin-10-ium derivatives

The proposed structures are promising DNA intercalators. They have significant structural features, namely a flat polyaromatic system and cationic particles that enhance interaction with negatively charged sugar-phosphate DNA. The variability of substitutions in the benzothiazole fragment allowed us to study their binding to DNA, anticancer activity against four groups of cell lines using MTT analysis and to carry out molecular dynamics calculations.

Conducted docking and molecular dynamic calculations supported the results of the possible binding interactions of the target compounds with DNA through the intercalation and demonstrated the effect of substituent in the benzothiazole moiety on the structure of the formed DNA-ligand complex (Fig. 2).



**Figure 2.** Conformations of compounds 2 with the lowest binding energy obtained in the docking procedure

All prepared ligands showed good DNA binding affinities and different anticancer activity against four cell lines. So, further structural optimization of the most active candidates which may serve as useful lead compounds in search for powerful and selective anticancer agents could be considered as promising.

## References

- [1] Berdnikova D. V., Aliyev T.M., Paululat T., Fedorov Y. V., Fedorova O.A., Ihmels H. *Chem. Commun.* **2015**, 51, 4906–4909
- [2] Aliyev T.M., Berdnikova D. V., Fedorova O.A., Gulakova E.N., Stremmel C., Ihmels H. *J. Org. Chem.* **2016**, 81, 9075–9085
- [3] Gulakova E.N., Berdnikova D. V., Aliyev T.M., Fedorov Y. V., Godovikov I.A., Fedorova O.A. *J. Org. Chem.* **2014**, 79, 5533–5537

Acknowledgements. This work was supported by Russian Science Foundation (project No 19-43-04127)

# ELECTROCYCLIC REACTIONS IN SEVEN-MEMBERED SYSTEMS: TOWARDS INNOVATIVE FUNCTIONAL MATERIALS

Salikov R.F.<sup>1</sup>, Tomilov Y.V.<sup>1</sup>

<sup>1</sup>N. D. Zelinsky Institute of Organic Chemistry, Russian Academy of Sciences, Moscow, Russia  
Young scientist  
[rinat\\_salikov@ioc.ac.ru](mailto:rinat_salikov@ioc.ac.ru)

Electrocyclic reactions have been a potent approach to develop new carbo- and heterocyclic systems. The cascades employing electrocyclic transformations open the way to the synthesis of hepta(methoxycarbonyl)cycloheptatrienyl potassium and penta(methoxycarbonyl)cyclopentadienyl potassium or sodium that proceeds via a common vinylpyridinium intermediate [1-2]. Furthermore, the interconversions between the five- and seven-membered systems have been studied (Fig. 1).

In both the cases, the obtained products were found to be quite universal synthons for the synthesis of promising functional materials. In particular, penta(methoxycarbonyl)cyclopentadienyl anion was used in the synthesis of novel dyes containing the proaromatic hydrazinylidencyclopentadiene acceptor fragment [3]. Though three methods were used to obtain the desired series of compounds, only two of them were tested in bulk heterojunction solar cells [4]. The maximum efficiency achieved so far for the devices under study comprised 2%.

Moreover, electrocyclic transformations of hepta(methoxycarbonyl)cycloheptatrienyl potassium in a reaction with amines gave new fluorescent electron-deficient 5-hydroxyisoquinolones [5]. A large Stokes shift was registered for the synthesized class of fluorescent dyes along with a noticeable quantum yield. Additionally, 5-hydroxyisoquinolones demonstrated superphotoacidic properties, i.e. an increase in acidity in excited state, which holds promises for various applications such as enhancing photo-induced cation polymerization.

Other cascade reactions of vinylpyridinium with CH-acids gave cycloheptadienes, bicycloheptenes or pyridinium cyclopentadienolate which in turn gave a series of donor-acceptor chromophores [6].

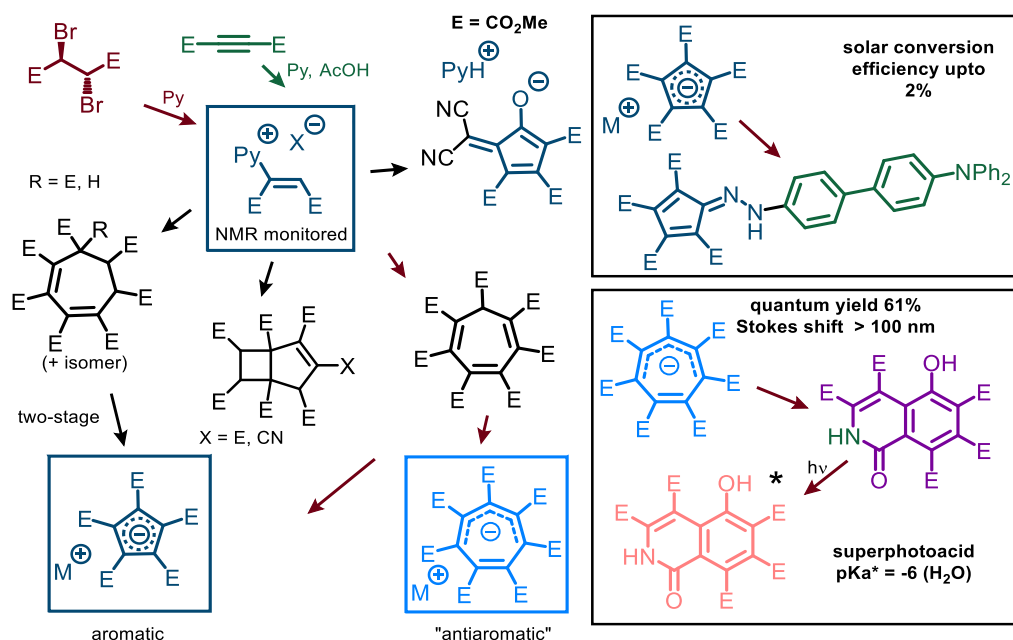


Figure 1. Electrocyclic reactions in seven-membered systems.

## References

- [1] Belyy A.Y., Platonov D.N., Salikov R.F., Levina A.A., Tomilov Y.V. *Synlett*. **2018**, 1157.
- [2] Salikov R.F., Trainov K.P., Platonov D.N., Belyy A.Y., Tomilov Y.V. *Eur. J. Org. Chem.* **2018**, 5065.
- [3] Salikov R.F. *et al. Dyes Pigm.* **2019**, 500.
- [4] Trainov K.P. *et al. Mend. Commun.* **2019**, 304.
- [5] Belyy A.Y. *et al. Dyes Pigm.* **2021**, 109107.
- [6] Trainov K.P. *et al. Dyes Pigm.* **2021**, 109132.

# NOVEL ANTITUMOR AGENTS BASED ON 3,7-DIAZABICYCLONONANE DERIVATIVES

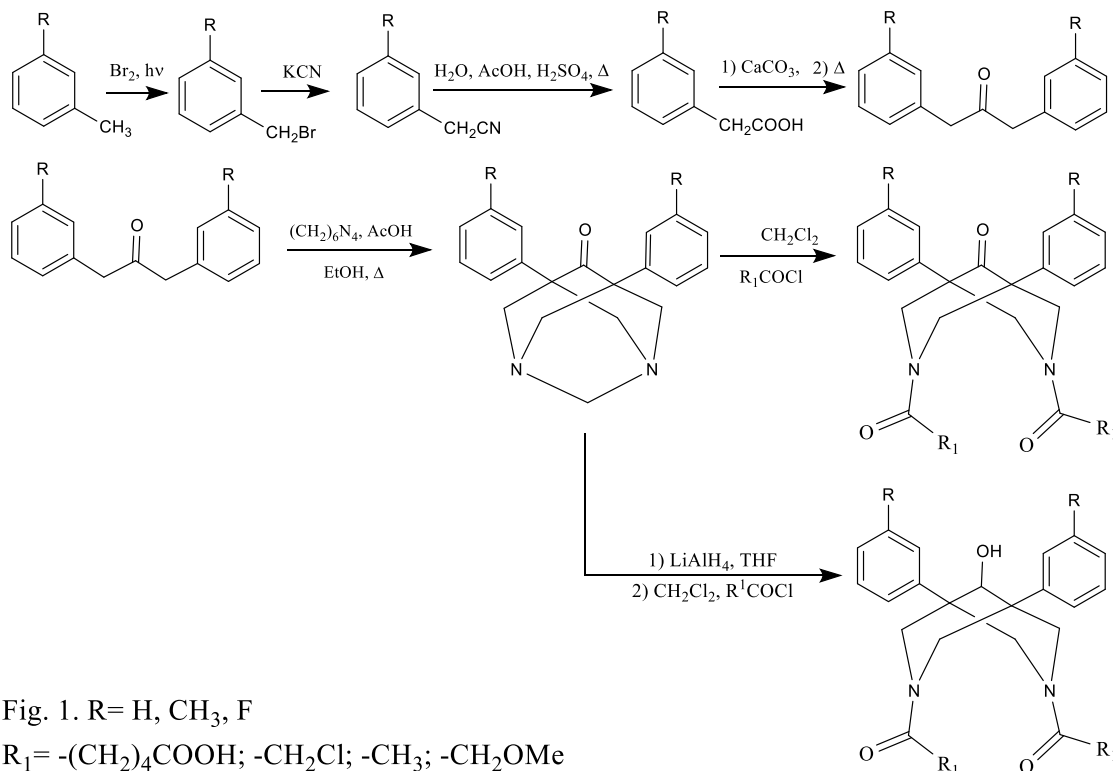
*Salykina M.A., Sosonyuk S.E.*

Moscow State University, Moscow, Russia

Student

[maria.salykina@chemistry.msu.ru](mailto:maria.salykina@chemistry.msu.ru)

We synthesized derivatives of 3,7-diazaadamantane from m-xylene and m-fluorotoluene by radical bromination followed by nucleophilic substitution of bromine to cyanide, acidic hydrolysis, acid ketonization and Mannich reaction [1-2]. We also carried out reduction of ketones with  $\text{LiAlH}_4$ . Target molecules were obtained by amination degradation with an acyl chloride (Fig. 1). The cytotoxicity of obtained compounds was investigated in different cancer cell lines. The inhibition activity of all compounds was also tested in vitro against quinone oxidoreductase 2.



**Figure 1.**

## References

- [1] Sosonyuk S.E., et al. *Org. Biomol. Chem.*, **2019**, *56*, 915–922  
 [2] Levinger S., et al. *Org. Chem.*, **2008**, *73*, 7793

Acknowledgements. This work was supported by the Russian Foundation for Basic Research (Project No 20-03-00915).

N-HEXADECANE HYDROISOMERIZATION OVER NiMoS/Al<sub>2</sub>O<sub>3</sub>-Beta IN THE PRESENCE OF NITROGEN-CONTAINING COMPOUNDS IN THE FEEDSTOCK

*Savinov A.A.<sup>1</sup>, Tochilin N.V.<sup>1</sup>, Vinogradov N.A.<sup>1</sup>, Pimerzin A.A.<sup>1</sup>*

<sup>1</sup>Samara State Technical University, Samara, Russia  
Savinoov13@gmail.com

Hydroisomerization of n-alkanes is widely used in the oil refining and petrochemical industries, as it improves the octane number of gasoline and low-temperature properties of diesel fuels and lubricating oils.

Bifunctional catalysts are used in hydroisomerization process due to they have both hydrogenation/dehydrogenation sites and acidic sites. The hydrogenation/dehydrogenation sites are usually presented by noble metals of platinum group. Their main disadvantages are high sensitivity to catalytic poisons (heteroatomic sulfur and nitrogen-containing compounds) and high cost. Therefore, transition metal sulfides are becoming more and more in demand.

The presence of acid sites is ensured by modifying the commonly used alumina with zeolites and aluminosilicates. At the same time, the important function of the support to provide not only the necessary acidity for the hydroisomerization reaction, but also the access of molecules to the active sites.

This work presents the results of the study of NiMo catalyst on supported the modified alumina. The carrier was obtained by co-extrusion of boehmite and the acidic additive (zeolite β). The catalysts were prepared by incipient wetness impregnation with aqueous solutions of precursors: phosphomolybdenum heteropoly acid and nickel carbonate. Citric acid was used as chelating agent. The molar ratio Ni / Mo was 1/2.

The isomerization reaction was carried out in a laboratory flow-through unit under the following conditions: 260°C; pressure 1.5 MPa, hydrogen flow rate 1 l/h, Liquid Hourly Space Velocity 1-2 h<sup>-1</sup>. N-hexadecane was used as a model linear alkane. Quinoline was used as a nitrogen source. The nitrogen content in the feed varied from 10 to 50 ppm. The reaction products were studied by GC-method. The obtained results are summarized in the table 1.

Table 1  
Results of catalytic tests of NiMoS/Al<sub>2</sub>O<sub>3</sub>-Beta catalyst in n-hexadecane hydroisomerization

Property	Nitrogen content in the feed, ppm				
	0	10	20	30	50
$x_{iso}$ %	30,2	30,9	27,4	22,7	12,2
$k_{iso} \times 10^5$ , mol g <sup>-1</sup> h <sup>-1</sup>	10,2	9,1	8,4	6,8	2,1
$x_{cr}$ %	20,9	2,3	1,6	0,4	0
$k_{cr} \times 10^5$ , mol g <sup>-1</sup> h <sup>-1</sup>	6,1	0,5	0,2	0,1	0
$Se_{iso}$ , %	59,2	93,1	94,5	98,3	100

The obtained results show that nitrogen-containing compounds are poison the acid sites of bifunctional catalyst. At low concentrations (10-20 ppm) the isomerization activity of the catalyst remains almost unchanged, while the selectivity increases significantly from 60 to 95%. Such result may be due to the poisoning of strong acid sites on which cracking reactions take place. A further increase in the concentration of nitrogen-containing compounds leads to irreversible poisoning of all acid sites and complete deactivation.

This work was supported by the Government of the Russian Federation (resolution no. 220 of April 9, 2010; grant no. 14.Z50.31.0038 of February 20, 2017).

# ELECTROCHEMICAL OXIDATIVE C-O AND N-O COUPLING OF VINYL AZIDES WITH N-HYDROXYPHTHALIMIDE

*Segida O.O.*<sup>1</sup>, *Fedorova U.V.*<sup>2</sup>, *Antonova L.S.*<sup>1,2</sup>, *Paveliev S.A.*<sup>1</sup>, *Terent'ev A.O.*<sup>1,2</sup>

<sup>1</sup> N.D. Zelinsky Institute of Organic Chemistry of the Russian Academy of Sciences, Moscow, Russia

<sup>2</sup> D. Mendeleev University of Chemical Technology of Russia, Moscow, Russia

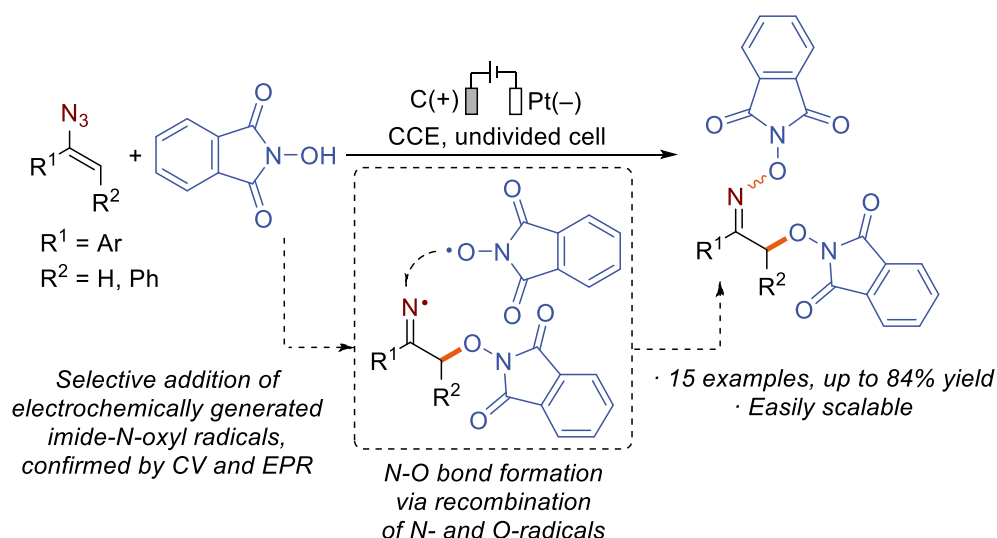
PhD Student

[segoleg@gmail.com](mailto:segoleg@gmail.com)

Currently, preparative organic electrochemistry is one of the most rapidly developing areas of modern organic chemistry. [1] Electrochemical reactions involving stabilized O-centered N-oxyl radicals represent a challenging area of electrosynthesis. [2] Generation of imide-N-oxyl radicals as a result of anodic oxidation of N-hydroxyimides and their selective reactions with substrates remains problematic due to the low stability of such radicals under electrochemical conditions and their tendency to self-decomposition. [3]

Reactions involving vinyl azides, in which various radicals are attached to the terminal carbon atom of the multiple C=C bond, followed by the release of the N<sub>2</sub> molecule, have been actively studied recently. [4] As a rule, the outcome of such processes is formation of iminyl radical and its subsequent transformations resulting enamines or ketones, as well as intramolecular cyclization or homocoupling. To the best of our knowledge there are no examples of the selective intermolecular addition reactions involving iminyl radicals.

In the present work, it was found that imide-N-oxyl radicals, anodically generated from N-hydroxyphthalimide selectively react with vinyl azides resulting in the formation of O-substituted oximes with N-O-N fragment. The main feature of the work is the formation of a new N-O bond through the recombination of N-centered iminyl radicals and O-centered N-oxyl radicals (Figure 1).



**Figure 1.** Electrochemical coupling of vinyl azides with N-hydroxyphthalimide

## References

- [1] Frontana-Urbe B. A. et al. *Green Chem.* **2010**, *12*(12), 2099-2119
- [2] Nutting J. E., Rafiee M., Stahl S. S. *Chem. Rev.* **2018**, *118*(9), 4834-4885
- [3] Ueda C. et al. *Chem. Pharm. Bull.* **1987**, *35*(4), 1372-1377
- [4] Hayashi H., Kaga A., Chiba S. *J. Org. Chem.* **2017**, *82*(23), 11981-11989

Acknowledgements. This work was supported by Russian Foundation for Basic Research (project No 19-29-08027).

LEWIS ACID-CATALYZED FORMAL (4+2)- AND (2+2+2)-CYCLOADDITION BETWEEN 1-AZADIENES AND STYRYLMALONATES AS ANALOGUES OF DONOR-ACCEPTOR CYCLOPROPANES

*Sergeev P.G., Novikov R.A., Tomilov Yu.V.*

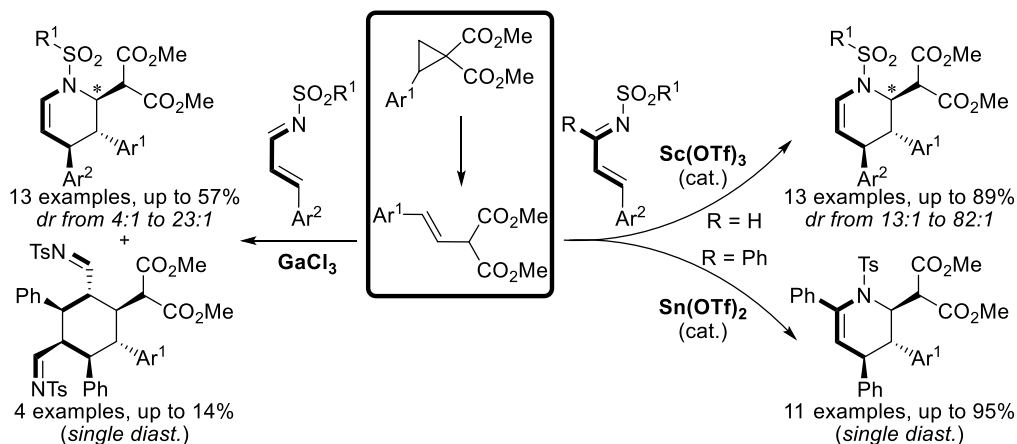
N.D. Zelinsky Institute of Organic Chemistry, Russian Academy of Sciences, Moscow, Russia  
PhD student

[sergeevpg@gmail.com](mailto:sergeevpg@gmail.com)

Donor-acceptor cyclopropanes (DACs) proved themselves as important building blocks in the modern organic synthesis, primarily as sources of 1,3-zwitterions in the presence of various Lewis acids or as 1,2-zwitterionic intermediates in the presence of gallium halides. Among the chemical transformations of DACs, the reactions of isomeric styrylmalonates and alkylidenemalonates with dienes and their heteroanalogues in the presence of Lewis acids, in particular GaCl<sub>3</sub>, are of special interest, first of all, in the formation of cyclic systems.

In fact, cyclization reactions of DACs with azadienes in the presence of Lewis acids allows the creation of functionalized five- and six-membered carbo- and heterocyclic compounds. However, it should be noted that only a few reactions of ACDCs with N-heterodiene derivatives such as  $\alpha,\beta$ -unsaturated imines in the presence of Lewis acids have been described in the literature [1–3]. Among them, reactions of only one type occurred with full involvement of the azadiene system to give (4+2)-cycloaddition products (tetrahydropyridines) via styrylmalonates generated in situ from ACDCs.

In current work, the reactions of donor-acceptor cyclopropanes and isomeric  $\beta$ -styrylmalonates with conformationally non-rigid  $\alpha,\beta$ -unsaturated imines in the presence of Lewis acids were studied [4]. The effect of the structural features of starting compounds on the process course was determined. The main attention was focused to discover the reaction conditions for the formal (4+2)-cycloaddition pathway with the possibility of variation of the  $\alpha$ -substituent in azadiene instead of known (3+2)-cycloaddition synthetic methodology. Based on the results obtained, a method for the diastereoselective synthesis of substituted *trans,trans*-tetrahydropyridines was developed. Three substrate-sensitive diverse Lewis acid catalytic systems have been employed based on Sc(OTf)<sub>3</sub>, Sn(OTf)<sub>2</sub>, and GaCl<sub>3</sub>. The use of GaCl<sub>3</sub> as a Lewis acid allows to obtain a minor product of the formal (2+2+2)-cycloaddition, which represents a fully 1,2,3,4,5,6-hexasubstituted cyclohexane derivative produced with diastereoselectivity >30:1. Appropriate mechanistic and stereochemical models have been suggested.



**Figure 1.** Reactions of styrylmalonates with 1-azadienes.

#### References

- [1] K. Verma, P. Banerjee. *Adv. Synth. Catal.* **2017**, 359, 3848–3854
- [2] K. Verma, P. Banerjee. *Adv. Synth. Catal.* **2018**, 360, 3687–3692
- [3] K. Verma, I.M. Taiyya, P. Banerjee. *Org. Biomol. Chem.* **2019**, 17, 8149–8152
- [4] P.G. Sergeev, R.A. Novikov, Yu.V. Tomilov. *Adv. Synth. Catal.* **2021**, in press (10.1002/adsc.202100453)

Acknowledgements. This work was supported by the Russian Science Foundation (RSF grant no. 19-73-10210).

# BIOMINERALISATION OF CALCIUM PHOSPHATE COATINGS IN ORGANIC MATRIX IN THE PRESENCE OF ALPHA-AMINO ACIDS

*Serykh T.A.<sup>1</sup>, Badretdinova V.T.<sup>1</sup>, S.A.Ulasevich<sup>1</sup>*

<sup>1</sup>ITMO University, Saint Petersburg, Russia  
Student

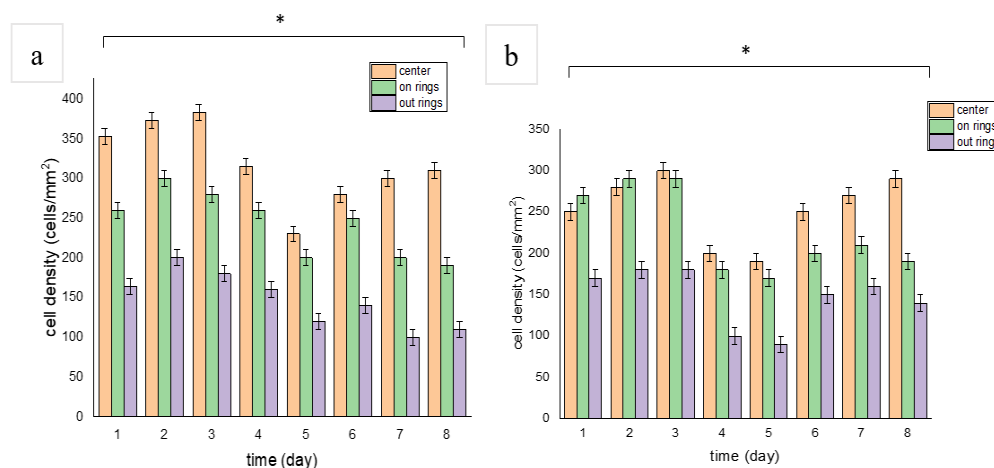
[Serykh@infochemistry.ru](mailto:Serykh@infochemistry.ru)

Currently, considerable attention is being paid to the study of the deposition of calcium phosphate materials. Until now the mechanism of precipitation of calcium phosphates in living organisms is of interest. In this regard, the study of the origin and growth rate of calcium phosphates is of particular interest for many industries, such as medicine, biomedicine, biochemistry, analytical and physical chemistry, etc. Moreover, the study of the deposition of calcium phosphate minerals is necessary to uncover the normal and pathological mechanisms of mineralization [1,2]. Thus, the study of the biomineralization process is an urgent task.

The aim of our research is to study the processes of crystallization of calcium phosphate in a biopolymer matrix in the presence of optically active  $\alpha$ -amino acids and other substances.

We have formed structures with a gradient distribution of the phase composition of calcium phosphates and the introduced substances. Our approach is to develop a model system to study the hydroxyapatite formation in biopolymer matrix in the presence of alpha-amino acids and metabolically active substances. We chose alpha-amino acids and metabolically active substances because they play an important role in the human body and in the formation of bones. L-glutamic acid and L-ascorbic acid were used in various concentrations from 10 nmol L<sup>-1</sup> to 10 mmol L<sup>-1</sup>. A model system without the addition of acids was used as a control.

A cell line C2C12 was seeded on the model system and the cell density was 5 · 10<sup>5</sup> cells / cm<sup>3</sup>. In addition, the proliferation and differentiation of mouse myoblast cell culture (C2C12) on periodically formed patterns in the presence of  $\alpha$ -amino acids was investigated. The experiment was carried out for 8 days. Figure 1 shows proliferation of C2C12 on the surface of calcium phosphates patterns.



**Figure 1.** Proliferation of C2C12 on the surface of calcium phosphates patterns: a) sample with L-glutamic acid addition; b) control sample without additives

As a result of the work, it was found that the addition of  $\alpha$ -amino acids causes cell growth. With the addition of L-glutamic acid, cells grow faster than with L-ascorbic acid and with control. Moreover, there is an increase in the cell area with the addition of amino acids. Thus, the C2C12 cell line is biocompatible with the model derived system.

## References

- [1] Elsharkawy S., Al-Jawad M., Pantano M. F., Tejada-Montes E., Mehta K., Jamal H., Agarwal S., Shuturminska K., Rice A., Tarakina N. V., et al., *Nat. Commun.* **2018**, 9.
- [2] Shimizu ] Y., Matsui J., Unoura K., Nabika H., *J. Phys. Chem. B* **2017**, 121, 2495.

Acknowledgements. This work was supported by the Russian Science Foundation (project No 19-79-10244).

SYNTHESIS AND BIOLOGICAL ACTIVITY OF N-HET(ARYL)AMIDES  
OF 4-(HET(ARYL)-2-(2-BENZO[D]THIAZOL-2-YL)HYDRAZONE-4-OXOBUTANOIC ACIDS

*Shaymardanov A.R.*<sup>1</sup>, *Sobin F.V.*<sup>1</sup>, *Pulina N.A.*<sup>1</sup>, *Zykova S.S.*<sup>1</sup>

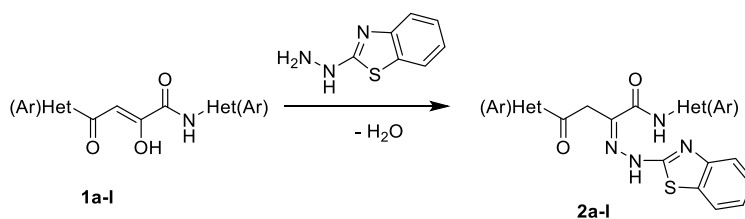
<sup>1</sup>Perm State Pharmaceutical Academy, Perm, Russia

Student

[fff-2005@mail.ru](mailto:fff-2005@mail.ru)

We have previously shown that the introduction of benzo[d]thiazole pharmacophoric fragment into the structure of 4-R-2-hydroxy-4-oxo-2-butenoic acid derivatives allows to increase significantly the pharmacological effect of initial compounds or to reveal new types of biological activity [1-3]. It was of interest to propose an alternative route to introduce the N-het(aryl)amide 4-R-2-hydroxy-4-oxo-2-butenoic acids benzo[d]thiazole fragment into the initial matrix. 2-Hydrazinobenzo[d]thiazole was chosen as a nucleophilic reagent, which has been successfully used for the synthesis of new biologically active compounds with a wide spectrum of biological activity [4].

Direct interaction of N-het(aryl)amides of 4-R-2-hydroxy-4-oxo-2-butenoic acids (1a-l) with 2-hydrazinobenzo[d]thiazole in an equimolar reagent ratio in anhydrous chloroform medium at room temperature or heating resulted in new N-het(aryl)amides of 4-(het(aryl)-2-(2-benzo[d]thiazol-2-yl)hydrazone-4-oxobutanoic acids (2a-l):



**Figure 1.** Synthesis of N-het(aryl)amides of 4-(het(aryl)-2-(2-benzo[d]thiazol-2-yl)hydrazone-4-oxobutanoic acids

The structure of the compounds has been proved by a set of instrumental methods of analysis and is consistent with the data for related structures. Preliminary screening of biological activity allowed detecting compounds with antioxidant activity. Some regularities in the relationship between the structure of compounds and their pharmacological effects have been established.

#### References

- [1] Pulina N.A., Lipatnikov K.V, Sobin F.V., Makhmudov R.R., Dubrovina S.S. *J. Gen. Chem.* **2018**, *88*(8), 1618–1622
- [2] Pulina N.A., Sobin F.V., Yushkova T.A, Novikova V.V. *Russian Chemical Bulletin* **2019**, *68*(3), 628-633
- [3] Sobin F.V., Pulina N.A, Lipatnikov K.V, Starkova A. V., Yushkova T. A., Naugol'nykh E. A. *Pharmaceutical Chemistry Journal* **2020**, *54*(10), 1003-1007
- [4] Khadija O. Badahdah, Hamida M. Abdel Hamid, Sawsan A. Nouredin. *J. Heterocyclic Chem.* **2014**, *52*(1), 67–74



# HIGHLY POTENT ALLOCOLCHICINE DERIVATIVES AND THEIR PHOSPHOLIPIDIC PRODRUGS FOR INCORPORATION IN ENZYMATICALLY-TRIGGERED LIPOSOMES

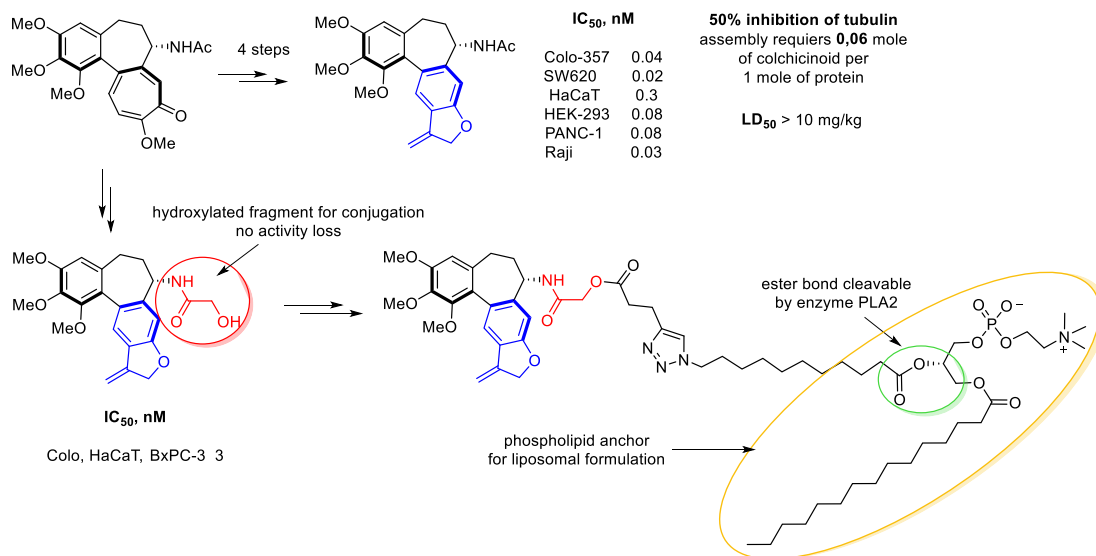
*Shchegravina E.S.*<sup>1</sup>, *Tretiakova D.S.*<sup>2</sup>, *Svirshchevskaya E.V.*<sup>2</sup>, *Boldyrev I.A.*<sup>2</sup>, *Fedorov A.Yu.*<sup>1</sup>

<sup>1</sup>UNN Lobachevsky State University, Nizhny Novgorod, Russia

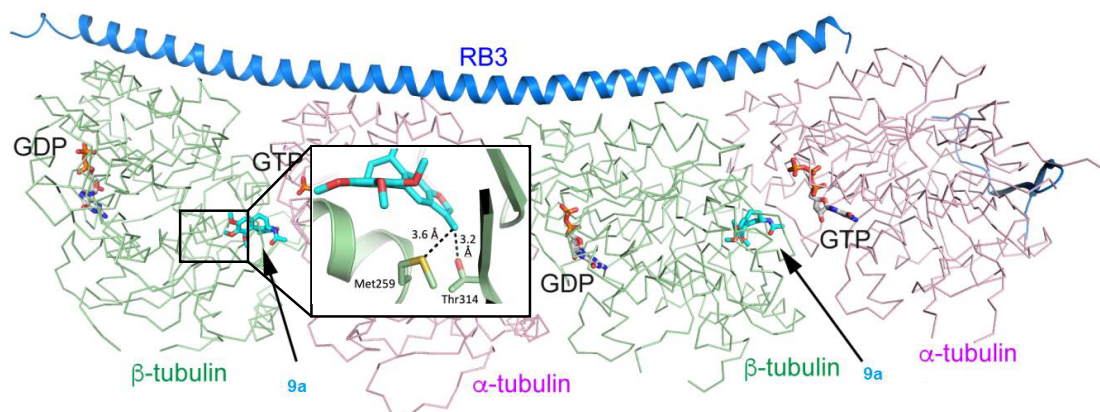
<sup>2</sup>Institute of biorganic chemistry RAS, Moscow, Russia

[sc.katarina@yandex.ru](mailto:sc.katarina@yandex.ru)

Naturally occurring alkaloid colchicine is considered as convenient platform for design new oncological drug candidates. Based on previous research new heterocyclic colchicines analog was developed. Due to its cytotoxic activity in sub-nanomolar range, high tubulin affinity and significant decreasing of acute toxicity in comparison with colchicine [1], we decided to develop its lipid prodrug for further incorporation in enzymatically-triggered liposomes [2].



**Figure 1.** Concept of heterocyclic colchicine analog and its lipid prodrug



**Figure 2.** The T2R:colchicinoid complex comprises two αβ-tubulin heterodimers [1]

## References

- [1] E.S. Shchegravina *et al.* *Eur. J. Med. Chem.*, **2020**, *207*, 112724  
 [2] E.S. Shchegravina *et al.* *Bioconjugate Chem.* **2019**, *30*, 1098-1113

Acknowledgements. This work was supported by the Russian Science Foundation (project No 19-13-00158)

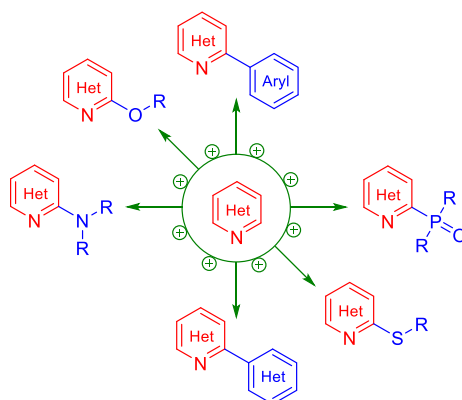
# USE OF ELECTROCHEMISTRY IN THE REACTION OF DIRECT C-H FUNCTIONALIZATION OF HETEROCYCLIC STRUCTURES

*Shchepochkin A.V.<sup>1</sup>, Chupakhin O.N.<sup>1</sup>*

<sup>1</sup>Institute of Organic Synthesis of the Russian Academy of Sciences, Ekaterinburg, Russia  
PhD  
avs@ios.uran.ru

Various heterocycles are widely used in organic materials, agrochemicals, and pharmaceuticals. Therefore, the production, transformation and study of the specific properties of heterocyclic structures is undoubtedly the most actively developed area of organic chemistry. Unfortunately, modification of the heterocycle structure requires the use of expensive reagents, harsh conditions, long reaction times, and the formation of a large amount of waste [1]. Consequently, new compatible and more sustainable synthetic approaches for the functionalization of heterocycles are in great demand.

Use of electrochemical methods appears to be a very attractive alternative. With the use of electron as the mass-free reagent, electrosynthesis is regarded to be environmentally friendly since the usage of stoichiometric amount of chemical reagents in conventional chemical transformations are taken over by catalytic employment or avoided completely, thereby eliminating the produce of waste. Besides development of the atom-economical version of the oxidative reactions, electrochemical methods provide an opportunity to get insight into the reaction mechanism [2-3].



**Figure 1.** Electrochemical C-H functionalization of heterocycles

The report will present the latest results in the field of electrochemical functionalization of heterocycles, obtained in our laboratory and including the issues of arylation, hetarylation, amination, phosphorylation and introduction of other heteroatomic fragments.

## References

- [1] Heterocyclic Chemistry; Joule, J. A., Mills, K., Eds.; Wiley-Blackwell: Hoboken, 2010
- [2] Chupakhin, O. N., Shchepochkin, A. V., Charushin, V. N. *Advances in Heterocyclic Chemistry* **2020**, 131, 1-47
- [3] Yan, M., Kawamata, Y., Baran, P. S. *Chem. Rev.* **2017**, 117, 13230-13319

Acknowledgements. This work was supported by Russian Foundation for Basic Research (project No 19-29-08037).

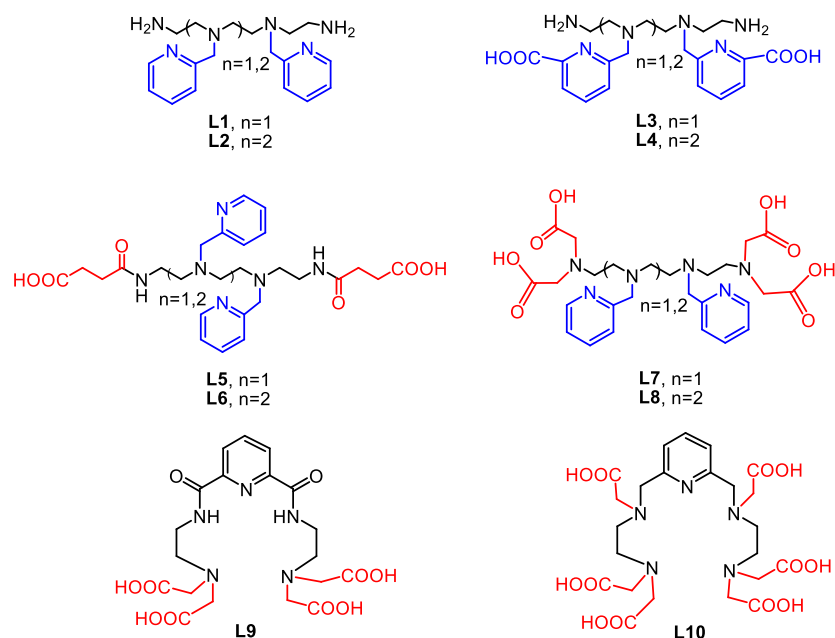
# SYNTHESIS OF ACYCLIC LIGANDS AS COMPONENTS OF RADIOPHARMACEUTICALS

*Shchukina A.A., Zubenko A.D., Fedorova O.A.*

The A.N. Nesmeyanov Institute of Organoelement Compounds of Russian Academy of Sciences,  
Moscow, Russia  
PhD student  
[annbakhareva@yandex.ru](mailto:annbakhareva@yandex.ru)

Radiopharmaceuticals used for the treatment and diagnosis of cancer contain a radionuclide and a complexone. Targeted delivery of radionuclides to malignant tumors can be achieved by coupling with biological vectors, such as antibodies and peptides, which have an affinity for cancer cells [1]. The complexone binds the cation of the radioactive metal into a stable coordination complex, so that it can be delivered to the desired molecular target in the body [2]. Currently existing complexones are limited mainly by derivatives of the azacrown ester of DOTA and the acyclic ligand of DTPA, which have certain disadvantages, namely, slow complexation and kinetic lability.

The aim of this work is to develop optimal acyclic chelators suitable for use as components of radiopharmaceuticals. Thus, in the course of the work, 10 target complexones with a different number and type of chelating groups were synthesized (Figure 1).



**Figure 1.** Synthesized ligands.

Complexones **L1-L8** are based on a polyamine chain with additional chelating groups of different nature. To obtain these compounds, 15- and 18-membered azacrown compounds were synthesized by the macrocyclization reaction, into the structure of which chelating groups were inserted by the N-alkylation reaction. Upon acid hydrolysis, the macrocycle was destroyed and acyclic complexones were obtained. In this case, ligands **L5-L8** combine in their composition two types of chelating groups.

In complexones **L9** and **L10**, pyridine is the part of the polyamine chain and imparts structural rigidity to the molecule. These ligands were synthesized from dimethyl ether of pyridinedicarboxylic acid and 2,6-(dichloromethyl)-pyridine, respectively. In both cases, the reaction with ethylenediamine was carried out at the first stage, then the introduction of chelating groups and their hydrolysis.

The complexing properties of the obtained ligands were studied by various physicochemical methods of analysis. The stability constants were obtained with metal cations  $\text{Bi}^{3+}$ ,  $\text{Lu}^{3+}$ ,  $\text{Y}^{3+}$ ,  $\text{Cu}^{2+}$ ,  $\text{Zr}^{4+}$ ,  $\text{Ga}^{3+}$ .

## References

- [1] *J. Radioanal. Nucl. Chem.* **2019**, 321, 531-540.  
[2] *Molecules* **2013**, 18, 3379-3409.

Acknowledgements. This work was supported by the Russian Science Foundation (project No 21-73-20158).

# STEREOSELECTIVE SYNTHESIS OF DISPIROOXINDOLES THE POTENTIAL CANCER-TREATING AGENTS

*Shikut N.L.*<sup>1</sup>, *Barashkin A.A.*<sup>1</sup>, *Beloglazkina E.K.*<sup>1</sup>

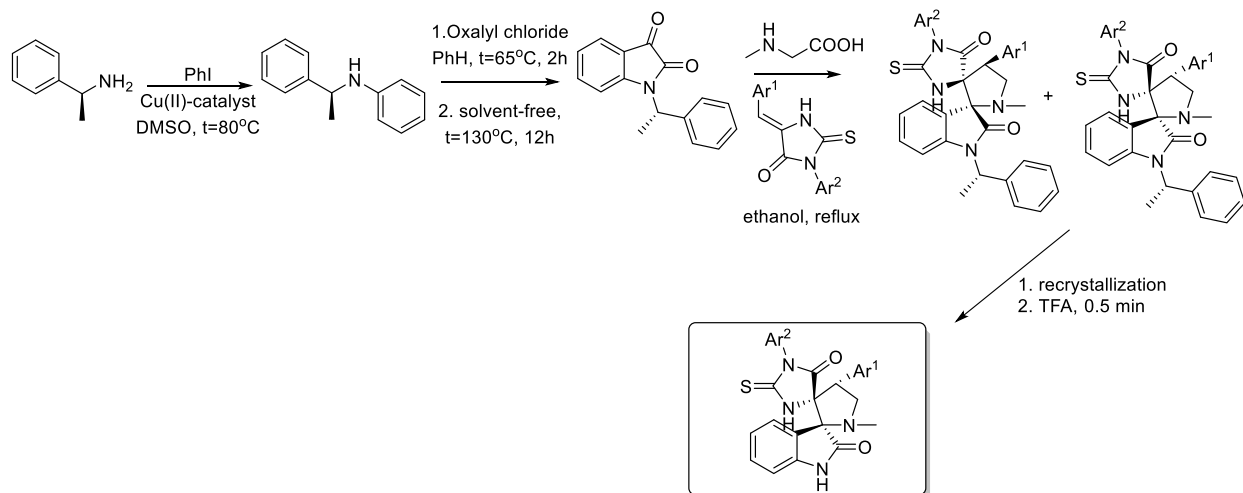
<sup>1</sup>Moscow State University, Department of Chemistry, Moscow, Russia  
Student

[nikita.shikut@chemistry.msu.ru](mailto:nikita.shikut@chemistry.msu.ru)

Dispirooxindoles show high antitumor activity as small-molecular inhibitors for different protein-protein interactions, e.g. p53-MDM2, c-MYC-MAX/DNA, etc. They can be easily obtained by 1,3-dipolar cycloaddition from simple compounds such as sarcosine, isatin, and 5-arylidene-2-thiohydantoin. In the resulting mixture of two enantiomers being formed, there is only one enantiomer that shows antitumor activity. [1] An important goal is to carry enantioselective synthesis out. It can be achieved by the chiral catalysis that does not give the required optical purity for target molecules despite the high yields. The second way examined in the present work was to modify precursors with easily removable chiral substituents. [2]

This approach allows to increase the content of one of the produced diastereomers and to facilitate the separation of the diastereomeric mixture (e.g. by recrystallization). After the diastereomers have been separated the chiral substituent can be easily removed to obtain the enantiomerically pure target compound.

The present work deals with the examination of various 1-phenylethyl substituents as such chiral agents. The 1<sup>st</sup> position in the isatin molecule and the 3<sup>rd</sup> position of 5-arylidene-2-thiohydantoin were modified to obtain the series of various dispirooxindoles. The formed diastereomeric mixtures were separated to get the individual diastereomers. The dispirooxindoles with enantiomeric excess up to 99% were obtained by the removal of the chiral substituents and were analyzed with several methods.



**Figure 1.** Scheme of the synthesis of enantiomerically pure dispirooxindoles.

## References

- [1] Beloglazkina A. et al. *Chem. Heterocycl. Compd.* **2020**, *56*, 747–755  
[2] Sallio R., Lebrun S. et al. *Beilstein J. Org. Chem.* **2018**, *14*, 593–602

Acknowledgements. This work was supported by the Russian Science Foundation (project No 21-13-00023) and Russian Foundation for Basic Research (project No 19-33-90237).

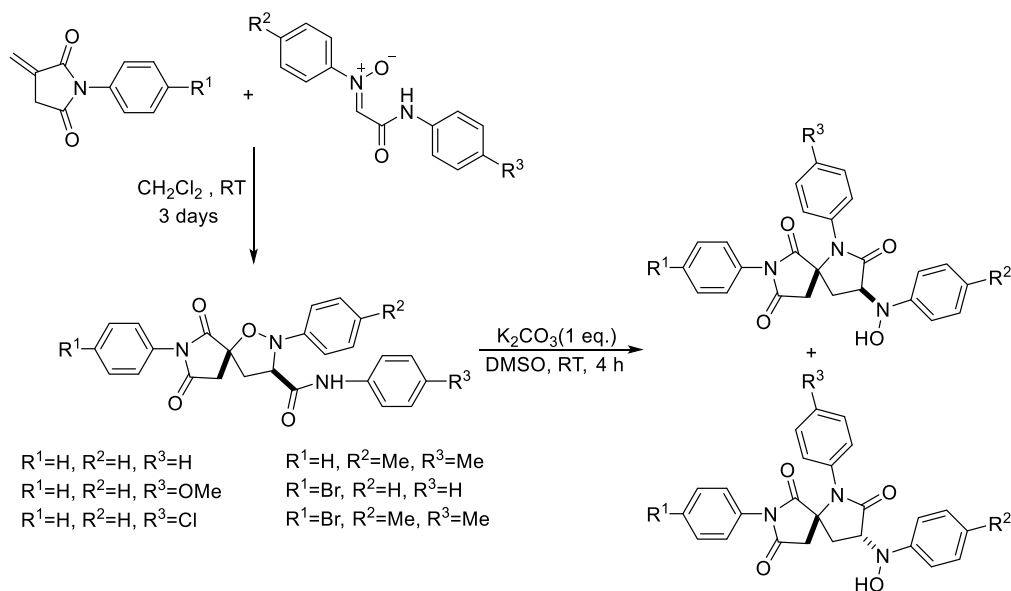
# NEW REARRANGEMENT OF ISOXAZOLIDINE-3-CARBOXAMIDES UNDER BASIC CONDITIONS

*Sirotkina E.V.*<sup>1</sup>, *Efremova M.M.*<sup>1</sup>, *Kuznetsov M.A.*<sup>1</sup>, *Molchanov A.P.*<sup>1</sup>

<sup>1</sup>Saint Petersburg State University, Saint Petersburg, Russia  
PhD student  
katya.sirotkina@mail.ru

Today 1,3-dipolar cycloaddition of nitrones to alkenes is one of the most universal and convenient methods for the synthesis of isoxazolidines [1]. The special interest is in research of new ways of synthetic application for the functionalized isoxazolidines, which are supposed to be perspective substrates for obtaining different classes of organic compounds, which were hard-accessible before [2]. It is known that the basic treatment of isoxazolidines suitably activated at the 3-position of the ring has been exploited for a general synthetic approach to furan-2(5*H*)-ones,  $\beta$ -enaminones or pyrrole-2,5-diones[3-4].

The aim of this work is to investigate the base-mediated rearrangement of isoxazolidines obtained by 1,3-dipolar cycloaddition of *N*-aryl-*C*-carbamoylnitrones to *N*-arylitaconimides.



**Figure 1.** Synthesis and reactions of isoxazolidine-3-carboxamides.

It was found that the cycloaddition reaction of *N*-aryl-*C*-carbamoylnitrones with *N*-arylitaconimides proceeds strictly regioselectively with high stereoselectivity to form mixture of diastereomeric isoxazolidines, with predominance of the isomer with *cis* relative configuration of the substituent at the C-3 position of isoxazolidine ring and the methylene group of the pyrrolidine ring. Optimal conditions have been found for the basic rearrangements of isoxazolidines. It was shown that the treatment of isoxazolidines with potassium carbonate leads to form mixture of diastereomeric hydroxylaminolactams.

## References

- [1] Reissig H.-U., Breugst M. *Angew. Chem. Int. Ed.* **2020**, *59*, 12293-12307
- [2] Berthet M., Cheviet T., Dujardin G., Parrot I. and Martinez J. *J. Chem. Rev.* **2016**, *116*, 15235–15283
- [3] Iannazzo D. et. al *Eur. J. Org. Chem.* **2010**, *30*, 5897–5905
- [4] Iannazzo D. et. al *Synlett* **2011**, *2*, 245–248

Acknowledgments. NMR, HRMS and XRD studies were performed at the Saint Petersburg State University Center for Magnetic Resonance, Center for Chemical analysis and materials research and X-Ray Diffraction Center, respectively.

MOLECULAR EVOLUTION OF THE REGULATORY REGION AND PROMOTER  
OF A HIGHLY CONSERVED GENE

*Sivoplyas E.A.*<sup>1</sup>, *Kulikov A.M.*<sup>2</sup>

<sup>1</sup>Moscow Pedagogical State University (MPGU), Moscow, Russia

<sup>2</sup>Koltzov Institute of Developmental Biology of Russian Academy of Sciences, Moscow, Russia

PhD student

[sivoplyas-ekater@mail.ru](mailto:sivoplyas-ekater@mail.ru)

The *Dras1* gene is the most well known proto-oncogene. Most research of carcinogenesis showed the participation of Ras family genes in the formation of malignant tumors. The *Dras1* gene is an ortholog of human genes (*N-ras*, *K-ras* and *H-ras*) and belongs to the highly conservative gene: the nucleotide sequence is little variable from yeast to human. These genes were first discovered in rat sarcoma cells which led to the name of this group. RAS genes are involved in the regulation of cell division, normal and in pathologies. Mutation of these genes is found in nearly 15% of all cases of tumors of human tumor formation.

The *Dras1* gene and the protein produced by it belongs to the ras superfamily. Their participation in signal transmission from cell receptors to the MAR-kinase cascade is shown. In addition to this function, proteins in this family affect the state of the actin cytoskeleton, malignant transformation and other processes. However, data on the regulation of the gene's own transcriptional activity are very little known. The involvement of miRNAs in regulating gene expression activity of orthologous ras gene has previously been shown to man. This process includes the participation of 17 microRNAs. For *Drosophila*, the influence of miRNAs on the expression of oncogenes previously was not shown. For invertebrates, data were obtained only for *Caenorhabditis elegans*.

1. Production of transgenic structures bearing the GFP reporter gene under the Heat Shock promoter, containing a 3'- untranslated region of the *Dras1* gene with the presence / absence of the analyzed conservative sequence.

2. Getting transgenic flies.

3. Analysis of the degree of GFP reporter gene expression using a confocal laser microscope.

4. Expression score

**Results:** Were found sites of binding of miRNA (mir-313, mir-92a, mir-312) with the investigated gene *Dras1* in the region 3'-UTR.

Made transgenic construct containing the *GFP* gene and the 3'UTR of the *Dras1* gene in *D. melanogaster* with the presence / absence of the analyzed conservative sequence.

Were obtained transgenic flies.

Was analyzed the degree of gene expression.

*Dras1* is one of the most important housekeeping genes, functioning as a key component of the promitotic regulatory cascades. The gene product is involved in signal transduction from the receptor tyrosine kinases to transcription factors - the cell cycle regulators. Therefore, this gene is highly conserved, and most of non-neutral substitutions are discarded by selection leaving for analysis only neutral variability.

It is shown that the change of the transcription start site and the nucleotide sequence of the regulatory region of the gene in the early stages of the evolution of species from around the subgenus *Drosophila*.

#### References

[1] Alonso-González L, Domínguez A, Albornoz J. Direct determination of the influence of extreme temperature on transposition and structural mutation rates of *Drosophila melanogaster* mobile elements. *Genetica*. 2006 Sep-Nov;128(1-3):11-9.

[2] Golubovskiy M.D. The «lethal giant larvae» the most frequent second chromosome lethal in natural populations of *Drosophila melanogaster* // *Drosophila Inform. Serv.* 1978. V. 53. P.79

[3] Evgen'ev MB, Zelentsova H, Poluectova H, Lyozin GT, Veleikodvorskaja V, Pyatkov KI, Zhivotovsky LA, Kidwell MG. Mobile elements and chromosomal evolution in the virilis group of *Drosophila*. *Proc Natl Acad Sci U S A*. 2000 Oct 10;97(21):11337-42.

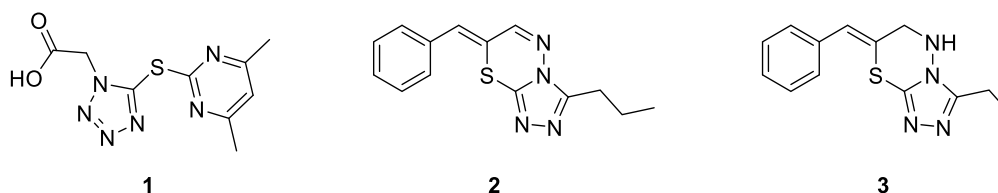
Acknowledgements. This work was supported by the Russian Foundation for Basic Research (project No 16-34-00840 mol a).

ANNELATED AND NON-ANNELATED TETRAZOL-, TRIAZOL- AND PYRIMIDINE-CONTAINING HETEROCYCLIC SYSTEMS AS POTENTIAL ACTIVE INGREDIENTS OF ANTIVIRAL DRUGS

*Skryl'nikova M.A.*<sup>1</sup>, *Shmaneva N.T.*<sup>1</sup>, *Sinegubova E.O.*<sup>2</sup>, *Khramchikhin A.V.*<sup>1</sup>, *Pavlyukova Yu.N.*<sup>1</sup>, *Zarubaev V.V.*<sup>2</sup>, *Ostrovskii V.A.*<sup>1</sup>

<sup>1</sup>Saint Petersburg State Institute of Technology (Technical University), Saint Petersburg, Russia  
<sup>2</sup>Saint Petersburg Pasteur Research Institute of Epidemiology and Microbiology, Saint Petersburg, Russia  
 PhD student  
[mari954@mail.ru](mailto:mari954@mail.ru)

The events of 2020 showed an urgent need for the development of drugs against viral infections. Non-fused pyrimidine derivatives, which are key pharmacophore fragments of modern antiviral drugs (stavudine, zalcitabine, etc.), are widely known. The tetrazolyl pharmacophore fragment is actively used in the molecular design and synthesis of promising antiviral agents [1]. Recently, annelated heterocyclic systems based on a triazole ring have also become of interest. Thus, it has recently been shown that triazavirin, 7-(methylthio)-3-nitro- [1,2,4]triazolo[5,1-c]triazin-4(1H)-one, is effective for the treatment of new coronavirus infection and is well tolerated by patients with COVID-19 [2]. In this way it seems important to synthesize and study the properties of both annelated and unannulated scaffolds containing tetrazole, triazole, and pyrimidine fragments.



**Figure 1.** Synthesized compounds

For the previously not described compounds synthesized in this study the structure and individuality have been established, and the *in vitro* antiviral activity against the influenza A (H1N1) virus has been studied. The selectivity index (SI) for these substances exceeds the SI value of the reference (rimantadine) (Table 1).

**Table 1.** *In vitro* research

Compound No	<b>1</b>	<b>2</b>	<b>3</b>	<b>Rimantadine</b>
CC50, $\mu\text{mol}$	>1100	>300	>300	310
IC50, $\mu\text{mol}$	116	9.1	16	61
SI	10	33	19	5

Annelated triazolothiadiazine class compounds **2** and **3** have shown the best results and can therefore serve as prototypes of potential new antiviral drugs with a wide spectrum of activity.

**References**

- [1] Popova E.A., Trifonov R.E., Ostrovskii V.A. *Russ. Chem. Rev.* **2019**, 88 (6) 644-676  
 [2] Sabitov, A.U.; Belousov, V.V. and others. *Antibiotiki i Khimioter.* **2020**, 65, 7-8, 27

Acknowledgements. This work was supported by Russian Foundation for Basic Research (project No 20-53-05010 *Arm\_a*).

## CYCLIC VOLTAMMETRY IN BLOOD PLASMA ON PLATINUM SINGLE-CRYSTAL ELECTRODES

Sokolova A.A.<sup>1</sup>, Goroncharovskaya I.V.<sup>2</sup>, Rudnev A.V.<sup>3</sup>, Molodkina E.B.<sup>3</sup>, Ehrenburg M.R.<sup>3</sup>, Evseev A.K.<sup>2</sup>,  
Shabanov A.K.<sup>2</sup>

<sup>1</sup>Mendeleev University of Chemical Technology, Moscow, Russia

<sup>2</sup>N.V. Sklifosovsky Research Institute for Emergency Medicine, Moscow, Russia

<sup>3</sup>A.N. Frumkin Institute of Physical Chemistry and Electrochemistry of RAS, Moscow, Russia

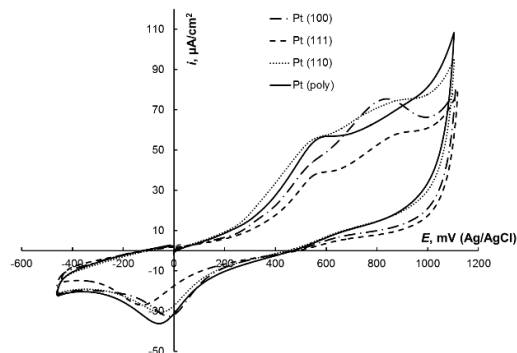
Student

[goririna22@gmail.com](mailto:goririna22@gmail.com)

**Introduction:** Determination of the antioxidant activity (AOA) of blood plasma or serum in critically ill patients is an urgent task, since this indicator reflects the level of oxidative stress [1]. Electrochemical methods for assessment of AOA in biological media, in particular, cyclic voltammetry, have a number of advantages over traditional methods. Another important task is the search for new electrode materials for such measurements to increase their sensitivity and selectivity. A promising direction for the development of composite electrodes is the use of noble metal nanoparticles (NPs), in particular Pt NPs, as they have a high catalytic activity [2]. In addition, the catalytic activity of NPs is also influenced by the structure of their surface (shape-controlled NPs with preferential crystallographic surface orientation). Thus, the aim of this work was to study the effect of the crystallographic orientation of the surface of Pt (hkl) single crystals on the process of electrooxidation of low molecular weight antioxidants in blood plasma.

**Methods:** Cyclic voltammograms (CVs) were measured in blood plasma in a three-electrode cell at a potential sweep rate of 10 mV/s. Platinum single-crystal electrodes (Pt(100), Pt(111), Pt(110)) and a polycrystalline platinum electrode, Pt(poly), were used as working electrodes. Electrode preparation was carried out following the method described in [3].

**Results:** CVs of Pt(poly) and single-crystal Pt electrodes in the blood plasma show two electrooxidation waves at potentials of ca. 500 mV and 800 mV, which, according to the literature, corresponds to the electrooxidation of low molecular weight antioxidants: ascorbic and uric acids in the first the case and lipoic acid and  $\alpha$ -tocopherol in the second case [4]. It has been shown that the process of electrooxidation of antioxidants in blood plasma is structurally sensitive (Fig. 1). Although the oxidation currents of antioxidants are lower on Pt (111) than on Pt (poly), the two waves of electrooxidation are much more pronounced in CV of Pt (111), as compared to that of Pt (poly). On Pt (100), the height of the oxidation wave of ascorbic and uric acids (500 mV) is lower than on Pt (poly), while the oxidation wave of lipoic acid and  $\alpha$ -tocopherol (800 mV) on Pt(100) is the highest and most pronounced in comparison with other electrodes, which indicates a higher electrocatalytic activity of the (100) face in this process.



**Figure 1.** CVs of Pt electrodes in blood plasma.

**Conclusions** Thus, based on our data, it can be concluded that Pt electrodes with surface orientation (100) and (111) are of greatest interest for assessing the antioxidant activity of blood plasma by the CV method. A promising direction in the future will be the synthesis of shape-controlled Pt NPs with preferential (100) and (111) face orientation.

### References

- [1] *Electroanalysis* **2021**, 33, 550-557
- [2] *Biosens. Bioelectron.* **2018**, 103, 113-129
- [3] *J. Electroanal. Chem.* **2017**, 802, 109-117
- [4] *Signals* **2021**, 2, 138-158

**Acknowledgements.** The work was supported by the Ministry of Science and Higher Education of the Russian Federation.



FIRST 3D HALOGEN-BONDED ORGANIC FRAMEWORK (XOF) BASED  
ON ZWITTERIONIC IODONIUM SALTS

*Soldatova N.S.*<sup>1,2</sup>, *Ivanov D.M.*<sup>2</sup>, *Postnikov P.S.*<sup>1</sup>

<sup>1</sup> Tomsk Polytechnic University, Tomsk, Russia

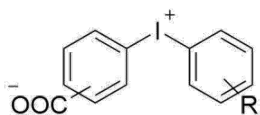
<sup>2</sup> Saint Petersburg State University, Saint Petersburg, Russia

Young scientist

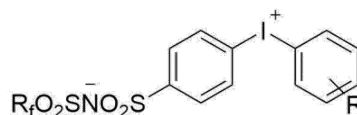
[SoldatovaNS@tpu.ru](mailto:SoldatovaNS@tpu.ru)

In the last several years, the iodonium salts attract more and more attention as halogen bonding (XB) donors [1–3]. Among diaryliodonium salts, zwitterionic compounds are of particular interest for supramolecular chemistry due to their ability to form complex aggregation as 1D chains or 2D layers [4,5].

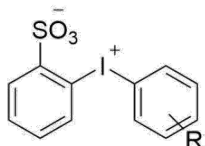
**Previous works**



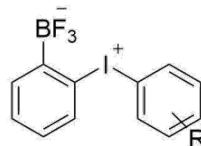
Beringer, F. M. & Lillien, I., 1960  
Luis, S. V. et al, 1989



DesMarteau, D. D. et al, 2003

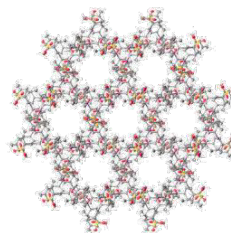
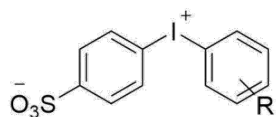


Updegraff, J. B. et al, 2009



Legault, C. Y. et al, 2017

**This work**



**3D XOF bearing hexagonal pores**

**Figure 1.** The XOFs based on zwitterionic iodonium salts

In this study, we developed a synthesis of novel 4-(aryliodonio)-benzenesulfonates with Oxone as an oxidant. Synthesis and crystallization of 3D XOF were scaled up to 0.5 gram and properties of obtained material was study.

**References**

- [1] Catalano L. et al., *Hypervalent Iodine Chemistry*. **2016**, 289-309
- [2] Heinen F. et al. *Angew. Chem. Int. Ed.* **2018**, 57, 3830-3833
- [3] Heinen F. et al. *J. Am. Chem. Soc.*, **2020**, 142, 8633-8640
- [4] Justik, M. W et al, *Tetrahedron Lett.*, **2009**, 50, 6072–6075
- [5] DesMarteau, D. D., et al *J. Fluor. Chem.*, **2003**, 122, 57–61

Acknowledgements. This work was supported by "Mega-grant" project, application number 2020-220-08-8827.

## ARYLNITRILE OXIDES IN REACTIONS WITH AZABICYCLO[2.2.1]HEPTANE DERIVATIVES

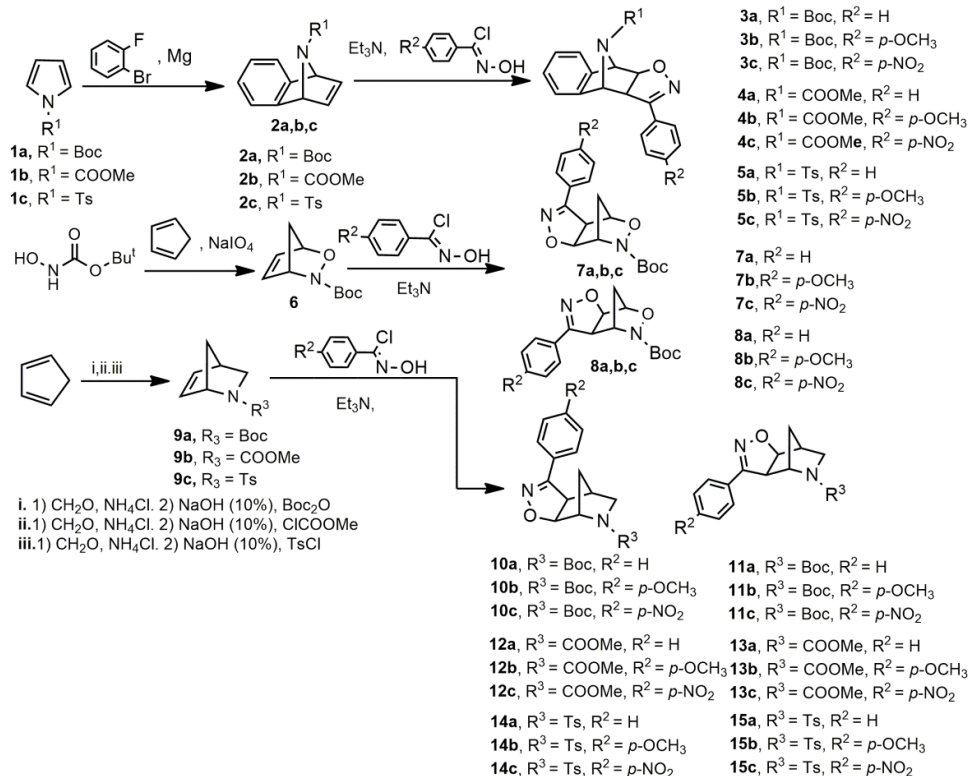
*Solodovnikova T.A., Yakupova L.R., Gavrilova A.Yu., Zyk N.V.*

Moscow State University, Moscow, Russia

PhD Student

[ts15.01.1995@yandex.ru](mailto:ts15.01.1995@yandex.ru)

The bridged azabicyclic structural fragment is the core element in a large number of natural products and bioactive compounds. 1,3-Dipolar cycloaddition reaction is an effective way for modifying an unsaturated bond. Thus, cycloaddition of nitrile oxides generated *in situ* leads to the formation of an isoxazoline ring which is a hidden equivalent of some functional groups that can be used at the corresponding synthesis stage [1].



**Figure 1.**

We have studied the direction of 1,3-dipolar addition reaction of the aromatic nitrile oxides to the derivatives of 2-azabicyclo[2.2.1]heptanes, 7-azabicyclo[2.2.1]heptanes and 2-oxa-3-azabicyclo[2.2.1]heptanes. For this purpose the synthesis of bicyclic alkenes was carried out according to the described methods [2]. The synthesis of the derivatives containing an electron-withdrawing substituent included two stages: the interaction of cyclopentadiene with imine formed *in situ* led to the formation of unsubstituted product which was acylated at the second stage. The 2-oxa-3-azabicyclo[2.2.1]heptane was synthesized from *N*-*tert*-butoxycarbonylhydroxylamine and cyclopentadiene.

Then, the phenyl nitrile oxide, the *p*-methoxyphenyl nitrile oxide and the *p*-nitrophenyl nitrile oxide were chosen as 1,3-dipoles, which were generated *in situ* by the reaction of substituted chlorobenzaldoximes with triethylamine.

As a result of the reaction of the aromatic nitrile oxides with bicyclic derivatives, a mixture of regioisomers was obtained exclusively with the *exo* arrangement of the isoxazoline ring. The *exo* arrangement of the isoxazoline ring was proved by <sup>1</sup>H NMR spectroscopy. The *endo*-arrangement of protons is evidenced by the value of their spin-spin coupling constant of 8 Hz.

#### References

- [1]. Pandey G., Lakshmaiah G. *Tetrahedron Letters* **1993**, 34, 7301-7304
- [2]. Grieco P.A., Larsen S.D. *Org.Synth.* **1990**, 68, 206

# SYNTHESIS OF FLUORESCENT DBMBF<sub>2</sub>-BASED MARKERS FOR DETERMINING OF SILANOL GROUPS

*Sorokin D.A.*<sup>1,2</sup>, *Kononevich Yu.N.*<sup>2</sup>, *Belova A.S.*<sup>2</sup>, *Ershova T.O.*<sup>2</sup>, *Anisimov A.A.*<sup>2</sup>, *Muzafarov A.M.*<sup>2</sup>

<sup>1</sup>D.I. Mendeleev University of Chemical Technology of Russia, Moscow, Russia

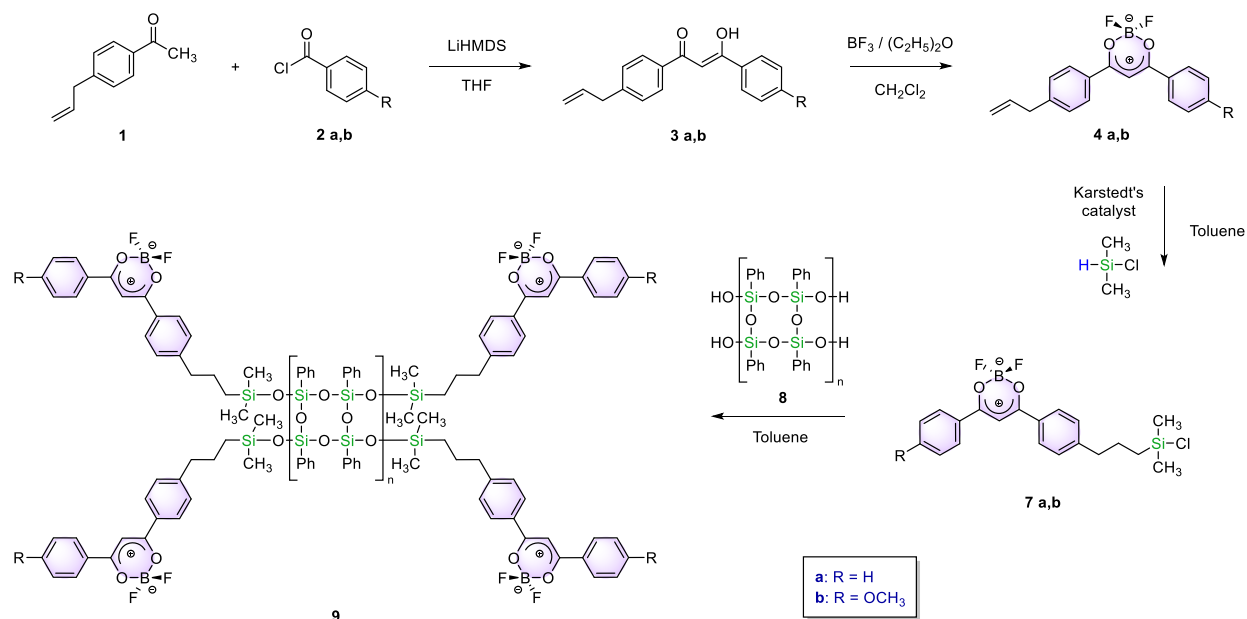
<sup>2</sup>A.N. Nesmeyanov Institute of Organoelement Compounds,  
Russian Academy of Sciences, Moscow, Russia

Student

[mr.dmit1999@gmail.com](mailto:mr.dmit1999@gmail.com)

Polysiloxanes are widely used polymers with such valuable properties as recyclability, low toxicity, biocompatibility, etc., that allow them to occupy a unique niche among special purpose materials, for example, materials for biomedical applications, covers, rubbers and other. During the preparation process of these polymers it can remain unreacted functional silanol groups, in particular, terminal ones. Among the methods for determining of residual silanol groups the most sensitive is the using of fluorescent markers. Between wide variety of fluorescent markers, it should be highlighted the dibenzoylmethanate boron difluoride (DBMBF<sub>2</sub>) derivatives. These dyes are widely used in numerous studies related to optical materials, aggregation-induced emission, mechanochromic materials, solar cells and chemical sensing due to their valuable photophysical properties, such as strong fluorescence in both solution and solid state, large extinction coefficients, tunable emission, and the ability to form intensively fluorescent excimers and exciplexes.

In this work, we describe the synthesis of functional fluorescent markers based on DBMBF<sub>2</sub> derivatives which can be utilized for labelling of residual silanol groups in ladder polyphenylsilsesquioxane (PPSQ) as well as in other polysiloxanes. Structures of synthesized compounds were confirmed by IR, <sup>1</sup>H, <sup>13</sup>C, <sup>19</sup>F, <sup>29</sup>Si NMR spectroscopy and mass-spectrometry (ESI).



**Figure 1.**

Acknowledgements. This study was supported by the Russian Science Foundation (grant no. 18-73-10152).

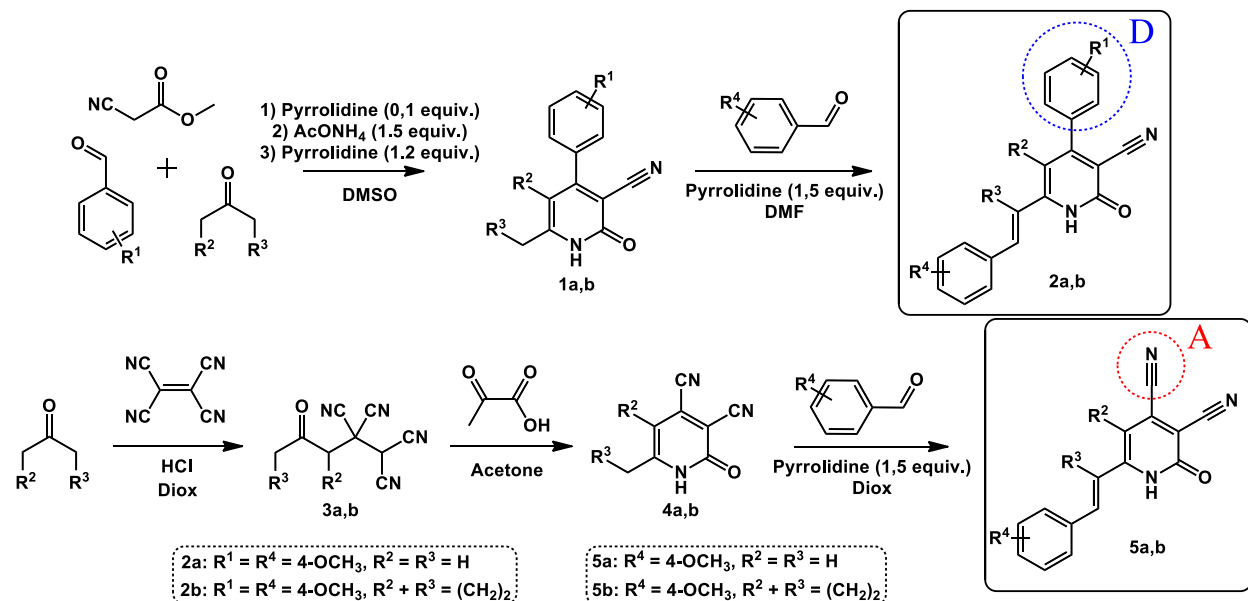
Chuvash State University named after I. N. Ulyanov, Cheboksary, Russia

Student

[ssp\\_9999@mail.ru](mailto:ssp_9999@mail.ru)

Currently, the synthesis of cyano-substituted organic compounds is one of the rapidly developing directions in organic chemistry [1]. Functionalization of pyridine derivatives, in particular nicotinonitriles, plays a significant role in medicinal chemistry and cyano-substituted chromophores are used in many fields of science and technology [2-3].

Herein, the synthesis of new cyano-substituted pyridones **2** and **5** differing from each other by the substituent in the fourth position of the pyridine cycle is reported (Figure 1).



**Figure 1.** Synthesis of styrylpyridones

The preparation of pyridones **2** proceeds as follows: at the first stage, pyridines **1** are synthesized by the three-component method using methyl cyanoacetate with arylaldehydes and ketones of various structure. The final stage of obtaining the target pyridones is based on the condensation of compounds **1** with the corresponding aromatic aldehydes in the pyrrolidine-DMF system.

The synthesis of pyridones **5** is based on the initial preparation of 4-oxoalkane-1,1,2,2-tetracarbonitriles **3**. Their further heterocyclization to pyridones **4** and interaction with aromatic aldehydes afford the desired products.

The study of the fluorescent properties of the compounds **2** showed that they exhibit fluorescence in the solid state. It was found that the introduction of substituents of different nature and their arrangement in the aromatic moieties' rings make it possible to vary solid-state fluorescence wavelength from 500 to 600 nm.

In contrast to pyridones **2** the pyridone derivatives **5** are not fluorescent in the aggregated state. The fluorescence of pyridones **2** and **5** was compared in various solvents.

### References

- [1] Liu, J., Hou, W., Feng, S., Qiu, L., Liu, X., & Zhen, Z. *Journal of Physical Organic Chemistry* **2011**, 24, 439–444.
- [2] Shestopalov, A. M., Rodinovskaya, L. A., Shestopalov, A. A., Gromova, A. V., Fedorov, A. E., & Gakh, A. A. *American Chemical Society* **2009**, 1003, 263-280.
- [3] Jeux, V., Segut, O., Demeter, D., Rousseau, T., Allain, M., Dalinot, C., Sanguinet, L., Leriche, P., & Roncali, J. *Dyes and Pigments* **2015**, 113, 402–408.

# SYNTHESIS OF SUBSTITUTED OXIMES: UMPOLUNG OF ENAMINES IN REACTION BETWEEN (SILOXY)ENAMINES AND ORGANOMETALLIC COMPOUNDS

*Sovdagarova E.R.*<sup>1,2</sup>, *Sukhorukov A.U.*<sup>1,3</sup>

<sup>1</sup>Zelinskiy Institute of Organic Chemistry of Russian Academy of Sciences, Moscow, Russia

<sup>2</sup>Moscow State University, Moscow, Russia

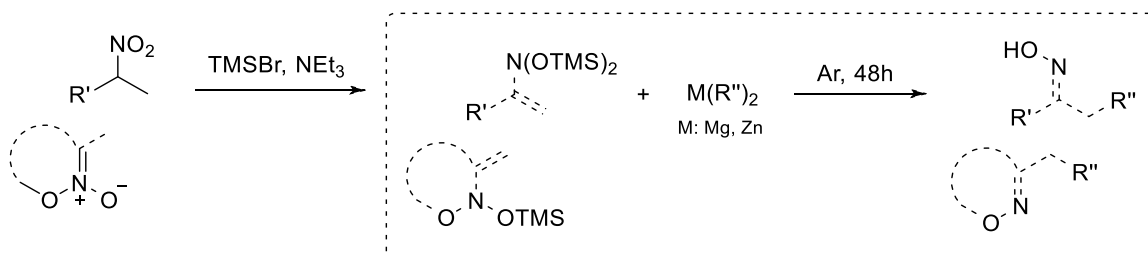
<sup>3</sup>Plekhanov Russian University of Economics, Moscow, Russia

Student

[liza.sovdagarova@gmail.com](mailto:liza.sovdagarova@gmail.com)

Oximes have found a broad range of application both in organic synthesis and applied chemistry. The oxime function is readily transformed into carbonyl, nitro, cyano groups, substituted heterocycles. These compounds have shown a variety of biological activities, such as antivirus, antibacterial, anti-inflammatory, anticancer and others. By that we can confidently state that synthesis of substituted oximes is a question of current interest in organic chemistry. [1]

Our group offers new approach towards synthesis of substituted oximes, which is based on reaction between (siloxy)enamines and organometallic compounds. Here (siloxy)enamines show umpolung properties in reference to enamines, which are  $\beta$ -nucleophiles. Weakening of N-O bond by presence of OTMS groups leads to shifting of electron density towards nitrogen atom making N,N-bis(siloxy)enamines  $\beta$ -electrophiles [2]. Formation of a new C-C bond leads to wide variety of substituents.



**Figure 1.** Reaction

Mainly acyclic N,N-bis(siloxy)enamines with aliphatic and aromatic subsistence was studied. The reaction was also carried out with (siloxy)esters of cyclic nitronates. As for organometallic compounds, two types of reagents were tested: Grignard reagents and zinc organic compounds. Reaction proceeds in mild condition with moderate yields.

## References

[1] D. S. Bolotin, N. A. Bokach, M. Y. Demakova, V. Yu. Kukushkin, *Chem. Rev.*, **2017**, *117*, 13039

[2] A. Yu. Sukhorukov, A. D. Dilman, Tabolin A. A., Ioffe, S. L. *Synthesis*, **2017**, *49*, 3255

Acknowledgements. This work was supported by the support system of the Russian Federation President Grant (project No МД-1312.2020.3)

REACTIONS OF 4-PYRONES WITH AZOMETHINE YLIDES AS A CHEMOSELECTIVE METHOD FOR THE CONSTRUCTION OF MULTISUBSTITUTED PYRANO[2,3-C]PYRROLIDINES

*Stebekov V.D., Obydenov D.L., Sosnovskikh V.Y.*

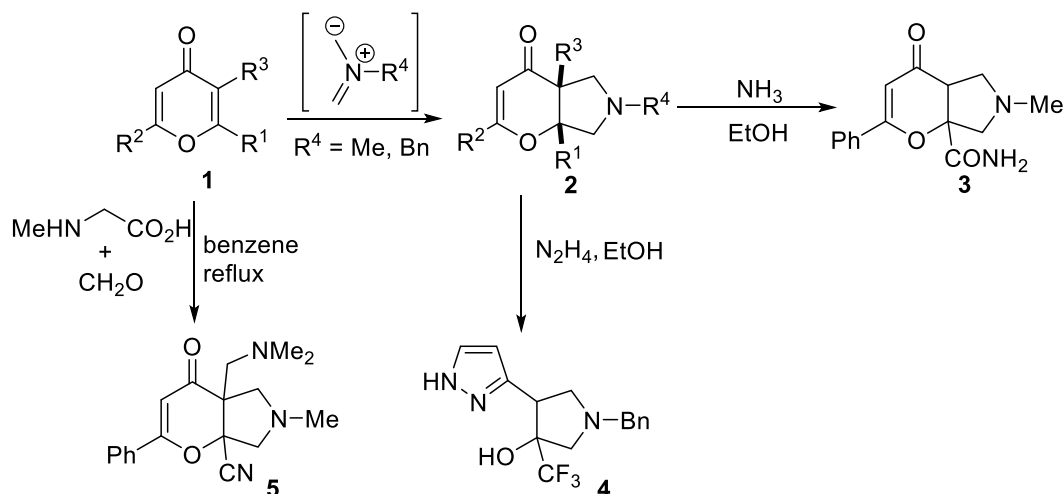
Ural Federal University, Ekaterinburg, Russia  
PhD Student  
[v.d.stebekov@mail.ru](mailto:v.d.stebekov@mail.ru)

4-Pyranones, also known as 4-pyrones, contain two double bonds of different nature, which allows them to react with 1,3-dipoles to form a wide range of products. It is well known that the reaction of [3+2]-cycloaddition of azomethine ylides with alkenes activated by electron-withdrawing groups is a modern method for the synthesis of pyrrolidine derivatives. In the work of M. Rudas [1], pyrano[2,3-c]pyrrolidines were already obtained as a result of [3+2]-cycloaddition reaction, but their number remained limited, and the chemical properties were not studied. Some compounds bearing the both pyran and pyrrolidine moieties are well known as bioactive natural alkaloids such as elaeocarpine and rubrobramide, so pyrano[2,3-c]pyrrolidines are of interest for medicinal chemistry.

It was found that pyrones **1** are able to react with azomethine ylides generated from paraform and sarcosine, or from *N*-benzyl-1-methoxy-*N*-((trimethylsilyl)methyl)methanamine, to form cycloadducts **2**. This transformation proceeds with high chemoselectivity at the double bond activated by electron-withdrawing substituents [2].

In addition, the reactivity of the obtained cycloadducts was studied. Amidation of compounds **2** bearing the ester group with ammonia gave amide **3**, which are inaccessible for direct synthesis due to low solubility. The reaction of pyrano[2,3-c]pyrrolidines **2** with hydrazine proceeded with opening of the pyran ring and led to pyrazole **4**. In the case of 6-phenyl-4-pyrone-2-carbonitrile, product **5** was obtained as a result of the Mannich reaction following cycloaddition.

For an explanation of the reactivity of pyrones and the selectivity of the cycloaddition, DFT calculations were carried out to estimate the steric and electronic factors with the use of Fukui function analysis and frontier orbitals theory. It was found that the outcomes of the product are connected with the electrophilicity of the 4-pyrones, determined by the energy level of the lowest unoccupied molecular orbital (LUMO).



**Figure 1.** Obtaining pyrano[2,3-c]pyrrolidines **2** and their reactivity

**References**

- [1] Rudas M., Fejes I., Nyerges M. [et al.] *Chem. Soc., Perkin Trans. 1* **1999**, 1167–1172  
[2] Obydenov D.L., Stebekov V.D., Obydenov K.L. [et al.] *Synthesis* **2021**, 53, DOI: 10.1055/s-0040-1706032

Acknowledgements. This work was supported by the Russian Science Foundation (project No 18-13-00186).

SYNTHESIS AND ANTITUMOR ACTIVITY OF DIALKYLAMINE DERIVATIVES  
OF NATURAL PHAEOSPHAERIDE A

*Suponina D.S.*<sup>1</sup>, *Zakharenkova S.A.*<sup>1</sup>, *Abzianidze V.V.*<sup>1</sup>, *Moiseeva N.I.*<sup>2</sup>, *Krivorotov D.V.*<sup>1</sup>, *Trishin Yu.G.*<sup>3</sup>

<sup>1</sup> Research Institute of Hygiene, Occupational Pathology and Human Ecology, 188663, Leningrad region, Vsevolozhsky district, Kuzmolovo, Capitolovo station, Russian Federation

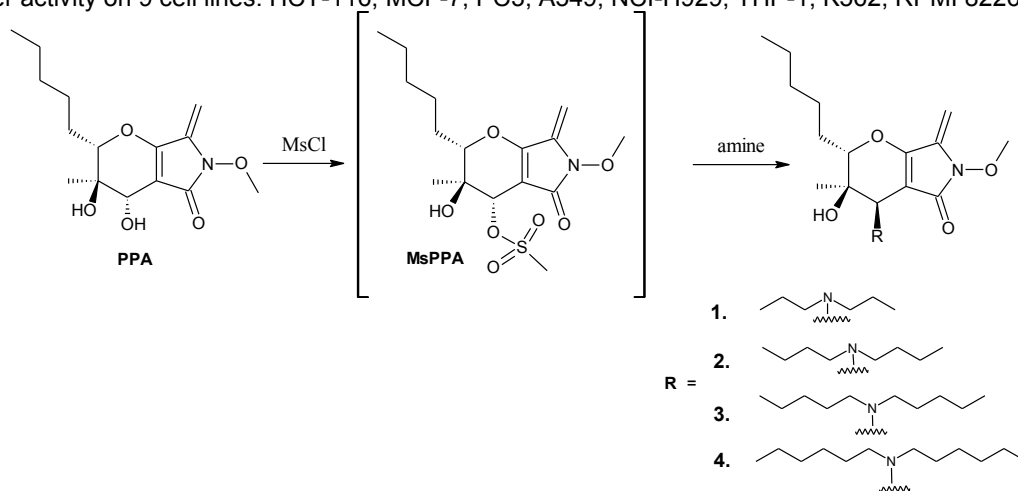
<sup>2</sup>N.N. Blokchin National Medical Research Center of Oncology, 115478, Moscow, Russian Federation

<sup>3</sup> St. Petersburg State University of Industrial Technologies and Design, 198095, St. Petersburg, Russian Federation

[Dina.lykina.97@mail.ru](mailto:Dina.lykina.97@mail.ru)

About 40% of anticancer drugs approved by the FDA are of natural origin or are semisynthetic derivatives of natural compounds, and considering synthetic substances - analogs of natural substances, their part reaches 70%.

We have synthesized dialkylamino derivatives of natural phaeosphaeride A [1] **1 - 4** and evaluated their anticancer activity on 9 cell lines: HCT-116, MCF-7, PC3, A549, NCI-H929, THP-1, K562, RPMI 8226, Jurkat.



**Table 1.** IC<sub>50</sub> values for the respective compounds when studied on the suspension and adhesive cell lines.

Compound	Adhesive cell cultures, IC <sub>50</sub> (μM)					Suspension cell cultures, IC <sub>50</sub> (μM)				
	HCT-116	MCF-7	PC3	A549	HEK293	NCI-H929	THP-1	K562	RPMI 8226	Jurkat
<b>PPA</b>	48	19	35	42	10	6.7	18	25	8.1	12
<b>2</b>	12	7,4	9,4	23	8,2	2,9	8,2	6,5	6,3	3,7
<b>Etoposide</b>	14	8,9	27	14	1,1	1,1	1,6	7,6	5,8	-

Compound **2** was found to be more active than the parent phaeosphaeride A on 9 cancer lines.

**Reference**

1. K. Maloney et al, *Org. Lett.*, **2006**, 8, 18, 4067 – 4070.

PREDICTION OF CATALYTIC ACTIVITY OF AZOLIUM-BASED HALOGEN BOND DONORS:  
AN EXPERIMENTALLY VERIFIED THEORETICAL STUDY

*Sysoeva A.A.<sup>1</sup>, Novikov A.S.<sup>1</sup>, Il'in M.V.<sup>1</sup>, Suslonov V.V.<sup>1</sup>, Bolotin D.S.<sup>1</sup>*

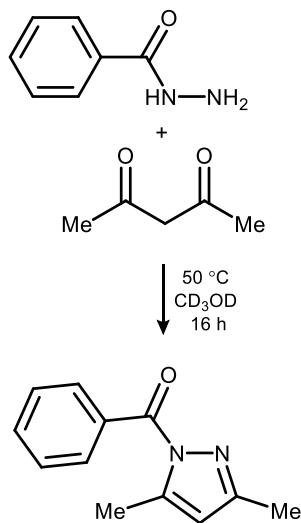
<sup>1</sup>Saint Petersburg State University, Saint Petersburg, Russia

Student

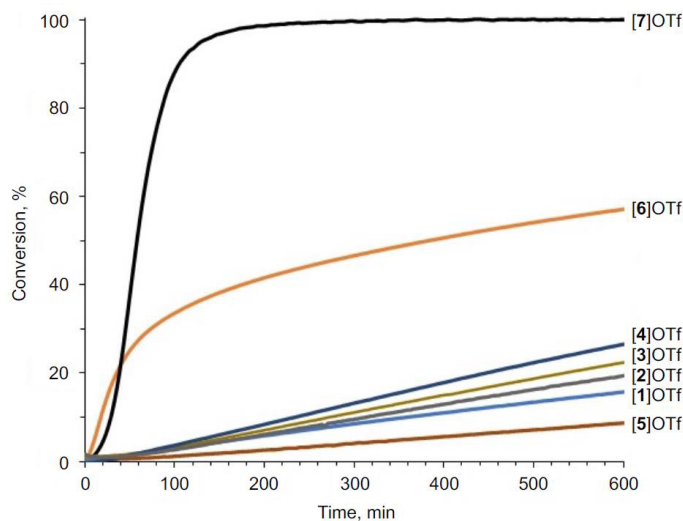
[sysoewa.alexandra.5@yandex.ru](mailto:sysoewa.alexandra.5@yandex.ru)

During the last decade, significant attention has been focused on study of new type organocatalysts, because they have remarkable advantages over metal-containing catalysts including low sensitivity to moisture and air, lower toxicity, and a reduced environmental footprint [1]. It was shown, that halogen bond donors can be served as organocatalysts, but this type of their activity is little explored [2,3]. This work is devoted to the study of the effect of the structure of halogen bond donors on their catalytic activity.

In this work we studied azolium salts as activity of some of them has been studied previously in a series of organic transformations (iodine-containing imidazoliums, 1,2,3- and 1,2,4-triazoliums). For generality, we also included in our study all other types of iodoazoliums and provided calculations of the distribution of the electrostatic surface potential. After that DFT calculations were carried out for determination of the activation energies of model reactions including halogen abstraction and carbonyl activation. Strong correlation ( $R^2 > 0.97$ ) was observed between the positive electrostatic potential on the  $\sigma$ -hole on the halogen atom and the Gibbs free energy of activation. The obtained results were confirmed experimentally by checking the catalytic activity of iodinated pyrazolium salts ([1-5]OTf), imidazolium salt ([6]OTf) and triazolium salt ([7]OTf) in the model Knorr-type reaction required carbonyl activation (**Figures 1 and 2**).



**Figure 6.** Model Knorr-type reaction.



**Figure 7.** <sup>1</sup>H NMR monitoring of the Knorr-type reaction.

It was shown in this work that ESP distribution calculations can predict the relative catalytic activity of structurally similar XB donors, due to the availability of correlation between the positive electrostatic potential on the  $\sigma$ -hole on the halogen atom and the Gibbs free energy of activation of the reaction. This observation reduces the computer and human resources in the prediction of the relative activity of XB donors by the ESP analysis in compare with the providing DFT calculations.

#### References

- [1] Oliveira V., Kraka E., Cremer D., *Inorg. Chem.*, **2017**, *56*, 488–502.
- [2] Cavallo G. et al., *Chem. Rev.*, **2016**, *116*, 2478–2601.
- [3] Sutar R.L., Huber S.M. *ACS Catal.*, **2019**, *9*, 9622–9639.

**Acknowledgements.** The theoretical calculations and kinetic part of this work were supported by the Russian Science Foundation (grant 20-73-10013), whereas the synthetic part was provided by the Russian Foundation for Basic Research (grant 19-03-00044).



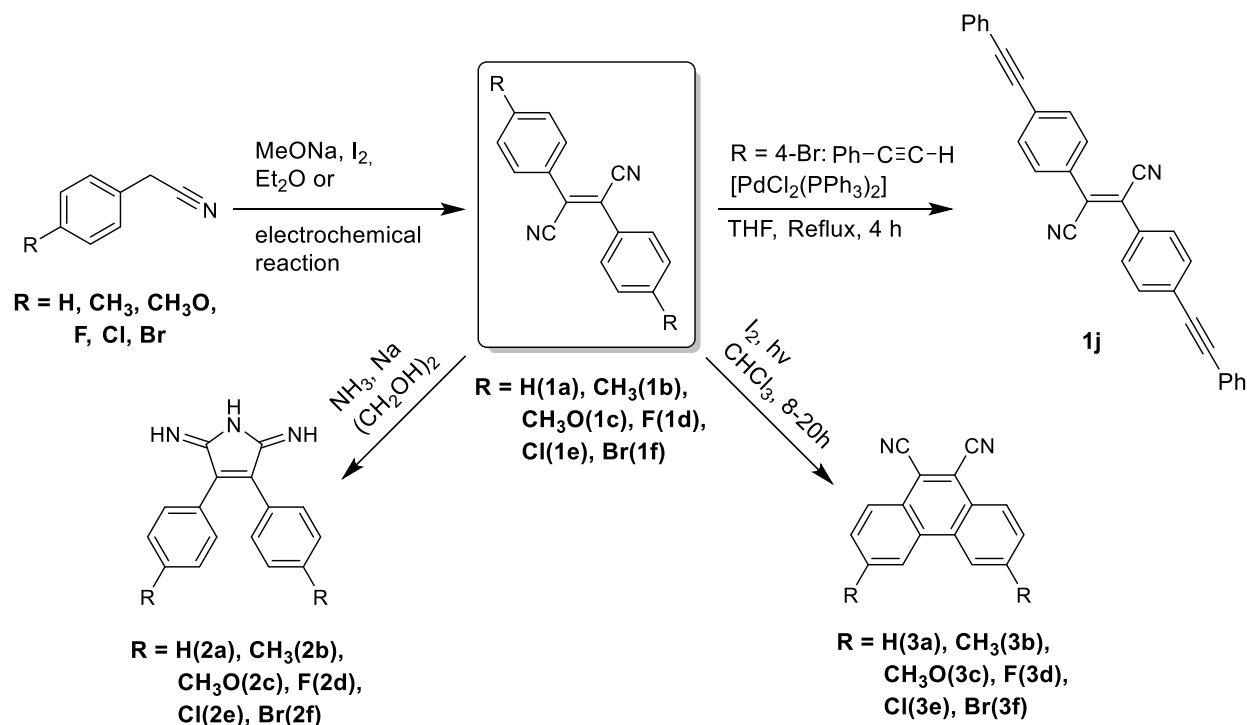
THE INFLUENCE OF SUBSTITUENTS AND AGGREGATION STATE ON THE LUMINESCENCE  
OF 2,3-DIARYLFUMARONITRILES AND THEIR DERIVATIVES

*Taishev A.E., Afanasenko A.M., Chulkova T.G.*

Saint Petersburg State University, Saint Petersburg, Russia  
Student

[artur52520@gmail.com](mailto:artur52520@gmail.com)

Organic materials with efficient luminescence in the solid state have several applications in various research fields, including organic light-emitting diodes (OLEDs), luminescent sensors, bioimaging, surface coatings, inks, etc. The photophysical properties of solids are sensitive to the subtle interplay of the molecular arrangement, therefore, it is difficult to predict or control the solid state luminescence. Compounds may often exhibit a reduced emission in the solid state compared to solution owing to aggregation-caused quenching. Other compounds, on the contrary, show weak luminescence in solution and strong luminescence in the solid state.



**Figure 1.** Reaction of synthesis of 2,3-diarylfumaronitriles (**1**), 3,4-diaryl-1H-pyrrol-2,5-diimines (**2**) and phenanthrene-9,10-dicarbonitriles (**3**)

In this work, we studied the photophysical properties of 2,3-diarylfumaronitriles (**1**), 3,4-diaryl-1H-pyrrol-2,5-diimines (**2**) and phenanthrene-9,10-dicarbonitriles (**3**) with the electron-donor and electron-withdrawing substituents in the solid state and in solution. The position of the maximum of luminescence band and the quantum yield are practically independent on the substituents in the aromatic rings. Also, intermolecular interactions in the solid state control photophysical properties. All compounds are classified as fluorescent phosphors, because the short lifetimes of the excited states (1-30 ns) are observed.

#### References

- [1] Afanasenko A. M. *et al. Journal of Molecular Structure* **2017**, 1146, 554–561.  
[2] Afanasenko A. M. *et al. Journal of Molecular Structure* **2020**, 1199, 126789.

**Acknowledgments.** We thank the Centre for Optical and Laser Materials Research, Centre for Chemical Analysis and Materials Research, Centre of Magnetic Resonance and Research Centre for X-ray Diffraction Studies (all belong to Saint Petersburg State University) for physicochemical measurements.

## BIOLOGIACALLY ACTIVE POLYPHENOLIC COMPOUNDS FROM *LESPEDEZA BICOLOR*

*Tarbeevea D.V.*<sup>1</sup>, *Fedoreyev S.A.*<sup>1</sup>, *Krylova N.V.*<sup>2</sup>, *Iunikhina O.V.*<sup>2</sup>, *Berdyshev D.V.*<sup>1</sup>

<sup>1</sup>G.B. Elyakov Pacific Institute of Bioorganic Chemistry, Far-Eastern Branch of the Russian Academy of Sciences, Vladivostok, Russia

<sup>2</sup>G.P. Somov Institute of Epidemiology and Microbiology, Far-Eastern Branch of the Russian Academy of Sciences, Vladivostok, Russia  
Young scientist  
[tarbeevea1988@mail.ru](mailto:tarbeevea1988@mail.ru)

*Lespedeza bicolor* Turcz. is a shrub plant belonging to the Leguminosae family. It is widely distributed in East Asia, including the Primorye region of the Russian Far East. *L. bicolor* contains flavonoids, isoflavonoids and other plant polyphenolic compounds. The special feature of this plant is its ability to biosynthesize prenylated and geranylated polyphenolic compounds. These compounds have phenolic hydroxyl groups and lipophilic prenyl or geranyl side chains in their structures, which probably results in a considerable antibacterial, antifungal, antitumor, antimetastatic, antioxidant, antidiabetic and antiaggregant activity of *L. bicolor* extracts.

Six new pterocarpans (6a*R*,11a*R*)-6a,11a-dihydrolespedezol A<sub>2</sub> (**2**), (6a*R*,11a*R*)-2-isoprenyl-6a,11a-dihydrolespedezol A<sub>2</sub> (**3**), (6a*R*,11a*R*,3'*R*)-6a,11a-dihydrolespedezol A<sub>3</sub> (**4**), (6a*R*,11a*R*,3'*S*)-6a,11a-dihydrolespedezol A<sub>3</sub> (**5**), (6a*R*,11a*R*)-8-*O*-methyl-6a,11a-dihydrolespedezol A<sub>2</sub> (**6**), two new dimeric flavonoids lespebicolin A (**7**) and lespebicolin B (**8**) consisting of pterocarp and arylbezofuran moieties, and one new stilbenoid with 1,2-diketone fragment named bicoloketone (**9**) along with one previously known pterocarp lespedezol A<sub>2</sub> (**1**) were isolated from *L. bicolor* stem bark using multistage column chromatography on polyamide and silica gel. The structures of the isolated compounds were determined by spectroscopic methods. The absolute configurations of **4** and **5** were determined by comparison of their electronic circular dichroism (ECD) spectra obtained experimentally and the spectra calculated using time-dependent density functional theory (TDDFT). The polyphenolics **1-9** exhibited a moderate DPPH scavenging effect and ferric reducing power compared to the reference antioxidant quercetin. The cytotoxicity of compounds against three human cancer cell lines, HTB-19, Kyse-30, and HEPG-2, and two normal cell lines, RPE-1 and HEK-293, was tested using the MTT assay. All the tested compounds possessed moderate cytotoxic activity *in vitro*, which may be due to the interaction of these compounds with cell membranes and target proteins. Compound **3** having an additional isoprenyl moiety showed the strongest cytotoxic activity among the tested compounds against all cell lines (IC<sub>50</sub> 6.0–19.1 μM).

Besides, these compounds selectively inhibited human drug-resistant prostate cancer cells *in vitro*. Prenylated pterocarpans **1-3** prevented the cell cycle progression of human cancer cells in S-phase. This was accompanied by a reduced expression of mRNA corresponding to several human cyclin-dependent kinases (CDKs). In contrast, compounds **4-7** and **9** induced a G1-phase cell cycle arrest without any pronounced effect on CDKs mRNA expression. Interestingly, a non-substituted hydroxy group at C-8 of ring D of the pterocarp skeleton of compounds **1-3** seems to be important for the CDKs inhibitory activity.

Here we also investigated for the first time the ability of prenylated polyphenolic compounds from *L. bicolor* to inhibit HSV-1 replication in Vero cells. The inhibitory effects of tested compounds on different stages of the HSV-1 infection were assessed by following treatment scheme: compounds were added directly to the virus suspension (pretreatment of virus - virucidal activity); at the same time with infection (simultaneous treatment), or 1 h after infection (post-infection treatment) using a plaque reduction assay. The antiviral effect of tested compounds was compared to that of the untreated virus after 72 h incubation and the obtained results were used for calculations of the concentration causing a 50% reduction in plaque formation (IC<sub>50</sub>) and the selectivity index (SI) as the ratio of CC<sub>50</sub> to IC<sub>50</sub> for each of the compounds. Among the tested compounds (6a*R*,11a*R*)-2-isoprenyl-6a,11a-dihydrolespedezol A<sub>2</sub> (**3**) showed moderate cytotoxicity against Vero cells. This pterocarp possessed significant virucidal activity with the lowest IC<sub>50</sub> and the highest SI values (2.6 μM and 27.9, respectively) and had moderate effect under simultaneous treatment of Vero cells with compound and virus (IC<sub>50</sub> and SI values were 5.86 μM and 12.4, respectively).

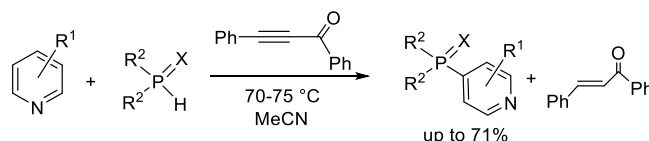
Thus, prenylated polyphenolic compounds have a versatile spectrum of biological activities and are perspective antitumor and antiviral agents.

# THE UNEXPECTED 2,4-MIGRATION IN $S_N^H$ REACTION OF PYRIDINES WITH PHOSPHINE OXIDES STIMULATED BY ELECTRON-DEFICIENT ACETYLENES

*Telezhkin A.A., Volkov P.A., Khrapova K.O.*

A.E. Favorsky Irkutsk Institute of Chemistry, Siberian Branch of the Russian Academy of Sciences, Irkutsk, Russia  
Young scientist  
[telezhkin@irioch.irk.ru](mailto:telezhkin@irioch.irk.ru)

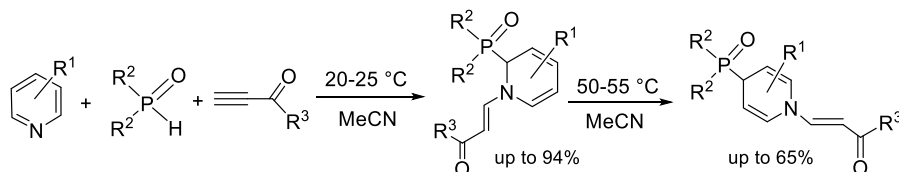
Recently, we have developed a new type of nucleophilic substitution of hydrogen ( $S_N^H$  reaction) in non-activated pyridines by phosphine chalcogenides in the presence of internal acylacetylenes accompanied by elimination of the *E*-chalcones [1] (Figure 1). The process has wide substrate scope both for various secondary phosphine chalcogenides and for various pyridines.



**Figure 1.**  $S_N^H$  cross-coupling of pyridines with phosphine chalcogenides.

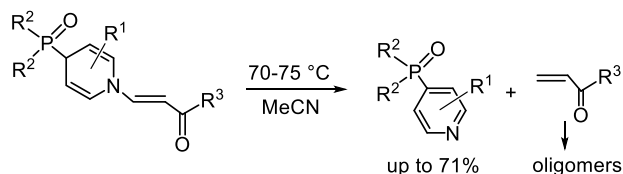
To further develop the synthetic potential of the discovered  $S_N^H$  reaction, new representatives of electron-deficient acetylenes, terminal acylacetylenes, have been introduced into this process. Surprisingly, the reaction took entirely another way. It proceeded at room temperature with the unexpected 1,2-addition of secondary phosphine oxide to the pyridine ring to stereoselectively give 1-*E*-acylvinyl-2-diphenylphosphoryl-1,2-dihydropyridines (Figure 2).

The synthesized 1,2-dihydropyridines undergo 2,4-migration of phosphoryl groups at 50–55 °C to deliver the corresponding 4-phosphoryl-1,4-dihydropyridines (Figure 2).



**Figure 2.** Phosphorylation of pyridines with phosphine oxides in the presence of terminal acylacetylenes.

The heating of 1,4-dihydropyridines at 70–75 °C leads to redox elimination of acylvinylketones to give 4-phosphorylpyridines, the target products of the  $S_N^H$  reaction (Figure 3). Acylvinylketones undergo oligomerization under these conditions.



**Figure 3.** Aromatization of the intermediate dihydropyridines.

Thus,  $S_N^H$  reaction of pyridines with phosphine oxides stimulated by electron-deficient acetylenes proceeds *via* 2,4-migration of phosphoryl groups in the intermediate 1-acylvinyl-2-phosphoryl dihydropyridines with simultaneous redox elimination of the vinyl ketone oligomers. The synthesized phosphorylpyridines are promising ligands for the design of metal complexes, precursors of biologically active drugs, and building blocks for organoelement synthesis.

## References

[1] Trofimov B.A., Volkov P.A., Khrapova K.O., Telezhkin A.A., Ivanova N.I., Albanov A.I., Gusarova N.K., Chupakhin O.N. *Chem. Commun.* **2018**, *54*, 3371–3374

Acknowledgements. This work was supported by the Russian Science Foundation (Project No 18-73-10080).

## MECHANISTIC FEATURES IN FORMATION OF FUROXANYL IMINES

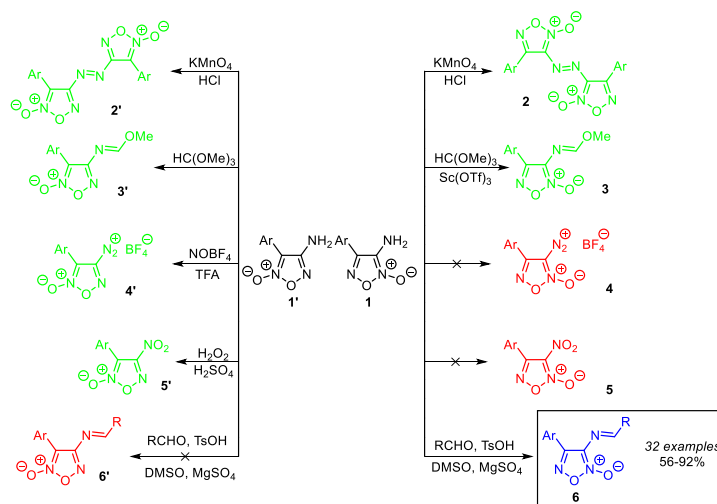
*Teslenko F.E.<sup>1</sup>, Larin A.A.<sup>1</sup>, Malyshev V.I.<sup>1</sup>, Medvedev M.G.<sup>1</sup>, Fershtat L.L.<sup>1</sup>, Makhova N.N.<sup>1</sup>*

<sup>1</sup> Zelinsky Institute of Organic Chemistry Russian Academy of Sciences, Moscow, Russia

Student

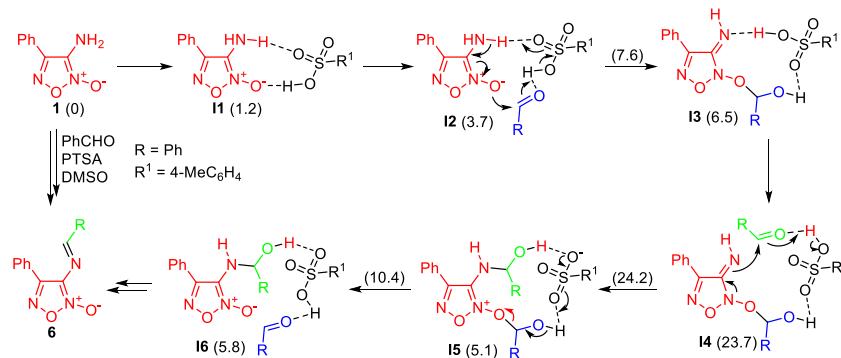
[fete01@mail.ru](mailto:fete01@mail.ru)

*N*-oxide motif of the 1,2,5-oxadiazole-2-oxide (so-called furoxan) scaffold is the reason of asymmetry of the ring which enables a formation of two regioisomers with different reactivity. Experimental data show that 4-aminofuroxan **1'** is more reactive than 3-isomer **1** [1]. Despite the structural similarity the only same reaction for them is the oxidation to azocompounds **2** and **2'** (figure 1). Imino ethers were synthesized for both series of isomeric aminofuroxans. However, it is impossible to oxidize 3-aminofuroxans to 3-nitrofuroxans **5** and to synthesize diazonium salts **4**. Due to the strong electron withdrawing effect of the furoxan ring, reactions of aminofuroxans with carbonyl compounds were unknown so far. Surprisingly, it was found, that «unreactive» 3-amino isomer produced target imine in mild conditions, unlike the active 4-amino isomer, which was demonstrated on a wide substrate scope of thus prepared imines.



**Figure 1.** Comparison of reactivity of isomeric aminofuroxans.

To explain this paradox, we performed quantum chemical calculations at PBE0-D3BJ/def2-SVP/PCM(DMSO) level of theory in Gaussian09 program package. According to the calculations, the reaction has a third order. To proof this theory, kinetic experiment using <sup>19</sup>F NMR was conducted. The value of reaction constant was independent from time for third order reaction, so we can consider that quantum chemical calculations predicted true mechanism (figure 2). Also, reaction time was about 10-24 h for different substrates which correlates with the highest value of energy (24.2 kcal/mol).



**Figure 2.** Calculated free energies of intermediates and transition states (in kcal/mol) and plausible mechanism.

### References

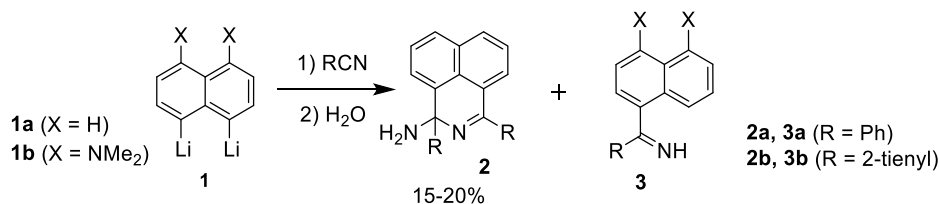
[1] Bystrov, D.M., Fershtat, L.L.; Makhova, N.N. *Chem. Heterocycl. Compd.* **2019**, *55*, 1143–1164

PERI-DILITHIONAPHTHALENES IN THE SYNTHESIS OF 4H-BENZO[DE]ISOQUINOLINES

*Tolochenko D.O., Antonov A.S.*

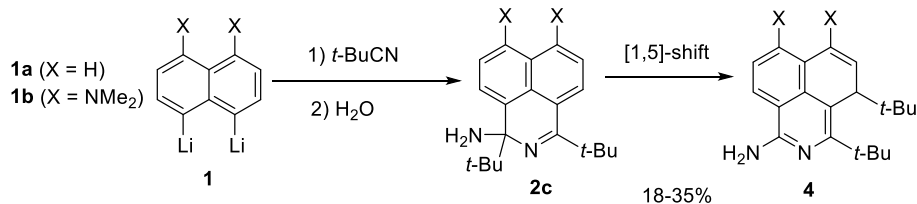
Saint Petersburg State University, Saint Petersburg, Russia  
 Student  
 st085862@student.spbu.ru

We have demonstrated that the interaction between 1,8-dilithionaphthalene **1a** and arylcyanides surprisingly leads to the formation of benzo[de]isoquinolines **2a,b** together with small admixture of monoimines **3a,b**. At the same time the treatment of 4,5-dilithio-1,8-bis(dimethylamino)naphthalene **1b** with the same arylcyanides leads to the formation of monoimines **3** exclusively (Scheme 1). We believe that the formation of monoimines originates from high basicity of dilithionaphthalene facilitating deprotonation of C-H bonds of used arylcyanides instead of nucleophilic attack to cyano group. This unfortunate outcome becomes the major result of the reaction in the case of extremely basic **1b**.



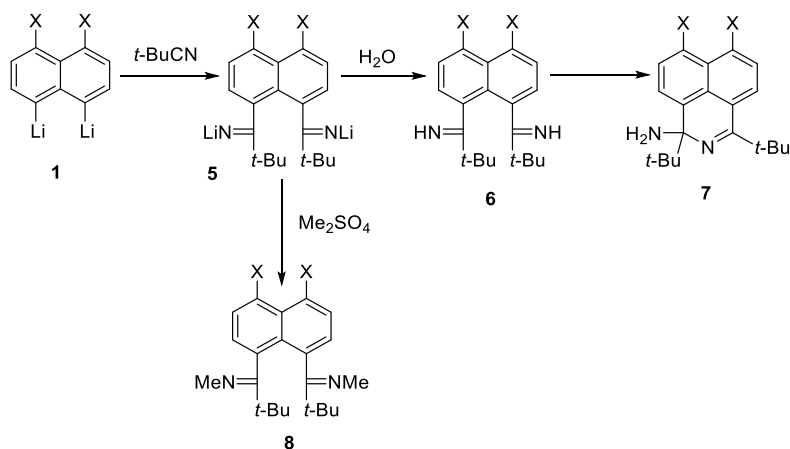
Scheme 1.

Transition to the less acidic *tert*-butylcyanide excludes the formation of monoimines. However instead of the **2c** the isomeric **4** were formed due to [1,5]-sigmatropic shift of *tert*-butyl group (Scheme 2).



Scheme 2.

The most reasonable explanation of this unexpected cyclisation is the proximity of imino groups in the naphthalene core, which sterically facilitates nucleophilic attack. We believe that reaction starts with the formation of *peri*-diimides **5**, which upon hydrolysis to diimines **6** undergo spontaneous intramolecular nucleophilic cyclisation into **7** (Scheme 3). We have demonstrated that treatment of the reaction mixture with dimethylsulfate prior to quenching with water results in the formation of Schiff bases **8** exclusively. Thus, it was proven that the cyclisation occurs only after formation of neutral imines **6**.



Scheme 3.

## AZINE-[*n*]HELICENE HYBRIDS: SYNTHESIS AND PROPERTIES

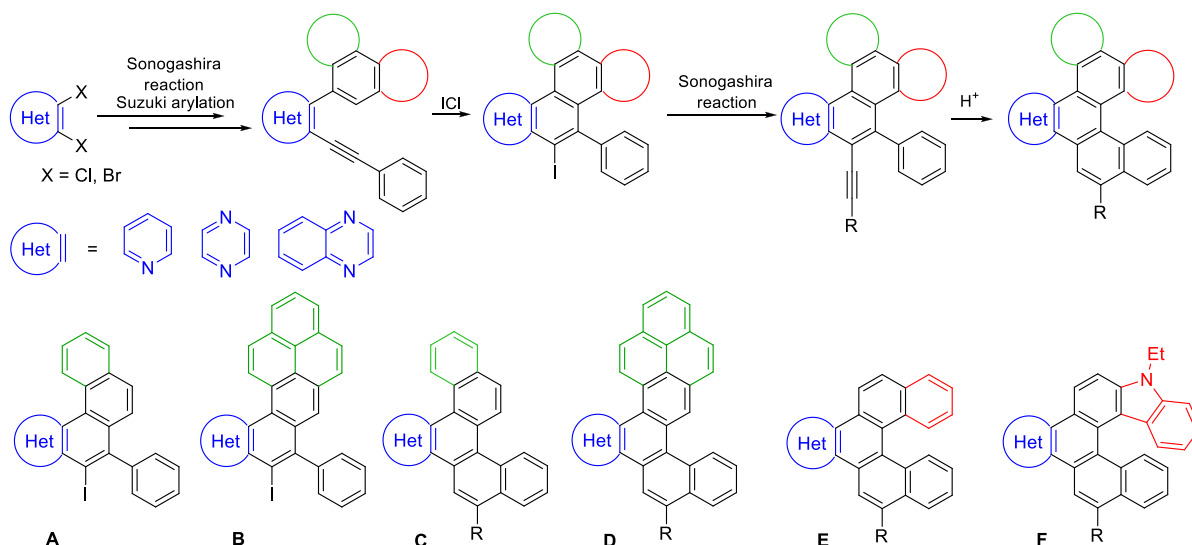
*Tonkoglazova D. I., Gulevskaya A. V.*

Southern Federal University, Rostov-on-Don, Russia  
Ph.D. Student  
[oblipka@mail.ru](mailto:oblipka@mail.ru)

[*n*]Helicenes are *ortho*-fused polycyclic aromatic molecules with nonplanar screw-shaped helical skeletons. The helical topology, together with the extended  $\pi$ -system, gives the helicenes unique chiral, optical, electronic, magnetic, and chelating properties [1]. Numerous examples of the use of helicenes as liquid crystals, nonlinear optical materials, ladder structure polymers, chiral catalysts and ligands, chiral receptors, molecular motors, optoelectronic materials, *etc.* are described.

The helix length increasing is one of the most common structural modifications of these compounds. However, the replacement of one or more carbon atoms in the carbohelicene molecule by heteroatom allows to fine-tune optoelectronic properties as well as to extend the possibilities of the practical application.

Recently, we have developed a general synthetic approach to the synthesis of [4]-, [5]- and [6]helicenes **A-F** containing in their structure or annelated with a heteroring (Figure 1) [2-4]. The synthetic methodology to the azine-[*n*]helicene hybrids includes five steps. The starting compounds are commercially available 2,3-dihalogenazines. Two key steps of the method are electrophile-induced 6-*endo-dig*-cyclizations of *ortho*-alkynylbiaryls. In all cases, the total yield of the helicenes in five stages exceeded 30%.



**Figure 1.** Synthesis of the azine-[*n*]helicene hybrids **A-F**.

To discern the effect of the azine moieties incorporation into the helical skeleton, the molecular structure, crystal packing, and photophysical properties of the synthesized heterohelicenes and the corresponding [*n*]carbohelicenes or non-fused analogs were compared.

### References

- [1] Chen C.-F., Shen Y. *Helicene Chemistry. From Synthesis to Applications*, Springer-Verlag Berlin Heidelberg, Berlin, **2017**, 272
- [2] Gulevskaya A.V., Shvydkova E.A., Tonkoglazova D.I. *Eur. J. Org. Chem.* **2018**, 5030–5043
- [3] Gulevskaya A.V., Tonkoglazova D.I., Guchunov A.S., Misharev A.D. *Eur. J. Org. Chem.* **2019**, 4879–4890
- [4] Tonkoglazova D.I., Gulevskaya A.V., Chistyakov K.A., Askalepova O.I. *Beilstein J. Org. Chem.* **2021**, 17, 11–21

# GOLD(I)-CATALYZED INTRAMOLECULAR ELECTROPHILIC AROMATIC SUBSTITUTION OF ISOXAZOLES

*Tsuda M.*<sup>1,2</sup>, *Morita T.*<sup>2</sup>, *Fukuhara S.*<sup>1,2</sup>, *Nakamura H.*<sup>2</sup>

<sup>1</sup>School of Life Science and Technology, Tokyo Institute of Technology, Yokohama, Japan

<sup>2</sup>Laboratory for Chemistry and Life Science, Tokyo Institute of Technology, Yokohama, Japan

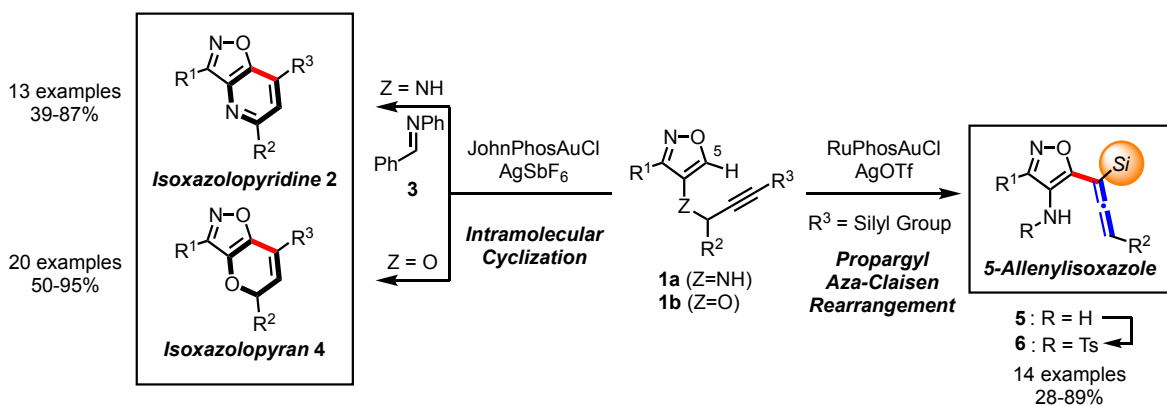
Ph. D. Student

[tsuda.m.ab@m.titech.ac.jp](mailto:tsuda.m.ab@m.titech.ac.jp)

**Introduction:** Isoxazole is one of the most important heteroaromatic compounds that are frequently used as scaffolds of drug candidates. Isoxazole-containing fused heterocyclic systems are also found in biologically active compounds. Although various synthetic approaches for isoxazole-containing fused heterocycles have been developed, heterocycle formation at the 3- or 5-position of isoxazole has rarely been developed. Due to the instability of 3- and/or 5-unsubstituted isoxazoles under mild basic conditions, deprotonation at the 3- or 5-position followed by electrophilic trapping is not applicable for direct functionalization of isoxazoles [1,2]. Furthermore, electrophilic aromatic substitution ( $S_EAr$ ) of isoxazoles is also difficult because of their poor nucleophilicity. In this study, we employed cationic gold(I) catalyst that activates an alkyne moiety as a strong electrophile to induce  $S_EAr$  reaction at the 5-position of isoxazoles.

**Methods and Results:** We first examined the cationic gold(I)-catalyzed  $S_EAr$  reaction of 4-propargylaminoisoxazole **1a** ( $Z = NH$ ) to afford isoxazolopyridines **2** via oxidative cyclization. After screening the additives, *N*-phenylbenzaldimine (**3**) was found to be useful for accelerating the formation of pyridine ring. As a result, we succeeded in the synthesis of isoxazolopyridines **2** in good to high yields. This intramolecular cyclization was extended to 4-propargyloxyisoxazoles **1b** ( $Z = O$ ), and isoxazolopyranes **4** were obtained in good to high yields [3]. Interestingly, we found that 4-propargylaminoisoxazoles **1a** having silyl-substituted alkynes were converted to 5-allenyl-4-aminoisoxazoles **5** through propargyl aza-Claisen rearrangement. Investigations on this reaction revealed that a cationic gold(I) catalyst and silyl group on the alkyne are essential for this transformation. The desired 5-allenyl-4-aminoisoxazoles were isolated after *N*-tosylation, and the structure was unambiguously confirmed by X-ray crystallographic analysis. The reaction mechanism of propargyl aza-Claisen rearrangement has not been proven sufficiently, because the allene intermediates have not been isolated. In other words, this is the first isolation of allene intermediate generated by propargyl aza-Claisen rearrangement [4].

**Conclusions:** We successfully demonstrated the first  $S_EAr$  reaction at the C5-position of isoxazoles using gold(I) catalysts to provide novel bicyclic heterocycles. In addition, isoxazoles having pendant silyl alkynes gave the 5-allenylisoxazoles **6** through propargyl aza-Claisen rearrangement.



**Figure 1.** Overview of our research on Gold(I)-catalyzed intramolecular  $S_EAr$  reaction of isoxazoles.

## References

- [1] T. Morita, S. Fuse, H. Nakamura, *Angew. Chem. Int. Ed.* **2016**, *55*, 13580–13584.
- [2] S. Fukuhara, S. Yugandar, S. Fuse, H. Nakamura, *ACS. Omega.* **2018**, *3*, 16472–16476.
- [3] T. Morita, S. Fukuhara, S. Fuse, H. Nakamura, *Org. Lett.* **2018**, *20*, 433–436.
- [4] M. Tsuda, T. Morita, S. Fukuhara, H. Nakamura, *Org. Biomol. Chem.* **2021**, *19*, 1358–1364.

**Acknowledgements.** This work was partially supported by a Grant-in-Aid for Research Activity Start-up (20K22522) and a Grant-in-Aid for JSPS Fellows (17J02929) from the Japan Society for the Promotion of Science (JSPS).

## PUSH-PULL BUTADIYNES BASED ON THE "PROTON SPONGE"

*Tsybulin S.V., Filatova E.A., Pozharskii A.F.*

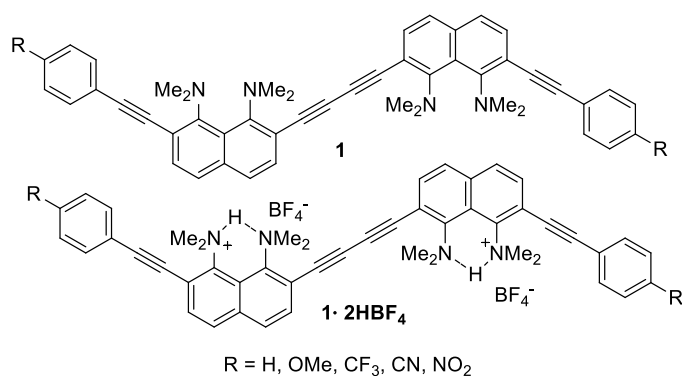
Southern Federal University, Rostov-on-Don, Russia

Ph.D. Student

[tsybulin.sem@yandex.ru](mailto:tsybulin.sem@yandex.ru)

1,3-Diynes are widely used as starting materials in the catalyzed synthesis of carbo- and heterocyclic compounds [1,2]. The unusual photophysical and spectral properties of the diynes make it possible to consider them as promising candidates for the development of active semiconductor materials for transistors and LEDs in electroluminescent devices and organic solar cells. The so-called push-pull butadiynes having electron-donating and electron-withdrawing substituents at the opposite ends of the carbon chain are of considerable interest. In such molecules, intramolecular charge transfer takes place leading to effective polarization along the  $\pi$ -conjugation axis.

In this study, previously unknown symmetric 1,4-diaryl-1,3-butadiynes, in which the butadiyne bridge connects two fragments of 1,8-bis(dimethylamino)naphthalene ("proton sponge"), and their salts were synthesized.



**Figure 1.** 1,4-Diaryl-1,3-butadiynes based on the "proton sponge".

The presence of a substituent in the benzene residue of oligomers **1** allows to vary their structural, photophysical and electrophysical properties. The specificity of the "proton sponge" as a strong and low-nucleophilic base provides additional opportunities for fine tuning of the properties of the diynes through their protonation. Spectral, acid-base and redox studies revealed large differences between salts and bases of the synthesized oligomers. In particular, fully protonated oligomers, unlike bases, have a rigid rod-like structure ("molecular wires") and display fluorescence activity.

### References

- [1] Siemsen P., Livingston R.C., Diederich F., *Angew. Chem. Int. Ed.* **2000**, 39, 2632–2657
- [2] Sindhu K.S., Anilkumar G., *RSC Adv.* **2014**, 4, 27867–27887

Acknowledgements. This work was supported by Russian Foundation for Basic Research (project No 20-33-90017).



APPLYING THE SHAPE SELECTIVITY APPROACH TO REGULATE SELECTIVITY  
PRINS REACTIONS WITH 2-METHYLPROPENE

*Tukhvatshin V.S.<sup>1</sup>, Talipov R.F.<sup>1</sup>*

<sup>1</sup>Bashkir State University, Ufa, Russia  
Assistant professor  
[vadimtukhvatshin@yandex.ru](mailto:vadimtukhvatshin@yandex.ru)

The main industrial method for producing isoprene-monomer today is a two-stage method, including the catalytic decomposition of 4,4-dimethyl-1,3-dioxane (DMD). The latter, in turn, is formed by condensation of 2-methylpropene and aqueous formaldehyde according to Prince under the conditions of acid catalysis [1].

At the same time, this method of isoprene synthesis has a significant drawback: at the first stage, along with DMD, the formation of by-products - hydrogenated pyrans (up to 30 wt%) is observed.

Earlier, a theoretical approach was proposed for the possibility of increasing the selectivity of formation of 1,3-dioxanes according to Prince, based on a combination of two main complementary factors: the formation of 1,3-dioxanes by intramolecular stabilization of the carbocation with the participation of formaldehyde oligomers (cyclic transition state) and the possibility of using the shape selectivity approach.

For this reason, in this work, we studied the effect of the pore diameter of ceramic (synthetic zeolites) and carbon-containing (glassy carbon and nanotubes) porous materials on the selectivity of DMD formation in the interaction of 2-methylpropene and formaldehyde.

The reaction was carried out in the presence of 5% wt. phosphoric acid and 5% wt. porous material at 75°C. Formaldehyde consumption was determined by titration, and DMD accumulation was determined by chromatographic method (internal standard was 4,4,5-trimethyldioxane-1,3).

**Table** Values of the rate constants for the consumption of formaldehyde and the accumulation of DMD

	d, Å	Reaction rate constant of accumulation of DMD, $k \times 10^{-4} \text{ s}^{-1}$	Reaction rate constant for CH <sub>2</sub> O consumption, $k \times 10^{-4} \text{ s}^{-1}$	The ratio of DMD to hydrogenated pyrans (mol)
H <sub>3</sub> PO <sub>4</sub>	0	1,50±0,08	0,46±0,03	4/1
KA	3	5,80±0,34	0,91±0,05	5/1
NaA	4	8,20±0,39	1,30±0,07	-
CaA	5	9,21±0,42	1,50±0,08	-
CaX	8	7,50±0,52	0,93±0,05	1,5/1
NaX	9	1,83±0,08	0,83±0,04	1/1
Carbon nanotubes	7-11	7,50±0,48	0,72±0,04	-
Glassy carbon		13,20±0,79	1,20±0,09	-

It is shown that a change in the pore size of synthetic zeolites dramatically changes the rate of consumption of formaldehyde in the reaction with 2-methylpropene and the accumulation of DMD. The highest rate of formaldehyde consumption and DMD formation is observed when using acid-resistant NaA zeolite. It was found that the highest rate of formaldehyde consumption and DMD accumulation in the reaction with 2-methylpropene is observed when glassy carbon is used.

#### References

- [1] Plate N.A., Slivinsky E.V. *Fundamentals of Chemistry and Technology of Monomers* **2002**. 696  
[2] B. Smit, L. M. Theo, *Nature*, **2008**, 451, 671-678.  
[3] Vakulin I.V., Talipov R.F. *Computational and Theoretical Chemistry*. **2013**, 1013, 57-61

# THE INFLUENCE OF THE OZONE ON THE STRUCTURE AND PROPERTIES OF MEDICAL NONWOVENS BASED ON POLY-3-HYDROXYBUTYRATE

*Tyubaeva P.M.*<sup>1,2</sup>, *Olhov A.A.*<sup>1,2</sup>, *Podmsteriev V.V.*<sup>1</sup>, *Popov A.A.*<sup>1,2</sup>

<sup>1</sup>Emanuel Institute of Biochemical Physics, Russian Academy of Sciences, Moscow, Russia

<sup>2</sup>Plekhanov Russian University of Economics, Moscow, Russia

Student

[polina-tyubaeva@uandex.ru](mailto:polina-tyubaeva@uandex.ru)

Currently, the development of nonwoven fibrous materials for medical purpose with a highly developed surface based on biopolymers is an area of a great interest. The electrospinning of ultrathin fibers from polymer solutions is one of the most effective methods to obtain the highly developed surfaces [1]. An important scientific question is the choice of methods for sterilization and disinfection of these materials with the biomedical purpose [2], which can guarantee the penetration of the sterilizing agent into the structure and sterilization in the whole volume of fibers in a short period of time.

The aim of the work was to considerate the effects of the ozone as the sterilizing agent on the structure and properties of ultrathin poly-3-hydroxybutyrate (PHB) fibers in the material layer. In the work, the kinetic studies of the effect of ozone on the structure and properties of medical nonwovens were carried out and the limits of effective use of ozone for sterilization were established. Figure 1 shows ultrathin fibers obtained in this work with average diameters between 2-5  $\mu\text{m}$ .



**Figure 1.** Reaction.

For the first time, a significant improvement in physical and mechanical properties was found at the initial stage of ozonation of nonwoven material based on PHB: an increase in the breaking load and elastic modulus by 2 times and an increase in the relative elongation by 1.5 times. The reasons for the observed effect are proposed, consisting in the rupture of macromolecules in the amorphous phase followed by more regular laying of macrocycles. The paper describes in detail the processes occurring in the material during the first minutes of exposure to ozone on PHB macromolecules, and also analyzes the parameters that are most sensitive to changes in the supramolecular structure: the degree of crystallinity, the melting temperature, the correlation time of the spin probe in the amorphous phase, the shape of the melting peak, which suggests the nature of PHB oxidation by ozone.

## References

[1] Filatov U.N. *Electrospinning of Fibrous Materials* **1997**

[3] Shtilman M.I. *Technology for obtaining polymers for medical and biological purposes* **2006**

Acknowledgements. The study was carried out using scientific equipment of the Center of Shared Usage «New Materials and Technologies» of Emanuel Institute of Biochemical Physics and the Common Use Centre of Plekhanov Russian University of Economics.

# HELICAL AGGREGATES OF BIS(STYRYL) DYES FORMED BY DNA TEMPLATING

*Ustimova M.A.*<sup>1</sup>, *Fedorov Yu.V.*<sup>1</sup>, *Tsvetkov V.I.B.*<sup>2</sup>, *Fedorova O.A.*<sup>1</sup>

<sup>1</sup>A.N. Nesmeyanov Institute of Organoelement Compounds of Russian Academy of Sciences,  
Moscow, Russia

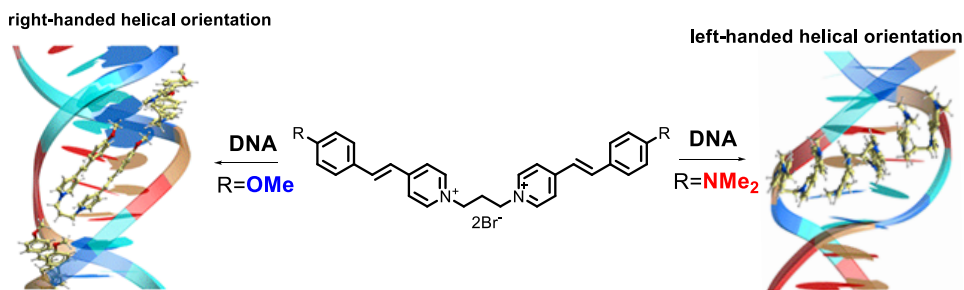
<sup>2</sup>First Moscow State Medical University, Moscow, Russia

Phd Student

ustimova.maria@yandex.ru

The spontaneous noncovalent assembly of cyanine dyes within the minor groove of ds DNA causes the formation of helical dye aggregates in the DNA template which differ in the size and shape [1–3]. The formed well-defined aggregates exhibit induced chirality and interesting optical properties.

In this study, we investigated the effect of substituents in bis(styryl) pyridine dyes on the formation of aggregates in DNA template and fluorescent response on binding with DNA. In the composition of dyes the substituents in the phenyl ring were OMe or/and NMe<sub>2</sub> groups.



**Figure 1.** Right- and left-handed helical assembly of the bis(styryl)pyridinium dyes.

The investigation of mechanism of the bis(styryl) dye – ct-DNA (calf thymus) interaction has been done applying of three different bis(styryl)pyridinium dyes (one of them is asymmetrical and two are symmetrical) possessing OMe or/and NMe<sub>2</sub> substituents in phenyl ring by using of UV–vis and fluorescence spectroscopic techniques, circular dichroism (CD), Hoechst 33258 displacement experiments and quantum-chemical calculations. In case of bis(styryl) dye containing OMe substituent in phenyl ring, the obtained results indicate the formation of aggregates of right-handed chirality (Fig.1). For bis(styryl) dye the left-handed helical assembly of the aggregating chromophores was revealed (Fig.1). Asymmetrical dye composed from OMe- and NMe<sub>2</sub>-containing chromophores is able to form the aggregates in less extend if compare symmetric dyes. In free and bound with DNA asymmetric dye the effective resonance energy transfer was proved between OMe- and NMe<sub>2</sub>-containing chromophores. Such chromophoric pair provides the system with large Stoke's shift. It absorbs at 408 nm and emits at 615 nm. The study of bis(styryl) dye-DNA interaction reveals what structural fragments in composition of dye provides the desirable mode of complex, the investigation could be very important for designing an improved imaging and therapeutic agents.

## References

- [1] Pawlik A., Kirstein S., De Rossi U., Daehne S., *J. Phys. Chem. B* **1997**, *101*, 5646–5651.
- [2] Kurutos A., Ryzhova et al. *Dyes Pigm* **2016**, *130*, 122–128.
- [3] Hilal H., Taylor J.A., *J. Biochem. Biophys. Methods* **2008**, *70*, 1104–1108.

Acknowledgements. This work was supported Russian Foundation for Basic Research (№ 19-03-00535).

# INTRODUCTION OF PHOSPHONIUM GROUPS INTO THE MOLECULES OF BETULIN 3,28-BISESTERS

*Vakhrusheva E.D., Cherdakova E.A., Shafeeva M.V., Aleksandrova E.A., Trishin Yu.G.*

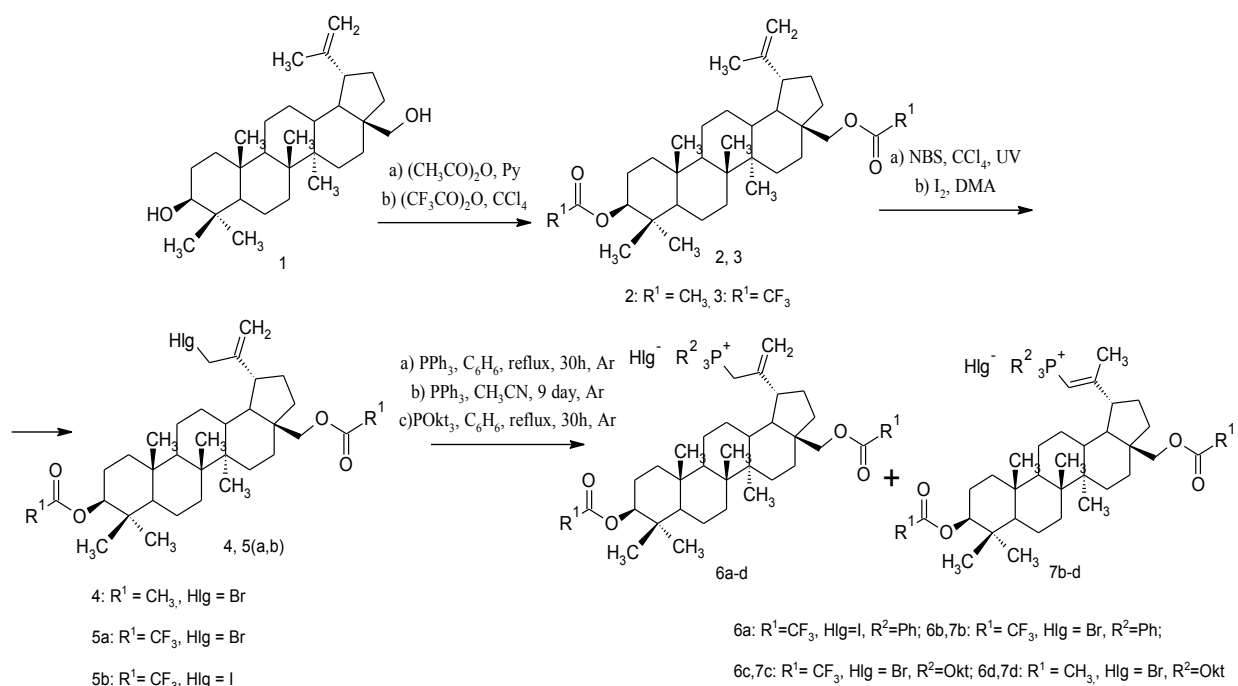
Saint Petersburg State University of Industrial Technologies and Design,  
Higher School of Technology and Energy, Saint Petersburg, Russia  
Student

[vakhrusheva\\_h@mail.ru](mailto:vakhrusheva_h@mail.ru)

Betulin and its derivatives have a wide range of valuable pharmacological properties such as: anti-inflammatory, antiviral, immunomodulatory, antiseptic, antitumor, etc. [1]. The introduction of functional groups into the betulin molecule in many cases expands the spectrum and enhances its effect on the living organism.

In this study, phosphonium halide groups were introduced into the betulin molecule on the 30-C atom. It is known that substances containing phosphonium ions are lipophilic and can easily pass through the phospholipid bilayers of membranes. Triphenylphosphonium cations ensure the delivery of vitamin E [2], lipoic acid [3], and plastoquinone [4] to the mitochondria. Therefore, the preparation of phosphonium-containing betulin derivatives is a constructive approach in the search for new medicinal substances.

We used triphenyl- and trioctylphosphines as phosphorous containing reagents. As the result of the interaction of betulin **1** with acetic and trifluoroacetic anhydrides betulin 3,28-bisesters **2**, **3** were obtained accordingly. Then, bromine and iodine atoms were introduced on position 30. 30-halides of betulin 3,28-bisesters **4**, **5a-b** as a result of treatment with triphenyl- and trioctylphosphines lead to the production of target phosphonium compounds **6a-d**. It was found that when the reaction mixture is boiled, the isomerized phosphonium halide **7b-d** is formed along with the main product of the reaction **6b-d**.



**Figure 1.** Scheme of synthesis of 30-phosphonium halides of betulin 3,28-bisesters

## References

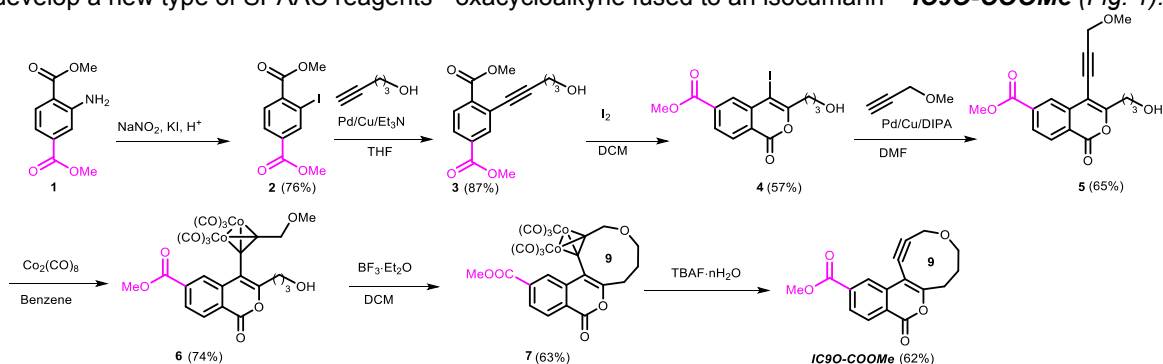
- [1] Tolstikov G.A., Flekhter O.B., Shultz E.E. *Chem. for Sustainable Development* **2005**, 13, 1–29
- [2] Smith R.A., Porteous C.M., Coulter C.V., Murphy M.P. *European J. of Biochemistry* **1999**, 263, 709-716
- [3] Brown S.E., *Free Radical Biology and Medicine* **2007**, 42, 1766–1780
- [4] Skulachev V.P., Anisimov V.N., Antonenko Yu.N., Bakeeva L.E., Chernyak B.V., Elichev V.P., Filenko O.F., Kalinina N.I., Kapelko V.I., Kolosova N.G., Bor *Biochimica et Biophysica Acta (BBA)-Bioenergetics* **2009**, 1787, 437–461

Vidiakina A.A.<sup>1</sup>, Danilkina N.A.<sup>1</sup><sup>1</sup>Saint Petersburg State University, Saint Petersburg, Russia  
Student

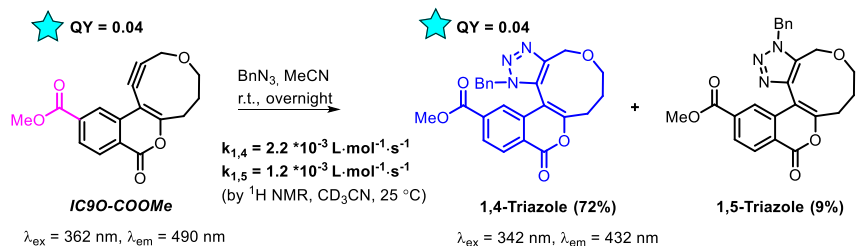
vidyakina.aleksandra@mail.ru

Cycloalkynes are a class of strained organic molecules, which undergo cycloaddition with azides quickly under physiological environment. This reaction is known as Strain-Promoted Alkyne-Azide Cycloaddition (SPAAC) [1] and it has been widely used for bioconjugation in living cells and animals. Therefore, the development of new SPAAC reagents with the optimal stability / reactivity balance is of crucial importance. [2,3]

Nowadays there are two general strategies to improve the kinetics of SPAAC without the loss of cycloalkynes stability and synthetic accessibility: the destabilization of a cycloalkyne reagent by applying an extra strain through the annulation with additional rings [4] and the stabilization of the cycloalkyne – azide interaction transition state (TS) and by stereoelectronic effects. [5] Here we were aimed to apply both strategies to develop a new type of SPAAC reagents - oxacycloalkyne fused to an isocoumarin – **IC90-COOMe** (Fig. 1).

Figure 1. Synthetic scheme of target structure **IC90-COOMe**

The reaction of **IC90-COOMe** with benzyl azide proceeded in good yield (Fig. 2). The SPAAC kinetics of **IC90-COOMe** was found to be fast enough for its further use as a SPAAC reagent in cells.

Figure 2. SPAAC reaction of **IC90-COOMe**

In order to be suitable for bioimaging in cells, either a cycloalkyne should be cross-linked with a dye or corresponding triazoles must possess their own fluorescence. [2] Modification of a cycloalkyne core with a dye requires additional synthetic steps and sometimes could induce some problems with a cell penetration. We noticed that both **IC90-COOMe** and the resulting 1,4-triazole exhibit fluorescent properties upon 365 nm excitation. The quantum yields for **IC90-COOMe** and triazole in aqueous solutions in the presence of 1% DMSO were found to be 4%, which indicates that **IC90-COOMe** reagent could be used for the cells visualization without any additional modifications.

The studies of cells visualization using SPAAC between **IC90-COOMe** and metabolically labeled cells with azidomannose are ongoing.

### References

- [1] Agard, N. J.; Prescher, J. A.; Bertozzi, C. R. *J. Am. Chem. Soc.* **2004**, *126*, 15046; (2) Dommerholt, J.; Rutjes, F.P. J. T.; Delft, F. L. *Top. Curr. Chem.* **2016**, *374*, 16; (3) Harris, T.; Alabugin, I. V. *Mendeleev Commun.* **2019**, *29*, 237–248; (4) Ning, X.; Wolfert, M.A.; Boons, G.-J. *Angew. Chemie Int. Ed.* **2008**, *47*, 2253; [5] Gold, B.; Shevchenko, N.E.; Bonus, N.; Dudley, G. B.; Alabugin, I.V. *J. Org. Chem.* **2012**, *77*, 75

Acknowledgements. This work was supported by the Russian Foundation for Basic Research (project No 20-03-00117).

## SYNTHESIS OF STABLE CRIEGEE INTERMEDIATES

Vil' V.A.<sup>1</sup>, Barsegyan Ya.A.<sup>1</sup>, Semenov E.A.<sup>1,2</sup>, Kuhn L.<sup>3</sup>, Alabugin I.V.<sup>3</sup>, Terent'ev A.O.<sup>1,2</sup>

<sup>1</sup>N.D. Zelinsky Institute of Organic Chemistry RAS, Moscow, Russia

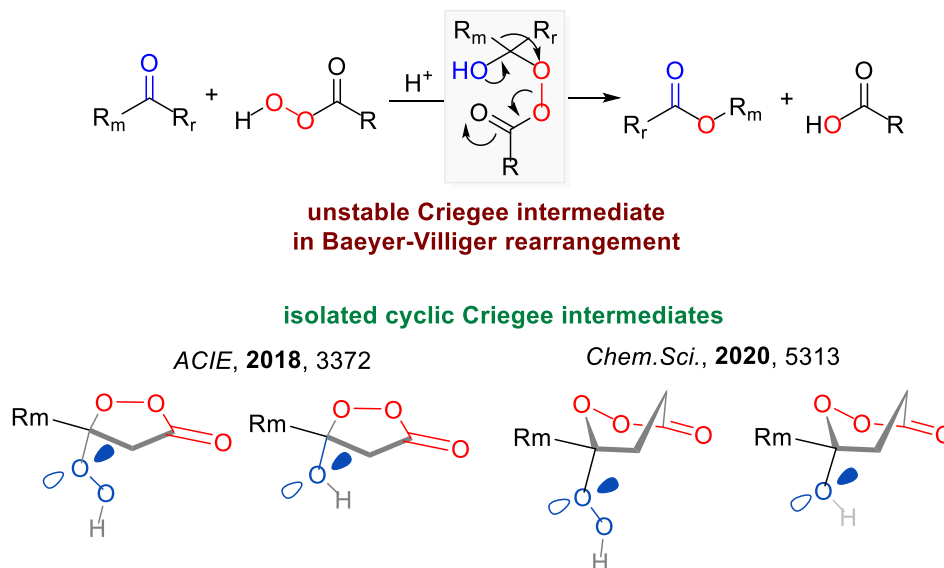
<sup>2</sup>D.I. Mendeleev University of Chemical Technology of Russia, Moscow, Russia

<sup>3</sup>Florida State University, Tallahassee, USA

Researcher, PhD

[vil@ioc.ac.ru](mailto:vil@ioc.ac.ru)

The Baeyer-Villiger (BV) reaction was discovered by Adolf von Baeyer and Victor Villiger in 1899 [1-2]. This oxidative transformation opens synthetic access to an ester from a ketone or to a lactone from a cyclic ketone, using peroxyacids as the oxidant. The hydroxyl peroxyesters, Criegee intermediates of the BV rearrangement, remained elusive due to their high reactivity (Scheme 1) [3]. However, the key to understanding the BV rearrangement mechanism and to the design a stereo- and regioselective BV processes lies in the intimate details of the CI structure, a notion that provides motivation for this research.



**Scheme 1.** Unstable and stable Criegee intermediates of Bayer-Villiger reaction.

The instability of hydroxyl peroxyesters, the elusive Criegee intermediates of the Baeyer-Villiger rearrangement, can be alleviated by selective deactivation of stereoelectronic effects that promote the 1,2-alkyl shift. Stable cyclic Criegee intermediates constrained within a five- and six-membered ring can be prepared by mild reduction of respective hydroperoxyl peroxyesters (hydroperoxy-peroxylactones) which were formed in high yields in reaction of ketoesters with  $\text{BF}_3 \cdot \text{Et}_2\text{O}/\text{H}_2\text{O}_2$  [4-5].

### References

- [1] Baeyer A., Villiger V. *Ber. Dtsch. Chem. Ges.* **1899**, 32, 3625–3633
- [2] Baeyer A., Villiger V. *Ber. Dtsch. Chem. Ges.* **1900**, 33, 124–126
- [3] Criegee R. *Justus Liebigs Ann. Chem.*, **1948**, 560, 127-135
- [4] Vil' V.A., Gomes G.d.P., Bityukov O.V., Lyssenko K.A., Nikishin G.I., Alabugin I.V., Terent'ev A.O., *Angew. Chem. Int. Ed.* **2018**, 57, 3372–3376
- [5] Vil' V.A., Barsegyan Ya.A., Kuhn L., Ekimova M.V., Semenov E.A., Korlyukov A.A., Terent'ev A.O., Alabugin I.V. *Chem. Sci.* **2020**, 11, 5313-5322

Acknowledgements. This work was supported by the Russian Science Foundation (project No 21-43-04417).

# ELECTROCHEMICAL OXIDATION OF ARYLIODIDES AS EFFECTIVE APPROACH FOR GENERATION OF IODONIUM YLIDES

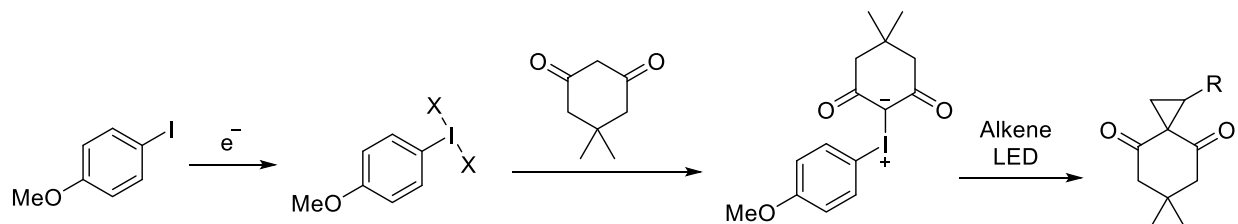
*Vlasenko Y.A.*<sup>1</sup>, *Antonkin N.S.*<sup>1</sup>, *Postnikov P.S.*<sup>1</sup>

<sup>1</sup>National Research Tomsk Polytechnic University, Tomsk, Russia  
PhD student  
[yav6@tpu.ru](mailto:yav6@tpu.ru)

Hypervalent iodine compounds (HIC) are a versatile and effective class of reagents that are widely used in organic synthesis as oxidants [1], atom transfer reagents [1, 2], and, more recently, as organocatalysts due to the formation of halogen bonds [3]. However, the common approaches for the preparation of HIC involve the application of expensive oxidants and the formation of a large number of by-products that are not consistent with modern principles of "green chemistry" [4].

Over the past 10 years, the electrochemical generation of HIC has become an excellent alternative to common methods due to the absence of strong oxidants and dramatic decrease of by-product formation [4]. In addition, it allows using hypervalent iodine compounds as a renewable reagent in catalytic reactions [5]. Despite the active development of the field of HIC generation in the electrochemical mode, such approaches have not been applied to the preparation of iodonium ylides, which are of great interest for organic synthesis and are used in the preparation of heterocyclic compounds, CH modification, cyclopropanation, etc. [6].

We carried out studies on the possibility of the formation of iodonium ylides from the corresponding iodides and diketones under the electrochemical conditions by cyclic voltammetry. In addition, we demonstrated the implementation of suggested procedure for *one-pot* synthesis of cyclopropanes from alkenes and diketones.



**Figure 1.** The synthetic approach to the synthesis of cyclopropanes via electrochemical generation of iodonium ylide

Thus, we carried out voltammetric studies and demonstrated the possibility of an electrochemical generation of iodonium ylides. At the same time, we have proposed a *one-pot* method for the synthesis of cyclopropanes from alkenes and diketones in a combination of photo- and electrochemical activation of organic molecules.

## References

- [1] Yoshimura, A.; Zhdankin, V.V., *Chem. Rev.* **2016**, 116, 3328–3435
- [2] Chen, W.W.; Cuenca, A.B.; Shafir, A., *Angew. Chem. Int. Ed.* **2020**, 59, 16294–16309
- [3] Sutar, R.L.; Huber, S.M., *ACS Catal.* **2019**, 9, 10, 9622–9639
- [4] Martins, G.M.; Shirinfar, B.; Hardwick, T.; Ahmed, N., *ChemElectroChem* **2019**, 6, 1300–1315
- [5] Qian, P.; Zha, Z.; Wang, Z., *ChemElectroChem* **2020**, 7, 2527–2544
- [6] Yusubov, M. S.; Yoshimura, A.; Zhdankin, V. V., *ARKIVOC* **2016**, 1, 342-374

Acknowledgements. This work was supported by the Russian Foundation for Basic Research (project No 20-33-90007).

PSEUDOSANDWICH COMPLEXES OF (18-CROWN-6)STILBENE WITH ALKANEDIAMMONIUM IONS:  
THERMODYNAMIC STABILITY AND PHOTOCHEMISTRY

*Vorozhtsov A.P.*<sup>1</sup>, *Martyanov T.P.*<sup>2,3</sup>, *Aleksandrova N.A.*<sup>3</sup>, *Ushakov E.N.*<sup>2,3</sup>, *Gromov S.P.*<sup>1,3</sup>

<sup>1</sup>Moscow State University, Moscow, Russia

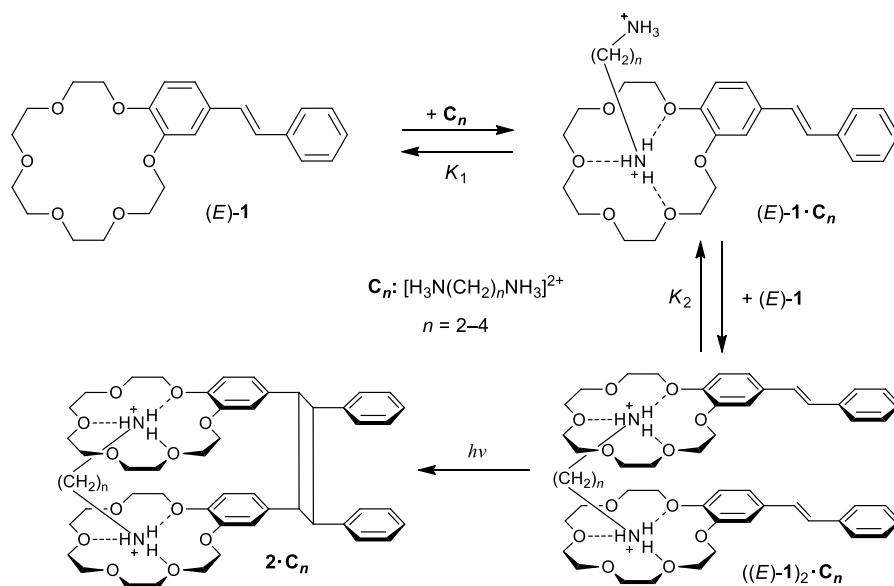
<sup>2</sup>Institute of Problems of Chemical Physics of RAS, Chernogolovka, Russia

<sup>3</sup>The Photochemistry Centre of RAS, FSRC "Crystallography and Photonics", Moscow, Russia  
Student

[artem2001qaz@gmail.com](mailto:artem2001qaz@gmail.com)

The [2+2] photocycloaddition (PCA) reaction of unsaturated compounds is widely used in organic synthesis [1], polymer chemistry and applied physics [2]. However, intermolecular PCA reactions in solution usually have a very low efficiency because of the short lifetime of the electronically excited state and lead to a mixture of cyclobutane stereoisomers. These problems can be solved using supramolecular approaches, which allow one to combine the molecules of unsaturated compounds into pairs with a certain mutual orientation.

In this work, the proximity of the double bonds of two stilbene molecules and their specific orientation were achieved by hydrogen bonding-controlled self-assembly of (18-crown-6)stilbene (*E*)-**1** into sandwich complexes with alkanediammonium ions  $^+H_3N(CH_2)_nNH_3^+$  (**C<sub>n</sub>**),  $n = 2-4$ .



**Figure 1.** The complexation of (18-crown-6)stilbene with diammonioalkanes and subsequent PCA reaction.

It was shown how the length of the diammonium ion affects the stability constants ( $K_1$  and  $K_2$ , Fig. 1) of complexes of different compositions and the quantum yield of the PCA reaction proceeding in pseudosandwich complexes ((*E*)-**1**)<sub>2</sub>·**C<sub>n</sub>**.

#### References

- [1] Bach T., Hehn J. *Angew. Chem. Int. Ed.* **2011**, 50, 1000  
 [2] Wanga Y., Liua Q., Lia J. *Polymer* **2019**, 172, 187

Acknowledgements. This work was supported by the Russian Science Foundation (project No 19-13-00020).



# SWITCHING THE CYCLIZATION OF POLARIZED DIVINYLKETONES: KINETIC, ACID AND STERIC CONTROL

*Yadykov A.V.<sup>1</sup>, Eremchenko A. E.<sup>2</sup>, Sonin I. V.<sup>2</sup>, Shirinian V.Z.<sup>1</sup>*

<sup>1</sup>Zelinsky Institute of Organic Chemistry, 119991 Moscow, Leninsky prosp. 47

<sup>2</sup>Mendeleev university of Chemical Technology of Russia, 125047 Moscow, Miuskaya sq. 9

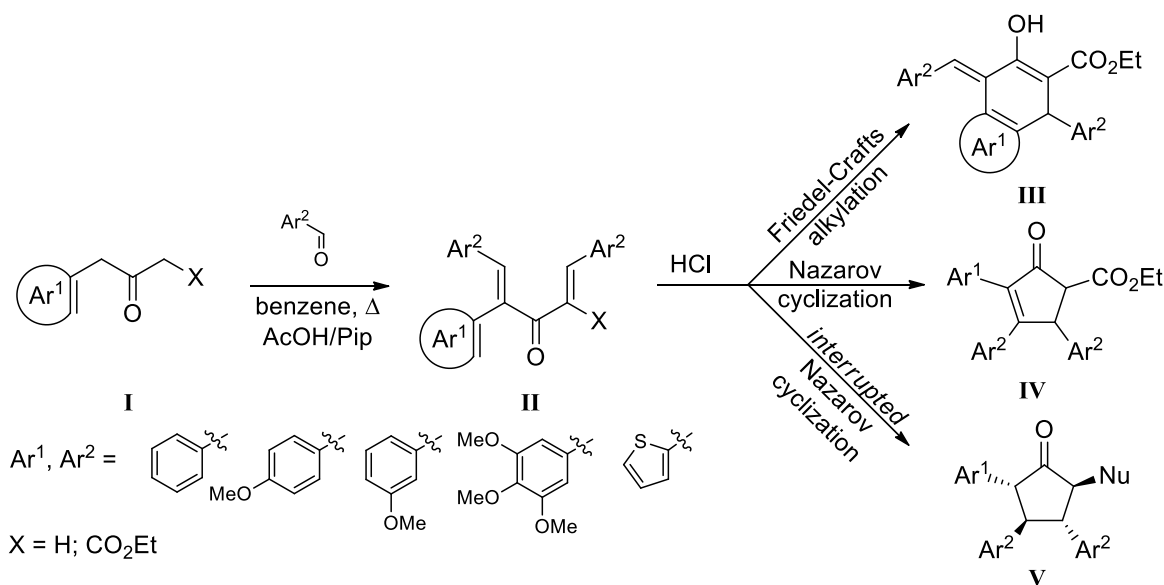
PhD Student

[antonyadykov@gmail.com](mailto:antonyadykov@gmail.com)

Divinyl ketones (DVK) are useful versatile precursor in organic synthesis [1]. The reaction path depending not only on structure of DVK, it also depending on reaction conditions and kind of catalyst [2]. Among of many reactions (like Michael addition, Diels-Alder reaction, etc.) of DVK highlights Nazarov cyclization which leads to substituted cyclopentenones. Besides classical reaction there are many Nazarov type-reactions which are strongly depends on substrate properties.

Recently we investigated a cyclization of polarized triaryl substituted DVK **I** and was found that reaction could leads to cyclopentenons **IV** via Nazarov reaction or to dihydronaphtalenes **III** via intramolecular Friedel-Crafts alkylation depending on  $\alpha$ -substituent to carbonyl group [3,4].

This work we investigate cyclization of polarized and non-polarized DVK **I** catalyzed by Lewis and Brønsted acids. Was found that thien-2-yl  $\alpha$ -substituted polarized DVK undergoes competitive classical Nazarov reaction and intramolecular Friedel-Crafts alkylation depending on steric the nature of  $\beta$ -substitution, moreover, we observed that cyclization of these substrates could be switched by temperature and nature of acid catalyst. On the other hand non-polarized DVK converted to cyclopentanone **V** by nucleophilic attack to oxyallyl cation via "interrupted" Nazarov reaction.



## References

- [1] Frontier A. J., Hernandez J. J. *Acc. Chem. Res.*, **2020**, 53, 1822-1832.
- [2] West F. G., Scadeng O., Wu Y.-K., Fradette R. J., Joy S. *Comprehensive Organic Synthesis II*, **2014**, 5, 827-866
- [3] Shirinian V. Z., Lvov A. G., Yadykov A. V., Yaminova L. V., Kachala V. V., Markosyan A. I., *Org. Lett.* **2016**, 18, 6260-6263
- [4] Yadykov A. V., Yaminova L. V., Krayushkin M. M., Shirinian V. Z. *Adv. Synth. Catal.*, **2021**, 363, 251-258

Acknowledgements. This work was supported by the Russian Science Foundation (project No 18-13-00308П)

## HOW TO COMBINE PEROXIDE AND NITROGEN IN A HETEROCYCLE?

Yaremenko I.A.<sup>1</sup>, Belyakova Yu.Yu.<sup>1</sup>, Radulov P.S.<sup>1</sup>, Medvedev M.G.<sup>1</sup>, Tsogoeva S.B.<sup>2</sup>, Alabugin I.V.<sup>3</sup>,  
Terent'ev A.O.<sup>1</sup>

<sup>1</sup> N. D. Zelinsky Institute of Organic Chemistry, Moscow, Russia

<sup>2</sup> Friedrich-Alexander-Universität Erlangen-Nürnberg, Erlangen, Germany

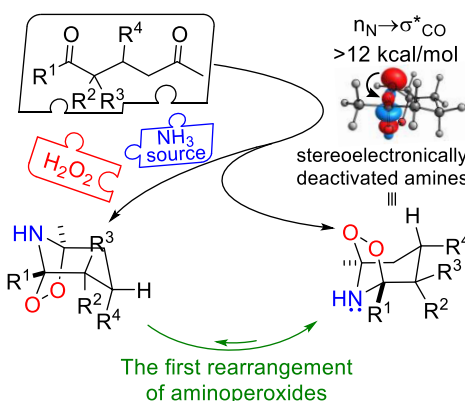
<sup>3</sup> Florida State University, Tallahassee, USA

Senior researcher

[yaremenko@ioc.ac.ru](mailto:yaremenko@ioc.ac.ru)

Organic peroxides offer a largely uncharted chemical space for the development of new medicinal agents with antimalarial, anthelmintic, anticancer, fungicidal, antitubercular, and antiviral activities [1]. Natural peroxide Artemisinin, its derivatives and synthetic analogs such as Artesunate and Arterolan (synthetic ozonide) are important antimalarial drugs. It was found that synthetic ozonides are able to inhibit both the  $\alpha$ -coronavirus NL63,  $\beta$ -coronavirus OC43, and SARS-CoV-2 [2].

The introduction of a nitrogen atom can dramatically expand the choices of possible peroxide-containing functionalities and strongly affect their interaction with biological targets. However, the lack of available synthetic approaches and instability left azaperoxides in the shadow of Artemisinin and other classical peroxides.



**Figure 1.**

In our studies, a general approach to the synthesis of bridged azaperoxides was developed via a catalyst-free three-component condensation of 1,5-diketones with hydrogen peroxide and NH-group source such as aqueous ammonia, ammonium acetate, formate, or carbonate [3]. This approach opens synthetic access to bridged azaozonides with various functional groups such as alkene, alkyne, ester, and cyano. The synthesis is readily scalable and opens practical access to gram quantities of the target azaozonides.

The first peroxide-preserving rearrangement of aminoperoxides in the history of peroxide chemistry was discovered. Transformations of the synthesized azaperoxides were carried out in order to study their stability and to obtain hybrid molecules with antimalarial, anticancer, fungicidal or antiviral activity.

### References

- [1] Vil' V.A., Yaremenko I.A., Ilovaisky A.I., Terent'ev A.O. *Molecules*, **2017**, *22*, 1881
- [2] Ghosh A.K., Miller H., Knox K., Kundu M., Henrickson K.J., Arav-Boger R. *ACS Infect. Dis.* **2021**, 10.1021/acsinfectdis.1c00053
- [3] Yaremenko I.A., Belyakova Yu.Yu., Radulov P.S., Novikov R.A., Medvedev M.G., Krivoshchapov N.V., Korlyukov A.A., Alabugin I.V., Terent'ev A.O. *J. Am. Chem. Soc.* **2021**, *133*, *17*, 6634-6648

Acknowledgements. This work was supported by the Russian Science Foundation (project No 21-43-04417).

# ISOLATION OF STEREOISOMERS OF PHYSIOLOGICALLY ACTIVE COMPOUNDS

Yufryakov V.S.<sup>1</sup>

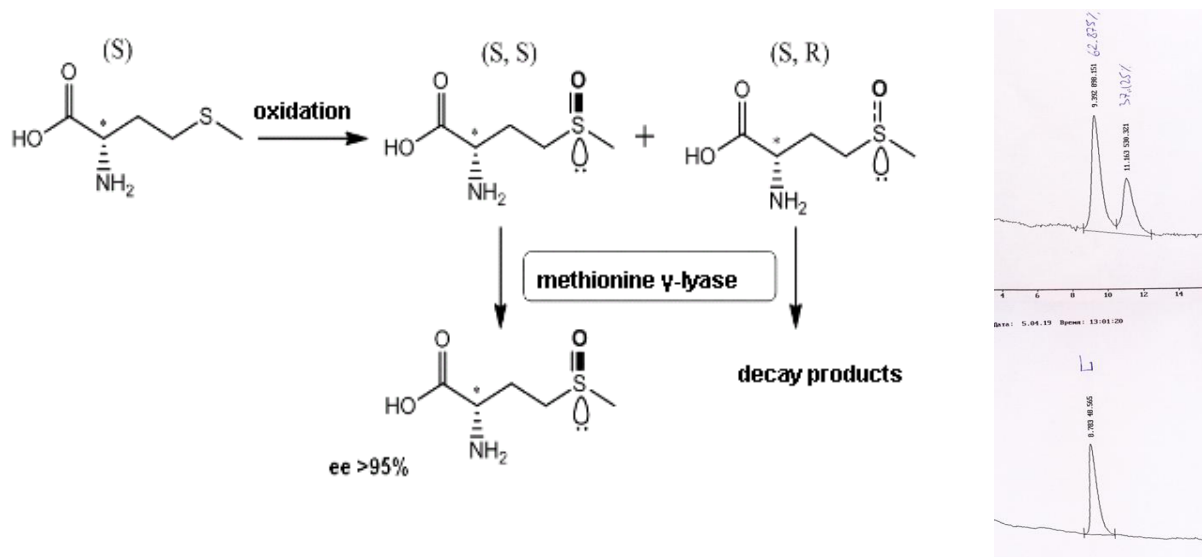
<sup>1</sup>A. N. Nesmeyanov Institute of Organoelement Compounds, Moscow, Russia

PhD student

[rossignol.yufryakov@gmail.com](mailto:rossignol.yufryakov@gmail.com)

The use of physiologically active compounds in pure stereochemically form is an essential requirement for chiral compounds. Among the methods for the cleavage of racemates, the use of chemical-enzymatic approaches is of great importance and, therefore, the search for and study of new substrates is paid great attention all over the world. We have shown the possibility of productive use of enzymes for the kinetic separation of stereoisomers at the key stage in the preparation of biologically active compounds.

Thus, the use of the mutant C115H methionine  $\gamma$ -lyase made it possible to isolate one of the diastereomers of methionine oxide by an approach associated with the difference in their resistance to the enzyme [1]. It has been shown that, under certain conditions, the enzyme catalyzes the stereoselective cleavage of only one diastereomer from the mixture, leaving the other unchanged, which is isolated with **ee** > 95%. The reaction was monitored by NMR in combination with HPLC analysis on a chiral column.



Such a high stereoselectivity of this enzyme with respect to the configuration of the chiral center on the sulfur atom was discovered for the first time.

At the key stage of another process, the cleavage of racemic (S,R)-N-BOC(KBZ)-2-amino-butan-1-ol was carried out using available enzymes – lipases [2]. The isolated (S)-enantiomer is an important intermediate in the synthesis of anti-tuberculosis drugs.

These approaches are planned to be used for the cleavage of other organoelement compounds along with chemical methods.

## References

- [1] Faleev N.G., Tsvetikova M.A., Ilyin M.M., Yufryakov V.S., Kolotyrykina N.G., Kulilova V.V., Demidkina T.V., Kochetkov K.A.. *Mendeleev Commun.* **2021**, 31, 1-3.
- [2] Patent RF № 2712231, **2020**

GENERATION OF NEW CARBON-CARBON BONDS VIA SUBSEQUENTIAL REARRANGEMENT OF LIGNANS WITH ALLYL BROMIDE IN BASIC CONDITIONS

Zakharzhevskii M.A., Ryabukhin D.S.

All-Russia Research Institute for Food Additives — Branch of V.M. Gorbатов Federal Research Center for Food Systems of RAS, Saint Petersburg, Russia

PhD Student

[zaxaroseres@yandex.ru](mailto:zaxaroseres@yandex.ru)

Over the past few decades, significant amount of publication dedicated to green chemistry and different issues of ecology include usage of industrial waste or renewable resources as feedstock[1]. Among natural compounds, lignins and lignans stand out, due to not only the appearance in many plants, including broccoli, tea, strawberries and flax seeds, but they are also waste products from the pulp and paper industry.

In this work, we present a unique reaction alpha-allylation, using one of 7-hydroxymatairesinol 1 derivatives – carboxylic acid 2, which can be easily produced from natural lignans 1 in strong alkali solution [2].

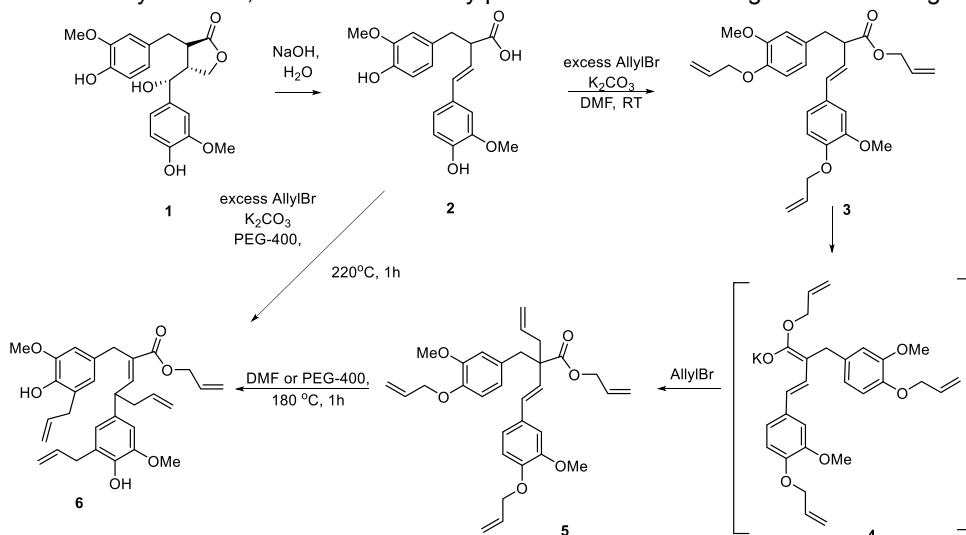


Figure 1. Reaction

7-hydroxymatairesinol (HMR) was obtained from Norway spruce knots extract. According to a known technique, the lactone cycle in HMR can be opened using concentrated sodium hydroxide with formaldehyde as a by-product. The resulting compound 2 was then subjected to allylation under basic conditions in dimethylformamide at room temperature. The products of this reaction are compounds 3 and 4. Interestingly, compound 3 can be fixed only in the case of insufficient addition of the alkylating agent, and even then in small amounts. Subsequent heating of product 5 leads to the formation of product 6. It should be noted that carrying out the allylation reaction in PEG-400 allows the conversion from 2 to 6 to undergo in one step in just 1 hour.

The proposed mechanism includes O-allylation by allyl bromide which leads to the formation of product 3. We assume that basic conditions lead to the formation of enolate 4 which is stabilized due to conjugation with a double bond. This form participates in an intramolecular [3,3] sigmatropic rearrangement similar to the Ireland-Claisen [3] rearrangement. Then the carboxyl moiety is attacked by allyl bromide, which leads to the formation of product 5. The limiting stage is sigmatropic rearrangement, while the rate of allylation is very high; therefore, salt or acid have not been detected. A further increase in temperature leads to a change in the carbon skeleton via intramolecular Cope-rearrangement and aromatic Claisen rearrangement and to formation of product 6.

#### References

- [1] Christensen, C. H., Rass-Hansen, J., Marsden, C. C., Taarning, E., & Egeblad, K.. *ChemSusChem: Chemistry & Sustainability Energy & Materials*, **2008**, 1(4), 283-289.
- [2] Eklund, P. C., Riska, A. I., & Sjöholm, R. E. *The Journal of Organic Chemistry*, **2002**, 67(21), 7544–7546.
- [3] Martín Castro, Ana M. *Chemical reviews* **2004**, 104.6, 2939-3002.

Acknowledgements. This work was supported by the Ministry of Science and Education of the Russian Federation (Grant Agreement 075-15-2020-775)

SELF-ASSEMBLY, STRUCTURE AND SPECTRAL PROPERTIES OF SUPRAMOLECULAR COMPLEXES OF BIS(AZA-18-CROWN-6)-CONTAINING DIENONE WITH DIAMMONIOPROPYL DERIVATIVE OF DIPYRIDYLETHYLENE

*Zdorovenko I.P.<sup>1,2</sup>, Fomina M.V.<sup>2</sup>, Gromov S.P.<sup>1,2</sup>*

<sup>1</sup>Moscow State University, Moscow, Russia

<sup>2</sup>Photochemistry Center of RAS, FSRC "Crystallography and Photonics", Russian Academy of Sciences, Moscow, Russia

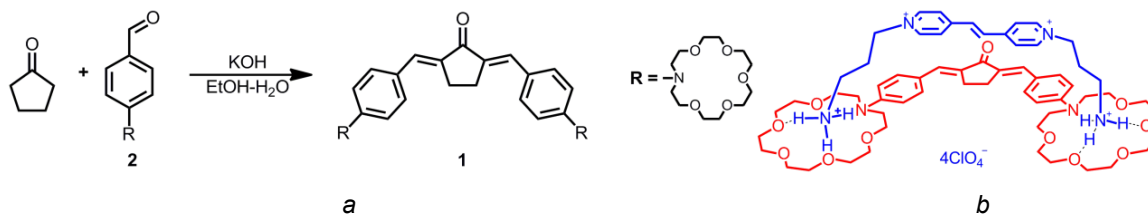
Student

[ilia.zdorovenko@gmail.com](mailto:ilia.zdorovenko@gmail.com)

Charge-transfer complexes based on organic compounds are considered as promising components of molecular electronic devices for efficient solar energy conversion, photochromic materials, photoactive switches in optoelectronics and optical chemosensors. In this regard, bisazacrown-containing dienones, which combine chromophore and ionophore fragments in their structure, are of undoubted interest.

The aim of this work was to synthesize bis(aza-18-crown-6)-containing dienone of the cyclopentanone series (**1**) and to study the features of its complexation with  $\text{Ca}^{2+}$  cations, tetraperchlorate of diammoniopropyl dipyridylethylene derivative.

Bisazacrown-containing dienone **1** was obtained by condensation of cyclopentanone with azacrown-containing aldehyde **2** in the presence of an aqueous alkali solution.



**Figure 1.** Synthesis of bis(aza-18-crown-6)-containing dienone **1** (a), structure of the pseudocyclic complex **1** (b) with the diammoniopropyl dipyridylethylene derivative

The structure of the resulting dienone **1** was determined by complex of independent methods (NMR, IR, electron spectroscopy, elemental analysis data). The complexation of dienone **1** with a diammoniopropyl derivative of bipyridylethylene and  $\text{Ca}^{2+}$  cations was studied by electron and <sup>1</sup>H NMR spectroscopy. It was found that bis(azacrown)dienone **1** forms stable 1:1 and 1:2 complexes with  $\text{Ca}^{2+}$  cations, and pseudocyclic 1:1 complex with a diammoniopropyl derivative of dipyridylethylene. The complexation **1** with a dipyridylethylene derivative is accompanied by quenching of the emission **1**, which indicates the formation of a charge transfer complex [1]; the addition of  $\text{Ca}^{2+}$  cations leads to the destruction of the charge transfer complex and accompanied by fluorescence enhancement **1**.

The stability constants of the resulting complexes were determined by spectrophotometric and fluorescence titration methods. Bisazacrown-containing dienones and supramolecular systems based on them can be used to determine the presence of metal ions and organic cations in the environment and biological fluids, which opens up opportunities for their use for analytical purposes.

#### References

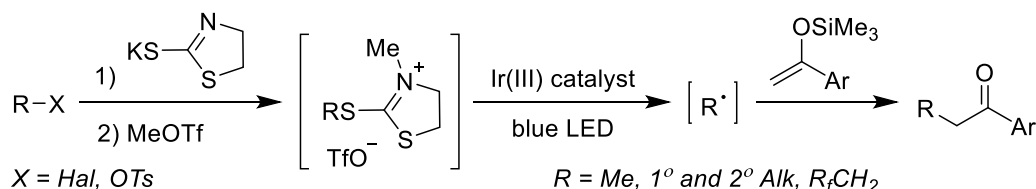
[1] Vedernikov, A.I.; Ushakov, E.N., Efremova A.A. et al., *J. Org. Chem.* **2011**, *76*, 6768–6779

Acknowledgements. This work was supported by the Russian Science Foundation (project No 19-13-00020).

N.D. Zelinsky Institute of Organic Chemistry, Moscow, Russia  
 Young scientist  
[artemiy.zemtsov@gmail.com](mailto:artemiy.zemtsov@gmail.com)

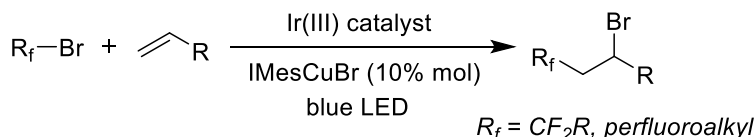
Visible light photoredox catalysis is a rapidly developing powerful methodology of activation of small molecules by photoexcited transition metal complexes [1] or organic dyes [2]. These processes typically proceed *via* single-electron reduction or oxidation of organic substrate resulting in a formation of free radical.

While this methods work well with  $\alpha$ -halocarbonyl compounds and benzyl halides, single-electron activation of unstabilized alkyl halides is much less frequent, probably due to their insufficient redox potential. In this investigation we demonstrated that 2-mercaptothiazolinium salts, which can be *in situ* generated from alkyl halides or tosylates, may be easily reduced in mild conditions in presence of iridium catalyst under irradiation by blue LEDs [3]. The resulting free radicals may be trapped with silyl enol ethers, providing the corresponding ketones in good yields. The reaction proceeds smoothly with the sources of different primary and secondary alkyl radicals, including methyl group.



**Figure 1.** Photoredox reaction of R-X with silyl enol ethers *via* 2-mercaptothiazolinium salts.

Fluoroalkyl bromides are also readily available and shelf-stable target compounds for radical reactions. However, most of their interactions with unsaturated double or triple bonds proceed with the use of strong reductants, which usually leads to overall two-electron reduction of the reaction system and formation only of the saturated products. In this work we developed an atom transfer-radical addition (ATRA) reaction of unactivated fluoroalkyl bromides with alkenes, which is generally redox-neutral [4]. The main idea is a combination of two catalysts, where iridium (III) complex under blue LED irradiation acts as a strong single-electron reductant for fluoroalkyl bromide and N-heterocyclic carbene copper complex promotes the final formation of carbon-bromine bond. The reaction works well with bromides, bearing difluoromethylene, tetrafluoroethylene, or perfluorinated group, and non-conjugated alkenes.



**Figure 2.** Photoredox/copper catalyzed ATRA reaction of fluoroalkyl bromides with alkenes.

### References

- [1] Prier C.K., Rankic D.A., MacMillan D.W.C. *Chem. Rev.* **2013**, *113*, 5322–5363.
- [2] Romero N.A., Nicewicz D.A. *Chem. Rev.* **2016**, *116*, 10075–10166.
- [3] Zemtsov A.A., Ashirbaev S.S., Levin V.V., Kokorekin V.A., Korlukov A.A., Dilman A.D. *J. Org. Chem.* **2019**, *84*, 15745–9753.
- [4] Kostromitin V.S., Zemtsov A.A., Kokorekin V.A., Levin V.V., Dilman A.D. *Chem. Commun.* **2021**, *57*, 5219–5222.

Acknowledgements. This work was supported by the Russian Science Foundation (project 20-13-00112).

# ESTABLISHMENT OF HUMAN OSTEOSARCOMA CELL LINE WITH MULTIPLE DRUG RESISTANCE

Zenina A.D., Sagaidak A.V.

Saint-Petersburg State Institute of Technology, Saint Petersburg, Russia  
Student  
asyazen@mail.ru

Tumor cell resistance is a significant problem in cancer chemotherapy. The development of multidrug resistance (MDR) makes tumor cells insensitive to a wide range of drugs, including anthracyclines, epipodophyllotoxins, camptothecins, vinca alkaloids, taxanes, etc.

One of the main mechanisms of the MDR formation is an increased activity of ATP-dependent transport proteins of the ABC family: P-gp, BCRP, MRP1. The resistance of cells to drugs is provided by the release of drugs from the cell, and leads to a decrease in the therapy effectiveness and the disease progression [1]. A potential solution to this problem is the use of ABC transporter inhibitors [2].

The aim of this work was to establish human osteosarcoma U2OS cell line, resistant to the antitumor drug paclitaxel, for further study of ABC transporter-mediated resistance and ways to overcome it.

Paclitaxel is a semisynthetic diterpene derivative [3]. Its binding to  $\beta$ -tubulin of microtubules, which leads to the prevention of their depolymerization, mitotic arrest, and subsequently to apoptosis, is noted as the main mechanism of the cytotoxic action [2].

Wild-type U2OS cell line was used to establish resistant cells. The treated cells were cultured in DMEM Glutamax medium in the presence of paclitaxel, while control cells were cultured without the drug. The initial concentration of paclitaxel was 0.01  $\mu$ M. When the experimental cells reached the growth rate corresponding to the growth rate of the control, which indicated the adaptation of the cells to the drug, the paclitaxel concentration was increased to 0.03  $\mu$ M.

Thus, cell strains resistant to paclitaxel at concentrations of 0.01 and 0.03  $\mu$ M were obtained; the work on the establishment of generations of U2OS cells resistant to higher concentrations of paclitaxel is continued. At the next stage of the work, the resistance of the obtained strains to drugs of various classes, as well as expression levels of transport proteins, will be quantitatively studied.

## References

- [1] Kuzin K.A. et al. *Determination of chemoresistance of ovarian cancer cells in vitro*. **2019**, 6(4), 8-25. doi: 10.17650/2313-805X-2019-6-4-8-25.
- [2] Marupudi N. I. et al. *Paclitaxel: a review of adverse toxicities and novel delivery strategies*. **2007**, 6(5), 609-621. doi: 10.1517/14740338.6.5.609.
- [3] Nemcova-Furstova V. et al. *Characterization of acquired paclitaxel resistance of breast cancer cells and involvement of ABC transporters*. **2016**, 310, 215-228. doi: 10.1016/j.taap.2016.09.020

Acknowledgements. This work was supported by the Russian Foundation for Basic Research (project no. 20-33-70250).

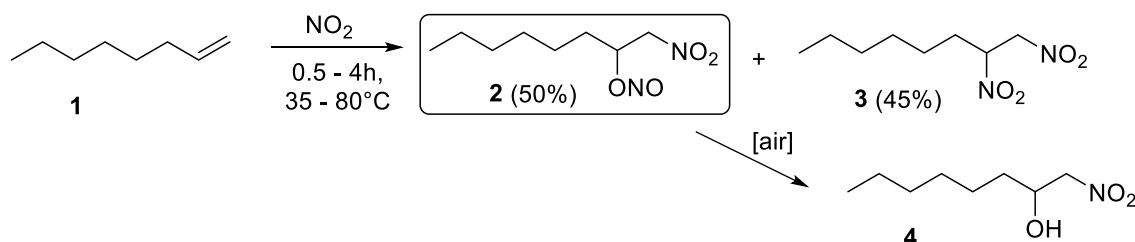
## RADICAL C-NITRATION BY NO<sub>2</sub> IN SUPERCRITICAL CO<sub>2</sub> MEDIUM

Ivanov R.E., Zharkov M.N.

Zelinsky Institute of Organic Chemistry, Moscow, Russia  
[m.n.zharkov@gmail.com](mailto:m.n.zharkov@gmail.com)

For the first time, the reactions of nitration of alkanes, alkenes, and their derivatives in the medium of supercritical carbon dioxide (sc-CO<sub>2</sub>) were carried out, and the influence of the main parameters of the process on the composition and yield of nitro products was studied.

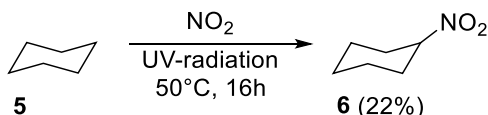
It was shown that octene-1 (**1**) under the action of N<sub>2</sub>O<sub>4</sub> in a sc-CO<sub>2</sub> medium almost quantitatively transforms into the mixture of 1-nitrooctanyl-2-nitrite (**2**) and 1,2-dinitrooctane (**3**) in a ratio of 10:9 (Figure 1). The resulting nitronitrite (**2**) upon standing in air is hydrolyzed to the corresponding nitroalcohol (**4**). The reaction proceeds for several minutes after which the quantity and composition of the products do not change. Variations of the temperature (35-80°C), the order of mixing the reagents and their concentration also do not significantly affect the result of the process.



**Figure 1.** Radical nitration of octene-1 under the action of NO<sub>2</sub> in sc-CO<sub>2</sub>.

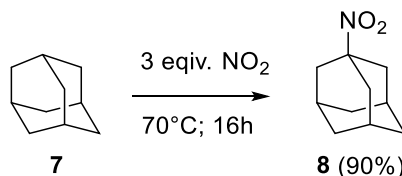
Under similar conditions, styrene, 1-methylstyrene, and 1,5-cyclooctadiene react with NO<sub>2</sub>, giving mixtures of the corresponding dinitro compounds and nitroalcohols with high conversion of the substrates.

The possibility of nitration of alkanes under the proposed conditions was demonstrated by the example of cyclohexane (**5**). The main product of the reaction is nitrocyclohexane (**6**) – a valuable intermediate in organic synthesis. It is formed with 22% yield at the minimum NO<sub>2</sub> quantity (0.5 equiv.) used under the UV irradiation with no presence of any catalyst (Figure 2). Importantly, the only comparable results ever reported in literature were based on the use of *N*-hydroxyimides as catalysts.



**Figure 2.** Radical nitration of cyclohexane with NO<sub>2</sub> in sc-CO<sub>2</sub>

Radical nitration of adamantane (**7**) under the similar conditions resulted in formation of valuable mono-nitroderivative **8**. In this case UV irradiation led to formation of complex mixture of mono and poly-nitro-products. The best yield of nitroadamantane (**8**) were registered when 3 equiv. of NO<sub>2</sub> were used.



**Figure 3.** Radical nitration of adamantane in sc-CO<sub>2</sub>

The obtained results indicate that sc-CO<sub>2</sub> is a promising, environmentally friendly medium for carrying out the hydrocarbons radical C-nitration processes.

Acknowledgements. This work was supported by the Russian Science Foundation (project No 20-73-00230).



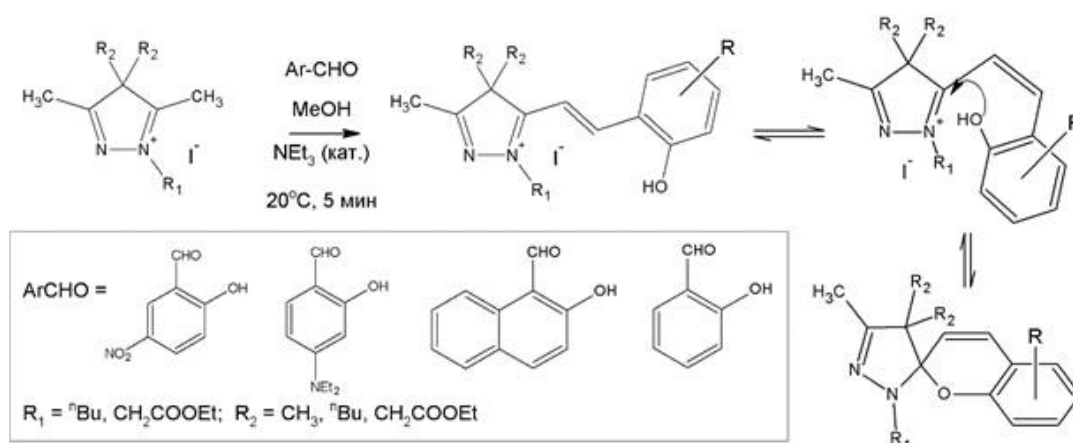
SYNTHESIS AND RESEARCH OF NOVEL MOLECULAR SWITCHES BASED ON PYRAZOLE DERIVATIVES WITH A SPIROPYRAN FRAGMENT

*Zhegulovich E.A., Seliverstov M.Yu., Lozinskaya N.A.*

Moscow State University, Moscow, Russia  
PhD student  
[klavrik97@mail.ru](mailto:klavrik97@mail.ru)

Representatives of the spiropyran class have outstanding properties among molecular switches widely used in the creation of light-sensitive materials. Their compounds exhibit a wide range of sensitivity to light, changes in temperature and pH, redox processes, and many other factors, and are also easily subject to structural modifications [1,2]. In this study, indoline-pyran dyes [3] became a prototype for the creation of new cyanine derivatives based on pyrazole, in which intramolecular nucleophilic addition with the formation of a spiropyran fragment is potentially possible.

A general procedure for the synthesis of these compounds was developed, the one includes the condensation of pyrazolium salts with an active methylene component with a number of aromatic hydroxyaldehydes in the presence of a base.



**Figure 1.** A general procedure

The obtained compounds are characterized by photo-, solvato- and acidochromism. Absorption in the UV region of the spectrum is observed in the wavelength range 225-245 nm with an extinction coefficient of 104-105 M<sup>-1</sup>cm<sup>-1</sup>. Studies on various cell cultures have shown low cytotoxicity of the obtained compounds, which gives possibilities for their use in Photopharmacology.

#### References

- [1] Kortekaas L., Browne W.R., "The evolution of spiropyran: fundamentals and progress of an extraordinarily versatile photochrome" // *Chemical Society Reviews*, 2019, v. 48, № 12, pp. 3406-3424.
- [2] Klajn R., "Spiropyran-based dynamic materials" // *Chemical Society Reviews*, 2014, v.43, №1, pp. 148-184.
- [3] Fischer E., Hirshberg Y., "Formation of coloured forms of spiropyrans by low-temperature irradiation" // *Journal of the Chemical Society*, 1952, pp. 4522-4524.

Acknowledgments: This work was supported by the Russian Foundation for Basic Research (Project 20-03-00915a)

# SYNTHESIS STERICALLY-HINDERED O-BENZOQUINONE CARBOXYLIC ACID AND ITS DERIVATIVES

*Zherebtsov M. A.*<sup>1,2</sup>, *Arsenyev M. V.*<sup>1,2</sup>, *Baranov E. V.*<sup>1</sup>, *Chesnokov S. A.*<sup>1</sup>, *Cherkasov V. K.*<sup>1,2</sup>

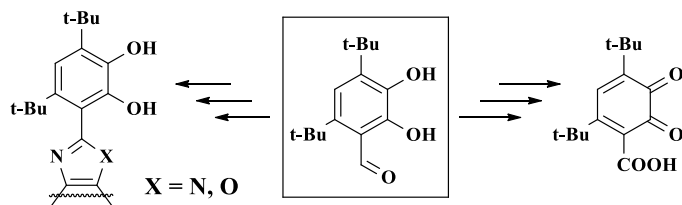
<sup>1</sup>G. A. Razuvaev Institute of Organometallic Chemistry, Nizhny Novgorod, Russia

<sup>2</sup>Lobachevsky State University, Nizhny Novgorod, Russia

PhD Student

[maxzen3108@mail.ru](mailto:maxzen3108@mail.ru)

Pyrocatechuic acid (2,3-dihydroxybenzoic or catechol carboxylic acid) and its derivatives are represented widely in the chemistry of biologically active compounds (siderophores and antioxidants) [1-2], as well as ligands for supramolecular [3] and coordination chemistry [4]. In all studies these compounds are in the reduced (catecholic) form while highly reactive oxidized forms (semiquinone and quinone) have not been isolated. It is known that the oxidized form of catechols is stabilized by sterically hindered substituents (like *tert*-butyl groups) and thus these compounds are obtained [5]. In the present work we report on the synthesis of sterically-hindered *o*-benzoquinone pyrocatechuic acid and its heterocyclic derivatives.



4,6-Di-*tert*-butyl-2,3-dihydroxybenzaldehyde, a well-known precursor for the synthesis of new sterically hindered catechols and quinones, was used in this work as the starting material.

## References

- [1] Aoki T., Yoshizawa H., Yamawaki K., Yokoo K., Sato J., Hisakawa S., Hasegawa Y., Kusano H., Sano M., Sugimoto H., Nishitani Y., Sato T., Tsuji M., Nakamura R., Nishikawa T., Yamano Y. *Eur. J. Med. Chem.* **2018**, *155*, 847
- [2] Liu R., Miller P. A., Vakulenko S. B., Stewart N. K., Boggess W. C., Miller M. J. *J. Med. Chem.* **2018**, *61*, 3845
- [3] Yamasaki Y., Shio H., Amimoto T., Sekiya R., Haino T. *Chem. – Eur. J.* **2018**, *24*, 8558
- [4] Pham T. A., Altman A. B., Stieber S. C. E., Booth C. H., Kozimor S. A., Lukens W. W., Olive D. T., Tyliczszak T., Wang J., Minasian S. G., Raymond K. N. *Inorg. Chem.* **2016**, *55*, 9989
- [5] Zhiganshina E. R., Arsenyev M. V., Shavyrin A. S., Baranov E. V., Chesnokov S. A. *Mendeleev Commun.* **2019**, *29*, 91

Acknowledgements. The reported study was funded by Russian Foundation for Basic Research (grant no. 20-33-90062).

# KINETICS AND MECHANISM OF INTERACTION OF NATURAL THIOLS WITH HYDROGEN PEROXIDE

*Zinatullina K.M.<sup>1</sup>, Kasaikina O.T.<sup>1</sup>, Orekhova A.V.<sup>1</sup>, Khrameeva N.P.<sup>2</sup>*

<sup>1</sup>N.N.Semenov Institute of Chemical Physics RAS, Moscow, Russia

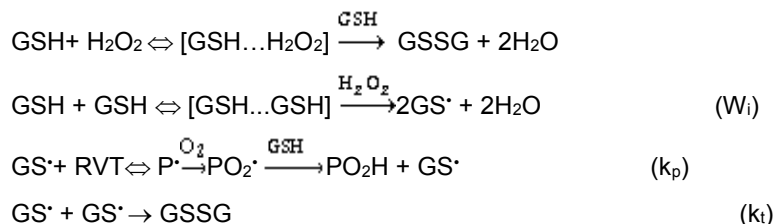
<sup>2</sup>N.M.Emanuel Institute of Biochemical Physics RAS, Moscow, Russia

[karinazinat11@gmail.com](mailto:karinazinat11@gmail.com)

The thiol-disulfide exchange reactions involving the thiol -SH groups of cysteine residues in proteins and low-molecular-weight peptides play an important role in the functioning of living organisms. Glutathione (GSH) is the most ubiquitous tripeptide, found in high (0,1-10 mM) concentrations in many prokaryotic and eukaryotic cells. GSH plays an important role in preventing oxidative damage of proteins and lipids. In living organisms, the hydroperoxides are reduced by GSH together with the enzymes glutathione peroxidases. The direct interaction of GSH and H<sub>2</sub>O<sub>2</sub> proceeds according to the stoichiometric equation: 2 GSH + H<sub>2</sub>O<sub>2</sub> → GSSG + 2 H<sub>2</sub>O. Detailed studies of the kinetics and mechanism of the interaction of GSH and other thiols cysteine, homocysteine and acetylcysteine with H<sub>2</sub>O<sub>2</sub> in deionized water (without enzymes) revealed a number of new features of the reaction.

1. In deionized water, the consumption of thiols (TSH) is accompanied by the formation of free radicals [1-2]. The rate of radical formation ( $W_i$ ) is low, about 1% of the GSH consumption rate ( $W_{GSH}$ ), but thiyl radicals can initiate chain reactions of thiols with unsaturated compounds (thiol-ene reactions).

2. The kinetics and reaction products were studied in the thiol-ene reaction of GSH with an unsaturated phenol resveratrol (RVT) in the presence of H<sub>2</sub>O<sub>2</sub> [3]:



P<sup>·</sup> is an alkyl radical formed as a result of the addition of GS<sup>·</sup> to the unsaturated RVT bond in the side chain, PO<sub>2</sub>H is a corresponding hydroperoxide.

3. The effects of buffer solutions and individual cations on  $W_i$  and  $W_{GSH}$  were studied using RVT as a spectral-kinetic probe for determining the rate of radical initiation ( $W_i$ ). The molecule of GSH contains two carboxyl groups. Its pKa of function groups are 2.5, 3.7; 9.2; 9.5. So, in water GSH forms acidic solutions (pH < 7), and in alkaline solutions it often changes the pH to the acidic side. In phosphate buffer solutions at pH > 7, no radicals are formed, and the rate of GSH consumption is higher than in deionized water. For the first time, it was found that the neurotransmitter acetylcholine (ACh) influences on the rate of interaction of GSH with H<sub>2</sub>O<sub>2</sub> and increases the yield of radicals in this reaction. Ions of K<sup>+</sup> interact specifically with GSH: they increase the rate of oxidation of GSH by hydrogen peroxide, but at the same time reduce the yield of radicals in this reaction as compared with other cations.

## References

- [1] Zinatullina K.M., Khrameeva N. P., Kasaikina O.T., Shapiro B. I., Kuzmin V. A. *Russ.Chem. Bull.* **2017**, 66(7),1300.
- [2] Zinatullina K.M., Kasaikina O.T., Motyakin M. V., Ionova I. S., Degtyarev E. N., Khrameeva N. P. *Russ.Chem. Bull.* **2020**, 10,1865.
- [3] Zinatullina K.M., Kasaikina O.T., Khrameeva N. P., Indeykina M. I., Kononikhin A. S. *Kinetics and Catalysis*, **2021**, 62(2),198.

Acknowledgements. This study is supported by the Russian Foundation for Basic Research, grant No 20-03-00753.



# **POLYMER SCIENCE**

# COMPLEX INVESTIGATION OF CERAMIC-POLYMER ION-CONDUCTIVE MEMBRANES FOR HYBRID LITHIUM-TEMPO REDOX FLOW BATTERIES

*Akhmetov N.O., Ovsyannikov N.A., Krasnikova I.V., Pogosova M.A., Ryazantsev S.V., Gvozdk N.A., Stevenson K.J.*

Skolkovo Institute of Science and Technology, Moscow, Russia

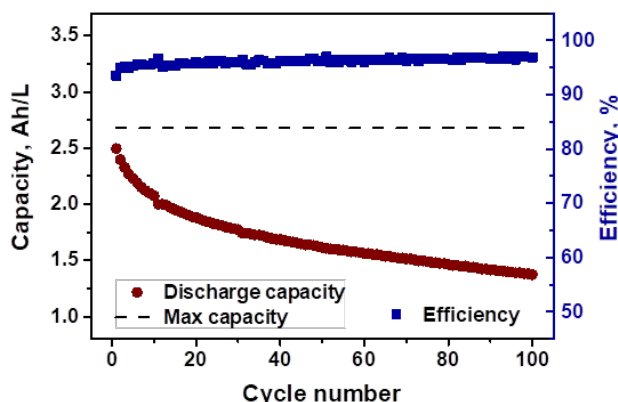
Ph.D. student

[nikita.akhmetov@skoltech.ru](mailto:nikita.akhmetov@skoltech.ru)

Non-aqueous hybrid redox flow batteries (HFBS) based on metallic lithium anode and liquid catholyte are considered as prospective energy storage devices [1]. By accumulating the energy from traditional or renewable sources, HFBS are able to either compensate energy drawbacks or overtake energy excess issues. Comparing with traditional Li-ion batteries, HFBS store energy in a separate tank enabling an independent control of battery's power and energy capacity. Moreover, lithium anode and non-aqueous media allow operating at high voltage (above 4 V) that significantly enhances the power density of conventional flow batteries [1].

The main challenge retarding the HFBS development is the absence of an effective ion-conductive membrane. This membrane is responsible for the cell's charge balance and influences the battery's cyclability, power, and efficiency. The ceramic-polymer fabrication approach was applied recently to membranes for solid-state batteries [2, 3]. Integration of ion-conductive  $\text{Li}_{1.3}\text{Al}_{0.3}\text{Ti}_{1.7}(\text{PO}_4)_3$  (LATP) ceramics into the stable poly(vinylidene fluoride) (PVdF) matrix provided the final membranes with the best characteristics of initial components: high ionic conductivity, good cyclability, stability, and flexibility [2, 3].

In this report, we studied the LATP+PVdF membranes (tape casting fabrication) suitable for the hybrid lithium (2,2,6,6-tetramethylpiperidin-1-yl)oxyl (TEMPO) flow batteries. The various physical (XRD, FTIR, SEM, EDX) and electrochemical (impedance spectroscopy, cyclic voltammetry, galvanostatic cycling) techniques were used to analyze critical membranes' properties for the effective operation of Li-TEMPO HFBS. The most promising 45 wt.% LATP+PVdF membrane demonstrated high ionic conductivity ( $3.4 \cdot 10^{-4}$  S/cm), TEMPO permeability of  $6.6 \cdot 10^{-7}$  cm<sup>2</sup>/min, and outstanding stability towards metallic lithium (400 cycles) that substantially outperforms the commercially available membranes (Nafion, Neosepta). During galvanostatic tests, the Li-TEMPO cell with LATP+PVdF (**Figure 1**) showed excellent cyclability, stable columbic efficiency of over 95%, and an initial capacity about 2.5 Ah/L (state of charge of about 93%), which then decreased to 1.4 Ah/L due to the crossover. Nevertheless, the LATP+PVdF cycling performance (100 charge/discharge cycles) exceeds that of commercial analogues. There are also several pathways to suppress the crossover of LATP+PVdF.



**Figure 1.** Cycling performance of 45 wt.% LATP+PVdF composite membrane in the hybrid Li-TEMPO cell.

Thus, the composite membrane is promising for non-aqueous Li-TEMPO HFBS due to the high lithium-ionic conductivity, outstanding stability to the battery's media, and cyclability. We hope these results will be useful for the further development of HFBS as well as other energy storage devices.

## References

- [1] Ding Y., Zhang C., Zhang L., Zhou Y., Yu G. *Chem* **2019**, 5, 1964
- [2] Shi X., Ma N., Wu Y., Lu Y., Xiao Q., Li Z., Lei G. *Solid State Ionics* **2018**, 325, 112
- [3] Liang X., Han D., Wang Y., Lan L., Mao J., *RSC Adv.* **2018**, 8, 40498

Acknowledgements. This work was supported by Skoltech-MIT Next Generation Project “Energy-dense and Durable Nonaqueous Redox Flow Batteries enabled by Flowing Solid-state Capacity Boosters”.

## VEGETABLE MODIFIER FOR POLYOLEPHIN-BASED COMPOSITIONS

*Alekseev E.I.<sup>1</sup>, Zenitova L.A.<sup>1</sup>, Yanov V.V.<sup>1</sup>*

*<sup>1</sup>Kazan National Research Technological University, Kazan, Russia.*

*PhD student*

[evg.alekseev@mail.ru](mailto:evg.alekseev@mail.ru)

One of the ways to solve the problem of environmental pollution is to create polymers capable of retaining their physical and mechanical characteristics during operation and, at the end of the life cycle, degrade into low-molecular compounds that do not harm nature. The polymer must be a substrate for an efficient microbiological degradation process.

The introduction of a natural degradable filler into the matrix of the base polymer makes it possible to create a favorable environment for fungi, actinomycetes and bacteria and, thereby, to increase the rate of decomposition. Natural rubber (NR) is produced by plants and does not accumulate in nature, which suggests that it is subject to microbiological degradation. It was found that non-rubber components, which remain in the rubber even after cleaning, contribute to the degradation of NR. Some of them are physically or chemically attached to NR molecules. Commercially available solid NR contains neutral lipids (2.4%), glyco- and phospholipids, in particular lecithin and cephalin (1.0%), proteins (2.2%), carbohydrates (0.4%), and other compounds (0.1%). Free fatty acids in rubber are long-chain saturated and unsaturated fatty acids - stearic, oleic and linoleic. [1]

The structural analogue of non-rubber components are phospholipids contained in phospholipid concentrate (PLC), a by-product formed during physical refining in the production of vegetable oils. [2,3] PLC contains a phospholipid monoaminophosphatide (lecithin or cephalin) (63-37%), vegetable oils (34-37%), moisture (less than 1%). At present, the amount of PLC emitted in Russia is about 30 thousand tons / year. PLC did not receive wide commercial use.

It is assumed that the introduction of PLC into compositions based on polyolefins and NR, on the one hand, will improve the processability of the compositions due to the plasticizing action of triglycerides of fatty acids, and, on the other hand, will increase the rate of decomposition by microorganisms due to the increased content of organic compounds, including lipids. At the same time, it should be noted that the phospholipid molecule contains polar and non-polar parts, has the properties of surfactants, which contributes to better compatibility and the most complete distribution of NR in the polyolefin matrix.

Thus, PLC can be classified as a promising plant modifier.

### References

[1] Dautova A.N., dis., **2019**, 135

[2] Chan H. Th., dis., **2018**, 138

[3] Tsyganova M.E., Rakhmatullina A.P., Liakumovich A.G., Potapov E.E., Stepanov G.S. *Technical science* **2011**, 12, 187-193

# A SIMPLE APPROACH TO POLYMER GAS SEPARATION MEMBRANES BASED ON 5-NORBORNENE-2-METHANOL DERIVATIVES

*Alentiev D.A.*<sup>1,2</sup>, *Rudakova M.A.*<sup>2</sup>, *Zarezin D.P.*<sup>2</sup>, *Nikiforov R.Yu.*<sup>2</sup>, *Belov N.A.*<sup>2</sup>, *Bermeshev M.V.*<sup>2</sup>

<sup>1</sup>D.I. Mendeleev University of Chemical Technology of Russia, Moscow, Russia

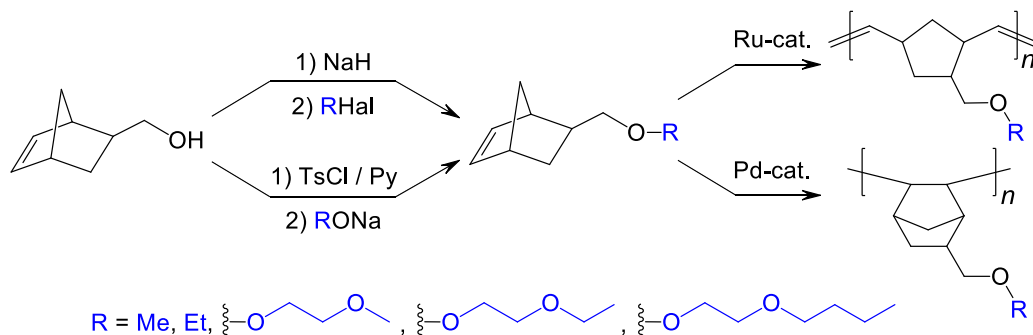
<sup>2</sup>A.V. Topchiev Institute of Petrochemical Synthesis, Moscow, Russia

PhD

[d.alentiev@ips.ac.ru](mailto:d.alentiev@ips.ac.ru)

The investigation into relationships between the structure of membrane materials and their properties is one of the most actual problems of modern membrane science and technology, since the knowledge of these relationships allows for the targeted design of membranes possessing required properties. Substituted polynorbornenes are convenient objects for this purpose, because of two reasons. Firstly, initial monomers for these polymers can be easily synthesized by cycloaddition reactions and have high driving force of the polymerization by two different ways (metathesis and addition polymerization). These features make it possible to synthesize a great number of polymer structures. Secondly, a number of polynorbornenes possesses perspective gas transport properties, including high permeability, selectivity for hydrocarbons or CO<sub>2</sub>/N<sub>2</sub> separation [1-2]. A researchers' group from USA showed that the introduction of C–O–C-fragments in the side chain of silicon substituted polynorbornenes promotes enhanced sorption of CO<sub>2</sub> and, hence, high CO<sub>2</sub>/N<sub>2</sub> separation selectivity [3]. However, it was ambiguous, whether the presence of silicon in the polymer is necessary for these properties. In accordance to this, it was interesting to synthesize Si-free polynorbornenes containing C–O–C-fragments in the side chain and investigate their gas transport properties.

In this study we report a simple approach to polynorbornenes bearing ether side substituents. The approach is based on the modification of commercially available 5-norbornene-2-methanol followed by the polymerization of synthesized norbornene derivatives (Figure 1). A series of norbornenes bearing substituents with one or two ether groups was successfully synthesized by Williamson reaction. Synthesized monomers were involved in metathesis and addition polymerization. The polymerization conditions leading to high-molecular-weight polymers in moderate or high yields were found. Thus, a series of ether substituted polynorbornenes differing in their main and side chain structure was obtained.



**Figure 1.** Synthesis and polymerization of 5-norbornene-2-methanol derivatives.

A number of synthesized polynorbornenes turned out amorphous glassy polymers possessing acceptable film-forming properties. For these polymers, gas transport properties were studied for a wide range of gases (He, H<sub>2</sub>, N<sub>2</sub>, O<sub>2</sub>, CO<sub>2</sub>, CH<sub>4</sub> and heavier hydrocarbons). It was found that the presence of C–O–C-fragments in the side chain of these Si-free polynorbornenes promotes enhanced permeation of CO<sub>2</sub> and heavy gaseous hydrocarbons (C<sub>3+</sub>).

## References

- [1] Finkelshtein E.S., Bermeshev M.V., Gringolts M.L., Starannikova L.E., Yampolskii Yu.P. *Russ. Chem. Rev.* **2011**, *80*, 341–361.
- [2] Wang X., Wilson T.J., Alentiev D., Gringolts M., Finkelshtein E., Bermeshev M., Long B.K. *Polym. Chem.* **2021**, *12*, 2947–2977.
- [3] Maroon C.R., Townsend J., Gmernicki K.R., Harrigan D.J., Sundell B.J., Lawrence J.A., Mahurin S.M., Vogiatzis K.D., Long B.K. *Macromolecules* **2019**, *52*, 1589–1600.

Acknowledgements. This work was supported by the Russian Foundation for Basic Research (project No 19-33-60035).



## POLYMER MACROPOROUS MICROARRAY FOR DETECTION OF HUMAN GENOME MUTATIONS

*Alexandrova N.A.<sup>1</sup>, Sinitsyna E.S.<sup>1,2</sup>, Vashukova E.S.<sup>3</sup>, Glotov A.S.<sup>3</sup>,  
Korzhikova-Vlakh E.G.<sup>1,2</sup>, Tennikova T.B.<sup>1</sup>*

*<sup>1</sup> Institute of Chemistry, Saint-Petersburg State University, St. Petersburg, Russia*

*<sup>2</sup> Institute of Macromolecular Compound, Russian Academy of Sciences, St. Petersburg, Russia*

*<sup>3</sup> D.O. Ott Research Institute of Obstetrics and Gynecology, Russian Academy of Medical Sciences, St. Petersburg, Russia*

Student

[st068459@student.spbu.ru](mailto:st068459@student.spbu.ru)

The identification of a genetic pathology caused by the mutations at the level of genes and chromosomes is an important problem of society. According to the world medical practice, 30-50 children have hereditary pathology out of 1000 born children. There are a number of diseases, timely diagnosis of which makes it possible to effectively choose a course of treatment that contributes to improving the patient's health.

In present work macroporous materials with immobilized on the surface oligonucleotide probes were utilized as platforms for rapid detection and the obtaining of correct data on the availability or the lack mutations in the studied genes. In order to prepare macroporous layers on the surface of glass it was necessary to manufacture the special cells (18 × 25 × 0.1 mm) by acidic hydrolysis. To introduce double bonds required for the further triple copolymerization, the etched glass slides were treated with 15% solution of 3-(trimethoxysilyl)propyl methacrylate in toluene at room temperature. The time of silanization reaction was varied from 15 min to 16 h. After 2 h of interaction the maximum of 3-(trimethoxysilyl)propyl methacrylate binding was achieved. By the photo-initiated free-radical polymerization the layers based on copolymer of glycidyl methacrylate (GMA) and ethylene dimethacrylate (EDMA) were synthesized. The reaction mixture containing monomers (GMA and EDMA), porogens (cyclohexanol and dodecanol) and 2-hydroxy-2-methylpropiophenone (Darocur-1173) as initiator was used for polymerization. The ratios of functional monomer:cross-linker and porogens:monomers were equal to 60:40 vol%. To prepare the monoliths with different pore size, the ratios of cyclohexanol (CyOH) and dodecanol (DoOH) were varied. The polymer macroporous layers were prepared under UV-polymerization during 20 min. The porous characteristics of copolymers obtained were determined by etalon porosimetry and scanning electron microscopy.

The detection of nucleotide replacements in genes of Endoplasmic Reticulum Aminopeptidase 2 (ERAP2) and Serine Peptidase (CORIN) was performed in the microarray format. The effect of such parameters as amount and type of oligonucleotide probe and amount of PCR product on relative signal intensity as well as signal-to-noise ratio were analyzed and the most appropriate conditions were established.

Acknowledgements. Thermogravimetric and Calorimetric Research Centre and Centre of Nanotechnology of Saint-Petersburg State University are acknowledged for porosimetry analysis and scanning electron microscopy, respectively.

# LUMINESCENCE PROPERTIES OF POLY[2-(CYCLOHEX-2-EN-1-YL)ANILINE]

*Andriyanova A.N.<sup>1,2</sup>, Baranova M.S.<sup>1</sup>, Mustafin A.G.<sup>1,2</sup>*

<sup>1</sup>Bashkir State University, Ufa, Russia  
<sup>2</sup>Ufa Institute of Chemistry RAS, Ufa, Russia  
 PhD student  
[anastasia.shishkina1993@mail.ru](mailto:anastasia.shishkina1993@mail.ru)

With the progress of the organic electronics field, there has been an increase in interest in the development of new conjugated polymers for use in various electronic devices. PANI and its derivatives are considered to be the most promising and widely studied polymers in this field. The high interest is due to the unique complex of physicochemical properties: ionic and electronic conductivity, redox activity, thermal and chemical resistance, low cost and ease of conversion of a monomer into a polymer. In this regard, the aim of this study is to synthesize a new PANI derivative, poly-(2-cyclohex-2-en-1-yl)aniline, and to analyze the effect of the nature of doping agents on its photoluminescent properties. [1-3].

Poly-(2-cyclohex-2-en-1-yl) aniline was synthesized by classical oxidative polymerization under the action of ferric chloride in an aqueous solution of such acids: HNO<sub>3</sub> (1), HCl (2), H<sub>2</sub>SO<sub>4</sub> (3), HClO<sub>4</sub> (4). Absorption, excitation, and fluorescence spectra were obtained for all studied compounds. The main results are presented in Table 1. Based on the obtained spectral characteristics, the forbidden width and the quantum yield of fluorescence, calculated by the formula

$$\varphi_f = \varphi_{\text{trp}} \times \frac{A_{\text{trp}}}{A_f} \times \frac{D_f}{D_{\text{trp}}}$$

where  $\varphi_{\text{trp}}$  is the relative quantum yield of tryptophan in an aqueous solution (0.14 [2]);  $A_{\text{ref}}$  and  $A_f$  are the optical densities of tryptophan and the sample under study;  $D_{\text{ref}}$  and  $D_f$  are the measured integral fluorescence intensities.

**Table 1.** Optical properties of synthesized polymers.

Polymer	Absorbance		$\lambda_{\text{Ex}}$ , HM	$\lambda_{\text{Em}}$ , HM	$\varphi_f$	$E_g$ , eV <sup>a</sup>
	$\lambda_1$ , HM	$\lambda_2$ , HM				
<b>1</b>	257	606	300	344	0.20	1.62
<b>2</b>	259	591	300	342	0.30	1.63
<b>3</b>	288	595	300	345	0.11	1.69
<b>4</b>	259	580	300	343	0.22	1.62

Based on the data in Table 1, several important conclusions can be drawn: i) varying the synthesis conditions has a significant effect on the photoluminescent properties of the synthesized samples; ii) a decrease in the band gap is accompanied by an increase in the quantum yield, which is possibly due to a decrease in the transition energy of electron from the valence band to the conduction band.

## References

- [1] Andriyanova A.N., Biglova Yu.N., Mustafin A.G. *RSC Advances* **2020**, *10*, 7468 – 7491  
 [2] Chen Y., Barkley M. D. *Biochemistry* **1998**, *37*, 9976-9982  
 [3] Andriyanova A.N., Gribko D.E., Petrov I.S., Mullagaliev I., Sattarova A.F., Salikhov R.B., Abdrakhmanov I.B., Mustafina A.G. *New J. Chem.* **2021**, *45*, 6356-6366

Acknowledgements. This work was supported by the Ministry of Science and Higher Education of the Russian Federation as part of the state task (project No AAAA-A19-119020890014-7) and Russian Foundation for Basic Research (project No 19-33-90147\19).

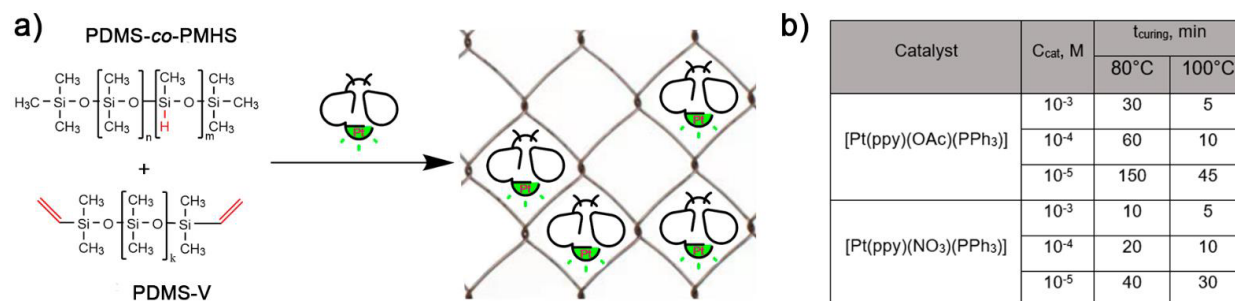
CHARACTERIZATION OF LUMINESCENT SILICONE RUBBERS, THAT WERE OBTAINED BY CATALYSTS  
[Pt(ppy)(OAc)(PPh<sub>3</sub>)] AND [Pt(ppy)(NO<sub>3</sub>)(PPh<sub>3</sub>)]

*Antonov N.S.<sup>1</sup>, Dobrynin M.V.<sup>1</sup>, Islamova R.M.<sup>1</sup>*

<sup>1</sup>Saint Petersburg State University, Saint Petersburg, Russia  
Student  
[st086331@student.spbu.ru](mailto:st086331@student.spbu.ru)

Hydrosilylation reaction plays a great role in production of silicone rubbers. Silicon rubbers are widespread: one can find it in various applications from kitchenware to targeted drug delivery [1]. Luminescent ones can be used in optoelectronics, in particular for creation of luminescent thermometers [2].

In this work complexes [Pt(ppy)(OAc)(PPh<sub>3</sub>)] and [Pt(ppy)(NO<sub>3</sub>)(PPh<sub>3</sub>)] were synthesized from [Pt(ppy)Cl(PPh<sub>3</sub>)] via literature method [3]. Structure of complexes was confirmed by HR MS ESI, <sup>1</sup>H and <sup>195</sup>Pt NMR spectroscopy. Synthesized complexes were used as catalysts for hydrosilylation of  $\alpha,\omega$ -divinylpolydimethylsilyoxane (PDMS-V) and poly(dimethyl-co-methylhydro)silyoxane (PDMS-co-PMHS) (**Fig.1, a**). Curing times were measured at temperatures 80 °C and 100 °C and with catalyst concentrations (10<sup>-3</sup>–10<sup>-5</sup>) M. It was found that the optimal catalyst concentration is 10<sup>-5</sup> M. Investigated complexes are more efficient catalysts of the hydrosilylation reaction than already studied [Pt(ppy)Cl(PPh<sub>3</sub>)] [4] (5 min against 20 min at 100 °C and catalyst concentration 10<sup>-3</sup>M). Curing times are shown in **Fig.1, b**. Swelling experiments were performed to determine cross-link density (both about 5.65×10<sup>-5</sup> mol/sm<sup>3</sup>) and average molecular weight of the rubber segment between cross-links (both about 17000 g/mol). Luminescent properties are similar for silicone rubbers obtained with [Pt(ppy)(OAc)(PPh<sub>3</sub>)] and [Pt(ppy)(NO<sub>3</sub>)(PPh<sub>3</sub>)]: peak at 360 nm is present in excitation spectra and peak at 436 nm in emission spectra. Silicone rubber's luminescence lifetimes are about 760 ns in both cases, quantum yield is 0.22 and 0.34% for [Pt(ppy)(NO<sub>3</sub>)(PPh<sub>3</sub>)] and [Pt(ppy)(OAc)(PPh<sub>3</sub>)] respectively.



**Figure 1. a)** mechanism of luminescent silicone rubbers obtaining,  
**b)** curing times of PDMS-V and PDMS-co-PMHS hydrosilylation cross-linking.

### References

- [1] I. Blanco, *Polymers*. **2018**, *10* (7), 755. DOI: 10.3390/polym10070755.  
 [2] F. A. de Jesus, B. V. Santana, G. F. da C. Bispo, C. I. da S. Filho, S. A. Júnior, M. E. G. Valério, J. M. A. Caiut, V. H. V. Sarmento, *Polymer*. **2019**, *181*, 121767. DOI: 10.1016/j.polymer.2019.121767.  
 [3] H. R. Shahsavari, R. Babadi Aghakhanpour, M. Nikraves, J. Ozdemir, M. Golbon Haghghi, B. Notash, M. H. Beyzavi, *Organometallics*. **2018**, *37* (17), 2890–2900. DOI: 10.1021/acs.organomet.8b00461.  
 [4] M. V. Dobrynin, E. V. Sokolova, M. A. Kinzhalov, A. S. Smirnov, G. L. Starova, V. Yu. Kukushkin, R. M. Islamova, *ACS Appl. Polym. Mater.* **2021**, *3* (2), 857–866. DOI: 10.1021/acsapm.0c01190.

Acknowledgements. This work was supported by the Russian Science Foundation (project No 20-19-00256). Physicochemical measurements were performed at the Center for Optical and Laser Materials Research, Center for Magnetic Resonance, Chemical Analysis and Materials Research Centre (all belonging to Saint Petersburg State University).

NANOPARTICLES BASED ON ALIPHATIC POLYESTERS  
FOR THE DELIVERY OF ANTICANCER DRUGS

*Bagaeva I.O.*<sup>1</sup>, *Sinitsyna, E.S.*<sup>1,2</sup>, *Korzhikova-Vlakh E.G.*<sup>2</sup>, *Korzhikov-Vlakh V.A.*<sup>1</sup>, *Tennikova T.B.*<sup>1</sup>

<sup>1</sup>*Institute of Chemistry, Saint-Petersburg State University,  
Universitetskii pr. 26, 198504 St. Petersburg, Russia*

<sup>2</sup>*Institute of Macromolecular Compounds, Russian Academy of Sciences,  
Bolshoy pr. 31, 199004 St. Petersburg, Russia  
Student [Bagaeva\\_irina2000@rambler.ru](mailto:Bagaeva_irina2000@rambler.ru)*

Currently, the chemotherapy with cytostatic drugs is carried out by intravenous drug administration. The main drawback of such treatment is the toxic systemic drug action and low bioavailability. The interest to nanoparticles for the preparation of cancer therapeutics can be related to their ability to increase the local drug concentration in cancer cells. Furthermore, the nanocontainers can improve drug efficacy, increase the solubility and bioavailability of a medicine, reduce side effects, prolong the circulation half-life, as well as allow for controlled release of a drug.

The aim of present study was to develop the delivery systems for antitumor drug dioxadet specific to the treatment of ovarian cancer. The chemotherapeutic agent was encapsulated into nanoparticles based on aliphatic polyester. The proposed polymer nanoparticles should provide a dosed, controlled and prolonged release of the cytostatic drug.

The nanoparticles based on amphiphilic block-copolymers of poly(lactic acid) (PLA-b-PEG) and poly- $\epsilon$ -caprolactone (PCL-b-PEG) with poly(ethylene glycol) were prepared by the nanoprecipitation technique. The ratio of the organic and water phase was 1:5. For the preparation of nanoparticles, it was tested as solvents: acetonitrile, tetrahydrofuran, the mixture of ACN:THF with ratio 50:50 (v/v), and a mixture of acetone with ACN and THF with ratio of 20:80 (v/v). The influence of concentrations of PLA-b-PEG and PCL-b-PEG, dissolved in organic phase, on the size and the stability of forming nanoparticles was investigated. The size of nanoparticles was determined by dynamic light scattering (DLS) and nanoparticle tracking analysis (NTA) methods.

The encapsulation efficiency and maximal drug loading of chemotherapeutic agent (dioxadet) into nanoparticles were determined under the variation of drug amount. The relationships between the copolymer hydrophobicity and the ability to encapsulate the optimal amount of dioxadet were established.

Acknowledgements. The work was supported by Russian Science Foundation (project №21-73-20104).

INFLUENCE OF MODIFIERS WITH FUNCTIONAL GROUPS ON THE PROCESS OF EPOXY CURING:  
A STUDY BY HIGH-TEMPERATURE FTIR

*Bezrukov N.P., Kostina J.V., Legkov S.A., Smirnova N.M., Antonov S.V.*

A.V.Topchiev Institute of Petrochemical Synthesis, RAS, Moscow, Russia  
Student

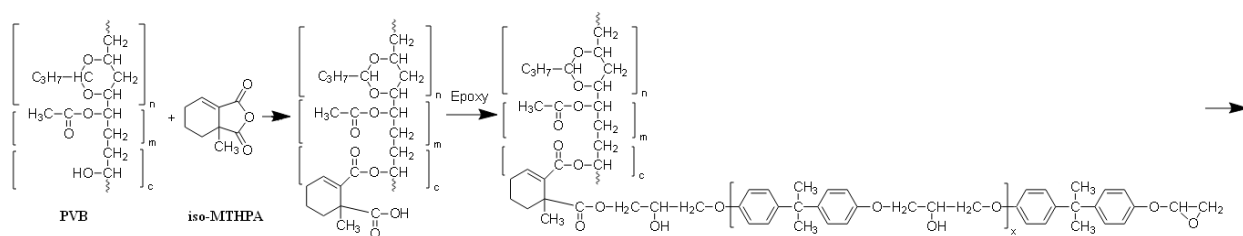
[bezrukov@ips.ac.ru](mailto:bezrukov@ips.ac.ru)

Epoxy binders are widely used as matrices for polymer composites (PCM) with a variety of reinforcing elements. However, the main disadvantage of epoxy binders and, consequently, PCM based on them, is low crack resistance and poor impact characteristics. To solve this problem, thermoplastics and highly dispersed nanofillers are used as modifiers for epoxy matrices. Despite the promise of this approach, homogeneous dispersion of fillers remains one of the main problems. The work [1] is devoted to this issue, as well as to the study of the properties of modified matrices. In addition, the presence of functional groups in the modifier can affect the speed and completeness of epoxy group reaction [2]. The purpose of this work is to investigate by FTIR spectroscopy the effect of a dispersed filler and a thermoplastic modifier capable of partial or complete dissolution in the epoxy oligomer-hardener system and of interaction with the hardener on the curing of the epoxy oligomer.

The binder based on epoxy oligomer DER-330 (Dow Chemical) was modified with a thermoplastic polymer - polyvinylbutyral (PVB) and disperse filler - organomodified montmorillonite Cloisite 30B. The hardener was isomethyltetrahydrophthalic anhydride. An IFS 66v/s vacuum spectrometer (Bruker) was used to record infrared (IR) spectra. The spectra of the initial substances and systems during curing were recorded in transmission mode while the samples were heated in the spectrometer thermal cell, recording spectra in the range of 4000-400  $\text{cm}^{-1}$  with a resolution of 1  $\text{cm}^{-1}$ .

The IR spectra of the uncured system with a combination of modifiers (PVB and Cloisite 30B) do not differ significantly from the data obtained for the system with only thermoplastic modifier (PVB). Organomodified montmorillonite is expected to form hydrogen bonds with the polar groups of the system; otherwise, its IR spectrum does not change. This fact demonstrates that a high-temperature pretreatment of the "binder-montmorillonite" mixture produces low-energy interactions between the mixture components, which can contribute to a uniform distribution of clay particles in the epoxy binder.

Analysis of the high-temperature spectra of the system indicates the participation of PVB in the curing of the epoxy oligomer and the formation of a three-dimensional network. In other words, the thermoplastic PVB is one of the components of the resulting network because it chemically interacts with the hardener, and the product of this interaction acts as an alternative component for curing the epoxy oligomer. Based on these results, we can conclude that, along with the standard curing reaction, there is an additional curing reaction of the epoxy oligomer (fig. 1).



**Figure 1.** Curing reaction of epoxy oligomer by anhydride hardener-PVB system

### References

- [1] Bezrukov N.P., Antonov S.V., Kostyuk A.V., Smirnova N.M. *Book of abstracts – 8th Bakeev Conference “Macromolecular Nanoobjects and Polymer Nanocomposites” (Moscow) 2020*, 43.  
[2] Ignatenko V.Y., Kostyuk A.V., Kostina J.V., Bakhtin D.S., Makarova V.V., Antonov S.V., Ilyin S.O. *Polymer Engineering & Science 2020*, 60, 7, 1530-1545.

## COLISTIN-POLYSACCHARIDE CONJUGATES

*Bokatyi A.N.*<sup>1,2</sup>, *Dubashynskaya N.V.*<sup>1</sup>, *Skorik Y.A.*<sup>1</sup>

<sup>1</sup>Institute of Macromolecular Compounds of the Russian Academy of Sciences, Saint Petersburg, Russia

<sup>2</sup>Saint Petersburg State University, Saint Petersburg, Russia

Student

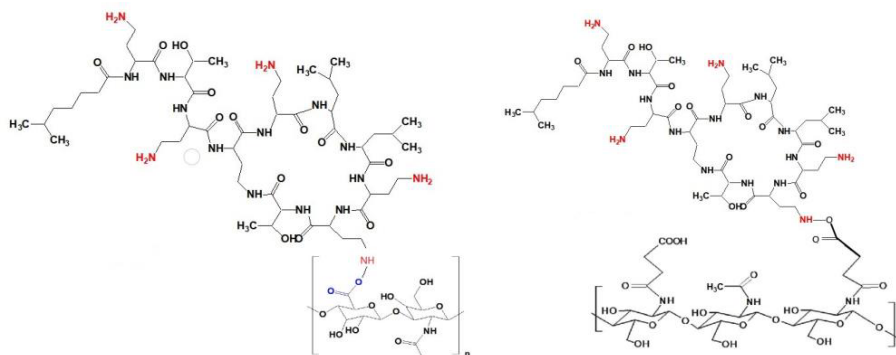
[st085508@student.spbu.ru](mailto:st085508@student.spbu.ru)

The emergence of multidrug-resistant gram-negative bacteria (the so-called ESKAPE pathogens: *Enterococcus faecium*, *Staphylococcus aureus*, *Klebsiella pneumoniae*, *Acinetobacter baumannii*, *Pseudomonas aeruginosa*, and *Enterobacter*) has led to the return to medical practice of well-known antibacterial drugs such as colistin sulfate (Col). Col has excellent therapeutic potential because it is effective against four of the six ESKAPE pathogens (*K. pneumoniae*, *A. baumannii*, *P. aeruginosa*, and *Enterobacter*). Col is a mixture of Col A and Col B decapeptides, which consist of a cyclic heptapeptide with a side chain acetylated at the end by a fatty acid. Col A and Col B differ in their fatty acids (6-methyloctanoic acid and 6-methylheptanoic acid, respectively). Currently, parenteral administration of Col is used in medicine to treat severe multidrug-resistant nosocomial infections, including nosocomial pneumonia and bacteremia. However, the medical use of Col is significantly limited (especially in pregnant women and children) because of its high nephrotoxicity and neurotoxicity [1]. One strategy for reducing the toxicity of drugs is chemical conjugation with various polymeric carriers, including natural polymers. The aims of this work were to develop a method for synthesizing of Col conjugates with polysaccharides – hyaluronic acid (HA) and succinyl chitosan (SucCS) [2] – and to study their antimicrobial activity.

Conjugates of Col-HA and Col-SucCS were prepared by carbodiimide activation with N-(3-dimethylaminopropyl)-N'-ethylcarbodiimide hydrochloride and N-hydroxysuccinimide, which led to the formation of amide bonds between the amino groups of Col and the carboxyl groups of HA or SucCS (Figure 1). Thus, four Col-HA conjugates and four Col-SucCS conjugates with varying degrees of grafting ranging from 3% to 10% were obtained. The conjugates were characterized by the degree of substitution by <sup>1</sup>H NMR spectroscopy on a Bruker Avance 400 MHz spectrometer, solvent D<sub>2</sub>O + trifluoroacetic acid (TFA).

The degree of substitution (DS) was calculated from the Col multiplet signal, located in the region of the strongest field and suggesting 18 Col protons. The base signal was the signal of the anomeric proton H-1 (for HA or SucCS) or the signal of the methyl protons of the acetamide group (for SucCS with a degree of acetylation of 26%, it is 0.78 H).

Preliminary data on the release of Col from conjugates showed that Col is not released into the sodium phosphate buffered saline medium (pH 7.4, 37 ° C). At the same time, the minimum inhibitory concentrations (MIC) of the conjugates in relation to *P. aeruginosa* (1 × 10<sup>7</sup> CFU / ml) did not change compared to the initial Col and amounted to 1 µg / ml for the HA-Col-10 and SucCS-Col-10, which indicates the preservation of the activity of the antibiotic in the conjugate.



**Figure 1.** Conjugates of HA-Col and SucCS-Col.

### References

[1] Dubashynskaya, N.V.; Skorik, Y.A. *Pharmaceuticals* **2020**, *13*, 83.

[2] Skorik Y.A., Kritchenkov A.S., Moskalenko Y.E., Golyshev A.A., Raik S.V., Whaley A.K, Vasina L.V., Sonin D.L. *Carbohydrate Polymers* **2017**, *166*, 166.

Acknowledgements. This work was financially supported by the Russian Science Foundation (project No 19-73-20157).

STRUCTURE-PHOTOOPTICAL PROPERTY RELATIONSHIPS IN LC POLYMETHACRYLATES WITH SIDE AZOBENZENE GROUPS: THE ROLE OF CHIRALITY, SPACER AND ALIPHATIC FRAGMENTS LENGTHS

*Boychuk A.<sup>1</sup>, Bobrovsky A.<sup>1</sup>, Shibaev V.<sup>1</sup>, Cigl M.<sup>2</sup>, Pomeisl K.<sup>2</sup>, Hamplová V.<sup>2</sup>, Bubnov A.<sup>2</sup>*

<sup>1</sup>Faculty of Chemistry, Moscow State University, 119991, Moscow, Russia

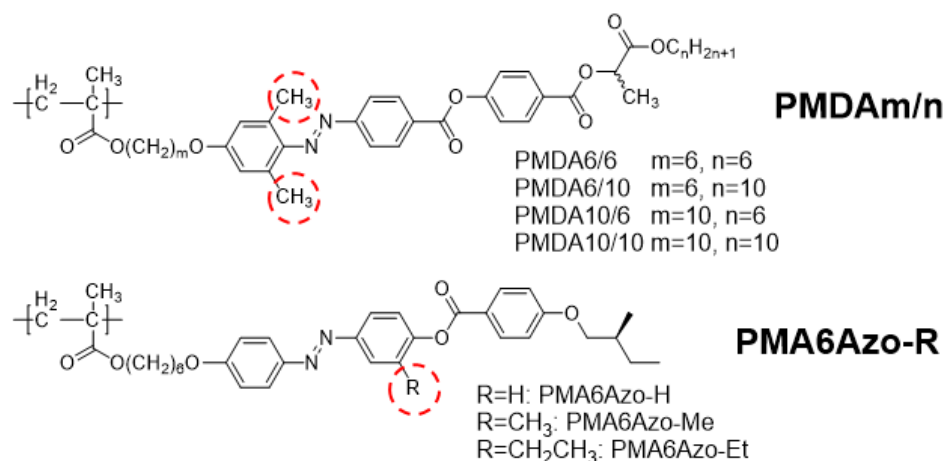
<sup>2</sup>Institute of Physics, The Czech Academy of Sciences, 182 21 Prague 8, Czech Republic

PhD student

artboi95@gmail.com

Photoorientation processes observed in azobenzene-containing polymers under polarized UV or visible light irradiation lead to an appearance of linear dichroism and birefringence in amorphous polymer films that could be used for the creation of materials for applications in photonics [1] and organic photovoltaics [2-3].

In the present work series of racemic and enantiopure **PMDAm/n** polymers (Fig.1) having lateral methyl substituents in photochrome were synthesized and characterized. For the first time, an influence the length of the spacer, the terminal chiral fragment, as well as the chirality on the photo-optical properties and phase behavior for polymers with laterally-substituted chromophores were established. In addition, an investigation of polymers **PMA6Azo-R** series (Fig.1) showed the effect of the lateral substituent length in the photochrome on the photo-optical properties and phase behavior of azobenzene-containing polymers.



**Figure 1.** Chemical structure of azobenzene-containing polymers of **PMDAm/n** and **PMA6Azo-R** series.

Comparing the differences in the phase behavior in **PMDAm/n**, **PMA6Azo-Me**, **PMA6Azo-Et** polymers, and their unsubstituted analogs, it can be concluded that lateral substituents decrease the anisotropy of mesogens; therefore, the range of the LC phase existence and the degree of the mesophase ordering decreases.

It is shown, that the maximum values of photoinduced dichroism depends on the spacer (m) and side substituent length (n). Investigations on the photoorientation process under polarized visible light action reveals that an increase in the spacer length leads to an increase in the value of photoinduced dichroism probably due to the enhancement in the side groups' molecular mobility (from 0.5 for **PMDA6/6** to 0.78 for **PMDA10/6-rac.**). However, increasing the length of side substituent reduces the degree of mesogen anisotropy, which results in a decrease in the values of maximum achievable photoinduced dichroism (from 0.89 for **PMA6Azo-H** to 0.25 for **PMA6Azo-Et**). The maximum achievable photoinduced dichroism does not depend on the chirality of the polymer sample, except polymers **PMDA10/10** and **PMDA10/10-rac.**, and is practically independent on the length of the terminal chiral group. Synthesized and studied polymers demonstrate promising photooptical properties suitable for the applications in photonics.

### References

- [1] Emoto A., Uchida E., Fukuda T. *Polymers (Basel)* **2012**, 4, 150–186.
- [2] Iwan A., Sikora A., Hamplová V., Bubnov A. *Liq. Cryst.* **2015**, 42, 964–972.
- [3] Bubnov A., Iwan A., Cigl M., Boharewicz B., Tazbir I., Wójcik K., Sikora A., Hamplová V. *RSC Adv.* **2016**, 6, 11577–11590.

Acknowledgements. This work was supported by the Russian Foundation for Basic Research (19-53-26007) and the Russian Science Foundation (19-13-00029).

# INVESTIGATION OF THE EFFECT OF CITRIC ACID ON THE PHYSICAL AND MECHANICAL PROPERTIES OF POLYIMIDE FOAMS

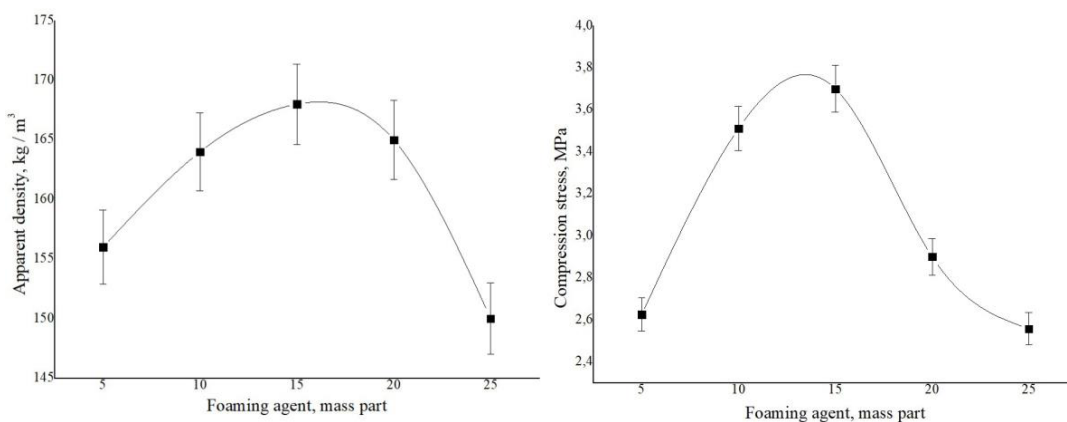
*Brunko P.D., Rodin A.S., Litosov G.E., Lavrov N.A.*

Saint-Petersburg State Technological Institute (Technical University), Faculty of Chemical and Biotechnology,  
Saint-Petersburg, Russia  
Student  
[pasha.brunko@mail.ru](mailto:pasha.brunko@mail.ru)

The influence of the gas-forming agent on the physical and mechanical properties of polypolyimides based on polyacrylamide of the PAA brand of the AK-642 series of the AP-9405 (molecular weight-1-2 million) was studied. Citric acid was used as a foaming agent, water was used as a solvent and steam plasticizer [1].

The apparent density ( $\rho$ , kg / m<sup>3</sup>) of the obtained foam polymers was determined according to ISO 845:2006. The breaking stress under compression ( $\sigma$ , MPa) was studied according to ISO 844:2014 on the universal breaking machine Shimadzu AG-X Plus 50 kN.

According to the graphs (Figure 1), it can be concluded that an increase in the concentration of the gas-forming agent in the compositions (up to 15 mass parts) increases the density and strength of the samples. With the introduction of more than 15 mass parts, a decrease in the physical and mechanical properties of foams is observed, due to the catalytic effect of acids on the intra-chain imidization, which leads to an increase in the frequency of crosslinking, which increases the rigidity of foams. With increasing rigidity, the foam material becomes brittle to external loads. Also, an increase in the rate of imidization leads to an intense release of ammonia, which destroys the cell films. As a result, the average size of the cells increases, and voids are formed. This factor reduces the dispersion, as a result of which polyacrylamides become more brittle.



**Figure 1.** Physical and mechanical properties of the obtained polyacrylamides.

## References

[1] Litosov G.E., Dvorko I.M., Lavrov N.A., Chistyakov N.A., Muravsky A.A. *Plast. Massy*. **2020**, 5-6, 25-28



# NAPHTHOQUINONE SERIES ANTICANCER DRUG DELIVERY SYSTEM BASED ON PCL BIODEGRADABLE POLYMERIC MATERIAL

*Danilenko N.V.*<sup>1</sup>, *Bolbasov E.N.*<sup>1</sup>, *Khlebnikov A.I.*<sup>1,2</sup>, *Schepetkin I.A.*<sup>3</sup>

<sup>1</sup>Tomsk Polytechnic University, Tomsk, Russia;

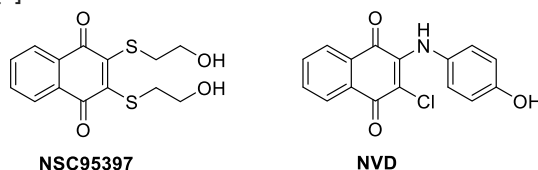
<sup>2</sup>Scientific Research Institute of Biological Medicine, Altai State University, Barnaul, Russia;

<sup>3</sup>Department of Microbiology and Immunology, Montana State University, Bozeman, USA;

Research engineer

nadezhda.dani@gmail.com

Naphthoquinone derivatives are promising compounds for the development of anticancer agents, since they can affect various signaling pathways in tumor cells [1]. One example of a naphthoquinone with multiple biological effects is NSC95397 (2,3-bis[(2-hydroxyethyl)thio]-1,4-naphthoquinone) (Figure 1), a mild inhibitor of protein kinase B (also known as Akt), I $\kappa$ B kinase  $\alpha/\beta$  (IKK  $\alpha/\beta$ ), TANK-binding kinase (TBK1) and mitogen-activated protein kinase 7 (MKK7) [2].



**Figure 1.** Structures of naphthoquinone derivatives with anticancer activity

After oncotomy, various problems arise, including cavity formation, in the place of which a cicatricial tissue is subsequently formed, and remaining cancer cells, which can provoke tumor growth again. The solution to these problems could be a biodegradable material filled with an anti-cancer drug that will eventually be replaced by native tissue. To achieve high integration, an ideal material should accurately imitate the morphology of the restored tissues [3]. Material, which is useful for this purpose could be fiber-based scaffolds produced from biodegradable polymer by electrospinning method and filled with anticancer drug. The aim of the present work was to obtain PCL-based scaffolds with various content of naphthoquinone derivative.

In our research we synthesized series of naphthoquinone derivatives and investigated *in vitro* their anticancer activity against the MonoMac6 monocytic leukemia tumor cell line. The most promising as an future anticancer drug was 2-chloro-3-((4-hydroxyphenyl)amino)-1,4-naphthoquinone (**NVD**) (Figure 1). IC<sub>50</sub> of compound **NVD** was 2.6  $\mu$ M, in compare IC<sub>50</sub> of compound NSC95397 was 4.2  $\pm$  0.9  $\mu$ M. Moreover, compound **NVD** was an inhibitor of MKK7, the binding constant K<sub>d</sub> was 2.1  $\pm$  0.4  $\mu$ M. Due to these results, we used this compound as model anti-cancer drug for scaffold filling.

Fibrous scaffolds based on poly( $\epsilon$ -caprolactone) containing compound **NVD** were obtained from 1,1,1,3,3,3-hexafluoro-2-propanol (HFIP) solution by electrospinning method. The content of compound **NVD** in the scaffolds was 0.01 mg/mL, 0.025 mg/mL, 0.05 mg/mL. SEM studies showed that scaffolds have a homogeneous structure, without visible defects and inclusions. The study of the obtained materials cytotoxicity on MonoMac6 cells has shown that scaffolds with a compound **NVD** content of 0.05 mg/mL have the highest cytotoxicity. Our result demonstrated that fiber-based scaffolds produced from PCL by electrospinning method have a good compatibility with naphthoquinone compounds and could be used as a delivery system for naphthoquinone series anticancer drugs.

## References

[1] *Bioorg. Med. Chem.*, **2013**, 21, 4662–4669

[2] *Biochem. Pharmacol.*, 2014, 88, 201–215

[3] *Biotechnol. Adv.*, **2013**, 31, 669–687

Acknowledgements. This work was supported by the Russian Science Foundation (project No17-15-01111)

# WATER PURIFICATION FROM PRIMARY MICROPLASTICS

*Didenko T.A.*

Omsk State University, Omsk, Russia  
PhD in Chemistry  
[tatiana.a.didenko@gmail.com](mailto:tatiana.a.didenko@gmail.com)

The mass production and use of plastic began in the middle of the 20th century, but already in the 1970s, the issue of plastic pollution was raised. In 2004, the term "microplastic" was first introduced as a characteristic of plastic pollution [1]. The presence of microplastics in aquatic environments is of great concern. Currently, microplastics are considered to be individual polymer particles ranging in size from a few nanometers to 5 mm [2].

In most cases, microplastics are secondary, i.e. are the product of the destruction of more massive plastic objects. However, there is also primary microplastic - small polymer particles for specific applications, including industrial cleaning products, as well as microbeads in body and face scrubs, shower gels and toothpastes [3]. This pathway of microplastics entering the environment is quite significant, therefore, for example, in the United States in 2015, a ban was introduced on the use of polyethylene microgranules [4]. Since the widespread use of cosmetics with primary microplastics in the composition leads to significant discharges into the aquatic environment through urban wastewater [5].

The aim of the work is to detect microplastic particles in the composition of cosmetics and to develop a method for purifying water from microplastic particles after using such products.

For the experiment, several cosmetics for various purposes were selected, containing microplastics according to the composition indicated on the label. After diluting the samples of cosmetics with distilled water, wet oxidation, filtration and drying, the separated dry residue was examined under an optical microscope. Most of the samples are close to spherical particles, potentially microplastics. These particles were collected manually from each obtained sample under the control of a microscope and analyzed using IR spectrometry. As a result of studies of this type, the presence of these polymer particles in the composition of the selected cosmetics was confirmed. These isolated samples contained polyethylene, polyethylene terephthalate, acrylate copolymer.

There are physical, chemical, biological and hybrid methods for cleaning the aquatic environment from microplastics [6]. The most accessible method is filtration through granular media, in particular sand, gravel, expanded clay. Another advantage of this method is also the high speed of the process. These factors determine the widespread use of this method of water purification in the world. We have proposed a method for purifying water from microplastic particles after using cosmetics with primary microplastics. This method is based on rapid sand filtration. This method allows you to achieve high degrees of purification, reaching 97-99%.

## References

- [1] Thompson R.C., Olsen Y., Mitchell R.P., Davis A., Rowland S.J., Jonh A.W.G., McGonigle D., Russel A.E. *Science* **2004**, 304, 838
- [2] Sobhani Z., Zhang X., Gibson C., Naidu R., Megharaj M., Fang C. *Water Res.* **2020**, 174, 115658
- [3] Auta H.S., Emenike C.U., Fauziah S.H. *Environ. Int.* **2017**, 102, 165–176
- [4] Striffling D.A. *J. Land Use Environ. Law* **2016**, 32, 151-162
- [5] Murphy F., Ewins C., Carbonnier F., Quinn B. *Environ. Sci. Technol.* **2016**, 50, 5800-5808
- [6] Hua K., Tiana W., Yanga Y., Nie G., Zhouc P., Wang Y., Duana X., Wanga S. *Water Res.* **2021**, 198, 117144

## DEVELOPMENT AND STUDY OF NOVEL MEMBRANES BASED ON POLYAMIDE MODIFIED WITH TITANIUM OXIDE FOR WATER TREATMENT

*Dmitrenko M.E.<sup>1</sup>, Kuzminova A.I.<sup>1</sup>, Zolotarev A.A.<sup>1</sup>, Penkova A.V.<sup>1</sup>*

<sup>1</sup>Saint Petersburg State University, Saint Petersburg, Russia  
[m.dmitrienko@spbu.ru](mailto:m.dmitrienko@spbu.ru)

Nowadays, photocatalytic membrane reactors with immobilized photocatalysts play an important role in intensification of industrial processes. They combine the activity of a photocatalyst and a membrane separation, which has great potential effectively to solve the problem of separating aggressive systems and recovering catalyst particles in water treatment. The relevance of the development of photocatalytic membrane reactors is due to concern for the environment. And also, the immobilization of the photocatalyst in the membrane allow avoiding the need for post-reduction of the photocatalyst and simultaneously overcoming membrane contamination associated with the photocatalyst and pollutants. In this work, the most widely-used aromatic polyamide (PA) due to its high permeability and titanium oxide were chosen as a membrane material and as a photocatalyst, respectively, for the development of high-performance filtration membranes with the prospect of application in photocatalytic membrane reactors.

The aim of this work was to develop high-performance membranes based on PA modified with titanium oxide and to study the effect of the photocatalyst (titanium oxide) on the membrane physicochemical properties and transport characteristics in ultrafiltration. Structure and physicochemical properties of the developed membranes were investigated by various analysis methods (SEM and AFM microscopies, the measurement of contact angle and the standard porosimetry method). Transport properties of the obtained membranes were evaluated in ultrafiltration of cutting fluid and model system of protein. It was demonstrated that the bulk modification of PA membranes with the titanium oxide particles led to a significant improvement of the membrane transport characteristics and antifouling stability due to significant changes in membrane structure.

**Acknowledgements.** The reported study was funded by RFBR, Sirius University of Science and Technology, JSC Russian Railways and Educational Fund "Talent and success", project number 20-38-51022. The experimental work of this study was facilitated by the equipment from the Resource Centre of Geomodel, Chemical Analysis and Materials Research Centre, Centre for X-ray Diffraction Methods, Magnetic Resonance Research Centre, Centre for Innovative Technologies of Composite Nanomaterials, Nanophotonics Centre, Cryogenic department, Thermogravimetric and Calorimetric Research Centre and the Interdisciplinary Resource Centre for Nanotechnology at the St. Petersburg State University.

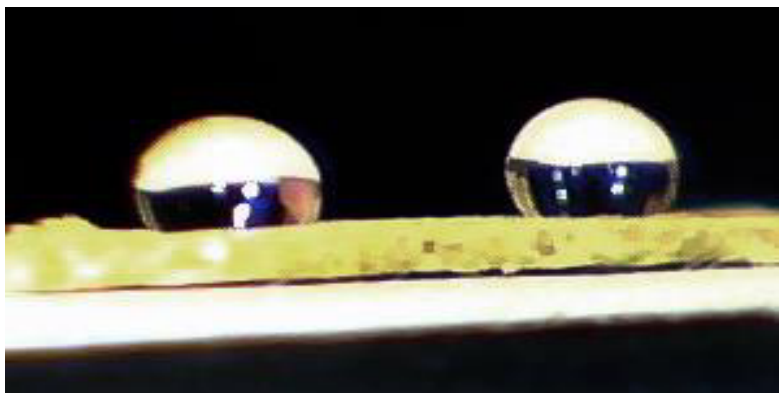
# PLATINUM AND RHODIUM CATALYZED HYDROSILYLATION AS MEANS TO SYNTHESIZE CELLULOSE-BASED GLYCOSILICONES

*Dobrynin M.V.<sup>1</sup>, Islamova R.M.<sup>1</sup>*

<sup>1</sup>Saint Petersburg State University, Saint Petersburg, Russia  
PhD student  
mikhail.dobrynin@student.spbu.ru

Hydrosilylation is a versatile reaction that allows attaching various functional groups and structural units to polysiloxanes. One of the most complicated tasks acquired by hydrosilylation is synthesis of glycosilicones – compounds that consist of hydrophobic polysiloxane and hydrophilic saccharide fragments [1]. The main difficulty lies in different solubilities as there is no common solvent for both reagents and therefore method for synthesis is nontrivial task [2]: one must introduce protection and deprotection steps what makes method more complicated or perform reaction heterogeneously, what usually leads to low conversion. The latter case can be compensated with effective reaction such as hydrosilylation.

In this work glycosilicones were synthesized from modified hydroxyethylcellulose and hydride-terminated polydimethylsiloxane via catalytic hydrosilylation. The reaction was performed using platinum (Karstedt's catalyst) or rhodium (Rh(acac)(CO)<sub>2</sub>) complexes heterogeneously without any preliminary protection steps for hydroxyethylcellulose. Structure of obtained glycosilicones was confirmed by <sup>1</sup>H, <sup>13</sup>C and <sup>29</sup>Si SS NMR and FTIR spectroscopy. Final products are less hydrophilic compared to original hydroxyethylcellulose: contact angles increased from 30 to 103–131° and enthalpy of mixing changed from –30 to –(5–15) J/g. Glycosilicones are insoluble in water, but swell in DMSO, CHCl<sub>3</sub> and CH<sub>2</sub>Cl<sub>2</sub>. Toxicity tests indicated that glycosilicones obtained via hydrosilylation are less toxic than one obtained with copper catalyzed azide-alkyne cycloaddition.



**Figure 1.** Contact angle measurement for obtained glycosilicones

## References

- [1] S. Boileau, B. Boury, F. Ganachaud, *Silicon Based Polymers*, Springer Netherlands, **2008**. DOI: 10.1007/978-1-4020-8528-4.  
[2] M.V. Dobrynin, V.Y. Kukushkin, R.M. Islamova, *Carbohydr. Polym.*, **2020**, 241, 116327. DOI: 10.1016/j.carbpol.2020.116327

Acknowledgements. This work was supported by the Russian Foundation for Basic Research (project No 19-33-90130).

Measurements were performed at Center for Magnetic Resonance, Center for Chemical Analysis and Materials Research, Thermogravimetric and Calorimetric Research Centre, Centre for Culture Collection of Microorganisms, Centre for Innovative Technologies of Composite Nanomaterials.

# ON THE APPLICABILITY OF ELECTROPHORESIS FOR PROTEIN QUANTIFICATION IN PRODUCTS OF MECHANICAL PROCESSING

*Dome K.V.<sup>1,2</sup>, Akimenko Z.A.<sup>2</sup>, Bechkov A.L.<sup>2</sup>*

<sup>1</sup>Novosibirsk State University, Novosibirsk, Russia

<sup>2</sup>Institute of Solid State Chemistry and Mechanochemistry SB RAS, Novosibirsk, Russia

Student

domekarina@ya.ru

Protein chemistry methods are currently used to control, optimize, and elaborate novel technologies in molecular biology, pharmacology, bioengineering, and food technology [1]. The method of polyacrylamide gel electrophoresis with the use of sodium dodecyl sulfate (SDS) as a detergent is widely used for objects of study containing proteins [2]. The intensity of stained bands in gel depends on the amount of the applied sample; i.e., it is assessed according to the laws of colorimetric measurements: staining intensity is directly proportional to protein content. Electrophoregrams are illustrative and informative. However, this technique is most typically used as a qualitative method and quite rarely as a semi-quantitative test (only visual assessment of band staining intensity is performed). In quantification assay, electrophoretic separation is used together with enzyme-linked immunosorbent assay or western blotting, which require respective immune sera against the target proteins.

This study makes a methodological attempt to use electrophoresis for protein quantification. The specially designed test bench for digital imaging of gels and optimally selected software allows one to quickly and easily determine the molecular weight distribution of protein molecules in the samples and perform quantitative assay. This will enable quality control of protein products according to the quantitative contents of fractions of protein molecules and presence of impurities.

Mechanical treatment of inorganic and organic compounds is one of the promising physical methods for changing properties, in which reagents of a biological and chemical nature are not used, and products of side reactions are practically not formed. Also, mechanical processing has shown its effectiveness in the processing of plant materials: the products of processing had a higher specific surface area and, as a consequence, reactivity [3]. However, mechanical treatment is an extremely energy-intensive process, therefore, to determine its effectiveness, it is necessary to take into account the amount of energy expended. Mechanical processing was carried out on a laboratory planetary mill AGO-2 (20 g), equipped with water cooling. The exposure time varied from 0 to 30 minutes. To evaluate the efficiency of the applied technology of mechanical processing of the model protein, the energy expended in the experiment was recorded using a high-speed wattmeter.

The resulting samples were prepared and analyzed by polyacrylamide gel electrophoresis. In this work we used photography to fix our results. In this work we used photography to fix our results. The grey-tone photo images of polyacrylamide gels with stained protein bands were used for protein quantification. Mathematical data processing was performed using the MultiChrom Planar software in order to obtain a dependence between protein concentration and band color intensity/peak area [4]. The results of quantitative measurements were processed and saved using the MultiChrom Planar software.

The findings have proved that this algorithm can be applied to process the electrophoretic data. The relative inaccuracy of the method was estimated using calibration solutions. To make protein quantification more accurate, it was suggested to use calibration solutions together with test samples so that all the variable factors during the analysis and recording the results could be taken into account.

Protein-containing substances, BSA (as a model protein) and casein within sports nutrition product, were subjected to mechanical treatment. The proposed method was used to obtain the data on dependence between the degradation degree of protein molecules and duration of mechanical treatment. Mechanical treatment of BSA for 30 min caused degradation of protein molecules by  $92 \pm 3\%$ , while protein molecules within sports nutrition product were degraded by  $85 \pm 2\%$ . The degree of destruction of individual protein was higher compared to that of protein-containing mixture after mechanical treatment for an identical amount of time. The methodological approach used in this study can serve as guidance for other researchers who would like to use electrophoresis for protein quantification both in individual form and in protein mixtures. Also a relationship was established between energy costs and the degree of protein destruction.

## References

- [1] Nice E.C. *Biomedical Chromatography* **2021**, 35, 915
- [2] De Silva Neto G.F, de Andrade Rodrigues M.L., Fonseca A. *Talanta* **2021**, 221, # 121602
- [3] Gavrilova K.V., Bychkov A.L., Bychkova E.S., Akimenko Z.A., Chernonosov A.A., Kalambet Ju.A., Lomovskii O.I. *Food and Raw Materials* **2019**, 7, 255
- [4] Mikhailova K., Krasilov V., Malahova I., Kozmin Y., Kalambet Y. *Analytics* **2014**, 19, 56

Acknowledgements. The research was funded within the state assignment to ISSCM SB RAS (project No FWUS-2021-0005). Determination of energy consumption was carried out with the support of the Russian Science Foundation (project No 19-73-10074).

# ETHANOL DEHYDRATION BY EXTRACTIVE DISTILLATION WITH AMINOETHERS OF BORIC ACID

Dulmaev S.E., Davletbaeva A.R., Klinov A.V., Malygin A.V., Davletbaeva I.M.

Kazan National Research Technological University, Kazan, Russia  
 PhD Student  
[impsble@gmail.com](mailto:impsble@gmail.com)

Aminoethers of boric acid (AEBA) were synthesized by using boric acid, triethanolamine and triethylene glycol (AEBA-TEG) / diethylene glycol (AEBA-DEG). Due to formation of intermolecular complexes with the participation of borates, the structure of aminoethers of boric acid contains separated in space ion pairs [1], which give these compounds the properties inherent in ionic liquids. The effect of the glycol length of components on the thermal-oxidative stability of organoboron ionic liquids has been studied. It was shown that resistance to thermal oxidative degradation of samples decreases with decreasing size of the glycol component. According to the results of studies carried out using high-speed scanning calorimetry, measurements of density, dynamic viscosity and electrical conductivity, it was found. that water is involved in the structural organization of AEBA.

The influence of the most thermally stable AEBA on the conditions of phase equilibrium of a vapor-liquid azeotropic ethanol / water mixture was investigated. It is shown that in the separated mixture the coefficient of the relative volatility of ethanol increases with an increase in the concentration of aminoethers, including in the region close to the azeotropic point (Table). The magnitude of this effect is at the level shown for ionic liquids based on imidazole [2], which provide high selectivity for the separation of aqueous-alcoholic solutions. The advantages of using aminoethers of boric acid obtained on the basis of diethylene glycol (AEBA-DEG) and triethylene glycol (AEBA-TEG) in the extractive distillation of water-alcohol mixtures are shown.

**Table.** Relative volatility coefficient of ethanol at different contents aminoethers of boric acid.

$W^{AEBA}$	The range of compositions of the liquid phase for ethanol	$\alpha_{12}(AEBA-TEG)$	$\alpha_{12}(AEBA-DEG)$
0.25	0.84-0.87	1.95	1.65
0.30	0.82-0.85	2.21	1.80
0.40	0.78-0.86	2.89	2.05
0.50	0.64-0.81	3.37	2.50
0.60	0.53-0.83	4,17	4.50
0.70	0.37-0.77	4.50	4.95
0.75	0.59-0.73	5.04	5.68

## References

- [1] Davletbaeva I.M., Dulmaev S.E., Sazonov O.O., Klinov A.V., Davletbaev R.S., Gumerov A.M. *RSC Adv.* **2019**, 9(41), 23535-23544.  
 [2] Ge Y., Zhang L., Yuan X., Geng W., Ji J. *J. Chem. Thermodyn.* **2008**, 40(8), 1248-1252.

Acknowledgements. This work was supported by the Russian Science Foundation (grant no. 19-19-00136)

## AMPHIPHILIC GLYCOPOLYPEPTIDES AS POTENTIAL DRUG/GENE DELIVERY SYSTEMS

*Dzhuzha A.U.<sup>1</sup>, Korzhikova-Vlakh E.G.<sup>1,2</sup>*

<sup>1</sup> Saint Petersburg State University, Saint Petersburg, Russia

<sup>2</sup> Institute of Macromolecular Compounds Russian Academy of Sciences, St. Petersburg, Russia  
PhD student

[polinadzuzha@mail.ru](mailto:polinadzuzha@mail.ru)

Nowadays there is a continuing need for the development of novel drug carriers which enables efficient and targeted therapy. Numerous polymer materials such as polyethyleneimine, polylysine, polyarginine, chitosan as well as cationic liposomes and dendrimers have been tested for this application. However, some of their properties, such as non-degradability of polyethyleneimine, toxicity of polylysine and polyarginine, instability of cationic liposomes limit their applicability. Synthetic glycopolypeptides are a class of polymers that have significant promise for being a constituent of a modern drug/gene delivery system due to their biodegradability, biocompatibility, ease of modification and others. Coupling carbohydrate units to side chains can bring about not only higher biocompatibility of polymers, as well as decrease the uptake by macrophages and may serve as a vector for targeted delivery to cancer cells due to its specifically binding to receptors over-expressed on many cancer cells [1, 2].

Generally, amphiphilic polymers can self-assemble in aqueous solutions over the critical micelle concentration to form structures of various morphology enabling encapsulation of drug substances into it. Recently, in the Laboratory of Biomedical Chemistry of Institute of Chemistry SPbU the oligonucleotides (siRNA) delivery systems based on amphiphilic terpolymers of lysine, glutamic acid and phenylalanine/isoleucine have been developed and the efficiency for VEGF RNA interference by encapsulated into polypeptide nanoparticles siRNA was established [3].

In this work a set of glycopolypeptides consisted of glutamic acid, modified with histidine, tryptophan and N-glucosamine taken in different ratio was obtained. The main polypeptide chain was synthesized by ring-opening polymerization of  $\gamma$ -benzyl-glutamate N-carboxyanhydride (NCA). Further modifications of polypeptide chain were carried out using post-polymerization strategy. <sup>1</sup>H-NMR, DLS, ELS and TEM were applied to characterize obtained polymers. Prepared from synthesized glycopolypeptides nanoparticles were studied in terms of their stability, encapsulation efficiency, cytotoxicity and are supposed to be testified as drug (Paclitaxel) and gene (siRNA) delivery systems.

### References

- [1] Zhao Wang *et al.* *Advances in Polymer Technology* **2020**, 2020, 1-16
- [2] Kai-Steffen Krannig and Helmut Schlaad *Soft Matter* **2014**, 10, 4228
- [3] Olga Osipova *et al.* *Pharmaceutics* **2020**, 12(1), 39

Acknowledgements. This work was supported by Russian Science Foundation (project №21-73-20104).



# EVALUATION OF THE APPLICABILITY OF POLYMER MICELLAR PROBES BEARING NEAR-INFRARED IRIIDIUM(III) COMPLEX FOR LIFETIME OXYGEN BIOSENSING

*Elistratova A.A., Chelushkin P.S., Kritchenkov I.S., Solomatina A.I., Tunik S.P.*

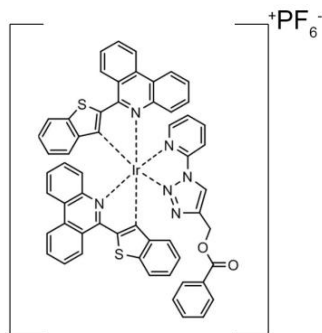
Saint Petersburg State University, Saint Petersburg, Russia  
Student  
anastasia0905@yandex.ru

Molecular oxygen is of paramount importance for the functioning of aerobic cells. Measuring oxygen concentration gradients within cells can help to deepen knowledge about cellular growth and metabolism, and to study in more detail the pathological processes characterized by cellular hypoxia, for example, the growth of cancer. To date, the most reliable oxygen biosensing method is based on measuring the excited state lifetime of a phosphorescent probe (Phosphorescence Lifetime Imaging, PLIM). However, the design of a probe that meets the strict requirements for intracellular oxygen biosensing is a challenging task.

PLIM probes are commonly based on transition metal complexes (TMC), the phosphorescence of which is extremely sensitive to the presence of oxygen. However, TMCs have two significant drawbacks: as a rule they are insoluble in water and their lifetimes are also sensitive towards biological microenvironment. Therefore, encapsulation of the chromophore into a biocompatible nanocarrier is rational way to solve the above mentioned problems. The central hypothesis of the research is that polymer micelles as a carrier can simultaneously provide dispersion stability for phosphorescent transition metal complexes in aqueous media and protect them from the interaction with microenvironment. Thus, this work is devoted to assessing the applicability of PLIM probes encapsulated into block copolymer micelles. We also compared the properties of the micellar probes with those based on the adducts of iridium complexes with human serum albumin (HSA) [1].

In this study, we have evaluated HSA adducts and block copolymer micelles based on either poly(dimethylsiloxane)-block-poly(ethylene glycol) (PDMS<sub>15</sub>-b-PEG<sub>110</sub>) or poly(caprolactone)-block-poly(ethylene glycol) (PCL<sub>45</sub>-b-PEG<sub>110</sub>) loaded by the iridium (III) complex **Ir1** of [(N<sup>^</sup>C)<sub>2</sub>Ir(N<sup>^</sup>N)]<sup>+</sup> type (Figure 1). The size of the obtained particles was evaluated by the dynamic light scattering. Photophysical properties of the obtained probes were studied including measuring the excited state lifetimes in aerated and degassed solutions. Finally, we evaluated the applicability of the probes for PLIM experiments on monolayers of Chinese hamster cells (CHO-K1).

All the investigated probes were found to be small in size (< 20 nm) and thus were easily taken up by cells. But only **Ir1**@PCL<sub>45</sub>-b-PEG<sub>110</sub> has demonstrated satisfactory lifetime insensitivity to microenvironment composition, the crucial property for the development of an efficient oxygen probe.



**Figure 1.** Chemical structure of complex **Ir1**

It is our hope that the work will be the beginning of the first systematic study of a new class of oxygen sensors based on block copolymer micelles and will help better understanding of the behavior of luminescent labels in the micellar core matrix.

## References

[1] Kritchenkov, I. S., Chelushkin, P. S., Sokolov, V. V., Pavlovskiy, V. V., Porsev, V. V., Evarestov, R. A., Tunik, S. P., *Organometallics*, **2019**, *38*(19), 3740-3751.

**Acknowledgements.** This work was supported by the Russian Foundation for Basic Research (project № 20-53-S52001). The work was performed using the equipment of St. Petersburg State University Research Park: Center for Magnetic Resonance, Center for Optical and Laser Research, Center for Chemical Analysis and

Materials Research, Centre for Diagnostics of Functional Materials for Medicine, Pharmacology and Nanoelectronics.

NEW METHOD FOR PREPARATION OF LADDER-LIKE POLYPHENYLSILSESQUIOXANES –  
CONDENSATION OF PHENYLCONTAINING SILOXANOLS IN AMMONIA

*Ershova T.O.*<sup>1</sup>, *Anisimov A.A.*<sup>1</sup>, *Nikiforova G.G.*<sup>1</sup>, *Buzin M.I.*<sup>1</sup>, *Shchegolikhina O.I.*<sup>1</sup> and *Muzafarov A.M.*<sup>1,2</sup>

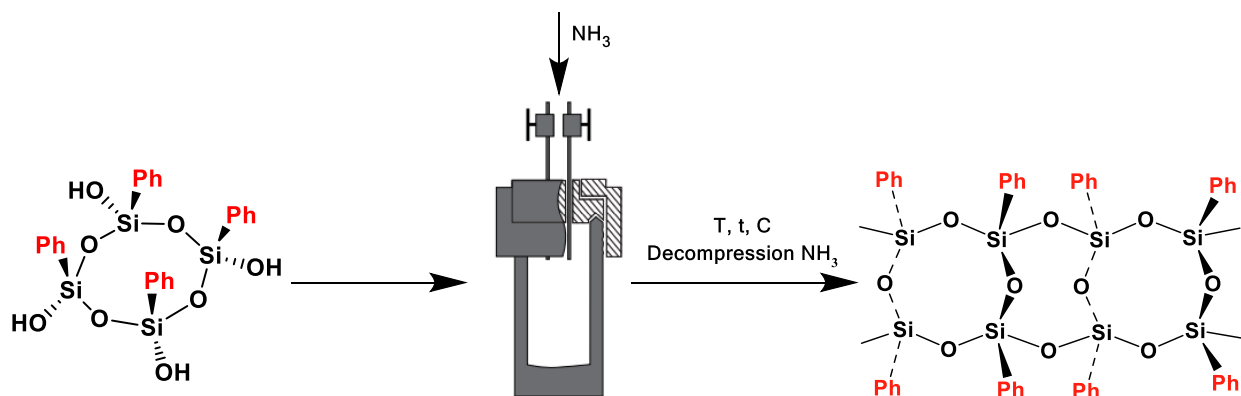
<sup>1</sup> A. N. Nesmeyanov Institute of Organoelement Compounds, Russian Academy of Sciences, Moscow, Russia

<sup>2</sup> N. S. Enikolopov Institute of Synthetic Polymeric Materials, Russian Academy of Sciences, Moscow, Russia  
[ershovatatyana\\_2995@mail.ru](mailto:ershovatatyana_2995@mail.ru)

Polyphenylsilsesquioxanes are an important class of organosilicon compounds with a number of valuable physicochemical properties that allow them to be used as heat-resistant and protective coatings, materials with a high refractive index and radiation resistance. However, the synthesis of these compounds requires a reaction under harsh conditions using various organic solvents and catalysts. Therefore, the search for simple and effective methods for the preparation of such polymers seems to be urgent.

Our group is developing a new and convenient method for the synthesis of various organosilicon oligomers and polymers by reacting in ammonia, which acts both as a solvent and as a catalyst for the condensation process. The main advantages of using ammonia as a synthesis medium are the possibility of varying their properties by changing temperature and pressure, as well as the instantaneous removal of the medium from the reaction zone during decompression. What is also important is that the gas used in this case does not require purification after the end of the reaction and can be reused for subsequent syntheses.

This paper will present our research in the field of condensation of phenyl-containing silanols and siloxanols, such as  $\text{Ph}_3\text{Si}(\text{OH})$ ,  $\text{Ph}_2\text{Si}(\text{OH})_2$ ,  $\text{PhSi}(\text{OH})_3$ , *cis*- $[\text{PhSi}(\text{O})\text{OH}]_4$  (*cis*-tetrol) in ammonia. Using *cis*-tetrol as an example, the effect of monomer concentration, duration of synthesis, temperature, residual silanol groups, and water concentration in the system on the structure of the resulting polymers was studied (Figure 1). As a result, the optimal conditions for the reaction of formation of soluble high-molecular ladder polyphenylsilsesquioxanes were determined.



**Figure 1.** General scheme of condensation of *cis*-tetrol in ammonia

The obtained polymers were characterized by a complex of physicochemical methods of analysis:  $^1\text{H}$ ,  $^{29}\text{Si}$  NMR, IR spectroscopy, GPC, TGA, DSC and viscometry in solution. The mechanical properties of ladder polyphenylsilsesquioxanes of various molecular weights were also studied.

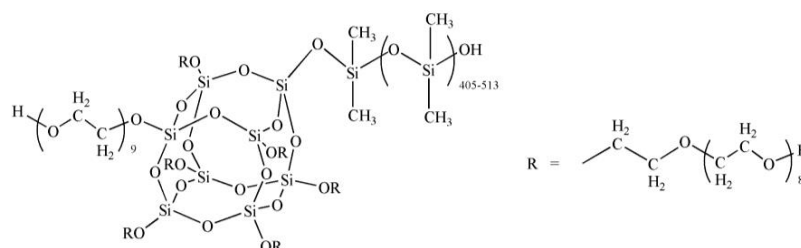
Acknowledgements. This work was supported by RFBR, (project № 19-03-00692).

## MODIFICATION OF HETEROGENEOUS-CHAIN POLYMERS WITH ORGANOSUBSTITUTED SILICA DERIVATIVES

*Faizulina Z.Z., Mukhamatgaleeva A.I., Izmailov S.R., Davletbaeva I.M.*

Kazan National Research Technological University, Kazan, Russia  
Postgraduate student, profile «Technology and processing of polymers and composites»  
[faizulina.alin@yandex.ru](mailto:faizulina.alin@yandex.ru)

Amphiphilic branched silica derivatives associated with an oligomeric medium were obtained using tetraethoxysilane, polyoxyethylene glycol and low molecular weight polydimethylsiloxane (ASiP) (**Figure**). The creation of an octahedral silica core was based on the hydrolysis and condensation reactions of tetraethoxysilane using water and a catalyst. The distinctive features of the structure and properties of amphiphilic silica derivatives synthesized using acidic and alkaline catalysts were established. It has been shown that the formation of silica particles occurs by the complexation of  $\text{CuCl}_2$  and polyoxyethylene glycol branches using  $\text{CuCl}_2$  as an acid catalyst.



**Figure.** Scheme of ASiP synthesis

IR, UV, NMR spectroscopy, dynamic light scattering and surface tension measurements allowed to establish the structure of ASiP. Using scanning electron microscopy, the particle size was determined to be 20-70 nm. Also it was found that the particles are the same size and have a spherical shape.

Dependences of kinematic and reduced viscosity for polydimethylsiloxanes obtained using ASiP were studied. It was shown that, an increase the reduced viscosity of polydimethylsiloxanes modified by ASiP occurs due to the involvement of amphiphilic branched silica derivatives associated with the oligomeric medium in the formation of intermolecular interactions between polydimethylsiloxane chains [1,2].

It has been established that the use of ASiP has a significant effect on the kinetics of octamethylcyclotetrasiloxane anionic polymerization, on the enhancement of intermolecular interactions of resulting polydimethylsiloxanes, on their molecular weight characteristics and on the physicomechanical properties of based on composite materials [3].

### References

- [1] Sheiko S.S., Prokhorova S.A., Beers K.L., Matyjaszewski K., Potemkin I.I., Khokhlov A.R., Möller M. *Macromolecules*. **2001**, *34*, 8354–8360.
- [2] Davletbaev, R.S., Zaripov I.I., Faizulina Z.Z., Davletbaeva I.M., Domrachova D.S., Gumerov A.M. *RSC Adv*. **2019**, *9*, 21233–21242.
- [3] Faizulina Z.Z., Davletbaev R.S., Zaripov I.I., Iskhakov A.F., Davletbaeva I.M. MODERN PROBLEMS OF POLYMER SCIENCE 15 th International Saint Petersburg Conference of Young Scientists October 28 – 31. Institute of Macromolecular Compounds of the Russian Academy of Sciences Saint Petersburg, **2019**. P.77.

Acknowledgements. This work was supported by Russian Foundation for Basic Research (project No 20-33-51001).

MICROSTRUCTURE OF COPOLYMERS OBTAINED IN THE PRESENCE  
OF CYCLOPENTADIENYL AND CARBONYL IRON COMPLEXES

Galimullin R.R., Kolesov S.V.

*Post-graduate student*  
*Ufa Institute of Chemistry UFRS RAS, Ufa, Russia*  
*Post-graduate student*  
*galimullin.ruslan2011@yandex.ru*

It was previously shown that metal complexes, including metallocenes (MC), as previously shown [1], have a significant effect on the process of radically initiated copolymerization of methyl methacrylate (MMA) and styrene (St). The presence of MC in the composition of the initiating system affected the composition and molecular weights of the copolymers, in comparison with the copolymers obtained by initiation only with of benzoyl peroxide (PB). This was explained by the formation in the process of two types of active centers: radical and coordination [2-3]. In this work, we studied the effect of iron complex (IC) – PB systems on the microstructure of copolymers of MMA and acrylonitrile (AN), MMA and St. The study used the following iron complexes: ferrocene (FC) and tricarbonyl cyclooctatetraene iron (TCI).

Were determined from the NMR spectra of the triad of copolymers MMA-AN and MMA-St. It should be noted that there is a noticeable effect of the composition of the comonomer mixture on the distribution of sequences in the copolymers MMA-AN and MMA-St. In copolymers MMA-AN, the content of sequences of homotriads of methyl methacrylate and acrylonitrile units in the samples obtained in the presence of IC-PB systems is higher than in the case of samples that were obtained by free radical copolymerization. The introduction of IC in the polymerization system leads to insignificant changes in the proportion of alternating triads. For copolymers MMA-St, similar changes are observed, namely, in the presence of IC, the content of methyl methacrylate centered homotriads is higher than in the case of free radical copolymerization. And the content of alternating triads with styrene units with the introduction of IC into the polymerization system is lower.

Thus, the introduction of IC in the composition of the initiating system has influence effect on the formation of homo- and alternating triads in the copolymers MMA-AN and MMA-St. Apparently, this is due to the fact that in the process of copolymerization, as in the case of homopolymerization [2,3], two types of active centers are involved: free radical and coordination. In this case, depending on the nature of the monomer, in the presence of IC, two types of coordination centers can be formed. We can assume that in the process of copolymerization of vinyl monomers in the presence of IC-PB systems, on each type of active center, predominantly occurs the coordination growth of its monomer.

#### References

- [1]. Yumagulova R.Kh., Kolesov S.V., Monakov Yu.B. *Russ. J. Appl. Chem.*, **2005**, 78, 291-294.
- [2]. Friesen A.K., Ulitin N.V., Khursan S.L., Shiyan D.A., Tereshchenko K.A., Kolesov S.V. *Mendeleev Commun.*, **2017**, 27, 374-376.
- [3] Ulitin N.V., Tereshchenko K.A., Friesen A.K., Shiyan D.A., Takhautdinova A.V., Kolesov S.V., Khursan S.L. *Int. J. Chem. Kinet.*, **2018**, 50, 742-756.

The reported study was funded by RFBR, project number 19-33-90095.

# SYNTHESIS OF CONJUGATES OF DEXAMETHASONE WITH SYNTHETIC POLYPEPTIDE

*Gladnev S.V.<sup>1</sup>, Zashikhina N.N.<sup>1,2</sup>, Korzhikova-Vlakh E.G.<sup>1,2</sup>.*

<sup>1</sup>Saint Petersburg State University, Saint Petersburg, Russia

<sup>2</sup>Institute of Macromolecules Compounds, Russian Academy of Sciences, Saint Petersburg, Russia

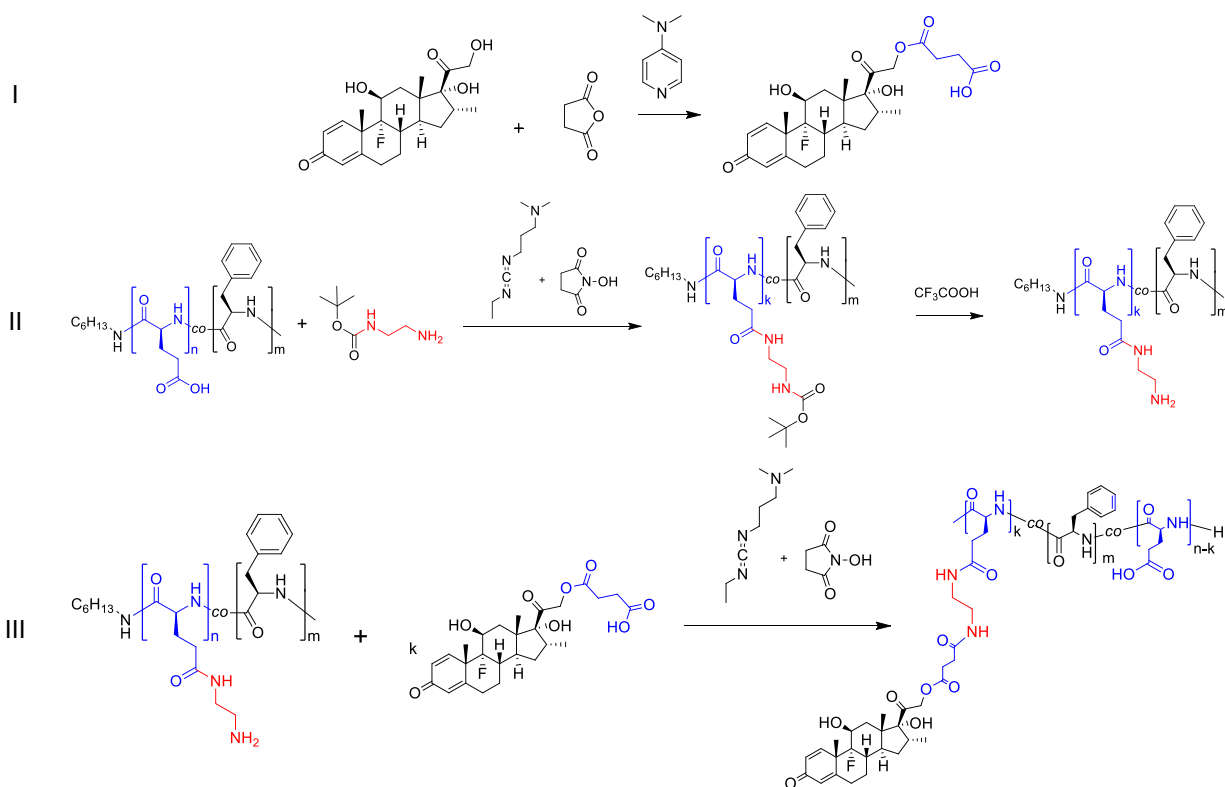
Student

[sergeyglad1920@mail.ru](mailto:sergeyglad1920@mail.ru)

Dexamethasone (DEX) is one of the most prescribed glucocorticoids. It is effective and safe in the treatment of a wide variety of ocular conditions, including anterior and posterior segment inflammation. However, its intravitreal half-life is very short, which means that it typically requires frequent administrations. An effective treatment with dexamethasone needs to achieve and maintain therapeutic concentrations in the target site.

In this work we developed the novel dexamethasone delivery systems in an attempt to achieve sustained release. When systems are designed for the posterior segment, biocompatibility, biodegradability and the ability to maintain adequate drug concentrations for prolonged period of time are crucial aspects. For this reason, polypeptides were selected as nanocarriers.

The synthesis of DEX conjugate with polypeptide poly(L-glutamic acid-co-D-phenylalanine) (P(Glu-co-DPhe)) includes 3 steps (Figure 1). At the first stage, dexamethasone-21-hemisuccinate was obtained by the reaction of dexamethasone with succinic anhydride in the presence of 4-dimethylaminopyridine (I). At the second stage, the polymer carboxyl groups were activated, followed by the reaction of the activated ester with a linker, namely (N-Boc-protected-ethylenediamine), containing one free amino group and one protected amino group. Then, the Boc-protecting group was removed using trifluoroacetic acid (II). At final stage, the formed polymer was covalently bound with dexamethasone hemisuccinate by the method of activated esters (III).



**Figure 1.** Synthesis of conjugates of dexamethasone with synthetic polypeptide P(Glu-co-DPhe)

The structures of synthesized substances were confirmed by <sup>1</sup>H NMR spectroscopy. The amount of bound DEX was calculated using HPLC analysis of the sample after conjugate alkaline hydrolysis. The dexamethasone content was 30 µg/mg of copolymer.

**Acknowledgements.** This work was supported by the Russian Ministry of Education and Science within State Contract 14.W03.31.0025 (Megagrant).

## CONTROLLED SYNTHESIS AND AGGREGATION BEHAVIOUR OF FLUOROCONTAINING AMPHIPHILIC COPOLYMERS

*Grigoreva A.O.<sup>1</sup>, Tarankova K.A.<sup>1</sup>, Zaitsev S.D.<sup>1</sup>*

<sup>1</sup>Lobachevsky State University of Nizhni Novgorod, Nizhni Novgorod, Russia  
PhD student  
alex.grigoreva@gmail.com

The connection of polymer science with material science requests the synthesis of different polymer structures in order to produce material with novel properties. RAFT polymerization is a versatile and powerful tool to contribute to the development of various polymer architectures [1]. Among them of prime interest are the amphiphilic copolymers. Fluorine-containing units of the macromolecular chain are attractive as a hydrophobic moiety of amphiphilic copolymers [2]. The distribution of hydrophilic and hydrophobic parts of macromolecules determines properties of amphiphilic compounds.

This research deals with the effect of the structure of fluoro(meth)acrylates on the kinetic features of their RAFT (co)polymerization. Besides, the effects of composition and microstructure of copolymers, pH and ionic strength of the subphase on isotherm curves and the surface properties of monomolecular films are considered.

Initially, the features of polymerization of 2,2,3,3,4,4,5,5-octafluoropentyl acrylate (OFPA) and 1,1,1,3,3,3-hexafluoroisopropyl acrylate (HFIPA) in the presence of S,S-dibenzyl trithiocarbonate (BTC) as chain transfer agent, as well as polymerization of 2,2,3,3-tetrafluoropropyl methacrylate (TFPMA) in the presence of 2-cyano-2-propyldodecyl trithiocarbonate and 4-cyano-4-[(dodecylsulfanylthiocarbonyl)sulfanyl]pentanoic acid were investigated. The values of the chain transfer coefficient were determined. The connection of synthesis conditions with structure of polymer was established. The structure of the obtained polymers was confirmed by the MALDI-TOF MS.

OFPA and HFIPA were copolymerized with acrylic acid and tert-butyl acrylate in the presence of low and high molecular RAFT agents. The conditions of forming statistical and gradient copolymers were shown, narrowly dispersed amphiphilic block copolymers OFPA, HFIPA and TFPMA with different nature of hydrophilic moiety were synthesized.

The behaviour of the obtained amphiphilic copolymers with various microstructures at the air/water interface was studied by Langmuir monolayer technique. The presence of supramolecular structures in monomolecular films was confirmed by atomic force microscopy.

### References

- [1] Barner-Kowollik C. Handbook of RAFT Polymerization. WILEY-VCH, 2008
- [2] Bruno A. Macromolecules. 2010, 43, 10163–10184

Acknowledgements. This work was supported by the Russian Foundation for Basic Research (Project №19-03-00843).

# INCREASING STABILITY AND PERFORMANCE OF NUCLEIC ACIDS VIA ENCAPSULATION INTO POLYELECTROLYTE COMPLEXES

*Gubina N.V.<sup>1</sup>, Khazanova M.A.<sup>1</sup>, Korzhikov-Vlakh V.A.<sup>1</sup>*

<sup>1</sup>Saint Petersburg State University, Saint Petersburg, Russia  
Student  
[st068855@student.spbu.ru](mailto:st068855@student.spbu.ru)

During last decades many different approaches for treatment of various severe diseases as based on nucleic acids (NA) have been developed. Application of plasmid DNAs (pDNAs) can initiate the expression of missing protein. On the contrary, such genetic constructs as antisense oligonucleotides (ASO) and small interfering RNAs (siRNA) can block expression of pathology-causing proteins [1]. The application of such genetic constructs is impossible without application of special delivery systems. There are two major competing approaches: viral and non-viral systems application. While viral systems are highly effective, they possess many potential hazards, such as immunogenicity and possible virulence. Non-viral NA delivery systems are presented by lipoplexes and polyplexes, formed with application of cationic lipids and polycations, correspondingly. Both systems are challenging for in vivo application due to their toxicity. In our recent studies we have shown, that polyplexes toxicity could be substantially reduced, while efficacy stay on a good level when competitive polyanion, such as heparin, is applied for NA binding together with polycation.

Current study is dealing with formation of interpolyelectrolyte complexes (IPECs) for NA encapsulation. The aim of the study was to test the ability of different binding polycations and competing polyanions to preserve the stability and functioning of different pharmacologically relevant NAs. Poly(L-lysine) (PLL) and chitosan were used as polycations, while heparin (Hep) and hyaluronic acid (HA) were tested as competitive polyanions. Model DNAs and RNAs were introduced into IPECs at different ratios. The change of obtained particles hydrodynamic radius and zeta-potentials in different media was detected for 1 month to check the stability of IPECs. Agarose gel electrophoresis was applied to investigate the stability of NAs, which were encapsulated into IPECs, towards different enzymes. Different factors affecting the stability of RNAs and DNAs were revealed.

Based on the result of abovementioned studies the best IPECs were chosen and tested for intracellular delivery of GFP-pDNA and anti-GFP siRNA. The determined appearance of GFP fluorescence and its disappearance, correspondingly, within relevant cell cultures were used for visual assessment of transfection efficacy. The flow-cytometry measurements were applied to obtain quantitative results on transfection as performed with application of developed IPECs.

## References

- [1] Chakraborty C., Sharma A.R., Sharma G., Doss C.G.P., Lee S.-S. *Mol. Ther. Nucleic Acids*. **2017**, 8, 132–143.
- [2] Pilipenko I., Korzhikov-Vlakh V., Sharoyko V., Zhang N., Schäfer-Korting M., Rühl E., Zoschke C., Tennikova T. *Pharmaceutics*. **2019**, 11, 317.

Acknowledgements. This work was supported by the Russian Science Foundation (project No 19-73-10045).



# SIMPLE AND TWO-STAGE PREPARATION OF SILICON-CONTAINING POLYNORBORNENES FOR GAS SEPARATION MEMBRANE MATERIALS

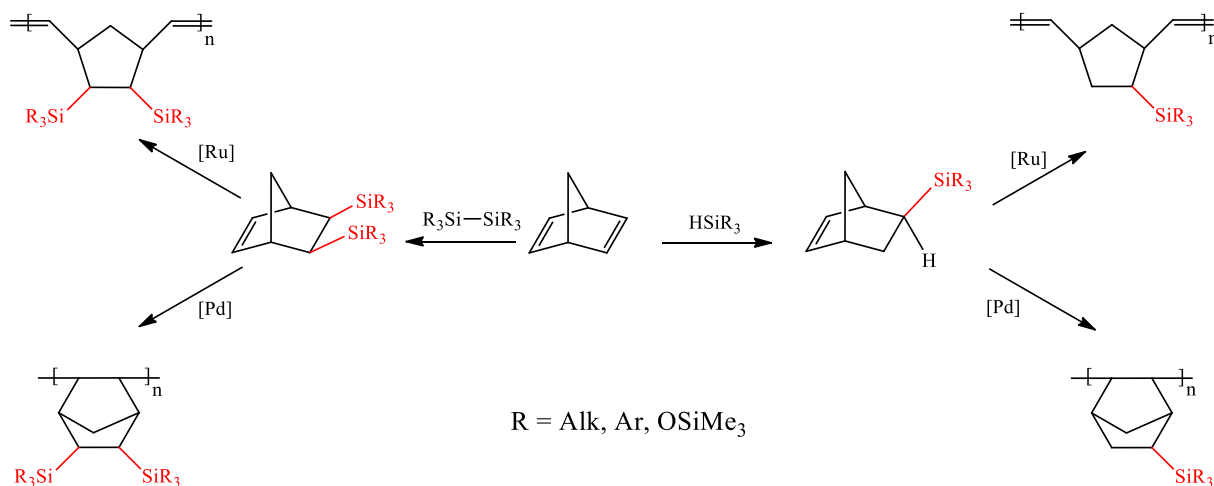
*Guseva M., Alentiev D., Bakhtin D., Borisov I., Volkov A., Finkelshteine E., Bermeshev M.*

A.V.Topchiev Institute of Petrochemical Synthesis RAS, Moscow, Russia  
PhD student  
[m.guseva@ips.ac.ru](mailto:m.guseva@ips.ac.ru)

The design of new polymer materials for membrane gas separation is now an actual problem of polymer science. Substituted norbornenes are attractive monomers for this purpose because they are able to impart interesting properties to polymers based on them.

However, common methods of preparing such monomers are difficult or not selective. Firstly, norbornenes synthesized by Diels-Alder reaction consist of the mixture of *exo*-/*endo*-isomers [1]. As a rule, *endo*-isomers are significantly less reactive in polymerization (especially, in addition polymerization) than *exo*-isomers [2]. This usually leads to low molecular weight products, possessing poor film-forming properties. Secondly, earlier developed approach to the synthesis of norbornenes with free *endo*-positions, namely the synthesis of *exo*-tricyclononenes by  $[2\sigma+2\sigma+2\pi]$ -cycloaddition reaction between quadricyclane and substituted olefins [3], is complicated by the sensitivity of this reaction to the nature of substituents, which necessitates bypass multi-stage synthesis [4,5].

In this work we proposed one-step selective method of synthesis of silicon-substituted norbornenes from synthetically available starting compounds. The method is based on the reaction between norbornadiene-2,5 and hydrosilanes or disilanes in the presence of Pd-, Rh- and Pt-based catalysts (Figure 1). Using this method, we synthesized a series of silicon-substituted norbornenes, differing in the number (one and two) and the nature of substituents (alkylsilyl, arylsilyl, siloxane and other moieties).



**Figure 1.** Synthesis and polymerization of Si-containing norbornenes.

The synthesized monomers were successfully involved in metathesis and addition polymerization. The prepared polymers were amorphous.

The gas transport characteristics of the obtained polymers were investigated for a wide range of gases (He, H<sub>2</sub>, O<sub>2</sub>, N<sub>2</sub>, CO<sub>2</sub>, CH<sub>4</sub>, C<sub>2</sub>H<sub>6</sub>, C<sub>4</sub>H<sub>10</sub>). In some cases, the characteristics were better than in the previously described polynorbornenes. During the work, it was found that the presence of Si–O–Si moieties in the side chain of polynorbornenes improved the permeability of C<sub>3+</sub> hydrocarbons. Structure property study and effect of *exo*-/*endo*-orientation of substituent on gas permeability was shown.

## References

- [1] Cunico R.F., et al. *J. Org. Chem.* **1971**, 36, 929–932.
- [2] Gringolts M.L., Bermeshev M.V., et al. *Silicon* **2015**, 7, 107–115.
- [3] Petrov V., Vasil'ev N., et al. *Curr. Org. Synth.* **2006**, 3, 215–259.
- [4] Bermeshev M.V., Syromolotov A.V., et al. *Macromolecules* **2011**, 44, 6637–6640.
- [5] Alentiev D.A., Chapala P.P., et al. *Mendeleev Commun.* 2016, 26, 530–531.

Acknowledgements. This work was carried out within the State Program of TIPS RAS.

# IN SITU SYNTHESIS OF SURFACE MOLECULARLY IMPRINTED POLYMERS FOR SENSING MAGNETITE NANOPARTICLES

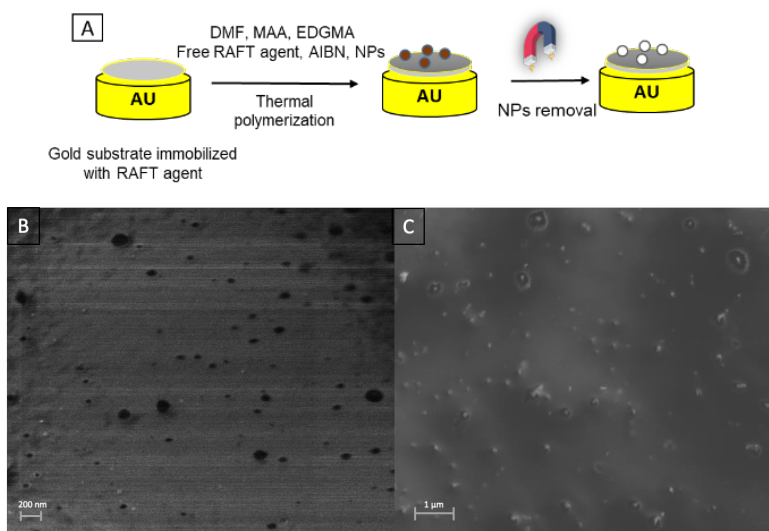
*Haghdoust S., Lieberzeit P.*

University of Vienna, Faculty for Chemistry, Department of Physical Chemistry, Vienna, Austria  
PhD student

[Shahin.haghdoust@univie.ac.at](mailto:Shahin.haghdoust@univie.ac.at)

Magnetite nanoparticles (MNPs) are beneficial to our daily lives through their application in biomedicine, industry and environmental remediation. Several, potential risks have been identified with the release of nanoparticles into the environment [1]. The increasing production and use of iron oxide NPs will inevitably result in a greater exposure risk. While a range of technologies, such as ICP-MS, SEM and TEM are available for the detection of engineered NPs, they suffer from expensive equipment and time consumption [2]. Hence, it is necessary to design sensors for straightforward screening measurements. Alternatively, molecularly imprinted polymers (MIPs) allow for designing robust receptor materials to capture the target analyte [3]. Moreover, MIPs can be combined with quartz crystal microbalances (QCMs) as the transducer to provide a user-friendly and rapid detection of engineered NPs in an aqueous medium.

Herein, we demonstrate synthesis of a surface imprinted polymer on reversible addition-fragmentation chain-transfer (RAFT) polymerization to grow polymer *in situ* from the surface of a gold electrode as a potential sensor material. For that purpose (4-Cyano-4-(phenylcarbonothioylthio) pentanoic acid served as the RAFT agent and was immobilized on the gold surface. Thereupon, the modified gold substrate directly immersed into the monomer mixture in Argon atmosphere and thermally polymerized at 60°C, followed by removing the particles (Figure 1A).



**Figure 1.** A) Schematic of *in situ* RAFT polymerization procedure on a gold substrate, B) SEM image of MIP surface (scale bar 200nm), C) SEM image of rebinding NPs into the MIP surface (scale bar 1μm).

Consequently, evaluation of MIP polymer with SEM reveals the successful cavities formation of  $\text{Fe}_3\text{O}_4$  NPs on the polymer surface which matched in terms of size and shape of corresponding MNPs (Figure 1B). Additionally, Figure 1C displays an SEM image of the significant rebinding ability of the MNPs into the created binding site on the MIP surface. Furthermore, the MIP polymer offers a concentration dependence sensor response with higher bonding affinity against  $\text{Fe}_3\text{O}_4$  NPs in comparison with the non-imprinted polymer based on QCM measurement.

## References

- [1] Magro M., *et al. Scientific Reports* **2018**, 8, 13017.
- [2] Tiede K., *et al. Food Additives and Contaminants* **2008**, 25, 795–821.
- [3] Wackerlig J. & Lieberzeit P.A. *Sensors and Actuators, B: Chemical* **2015**, 207, 144–157.

Acknowledgements. This work was supported by the Austrian Science Fund FWF, project number (I3568-N28).

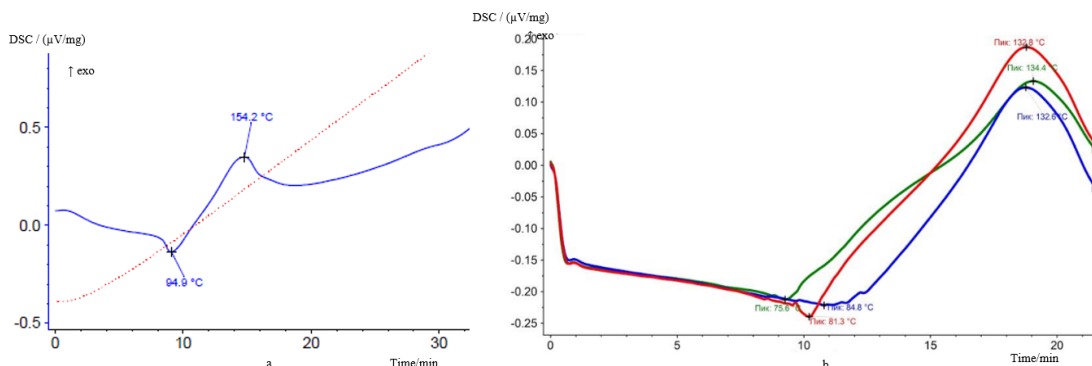
# IMPACT ASSESSMENT OF THE CURING ACCELERATOR ON THE POLYMERIZATION PROCESS OF THE COMPOSITE

*Hapankova A.I., Latyshevich I.A.*

Institute Of Physical And Organic Chemistry Of The National Academy Of Sciences Of Belarus  
PhD Student  
[elenagapankova@gmail.com](mailto:elenagapankova@gmail.com)

The analysis of the thermal curing of epoxy resin binders is a rather difficult task. Despite the fact that there are a huge number of different methods, we used the most reliable one - differential scanning calorimetry (DSC). The DSC method made it possible to determine the effect of the quantitative content of the curing accelerator of epoxy compositions used in the manufacture of prepregs on the change in the curing temperature depending on time, as well as to determine the process kinetics according to the obtained DSC curves. The result application in the creation of laboratory samples makes it possible to increase the reliability and accuracy of determining the composition technology and prepregs based on it.

The thermal behavior of the experimental materials was evaluated on a synchronous thermal analysis instrument STA 449 F3 Jupiter® (NETZSCH, Germany). The instrument combines a new system of high-tech thermobalances with a resolution of 1  $\mu\text{g}$  and a mass measurement accuracy of  $\pm 0.03$  mg. The DSC method allowed a reliable analysis of the curing accelerator effect on the overall curing process, which takes place in two stages. The first stage is the growth of branched macromolecules, and the second stage is the formation of a single net covering the material. According to the DSC curves obtained, including the temperature dependences of the enthalpy of the system under study over time, we were able to fix the form of the experimental DSC curve, characteristic for the phase transitions in the system under study without (a) and with (b) the curing accelerator.



**Figure 1.** Thermal analysis of adhesive prepregs.

The DSC method can be classified as a promising research method due to its rapidity. The DSC method is productive for studying chemical reactions of production and degradation of various polymeric materials, primarily by the parameters of thermal effects, in this case exothermic, which is typical for the curing of resins. The heat released during sample heating in the calorimeter, provided its mass remains unchanged during the experiment, is a direct reflection of the curing reaction. Measurements were taken in several stages: heating in the air atmosphere over a temperature range of 20 to 160 °C, continuous heating rate of 6 K/min; heating in the air atmosphere over a temperature range of 20 to 130 °C, continuous heating rate of 6 K/min; soaking at 130 °C for 20 min. We see an exothermic peak in the 132–154 °C temperature range. At 75–95 °C the boiling process of the liquid composite begins, as evidenced by the swelling of the sample recorded at the end of the measurement. The analysis of liquid adhesives with different content of curing agent (1.5–8.0 %) was made. In general, the adhesive composition based on epoxy resin and the developed terpenoid curing agent polymerizes more quickly and completely when the curing accelerator content is 4.5%, which contributes to an increase in the physical and mechanical properties of prepregs made on its basis, without reducing productivity and increasing material and energy costs. It can be seen that an increase in the amount of the injected curing accelerator leads to an increase in the formation rate of a strong three-dimensional matrix. Thus, the results obtained in this work are of undoubted importance for the technology of prepregs used for the production of composites for various purposes.

## DSC STUDY OF CURING OF EPOXY COMPOSITES WITH EMBEDDED METALLIC IRON NANOPARTICLES

*Il'inova K.O.<sup>1</sup>, Safronov A.P.<sup>1,2</sup>, Beketov I.V.<sup>1,2</sup>*

<sup>1</sup>Ural Federal University, Yekaterinburg, Russia

<sup>2</sup>Institute of Electrophysics of the Ural Division of the Russian Academy of Sciences, Yekaterinburg, Russia  
PhD Student

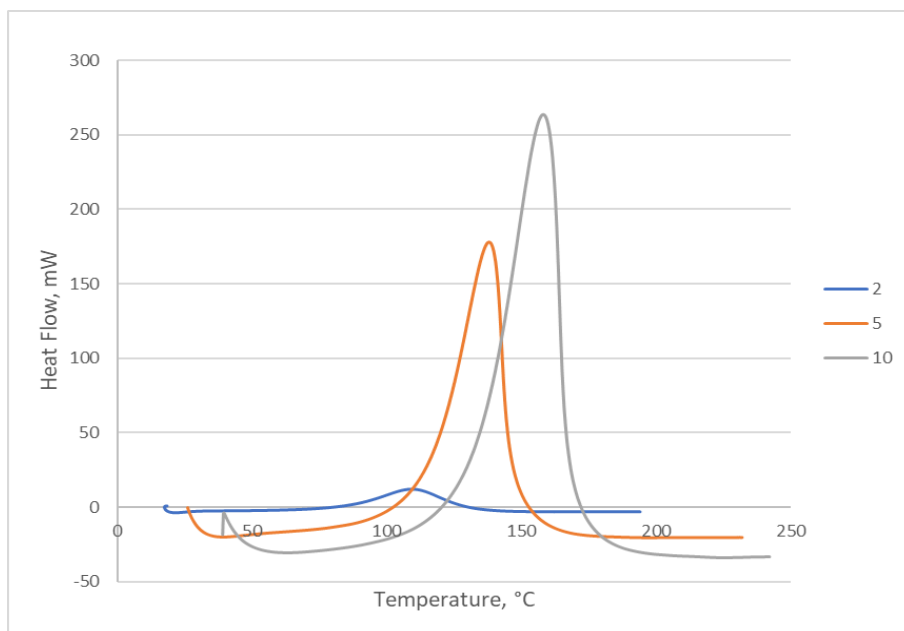
[ksenyailinova@mail.ru](mailto:ksenyailinova@mail.ru)

Epoxy resins (ER) are widely used as a polymer matrix of composite materials. A necessary stage in their production is the curing reaction. Typically, the curing of epoxy resins is performed using amine hardening agents. If nanoparticles with active surface are embedded in epoxy resin, potentially they can influence thermodynamic and kinetic parameters of the curing.

The purpose of this work was a calorimetric study of the curing process of epoxy composites filled with metallic iron nanoparticles, which were synthesized by a pulsed high power electrical evaporation of a metallic wire in an inert gas.

The study of the curing was carried differential scanning calorimetry (DSC). The composites were made using epoxy resin ED-20 and hardener m-phenylenediamine (MFDA) in the ratio (ER:MFDA) - 5:1. Iron nanopowder with a specific surface area of 9.0 m<sup>2</sup>/g was taken as a filler. It was obtained by the method of electric explosion of a wire at the Institute of Electrophysics of the Ural Division of the Russian Academy of Sciences. Iron nanoparticles were spherical with an average diameter of 97 nm. The filler content in the composite was 5, 10, 20, 30, and 40%. DSC studies were carried using a SETARAM DSC-131 scanning calorimeter in the linear heating mode at rates of 2, 5, and 10 K/min in the temperature range from 20 to 250 °C.

Typical thermograms obtained during the temperature scan are shown in Fig. 1. The curing reaction is accompanied by an exothermic peak in the temperature range 100–150 °C. With an increase in the heating rate, the exothermic peaks shift to higher temperatures. Obtained DSC thermograms were used for the determination of the enthalpy of curing of epoxy/nanoFe composites and for the calculation of the kinetic parameters of curing. The values of the maximum heat release increase sharply with the heating rate. It was shown that the embedding of iron nanoparticles into epoxy composite does not substantially influence the total enthalpy of curing but leads to a decrease in the temperature of maximum heat release by an average of 10 degrees.



**Figure 1.** Thermogram of curing ED-20: MFDA (5:1) with 5% Fe nanoparticles at different heating rates.

Acknowledgements. This work was supported by the financial support from the Russian Science Foundation (project No 20-12-00031).

*Ludin D.V.<sup>1</sup>, Korzhikova-Vlakh E.G.<sup>1,2</sup>*

<sup>1</sup>Saint Petersburg State University, Saint Petersburg, Russia

<sup>2</sup>Institute of Macromolecular Compounds of Russian Academy of Sciences, Saint Petersburg, Russia  
Student

[dmitriy-yudin97@mail.ru](mailto:dmitriy-yudin97@mail.ru)

The growing number of drug-resistant pathogenic bacteria poses a global threat to human health. According to the latest reports of WHO, the mortality from infectious diseases worldwide due to antibiotic resistance has been increased. Moreover, the rate of resistance spreading is outstripping the rate of the emergence of new antibiotics to combat them [1]. In this regard, there is a challenge to find ways to enhance the antibacterial activity of the existing antibiotics to counteract different infections more effectively.

This work proposes the creation of hybrid nanoparticles that consist of a silver core coated with a negatively charged poly(glutamic acid) shell as polymyxin delivery systems. These formulations could help to diminish the side effects of polymyxins, and may also become the system for synergistic therapy combining the antimicrobial effect of a silver core with the antibacterial activity of the antibiotics. Additionally, the polymyxin hybrid delivery systems were used as fillers for the preparation of hydrogel composite materials. The hybrid delivery systems can be considered for parenteral administration, while sustained-release composite materials are promising for transdermal treatment.

Poly(glutamic acid) was synthesized via ring-opening polymerization of N-carboxyanhydride using S-acetamidomethyl-L-cysteine as an initiator. The molecular weight characteristics of the obtained polymer were determined using gel permeation chromatography. After two-step removal of the protective groups from the polymer, the resulting poly(glutamic acid) was used in the redox reaction with silver nitrate to obtain the desirable nanoparticles by forming a donor-acceptor bond between cysteine and reducing silver. According to transmission electron microscopy data, the developed nanoparticles had a core-shell structure and their size corresponded to the data of dynamic light scattering. Electrophoretic light scattering showed that the hybrid particles have a negative  $\zeta$ -potential, which is good to entrap the positively charged polymyxin. The study of the cytotoxicity of the obtained system and free antibiotics was carried out for comparison in a wide range of concentrations. Flow cytometry was used to evaluate the uptake rate of hybrid systems by macrophages. The results demonstrated a lack of cytotoxicity of nanoparticles as well as a low uptake rate by macrophages that important for further experiments in vivo. The features of polymyxins encapsulation in the obtained particles were studied, and such important characteristics as drug loading and encapsulation efficiency were determined. The composite materials based on agarose gel were prepared, containing both loaded hybrid systems and free antibiotics. The features of the polymyxins release from hybrid nanoparticles and composite materials in a model solution were studied. The antibacterial activity of both empty hybrid particles and loaded forms was determined. The results showed that empty nanoparticles have their own antibacterial activity, and in the case of the encapsulated system, a synergistic effect was observed.

## References

[1] Willyard C., The drug-resistant bacteria that pose the greatest health threats, *Nature*, **2017**, 543 (7643).

Acknowledgement. This work was supported by Russian Science Foundation (project № 19-73-20157).

# COMB-LIKE POLYELECTROLYTES FOR MICELLAR HYDROLYSIS REACTIONS

*Kadnikov M.V.<sup>1</sup>, Fetin P.A.<sup>1</sup>, Zorin I.M.<sup>1</sup>*

<sup>1</sup>Saint Petersburg State University, Saint Petersburg, Russia  
Student  
st061237@student.spbu.ru

The phenomenon of micellar catalysis is known and is used in organic synthesis when carrying out organic reactions in aqueous solution [1]. For these purposes, low molecular weight surfactants are usually used. In this work, we decided to expand the range of objects used for the purposes of micellar catalysis to comb-like polyelectrolytes, since they have a number of valuable properties:

- Possibility of surfactant regeneration after the reaction;
- High solubilization capacity;
- Low association thresholds, practically equal to zero.

Therefore, the purpose of this work was to evaluate the possible use of comb-like polyelectrolytes for micellar catalysis. Micellar catalysis can find application in various fields of science and technology. For example, it can be used to dispose of plastic and decontaminate certain chemical warfare agents [2], [3], as well as to simulate enzymatic catalysis conditions in the development of drug delivery systems. The aim of this work was to evaluate the possible use of comb-like polyelectrolytes for micellar catalysis. The following polyelectrolytes have been synthesized: poly-11-acryloxyundecyltrimethylammonium bromide (pAUTAB), as well as its triethyl-, pyridine-, quinoline- and N-methylmorpholine analogs. These compounds were used as catalysts in the hydrolysis reaction of a model ester of para-nitrophenyl butyrate. The rate constants of the hydrolysis reaction were determined from the analysis of the UV spectra of the products of the studied reaction. Analyzing certain constants of hydrolysis, according to various kinetic models, we determined the physicochemical parameters of this catalytic process. The dependence of their values on the type of polar group of the cationic polyelectrolyte is discussed in the work.

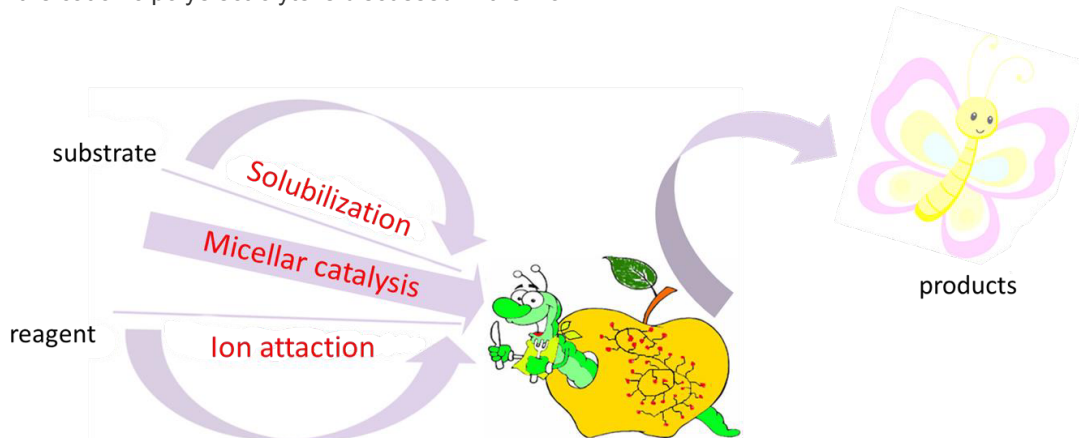


Figure 1. Micellar Catalysis - illustrative schema

**Acknowledgements.** The reported study was funded by RFBR and BRFFR, project number 20-53-04017. The authors are grateful Center for magnetic resonance, Interdisciplinary Resource Centre for Nanotechnology, Centre for Diagnostics of Functional Materials for Medicine, Pharmacology and Nanoelectronics of Saint Petersburg State University.

## References

- [1] Shen T. et al., *Advances in Colloid and Interface Science*, vol. 287. Elsevier B.V., p. 102299, **2021**.
- [2] Dwars T., Paetzold E. and Oehme G., *Angew. Chemie - Int. Ed.*, vol. 44, no. 44, pp. 7174–7199, **2005**.
- [3] Pashirova T.N. et al., *Chempluschem*, vol. 85, no. 8, pp. 1939–1948, **2020**.

# DEVELOPMENT OF NOVEL PYRROLIDINE-BASED GEL POLYMER ELECTROLYTES FOR LITHIUM-ION BATTERIES

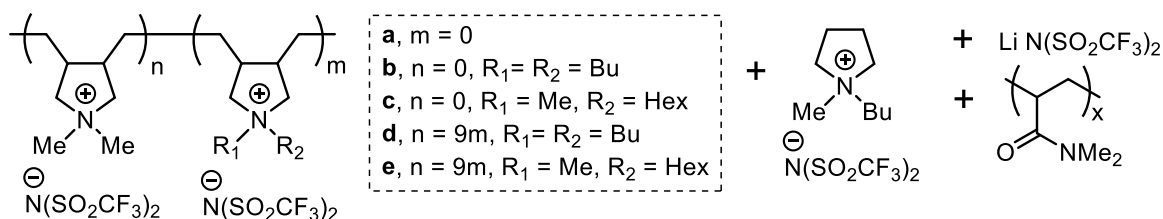
*Kamenskii M.A.<sup>1</sup>, Li B.<sup>1</sup>, Vlasov P.S.<sup>1</sup>, Eliseeva S.N.<sup>1</sup>*

<sup>1</sup>Saint Petersburg State University, Saint Petersburg, Russia  
Ph. D. student  
[kamenskiim689@gmail.com](mailto:kamenskiim689@gmail.com)

One of the key disadvantages of lithium-ion batteries is the leak of toxic and flammable liquid electrolytes based on hexafluorophosphate and carbonate esters (dimethyl carbonate, ethyl carbonate etc). A possible way to solve this problem and increase the stability and safety of the battery is to exchange the liquid electrolyte to solid or quasi-solid composition. From this point of view, gel polymer electrolytes (GPE) combine properties of liquid and solid electrolytes and have several benefits like high ionic conductivity, good mechanical properties and flexibility. Many polymers were applied as matrix for GPE like polyethylene oxide, polyvinylidene fluoride [1] and cellulose derivatives [2].

Pyrrrolidinium ionic liquids and polymeric ionic liquids [3] are promising components for GPE development due to their variable chemical properties like thermal and electrochemical stability, high ionic conductivity, nontoxicity and non-flammability. Some ILs were applied in liquids and polymeric electrolytes for lithium-ion batteries [4].

This work aimed the investigation of electrochemical properties of novel gel polymer electrolytes based on pyrrolidinium cationic polyelectrolytes (Fig. 1). Various substituted N,N-diallylammonium polymers and copolymers were plasticized with ionic liquid and reinforced by blending with poly(N,N-dimethylacrylamide). The mixed polymer electrolytes were cast from DMF solutions on the stainless-steel disk and on the LiFePO<sub>4</sub> (LFP) cathode and dried in vacuum before testing.



**Figure 1.** Chemical structure of GPEs studied.

Ionic conductivity was determined by impedance spectroscopy measurements of GPE films between two stainless steel disks in temperature range 5 – 60 °C. Electrochemical stability window was studied by cyclic voltammetry measurements of steel/lithium cells in a potential range -0.1 – 5.0 V vs. Li/Li<sup>+</sup> with a scan rate of 0.2 mV·s<sup>-1</sup> at 60 °C. Electrochemical performance of LFP/Li cells with GPEs was measured by galvanostatic charge discharge at current density 0.1 C (equal to 17 mA·g<sup>-1</sup>) and by cyclic voltammetry at the same scan rate in the potential range 2.0 – 4.0 V 60 °C.

All polymer electrolyte showed satisfactory ionic conductivity near 10<sup>-7</sup> – 10<sup>-5</sup> Sm·cm<sup>-1</sup> which obviously increased with the increase of temperature. The highest conductivity was observed at 60 °C, so further examination was performed at this temperature. It was demonstrated that all GPEs are stable in a cathodic potential window and has no significant peaks except strong peak of polyamide oxidation in case of combination F. Tests of LFP/Li cells with GPEs show low specific capacity values (12 and 30 mAh·g<sup>-1</sup>) which can be explained by small diffusion of the electrolyte in the pores of cathode material.

## References

- [1] Long L., Wang S., Xiao M., Meng Y. *J. Mater. Chem. A* **2016**, *4*, 10038–10039
- [2] Zhao L., Fu J., Du Z., Jia X., Qu Y., Yu F., Du J., Chen Y. *J. Memb. Sci.* **2020**, *593*, 117428
- [3] Döbbelin M., Azcune I., Bedu M., Ruiz De Luzuriaga A., Genua A., Jovanovski V., Cabañero G., Odriozola I. *Chem. Mater.* **2012**, *24*, 1583–1590
- [4] Porcarelli L., Vlasov P.S., Ponkratov D.O., Lozinskaya E.I., Antonov D.Y., Nair J.R., Gerbaldi C., Mecerreyes D., Shaplov A.S. *Eur. Polym. J.* **2018**, *107*, 218–228

Acknowledgements. This work was supported by Russian Foundation for Basic Research (project No 20-53-56069).



POLY(LACTIC ACID) BASED NANOPARTICLES FOR CONTROLLED RELEASE  
OF CARBONIC ANHYDRASE INHIBITORS

*Karaulova A.N.<sup>1</sup>, Sinitsyna E.S.<sup>1</sup>, Kalinin S.A.<sup>1</sup>, Korzhikov-Vlakh V.A.<sup>1</sup>*

<sup>1</sup>Saint Petersburg State University, Saint Petersburg, Russia

Student

[st086538@student.spbu.ru](mailto:st086538@student.spbu.ru)

Carbonic anhydrase inhibitors (CAIs) are used topically and systemically in glaucoma treatment, but the current compounds have adverse effects and relatively short duration of action, resulting in low patient compliance (~50%) and sub-optimal therapeutic outcomes (i.e. impaired vision and even blindness). CAIs act on carbonic anhydrase in the ciliary body of the eye, reducing the production of aqueous humor and intraocular pressure (IOP). A range of compounds with enhanced selectivity and affinity to target enzyme CA-II have been synthesized in the workgroup of Prof. Mikhail Krasavin at Institute of Chemistry of St Petersburg State University [1-2]. With their superior activity to the clinically used inhibitors, some structures revealed unusual hydrophilicity which might be beneficial for the drug retention at the site of action. Indeed, these hydrophilic compounds proved very effective in lowering intraocular pressure in rabbits after topical ocular administration [1].

Fast CAIs clearance from the ocular surface is a problem of their topical application in the form of eye drops. Thus, there is a need for development of particulate formulations capable of encapsulation and controlled release of CAIs. Previously we have developed nanoparticles (NPs) based on poly(lactic acid) (PLA), which can encapsulate and release low-molecular drugs in a controlled manner [3]. The aim of this study was to obtain PLA based NPs capable of encapsulation and long release of CAI.

PLA was obtained by ring-opening polymerization of lactide with application of stannous octoate as initiator. The obtained polymer was characterized by size-exclusion chromatography. NPs were formed via nanoprecipitation protocol, which was optimized to obtain formulations with maximum encapsulation efficacy and drug loading. Obtained nanoparticles were characterized by dynamic and electrophoretic light-scattering and TEM. The CAI release studies were performed in the biorelevant conditions and showed the ability of developed systems to release drug during at least one month. The *in vitro* and *in vivo* biological testing of obtained formulations is ongoing.

#### References

- [1] Kalinin S.A. et al. *J. Enzyme Inhib. Med. Chem.* **2016**, 31, 185–199.
- [2] Krasavin M.Yu. et al. *Eur. J. Med. Chem.* 2019, 164, 92–105.
- [3] Korzhikov V.A. et al. *J. Microencapsul.* **2016**, 33 (3), 199-208.

Acknowledgements. This work was supported by Megagrant of Russian Government (agreement #14.W03.31.0025). Authors are grateful to Centre for Molecular and Cell Technologies of research park of SPbU for TEM imaging of nanoparticles.

# METAL-FREE APPROACH FOR ACTIVATION OF Pd-PRECATALYSTS FOR ADDITION POLYMERIZATION OF CYCLIC OLEFINS

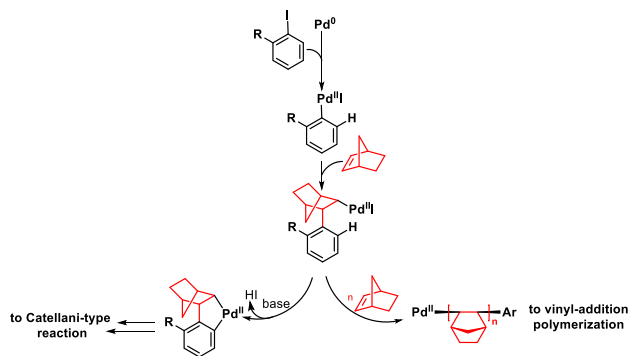
*Karpov G.O.<sup>1</sup>, Bermeshev M.V.<sup>1</sup>*

<sup>1</sup>A.V.Topchiev Institute of Petrochemical Synthesis, Moscow, Russia  
PhD Student  
karpov@ips.ac.ru

Norbornene and its derivatives represent an attractive class of monomers for a targeted design of materials with improved properties. The wealth of synthetic approaches for obtaining various norbornene derivatives containing the desired kind of substituent in the demanded position provides a rich ground for the research. High polymerization reactivity of such derivatives helps establish valuable correlations between the structure of the monomer unit and the properties of the resulting polymer. More specifically, vinyl-addition polymerization of norbornene derivatives has recently become a powerful tool for the design of polymers with rigid and saturated backbone, which, in turn, provides a set of valuable properties: high thermal and chemical stability, improved transparency, and free volume characteristics [1]. However, the development of simple, stable, and efficient catalytic systems remains a key issue in the synthesis of vinyl-addition polynorbornenes.

Nowadays catalysts used for addition polymerization of cycloalkenes are based on early and late transition metal complexes/salts (precatalysts) activated by a Lewis acid (perfluorinated boranes, aluminorganic compounds or their combination), leading to the formation of an easily accessible coordination site and subsequent generation of truly active catalytic species containing metal-carbon or metal-H bond. Such system based on Ni- or Pd-precatalysts can polymerize various norbornene derivatives with high yields. However, organometallic activators are usually water and oxygen-sensitive, thus, complicating polymerization. On the other hand, organometallic reagents are expensive and can negatively affect material properties. In the present work, we suggest a novel approach for activation of Pd-precatalysts for addition polymerization of cycloalkenes based on metal-free organic reagents.

The suggested approach is based on the use of organic Ar-X (X – halogen, OTf, N<sub>2</sub><sup>+</sup>OTf or N<sub>2</sub><sup>+</sup>BF<sub>4</sub><sup>-</sup>) compound containing a reactive C-X bond. Such compounds were shown to successfully interact with Pd-complexes during the oxidative addition stage of many common organic reactions. Moreover, it was demonstrated that the interaction of norbornene with the formed Ar-Pd-X complexes leads to a norbornene insertion during the Catellani-type reactions [2]. Herein we demonstrated the activation of Pd-precatalysts with metal-free Ar-X organic compound in addition polymerization of cyclic olefins for the first time [3].



**Figure 1.** Possible first stages of Catellani-type reactions and addition polymerization of norbornene.

The activity of the new type of catalytic systems was studied in detail. Influence of nature of halogen or other X-part of Ar-X compound on catalytic activity was estimated. It was shown that the introduction of different substituents in Ar-X helps regulate the activity of the catalyst formed. A new type of catalytic system polymerized various norbornene derivatives in moderate or high yields.

## References

- [1] M. V. Bermeshev and P.P. Chapala, *Prog. Polym. Sci.* **2018**, 84, 1-46.
- [2] N. Della Ca, M. Fontana, E. Motti, and M. Catellani, *Acc. Chem. Res.* **2016**, 49, 1389-1400.
- [3] G.O. Karpov, X.-K. Ren, E.K. Melnikova, and M. V Bermeshev, *Chem. Commun.* **2021**, 57, 4255-4258.

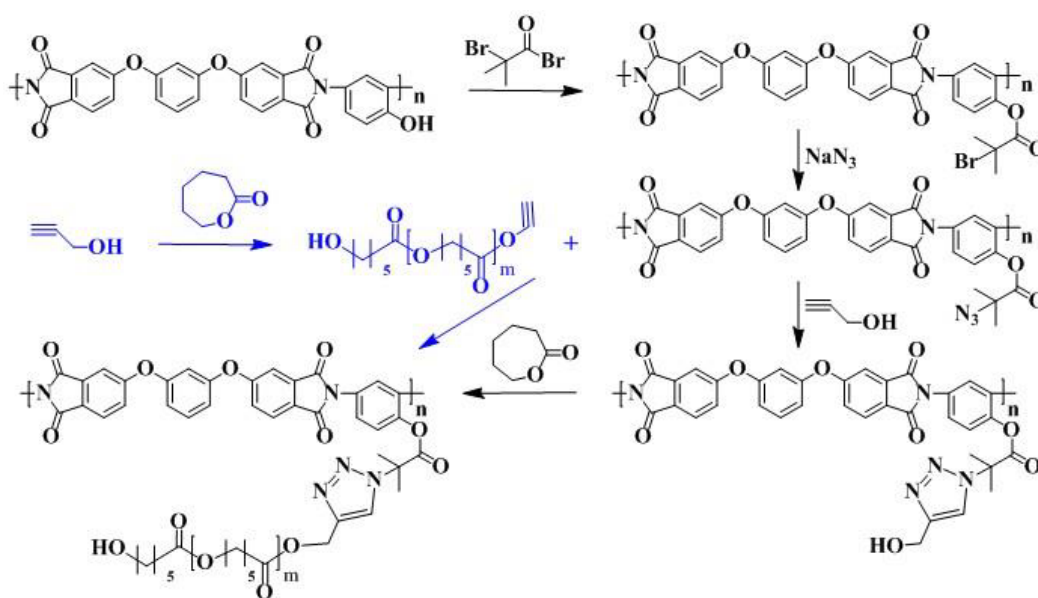
Acknowledgements. This work was supported by the Ministry of Education and Science of the Russian Federation (project no. MD-1818.2020.3).

POLYCONDENSATION-POLYMERIZATION GRAFTED COPOLYIMIDES  
WITH POLY( $\epsilon$ -CAPROLACTONE) SIDE CHAINS

*Kashina A.V., Ivanov I.V., Meleshko T.K., Bogorad N.N., Yakimansky A.V.*

Institute of macromolecular compounds of Russian Academy of Sciences, Saint Petersburg, Russia  
Young scientist  
[kashina.anna@mail.ru](mailto:kashina.anna@mail.ru)

The development of new innovative technologies in the science-intensive fields of engineering and biomedicine stimulates the production of new polymers with specified and controlled properties. One of the priority of modern polymer chemistry, due to the increased requirements for the developed polymer materials, is the synthesis of new copolymer structures with specified molecular and structural characteristics. The trends in the development of modern polymer chemistry imply the complication of the architecture of synthesized polymers, which makes it possible to obtain materials with previously unattainable properties. For example, ternary multiblock copolymers of mixed linear-brush topology with a central "brush" block and peripheral linear blocks have shown their promise for the creation of synthetic ultra-soft elastomers.



**Figure 1.** Two approaches to the synthesis of grafted copolyimides with PCL side chains.

The combination of covalently linked blocks of aromatic and aliphatic nature in one macromolecule is of undoubted interest, since it opens up the possibility of varying the properties of copolymers within wide range. This work is devoted to the synthesis of polymer molecular brushes with poly( $\epsilon$ -caprolactone) (PCL) side chains directly grafted to the polyimide (PI) backbone. For this, a combination of polycondensation, ring opening polymerization (ROP) and azide-alkyne cycloaddition (click reaction) was used. We compared two synthetic routes: (1) using polymer-analogous transformations of a multicenter PI macroinitiator with an initiating hydroxyl group separated from the main chain by a triazole ring and carrying out ring-opening polymerization on it, or (2) a separate synthesis of macromonomers with the desirable functional groups (polyimide with azide groups in each repeating unit and PCL with terminal alkyne groups), followed by a click reaction.

Acknowledgements. This work was supported by Ministry of Science and Highest Education of the Russian Federation, Grant/AwardNumber: 14.W03.31.0022.

# SYNTHESIS AND PROPERTIES OF LUMINESCENT POLYMER BRUSHES PF-*graft*-PMAA

*Kaskevich K.I., Ilgach D.M., Simonova M.A., Litvinova L.S., Yakimansky A.V.*

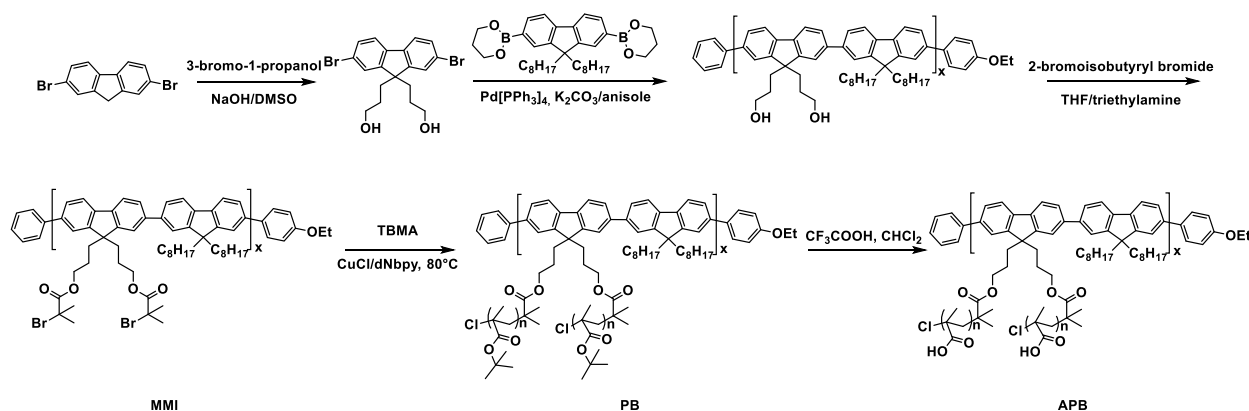
Institute of Macromolecular Compounds Russian Academy of Sciences, Saint Petersburg, Russia

PhD student

[kaskevich-ksenia@yandex.ru](mailto:kaskevich-ksenia@yandex.ru)

Polymer brushes (PB) based on conjugated polymers combine the ability to luminescence and unique architecture. Polyfluorenes are of particular interest due to their high values of quantum yields. Therefore, the work is devoted to the study of luminescent amphiphilic polymer brushes (APB) based on polyfluorene with side chains of polymethacrylic acid of various lengths. The relevance of this work is that such systems are capable of forming unimolecular micelles in solution, which can be used in nanomedicine for drug delivery and bioimaging [1].

For the synthesis of APBs, a multicenter macroinitiator (MMI) was obtained according to a well-known technique [2]. PBs with poly-*tert*-butyl methacrylate (PB) side chains were synthesized using the atom transfer radical polymerization (ATRP) mechanism and grafting from technique, and then APBs were obtained by protonolysis of the ether groups. The synthesis scheme is shown in Figure 1. The length of the side chains was varied by the molar ratio of the initiating group: monomer, as well as by the reaction time. The molecular weights of the obtained samples were determined by gel permeation chromatography on three detectors.



**Figure 1.** Scheme of the synthesis of PF-*graft*-PMAA.

The study of the spectral characteristics of solutions of PBs and APBs shows that the luminescence intensity of PBs is higher than that of MMI, despite the fact that the mass fraction of the luminescent polymer is higher in MMI compared to PBs, in which only the main chain luminesces. It was found that an increase in the length of the side chains leads to an increase in the quantum yield of the PB, and when the corresponding APB is formed by protonolysis, it leads to an insignificant decrease in the quantum yield.

It was shown by dynamic light scattering that the injection of an alcohol solution of APB into water during sonication leads to the formation of rod-shaped unimolecular micelles. Using a model substance, curcumin, the possibility of forming nanocontainers was investigated.

## References

- [1] Müllner M. *Macromol. Chem. Phys.* **2016**, 217, 2209–2222.
- [2] Zhang Z., Fan Q., Sun P., Liu L., Lu X., Li B., Quan Y., Huang W. *Macromol. Rapid Commun.* **2010**, 31, 2160–2165.

**Acknowledgements.** This work was supported by megagrant of the Ministry of Science and Highest Education of the Russian Federation (state contract no. 14.W03.31.0022).

INTERPOLYELECTROLYTE COMPLEXES CROSS-LINKED WITH KETAL LINKER:  
pH-SENSITIVE SYSTEMS FOR siRNA AND pDNA DELIVERY

*Khazanova M.A.<sup>1</sup>, Pilipenko I.M.<sup>1</sup>, Korzhikov-Vlakh V.A.<sup>1</sup>*

<sup>1</sup>Saint Petersburg State University, Saint Petersburg, Russia  
Student

[khazanova\\_m@icloud.com](mailto:khazanova_m@icloud.com)

In recent years different genetic constructions become more and more important as effective substitutes for chemotherapy with application of small drug molecules. However, a serious problem of modern gene therapy is the delivery of a therapeutic genetic construct into target cells. It is also important to minimize its contacts with the biological media of the body until the target intracellular localization is achieved. This point is extremely important to ensure the efficiency and safety of the transfection process. Therefore, the development of effective vector systems capable of safely delivering of nucleic acids (NAs) to their site of action is one of the most important challenges facing modern science. These vectors should protect the drug from the action of the aggressive environment of the body and systemic distribution until it penetrates the target cells. Only after this a rapid release of the therapeutic construct should take place. To realize such a variant, it is necessary to develop special “smart” systems that are sensitive to certain stimuli.

This work is devoted to obtaining and studying the properties of pH-sensitive systems for induced intracellular delivery of therapeutic genetic constructs based on the difference in pH of the extracellular and intracellular environments. The strategy for covalent crosslinking of interpolyelectrolyte complexes (IPECs) as based on chitosan and heparin methacrylates using thiol-ene “click” chemistry was developed and implemented to create desired systems. The application of specially synthesized pH-sensitive ketal cross-linker allowed to obtain systems that are stable in the extracellular environment, but able to degradation and release inside the cells, namely at acidic pH.

Acknowledgements. This work was supported by the Russian Science Foundation (project No 19-73-10045). Authors are grateful to Molecular and Cell Technologies, and Magnetic Resonance Research Centers of research park of SPbU.

# THE EFFECT OF THE AQUATIC ENVIRONMENT OF POLYMER BLENDS BASED ON POLYLACTIDE AND LOW DENSITY POLYETHYLENE

*Khramkova A.V.*<sup>1</sup>, *Tertyshnaya Yu.V.*<sup>2,3</sup>, *Podzorova M.V.*<sup>2,3</sup>

<sup>1</sup> MIREA — Russian technological university, Moscow, Russia

<sup>2</sup> Plekhanov Russian University of Economics, Moscow, Russia

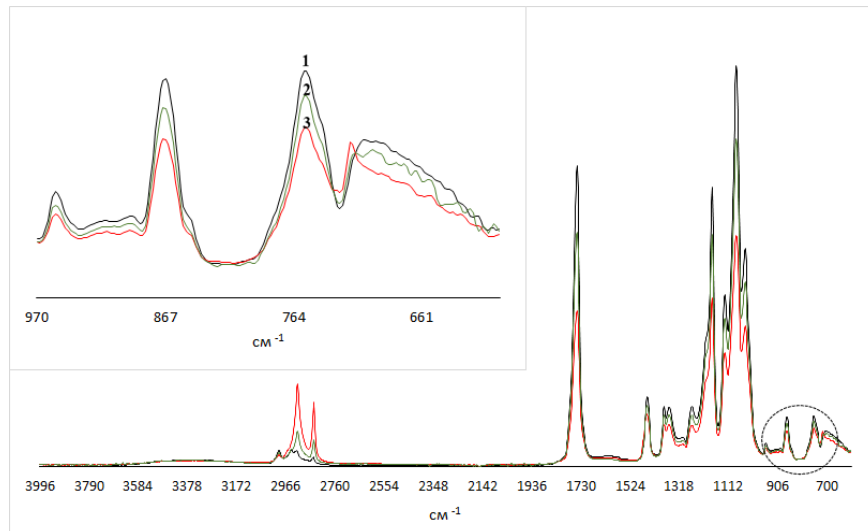
<sup>3</sup> Emanuel Institute of Biochemical Physics Russian Academy of Sciences, Moscow, Russia

Student

[mariapdz@bk.ru](mailto:mariapdz@bk.ru)

The humidity of the air or the water somehow affects the polymer materials and products made from them. Water diffusion is often the limiting step in the hydrolytic decomposition of the polymer. In hydrophobic polymers, such as polyolefins, polyesters, and polysiloxanes, the diffusion coefficient is low but the polylactide (PLA) undergoes hydrolysis [1]. The degradation of the PLA matrix may be divided into two stages: first, there is a random hydrolytic cleavage of the ester bonds with the diffusion of water into the amorphous regions, and then hydrolytic degradation occurs from the edge to the center of the crystal domains with the degradation of the main sections of the amorphous zone [2].

In the work, we study the process of hydrolytic degradation of film samples of polylactide-polyethylene blends in distilled water and electrolyte solution. After exposure to saline solution for 240 hours at  $T=22\pm 2^\circ\text{C}$ , the degree of crystallinity of polylactide increases by 2-3 % in all samples with a decrease in the melting point by  $1-2^\circ\text{C}$ .



**Figure 1.** IR spectra of the 50PLA/50LDPE sample: initial (1), after the action of a solution of NaCl (0.9%) (2) and distilled water (3).

After the action of water and a solution of NaCl (0.9%) on the PLA/LDPE samples on the IR spectra (Fig. 1), significant changes are clearly visible in the region of various vibrations of the ester groups ( $1300-980\text{ cm}^{-1}$ ), the intensity of the bands of which is much lower after the action of distilled water (3) compared to the initial one (1) and after degradation in saline solution (2), which indicates a greater depth of the hydrolysis process in distilled water. Visible changes in the structurally sensitive bands  $755$  and  $870\text{ cm}^{-1}$  are observed, which relate to the  $\text{C}-\text{C}$  vibrations of the crystalline and amorphous phases of the polylactide, respectively [3]. The structurally sensitive band  $720\text{ cm}^{-1}$ , which belongs to the vibrations of the  $\text{C}-\text{C}$  bonds of polyethylene (Fig. 1 (3)), becomes more distinct after the action of distilled water on the sample 50PLA-50LDPE, i.e. after the partial degradation of the polylactide matrix.

## References

- [1] Podzorova M. V., Tertyshnaya Y. V., Pantyukhov P. V., Shibryaeva L. S., Popov A. A., Nikolaeva S. *AIP Conference Proceedings*. **2016**, 1783, 020185
- [2] Moataz A. Elsayy, Ki-Hyun Kim, Jae-Woo Park, Akash Deep. *Renewable and Sustainable Energy Reviews*, **2017**, 79, 1346-1352
- [3] Paula E., Mano V., Pereira F.V. *Polym. Degrad. Stab.* **2011**, 96, 1631-1638.

# CROSS-LINKED POLYMER NETWORKS BASED ON POLYSILOXANES AND METAL $\beta$ -DIKETONATES

*Kim E.E.<sup>1</sup>, Kononevich Yu.N.<sup>1</sup>, Vysochinskaya Yu.S.<sup>1</sup>, Shchegolikhina O.I.<sup>1</sup>, Vasil'ev V.G.<sup>1</sup>, Busin M.I.<sup>1</sup>, Khanin D.A.<sup>1</sup>, Muzafarov A.M.<sup>1,2</sup>*

<sup>1</sup>A.N. Nesmeyanov Institute of Organoelement Compounds of Russian Academy of Sciences, Moscow, Russia

<sup>2</sup>N.S. Enikolopov Institute of Synthetic Polymeric Materials of Russian Academy of Sciences, Moscow, Russia

PhD student

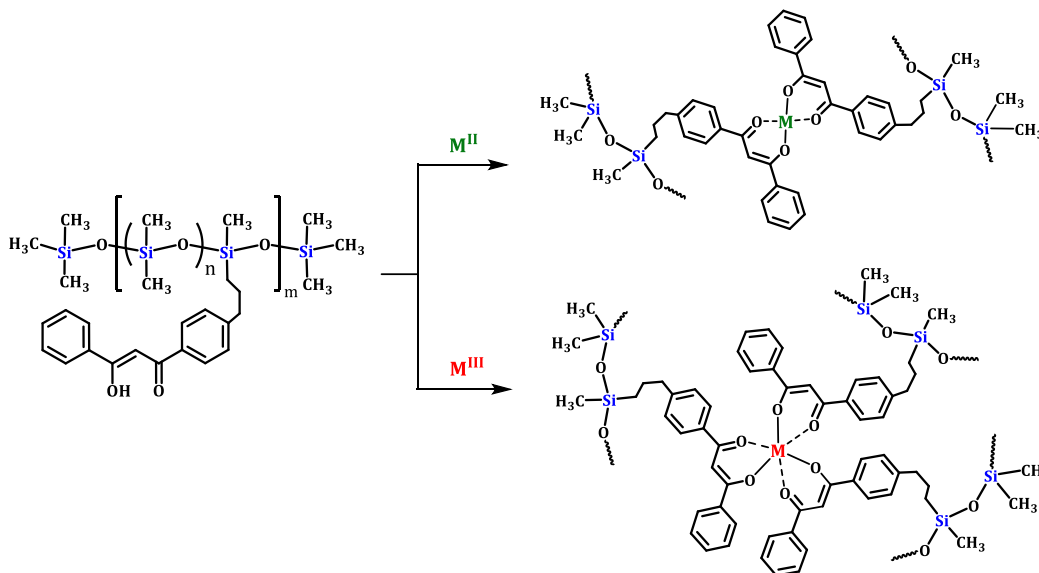
[ela-kim@mail.ru](mailto:ela-kim@mail.ru)

The design and synthesis of coordination polymers occupy an increasingly prominent place in various fields of science and technology. Polymers cross-linked by metal-ligand interaction can find application at the development of new smart materials such as coordination polymers with shape-memory, self-healing and stimuli-responsive properties, elastomers with enhanced mechanical properties, hydrogels with tunable strength and thermosensitivity, etc [1].

One of the prospective polymeric ligands for this purpose seems to be ligand-contained polysiloxanes which occupy a unique niche among special purpose materials [2]. Due to the unique combination of inorganic siloxane backbone and organic side-chain substituents, siloxanes possess a wide range of outstanding physicochemical properties, including high flexibility and transparency, great thermal and chemical resistance, excellent dielectric properties and biocompatibility. Among various ligands  $\beta$ -diketones are one of the most widely used class of ligands that effectively could chelate different metal ions and form the corresponding non-charged chelate complexes.

Varying different ions of metals, it is possible to obtain materials with various structure and properties. Thus, one can synthesize compounds with different color, thermal and mechanical properties, introducing various fillers of metal salts. A fluorescent films can be made by using rare-earth metals.

In this work, in order to reinforce the mechanical performance of cross-linked polysiloxanes and give characteristic properties inherent to metal  $\beta$ -diketonates we show the possibility of successful combination of polysiloxane polymer and metal  $\beta$ -diketonate unit in the one polymer network [3]. A series of new non-charged polymers cross-linked by metal ions with different valency have been prepared and fully characterized. Also, mechanical, rheological, thermal and optical properties of obtained materials were investigated. Such hybrid polymers are promising candidates at the development of new smart materials with unique properties.



**Figure 1.** Synthesis of polymers cross-linked by metal ions with various valency

## References

- [1] Lai J.C., Li L., Wang D.P., *Nat. Commun.* **2018**, 9, 2725-2734.
- [2] Yi B., Wang S., Hou C. *Chem. Eng. J.*, **2021**, 405, 127023
- [3] Kim E.E, Kononevich Yu.N., Muzafarov A.M. *React. Func. Polym.* **2021**, 164, 104896

Acknowledgements. This work was supported by the Russian Science Foundation (project No 18-73-10152).



# SYNTHESIS OF RANDOM COPOLYMERS BASED ON $\alpha$ -AMINO ACIDS

*Klaving A.V.<sup>1,2</sup>, Zashikhina N.N.<sup>2</sup>, Korzhikova-Vlakh E.G.<sup>1,2</sup>*

<sup>1</sup>Saint Petersburg State University, Saint Petersburg, Russia

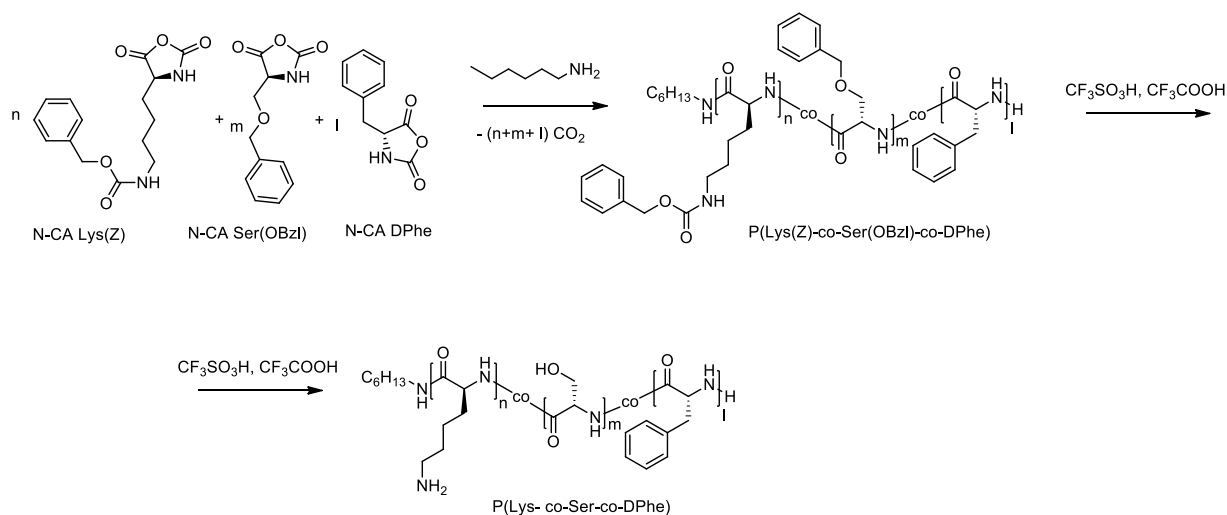
<sup>2</sup>Institute of Macromolecules Compounds, Russian Academy of Sciences, Saint Petersburg, Russia  
Student

[anastasiia.klaving@gmail.com](mailto:anastasiia.klaving@gmail.com)

Random amphiphilic copolymers based on  $\alpha$ -amino acids are of particular interest due to their biocompatibility, biodegradability and low toxicity [1]. One of the key properties of amphiphilic copolymers is their ability to self-assembly in aqueous media, resulting in the formation of nano- and submicron particles that are promising as drug delivery systems [2]. Thus, the synthesis of new biodegradable amphiphilic copolymers and the study of the effect of their composition on the characteristics of the resulting particles is undoubtedly urgent [3].

A number of monomers were synthesized, namely N-carboxyanhydrides (N-CA) of  $\alpha$ -amino acids by the Fuchs-Farthing method. A series of random double and terpolymers based on L-glutamic acid (Glu) / L-lysine (Lys), L-serine (Ser) and D-phenylalanine (D-Phe) were obtained by the ring-opening copolymerization method using a primary amine as an initiator. The relative activity of the different monomer pair in the copolymerization process was calculated with Fineman–Ross method at the initial stages of polymerization. The composition of synthesized copolymers was determined by <sup>1</sup>H NMR spectroscopy. For the studied N-CAs, their activity does not depend on the nature of the radical in the side chain of the comonomer, and the synthesized copolymers have a random sequence of units.

After deprotection of hydrophobic copolymers the following amphiphilic polypeptides were prepared: P(Lys-co-Ser), P(Glu-co-Ser), P(Lys-co-Ser-co-DPhe) and P(Glu-co-Ser-co-DPhe) (Fig. 1).



**Figure 1.** Synthesis of random terpolymer P(Lys-co-Ser-co-DPhe).

Particles based on the synthesized copolymers were obtained using the gradient phase inversion method. The dependence of particle characteristics (hydrodynamic diameter, polydispersity index, and  $\zeta$ -potential) on the composition of the obtained copolymers was studied by the methods of dynamic and electrophoretic light scattering. It was shown that an increase in the proportion of charged amino acids in the composition of a random copolymer leads to an increase in the hydrodynamic diameter of particles in the case of copolymers based on L-lysine; partial replacement of L-serine with D-phenylalanine leads to a decrease in particle size.

## References

- [1] Zhu J., Han H., Li F., Wang X., Yu J., Chu C., Wu D. *J. Coll. Interf. Sci.* **2019**, 22, 634-646
- [2] Grigoreva A., Polozov E., Zaitsev S. *Colloid and Polymer Science* **2019** 297, 1423-1435
- [3] Li L., Raghupathi K., Song C., Prasad P., Thayumanavan S. *Chem. Heterocycl. Chem. Commun.* **2015**, 50, 13417–13432

Acknowledgements. This work was supported by The Russian Science Foundation (project # 20-73-00222).

NOVEL CARBORANE COMPLEXES OF RUTHENIUM IN THE CONTROLLED RADICAL POLYMERIZATION OF METHYL METHACRYLATE BY THE ATRP MECHANISM

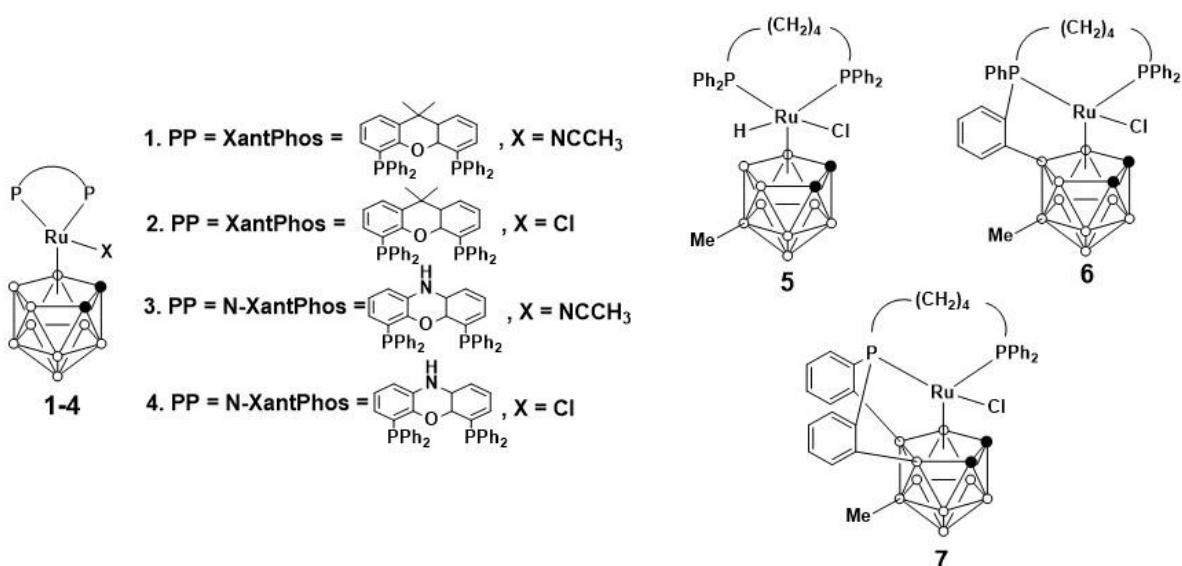
*Knyazeva N.A., Grishin I.D.*

Lobachevsky State University, Nizhny Novgorod, Russia

PhD Student

[knyaseva2012@yandex.ru](mailto:knyaseva2012@yandex.ru)

One of the methods for preparing well-defined homo- and copolymers is Atom Transfer Radical Polymerization (ATRP). This method is based on the use of transition metal complexes as catalysts of polymerization. According to modern theoretical concepts, the activity of a metal complex catalyst in the process under consideration correlates with the value of its redox potential and depends on the donating ability of the ligands included in its structure. In view of the above, the search for new catalysts with higher efficiency under the process conditions should be sought among compounds with donor ligands. As examples of such compounds, one can consider ruthenium carborane complexes containing P-O-P ligands of the XantPhos type in their structure [1], as well as complexes based on the 5-MeC<sub>2</sub>B<sub>8</sub> carborane ligand (1-7).



The results of experiments indicate that all new ruthenacarboranes are capable to act as catalysts for controlled radical polymerization of methyl methacrylate by the ATRP mechanism even when they are used at a concentration of 0.01 mol. %. The process was accompanied by a uniform increase of the molecular weight of the samples with an increase in conversion, and the experimentally obtained number average molecular weights slightly differed from the theoretically calculated ones. The molecular weight distribution curves of polymers were unimodal, and the polydispersity coefficients decreased as the polymerization proceeded. The controlled character of polymerization was confirmed by analysis of the end groups of the obtained polymers by MALDI mass spectrometry.

Experiments have shown that the most effective catalysts among the complexes under consideration were shown by compounds **6** and **7** containing a methyl-substituted carborane ligand and ortho-phenylenecycloborated fragments, which impart high stability to the compounds under the process conditions.

#### References

[1] Grishin I.D., Knyazeva N.A., Penkal' A.M. *Russian Chemical Bulletin* **2020**, 69, 1520–1529

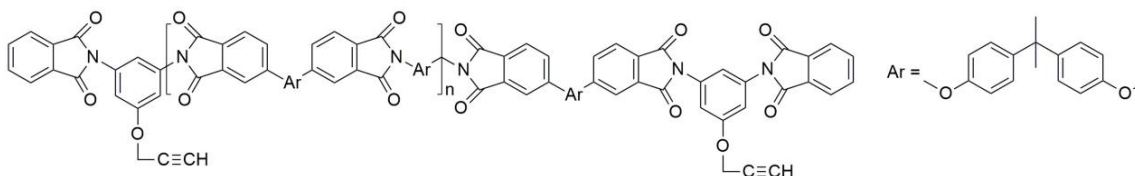
Acknowledgements. This work was supported by the Russian Science Foundation (project No 18-73-10092).

## DEVELOPMENT OF NEW THERMOSETTING OLIGOIMIDES WITH PROPARGYL SIDE GROUPS

*Kolesnikov T.I.*<sup>1</sup>, *Tsegelskaya A.Y.*<sup>1</sup> *Kuznetsov A.A.*<sup>1</sup>

<sup>1</sup>Enikolopov Institute of Synthetic Polymeric Materials RAS, Moscow, Russia  
PhD Student  
kolesnikov@ispm.ru

In the previous years the position of PMC (Polymer Matrix Composites), which was already strong, has been highly improved. They are a unique group of materials often applied in the automotive, aerospace, marine and military industry. PCM is much lighter than traditional materials, have good mechanical properties, good corrosion resistance, extremely good formability and damping of mechanical vibrations. In the automotive industry, the relative high specific strength of PMC makes possible the reduction of weight of final elements of car structures. The same tendency is observed as well in the aerospace industry. In this regard, the important task is to find new polymer binders that will be suitable for work in a wide range of temperatures, have good mechanical properties, chemical resistance and high processability of processing.



**Figure 1.** Structure of oligoimides.

A series of thermoplastic oligoimides with a propargyl substituent in the side chain was synthesized by the new environmental-friendly method of high-temperature catalytic co-polycondensation in the melt of benzoic acid [1]. High-molecular compounds based on the new monomer - 5-(2-propyn-1-yloxy) benzene-1,3-diamine was observed. Oligoimides showed good solubility (>20wt% in N-methyl-2-pyrrolidone), wide temperature processing window (>50°C) and also flow well at 220°C. These imide oligomers were successfully converted to cross-linked structures after cross-linking at 300°C. Cross-linked oligomers have a temperature of 5% weight loss >500°C, T<sub>g</sub> >200°C and good mechanical properties (Young modulus = 1671MPa) [2]. The binders developed in this work have the potential to be used in the transport, military and aerospace industries as a matrix for PCM.

### References

[1] Kuznetsov A.A. *High. Perf. Pol.* **2000**, 12, 445

Acknowledgements. This work was supported by Russian Foundation for Basic Research (project No 19-03-00820).

## SCAFFOLDS FOR TISSUE ENGINEERING BASED ON GELATIN-METHACRYLATE PARTICLES

*Krivovicheva V.S.<sup>1</sup>, Averianov I.V.<sup>2</sup>, Krylova M.S.<sup>1</sup>, Sharoyko V.V.<sup>1</sup>, Korzhikov-Vlakh V.A.<sup>1</sup>*

<sup>1</sup>Saint Petersburg State University, Saint Petersburg, Russia

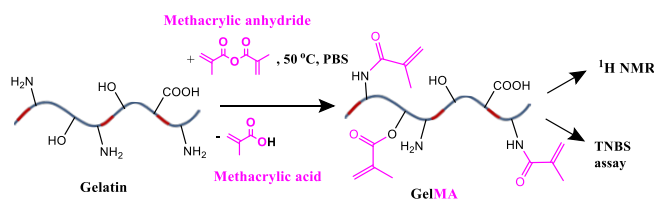
<sup>2</sup>Institute of Macromolecular Compounds RAS, Saint Petersburg, Russia

Student

[vkrivovicheva@mail.ru](mailto:vkrivovicheva@mail.ru)

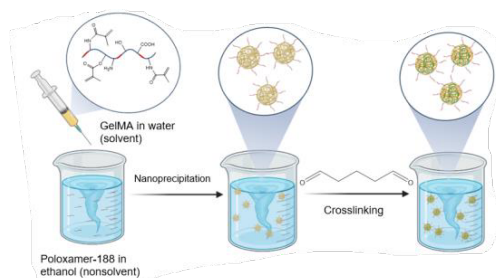
The main goal of tissue engineering is regeneration of damaged tissues using the patient's autogenous cells. Thus, it represents a promising alternative for treatment with application of donor tissues and organs. The main approach implemented in this field is the use of patient autologous cells placed on special scaffolds to obtain viable patient tissues *in vitro* or *in vivo*. Creation of materials with the possibility for spatial distribution of factors affecting such processes as adhesion, differentiation and vascularization is an actual issue, which limit the wide application of tissue engineering in clinic. In these connection, utilization of particles as "ink" for 3D-printing of gradient materials represents a promising strategy. This approach allows to combine particles of various nature and size to form scaffolds of next generation with tunable mechanical properties, pore space topology, and distribution of biological molecules.

Gelatin is one of the polymers, which is interesting for formation of above-mentioned particles based "ink". The presented study is devoted to the preparation gelatin-based particles, which could be used for 3D-printing. To impart gelatin with the ability to photo-cure, it was modified with methacrylate groups. Gelatin Methacrylate (GelMA) was synthesized by reaction of gelatin with methacrylic anhydride and characterized using <sup>1</sup>H NMR and a 2,4,6-Trinitrobenzene Sulfonic Acid (TNBS) assay (Fig.1). The degree of modification was 53-64%.



**Figure 1.** GelMA synthesis and characterization

Nanoparticles based on GelMA were obtained by optimized nanoprecipitation method (Fig. 2). The obtained particles possess hydrodynamic diameter from 256 to 465 nm. Zeta-potential for those was negative and ranged from -31.9 to -16.0 mV. According to the transmission electron microscopy data it was found that obtained nanoparticles are spherical.



**Figure 2.** Schematic illustration of nanoprecipitation technique for the formation of GelMA nanoparticles

The methodology for 3D-printing of scaffolding materials with application of obtained particles and photo-crosslinking was developed. We have demonstrated that successful 3D-printing with particles suspensions requires employment of polymeric cross-linkers, such as PEG-diacrylate or soluble GelMA. The obtained scaffolds were tested for cell adhesion. The obtained results showed good attachment of cells and formation of focal contacts.

**Acknowledgements.** The study was financially supported by Megagrant of Russian Government (agreement # № 14.W03.31.0014). The authors are grateful to Chemical Analysis and Materials, Magnetic Resonance, Geomodel and Centre for Molecular and Cell Technologies Research Centres of Research park of SPbU.

NOVEL PERVAPORATION MEMBRANES MODIFIED BY TITANIUM DIOXIDE FOR PERVAPORATION  
SEPARATION OF VARIOUS INDUSTRIALLY SIGNIFICANT MIXTURES

*Kuzminova A.I.<sup>1</sup>, Penkova A.V.<sup>1</sup>*

<sup>1</sup>Saint Petersburg State University, Saint Petersburg, Russia  
Researcher  
ai.kuzminova@mail.ru

Pervaporation is one of the most popular membrane processes that allows the separation of low molecular weight components, including isomer mixtures, azeotropic mixtures, and thermally unstable mixtures. The rapid development of pervaporation requires the search for novel membrane materials with desired properties. One of the effective methods for improving the transport properties of pervaporation membranes is the development of the mixed – matrix membranes (MMMs). The development of MMMs consists in modifying the polymer matrix by introducing an inorganic filler that leads to getting tailoring properties. MMMs combine the simplicity of processing polymer membranes with the superior transport properties of inorganic particles.

Titanium dioxide (TiO<sub>2</sub>) is the perspective modifier for pervaporation membranes, due to its chemical and thermal stability, low cost, high reusability, and excellent yield in the degradation of organic pollutants. In the present work the novel membranes based on polyphenylene isophthalamide (PA) and polyacrylonitrile (PAN) modified by nanoparticles TiO<sub>2</sub> were developed. The improvement of the transport properties of polymer membranes occurs due to the properties of TiO<sub>2</sub>. The developed polymer/TiO<sub>2</sub> membranes were studied using Fourier-transform infrared spectroscopy, and nuclear magnetic resonance, scanning electron microscopy, atomic force microscopy, X-ray diffraction analysis, thermogravimetric analysis, contact angle and swelling experiments. The transport properties of the developed membranes were studied by pervaporation separation of the various industrially significant mixtures: for membranes based on PA in pervaporation methanol/toluene mixture and for membranes based on PAN in pervaporation water/isopropanol mixture. The introduction of TiO<sub>2</sub> into the polymer matrix leads to significant changes in properties of membranes based on polyphenylene isophthalamide (PA) and polyacrylonitrile (PAN).

Acknowledgements. The reported study was funded by RFBR, Sirius University of Science and Technology, JSC Russian Railways and Educational Fund “Talent and success”, project number 20-38-51022. The experimental work of this study was facilitated by the equipment from the Resource Centre of Geomodel, Chemical Analysis and Materials Research Centre, Centre for X-ray Diffraction Methods, Magnetic Resonance Research Centre, Centre for Innovative Technologies of Composite Nanomaterials, Nanophotonics Centre, Cryogenic department, Thermogravimetric and Calorimetric Research Centre and the Interdisciplinary Resource Centre for Nanotechnology at the St. Petersburg State University.

## POROUS POLYELECTROLYTE CRYOGEL: SYNTHESIS AND ELECTRO SURFACE PROPERTIES

*Laishevkina S.G., Shevchenko N.N.*

Institute of macromolecule compounds, RAS, Saint Petersburg, Russia  
PhD Student  
s.laishevkina@gmail.com

Porous polyelectrolyte materials are widely used in different fields of science and industries. On the one hand the developed specific surface area and an increase in the diffusion rate of the analyzed molecules are determined by the porous gel structure. On the other hand, the presence of ionogenic functional groups broadens the possibilities for gel modification, for example, with electroconductive polymers, such as poly(3,4-ethylenedioxythiophene) (PEDOT). To the best of our knowledge, the presence of ionogenic functional groups, such as sulfo groups, can do both to improve an interaction between electroconductive and isolating materials, and to enhance ionic conductivity. Therefore, high concentration of sulfo groups in polyelectrolyte gels can provide better modification of such gels with PEDOT and the porous structure can improve efficiency of the resulting device.

Hence, in this work porous polyelectrolyte gels based on various polyelectrolyte, such as anionic (poly(sodium p-styrenesulfonate), poly(potassium 3-sulfopropyl methacrylate)) and zwitterionic one (poly(sulfobetaine methacrylate)) were obtained. Crosslinking is provided by using varying concentrations and nature of cross-linked agents (methylene bis acrylamide or ethylene glycol dimethacrylate). Gels were obtained at negative temperatures: -20°C and -196°C. Moreover, the structure, swelling ability and concentration of functional groups of obtained cryogels were investigated.

Acknowledgements. The reported study was funded by RFBR (project number 20-33-90138).

POLYMER ANALOGOUS TRANSFORMATIONS OF NEW SOLUBLE  
HIGH-MOLECULAR DERIVATIVES OF POLYANILINES

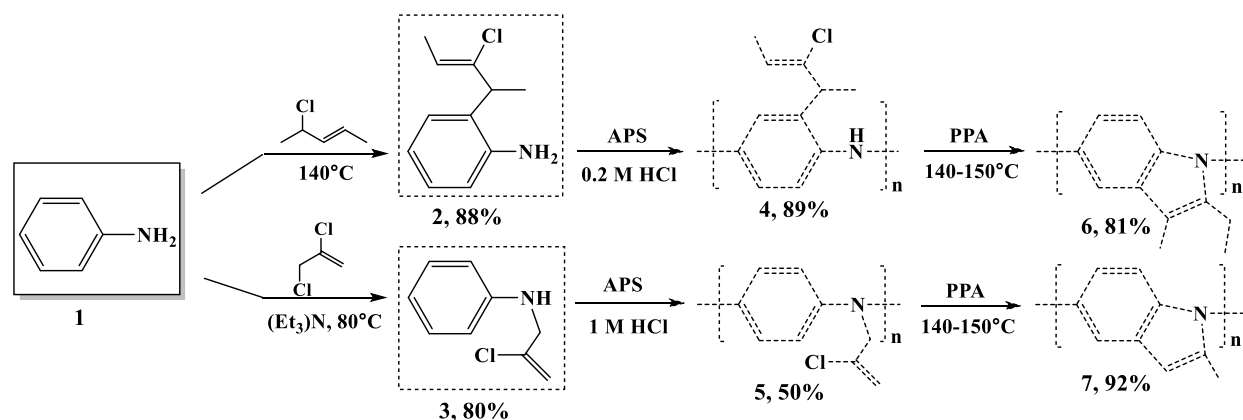
*Latypova L.R., Usmanova G.S., Mustafin A.G.*

Ufa Institute of Chemistry of the Russian Academy of Sciences, Ufa, Russia  
Junior researchert

[Les06091991@yandex.ru](mailto:Les06091991@yandex.ru)

Polyaniline (PANI) is among the most famous representatives of the class of electrically conductive polymers due to its good chemical and environmental stability, ease of the synthesis, availability, low cost of the monomer, etc. Besides, polyaniline has attracted great deal of attention in the past two decades because of its potential applications in various fields such as electronic material, gas sensor, adsorbent of pollutant of water, and pH sensor.[1-2]. However, PANI also has some disadvantages that can be partially or completely eliminated in the process of its modification.

We have found for the first time that heating polyaniline derivatives **4** and **5**, synthesized by oxidative polymerization in the presence of hydrochloric acid using  $(\text{NH}_4)_2\text{S}_2\text{O}_8$  as an oxidizing agent [3], in polyphosphoric acid (PPA) at  $150^\circ\text{C}$  leads to the corresponding polyindoles **6** and **7** in high yields.



**Figure 1.** Synthesis of polymers **4**, **5**, **6** and **7**.

The structures and composition of the polymers that we synthesized were confirmed by elemental analysis, proton nuclear magnetic resonance ( $^1\text{H}$  NMR) spectroscopy, carbon nuclear magnetic resonance ( $^{13}\text{C}$  NMR) spectroscopy, Fourier-transform infrared spectroscopy (FT-IR), and ultraviolet-visible spectroscopy (UV).

#### References

- [1] Mustafin A.G., Latypova L.R., Andriianova A.N., Mullagaliev I.N., Salikhov Sh.M., Salikhov R.B., Usmanova G.S. *RCS Adv.* **2021**
- [2] Andriianova A.N., Biglova Y.N., Mustafin A.G. *RSC Adv.* **2020**, 10, 7468-7491
- [3] Latypova L.R., Andriianova A.N., Salikhov S.M., Mullagaliev I.N., Salikhov R.B., Abdrakhmanov I.B., Mustafin A.G. *Polym. Int.* **2020**, 69, 804-812

This work was supported by the Ministry of Science and Higher Education of the Russian Federation as part of the state task no. AAAA-A19-119020890014-7.

# RAFT COPOLYMERIZATION OF N-VINYLPYRROLIDONE AND FLUOROACRYLATES WITH VARIOUS STRUCTURES

*Lebedev O.A.<sup>1</sup>, Grigoreva A.O.<sup>1</sup>, Zaitsev S.D.<sup>1</sup>*

<sup>1</sup>Lobachevsky State University of Nizhny Novgorod, Nizhny Novgorod, Russia  
Student

[Belved2014@ya.ru](mailto:Belved2014@ya.ru)

One of the tasks of the science of polymers is to control their properties by controlling the processes of formation of macromolecules. Controlled radical polymerization methods play an important role here. They show high efficiency in creating materials with desired properties. Among the most convenient methods, one can distinguish pseudo-living radical polymerization with reversible chain transfer (RAFT polymerization). The advantages of this method are the tolerance of the compounds used to functional monomers, wide possibilities for obtaining macromolecules of complex architecture, and rather mild conditions for their synthesis [1].

Interest in the study of fluorinated polymers is due to their ability to significantly improve the properties of coatings used in modern products. Fluorinated polymers have high chemical resistance, low surface energy, coefficient of friction and refractive index. N-vinylpyrrolidone (NVP) is a stable, hydrophilic compound that shows good biocompatibility [2]. Based on these properties, NVP is excellent for use as a second component of copolymers. This type of copolymer includes positive properties from both fluoropolymers (low surface energy) and N-vinylpyrrolidone polymers (non-toxic).

One of the main applications of such copolymers can be the creation of coatings with low surface energy (hydrophobic) with a slippery surface that prevents fouling.

It can be expected that the resulting copolymers will exhibit amphiphilicity and improved self-organization due to the presence of hydrophobic and hydrophilic units.

The aim of this work is to study the features of RAFT copolymerization of 1,1,1,3,3,3-hexafluoroisopropyl acrylate (HFIPA) and NVP; 2,2,3,3,4,4,5,5-octafluoropentyl acrylate (OFPA) and NVP. In addition to copolymerization in the presence of a low molecular weight reversible chain transfer agent BTC (dibenzyl trithiocarbonate), copolymerization in the presence of high molecular weight RAFT agents based on PHFIPA and POFPA was studied. Another important task is to obtain curves of the composition of copolymers, to calculate the relative activities of monomers using the Fineman-Ross and Kelen-Tudosh methods [3], and to study surface pressure isotherms.

## References

- [1] Chernikova E.V., Sivtsov E.V. *Polymer Science, Series B* **2017**, *59*, 117–146
- [2] Liu X., Xu Y., Wu Z., Chen H. *Macromolar Bioscience* **2013**, *13*, 147-154
- [3] Kelen T., Tudos F. *Macromol. Sci. Chem.* **1975**, *9*, 1-27

Acknowledgements. This work was supported by the Russian Foundation for Basic Research (project No 19-03-00843).



NOVEL MEMBRANES BASED ON HYDROXYETHYL CELLULOSE  
FOR ENHANCED PERVAPORATION DEHYDRATION

*Liamin V.P.<sup>1</sup>, Dmitrenko M.E.<sup>1</sup>, Zolotarev A.A.<sup>1</sup>, Penkova A.V.<sup>1</sup>*

<sup>1</sup>Saint Petersburg State University, Saint Petersburg, Russia  
Student

[lyaimin.vlad.322@gmail.com](mailto:lyaimin.vlad.322@gmail.com)

Currently, the development of membrane technologies related to sustainable processes is an extremely important area due to their active use in industry for the separation of gas and liquid mixtures. One of the most promising membrane methods for separating of liquid mixtures of low molecular weight substances is pervaporation. This method is widely used for the separation of close-boiling substances, isomer and azeotropic mixtures. But the most important pervaporation application is the dehydration of organic solvents, in particular, alcohols. The rapid development of the pervaporation requires the search and creation of novel high performance membranes with tailored properties to increase the efficiency of the separation process. One of the most successful and simple ways to create membranes with specified transport characteristics is blending of different polymers in matrix.

The aim of this work was to develop new highly efficient pervaporation membranes based on hydroxyethyl cellulose (HEC) for the dehydration of organic solvents. The improvement of the transport characteristics of HEC membranes was achieved by blending with other hydrophilic polymers (sodium alginate (SA) or polyvinyl alcohol (PVA)) and the volume (bulk) modification of blend with water-soluble fullerene derivatives. The structure of the composites and the developed membranes was studied by various analysis methods (spectroscopic and microscopic). The physicochemical properties of the obtained membranes were analyzed by the sorption experiments and the measurements of contact angle. The transport characteristics of the HEC-based membranes were evaluated in pervaporation dehydration of isopropyl alcohol in a wide concentration range. It was demonstrated that blend HEC-based membranes had improved transport characteristics compared to membranes based on pristine polymers, and their modification with water-soluble fullerene derivatives led to the increased permeability.

**Acknowledgements.** This work was supported by Russian Science Foundation [project No 20-79-10064]. The experimental work was facilitated by equipment from the Resource Centers for Nanotechnology, Magnetic Resonance, X-ray Diffraction Studies, Thermogravimetric and Calorimetric Research Centre, Chemical Analysis and Materials Research Centre, Cryogenic Department, and Centre “Nanofabrication of Photoactive Materials (Nanophotonics)” at the St. Petersburg State University.

## THERMAL STABILITY OF PHTHALONITRILE-BASED RESINS

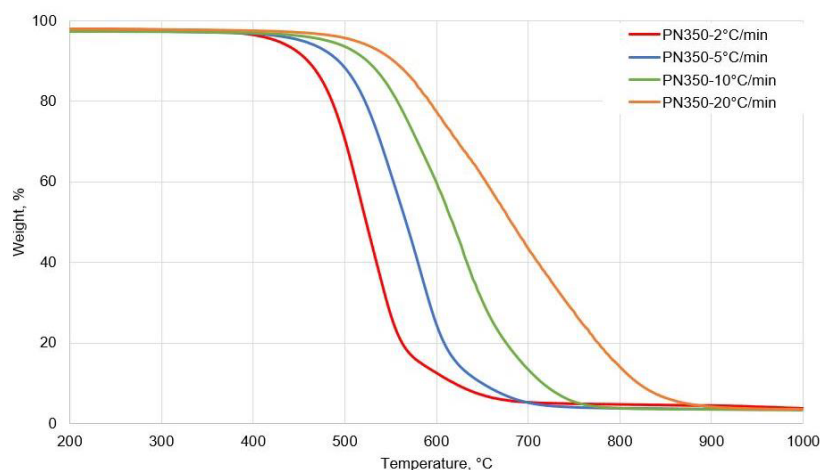
*Lobanova M.S.<sup>1</sup>, Bulgakov B.A.<sup>1</sup>*

<sup>1</sup>Moscow State University, Moscow, Russia  
PhD student  
[lobanovams8@gmail.com](mailto:lobanovams8@gmail.com)

Phthalonitrile-based materials are promising materials for elevated temperature (over 300°C) operation purposes. Their thermal properties can be improved by studying thermal oxidation kinetics parameters and mechanisms. Thus, in this research the thermal oxidation process of low-melting phthalonitrile resins is investigated [1-2].

To study the oxidation kinetics, phthalonitrile resins (post-cured at 330°C, 350°C, 375°C) were measured in non-isothermal mode by thermogravimetric analysis (TGA) at different heating rates (2–20°C/min) in flowing air (Figure 1). Also, isothermal kinetics was undertaken, corresponding to periodic weighing of samples after various exposure times at temperatures in the range of 280°C to 350°C for up to 200 h in an oven. The results showed that there were four overlapping stages in the thermal oxidation process. Kinetics parameters of each stage were calculated in Netzsch Thermokinetics. Based on these parameters the most probable kinetic mechanisms were determined.

The influence of thermal oxidation was also estimated by the change of sample appearance (cracking), flexural strength, glass transition temperature of studied phthalonitrile resins after various exposure times at elevated temperature (280°C–350°C).



**Figure 1.** TGA curves of thermal oxidation of phthalonitrile resin post-cured at 350°C at constant linear heating rates of 2°C/min, 5°C/min, 10°C/min and 20°C/min

### References

- [1] Bulgakov B.A. et al. *Polymer Science*. **2021**, 63, 54–94  
[2] Liang B. et al. *Thermochim Acta* **2019**, 672, 133-141

**Acknowledgements.** This work was carried out in the framework of the state assignment of the Department of Chemistry of the M. V. Lomonosov Moscow State University. Project No AAAA-A21-121011590086-0.

This research was performed according to the Development program of the Interdisciplinary Scientific and Educational School of Lomonosov Moscow State University «The future of the planet and global environmental change».

NEW METHOD FOR CONTROLLED SYNTHESIS OF PLA BLOCK-COPOLYMERS:  
ORGANOBORANE/*p*-QUINONE SYSTEM AND REVERSIBLE-DEACTIVATION RADICAL POLYMERIZATION

*Ludin D.V.*<sup>1</sup>, *Zaitsev S.D.*<sup>2</sup>, *Fedushkin I.L.*<sup>1,3</sup>

<sup>1</sup>Minin University, Nizhny Novgorod, Russia

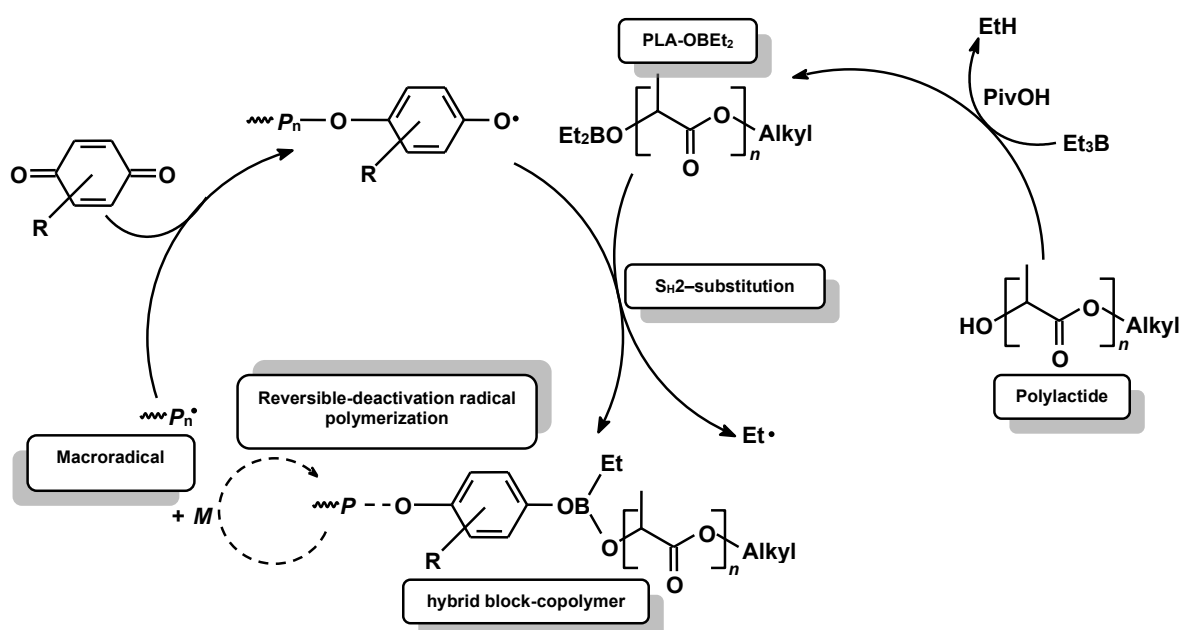
<sup>2</sup>Lobachevsky State University of Nizhny Novgorod, Nizhny Novgorod, Russia

<sup>3</sup>Razuvaev Institute of Organometallic Chemistry, Nizhny Novgorod, Russia

PhD in chemistry

[dymass@rambler.ru](mailto:dymass@rambler.ru)

Poly lactide (PLA) is one of the most modern and ambitious biomedical polymeric material. Owing biocompatibility and biodegradability as well as excellent reconcilability with human tissues PLA based materials obtain the ever wide use. Since mechanical and physical properties of PLA are well compared with those of synthetic polymers, PLA and its copolymers are an ecological alternative to plastics made from petrochemical raw materials One of the most useful approaches for modification of PLA is reversible-deactivation radical polymerization (RDRP).



**Figure 1.** PLA-*block*-poly(vinyl monomer) synthesis in the presence of Et<sub>3</sub>B and *p*-quinones.

In this work, we developed the new approach to obtain PLA hybrid block-copolymers with vinyl monomers (styrene, methyl methacrylate, methyl acrylate) through the realization of the reaction sequence using triethylborane and various *p*-quinones (Fig. 1). The method offered includes two stages. At the first stage, a chain-transfer agent was obtained by borylation the terminal hydroxyl groups of poly lactide. The second stage was vinyl monomer radical polymerization in the presence of *p*-quinone accompanied by the S<sub>H2</sub>-substitution at the boron atom. 1,4-Naphthoquinone, 2,3-dimethyl-1,4-benzoquinone, duroquinone, 2,5-di-*tert*-butyl-1,4-benzoquinone were used as synthetic polymer chain growth mediators. It has been shown that 1,4-naphthoquinone and 2,3-dimethyl-benzoquinone-1,4, similar in their characteristics, are effective agents providing the realization of reversible-deactivation radical polymerization. Realization of reversible-deactivation radical polymerization process was proved while analyzing the kinetics of block copolymerization, molecular-weight characteristics and compositional homogeneity of block-copolymers as well as its further capability to elongate the polymer chain. Synthesized block-copolymers have a high thermal stability compared to the initial borylated poly lactide.

Acknowledgements. This work was supported by Ministry of Science and Higher Education of the Russian Federation (Reg. No. AAAA-A20-120092990108-5).

STUDY OF SORPTION CHARACTERISTICS OF COLLAGEN-ACRYLIC HYDROGEL  
UNDER THE CONDITIONS OF INFLAMMATION PHASE

*Luneva O.V.,<sup>1</sup> Fateev A.D.,<sup>1</sup> Kudryavtseva T.S.,<sup>1</sup> Kashurin A.I.,<sup>1</sup> Uspenskaya M.V.<sup>1</sup>*

<sup>1</sup>ITMO University, Saint Petersburg, Russia

E-mail: [ovlunevaitmo@gmail.com](mailto:ovlunevaitmo@gmail.com)

Healthy human skin has a slightly acidic pH in the range from 4.0 to 6.0, which in turn performs the barrier function of the skin - regulates the bacterial flora and prevents the penetration of infections. The formation of a wound leads to a violation of the acidic environment of the skin, which raises its pH to neutral values (pH = 7.4).

In present work, the sorption properties of collagen-acrylic hydrogels under conditions close to the pH of the wound were investigated. The samples were obtained by free radical polymerization with various prescription (degree of neutralization of acrylic acid = 60, 70, 80, 90, 100%) and technological parameters (synthesis temperature = 20, 25, 30, 35, 40, 45 ° C). The study of sorption properties was carried out in a phosphate-buffered saline solution (pH = 7.2-7.6). To describe the sorption regularities of the obtained hydrogel materials, a pseudo-second order equation and Fick's mathematical model were used.

$\alpha$ , %	$k_2 \cdot 10^3$ , (g/(mmol·min))	n	k, min <sup>-1</sup>	$Q_{max}$ , g/g	T, °C	$k_2 \cdot 10^3$ , (g/(mmol·min))	n	k, min <sup>-1</sup>	$Q_{max}$ , g/g
60	0,8	0,4	0,06	8,9	20	0,9	0,3	0,1	11,1
70	0,75	0,4	0,06	9,1	25	1,6	0,2	0,2	10,5
80	0,74	0,3	0,09	11,6	30	0,8	0,2	0,15	11,6
90	0,9	0,3	0,11	11,3	35	1,4	0,3	0,16	11,2
100	1,39	0,2	0,14	10,0	40	0,6	0,3	0,1	13,0
					45	1,0	0,3	0,15	11,0

**Table 1.** Kinetic characteristics of samples in phosphate-buffered saline (pH = 7.2-7.6) at different degrees of neutralization of Acrylic acid ( $\alpha$ ) and synthesis temperature (T);

Samples with a degree of neutralization of 80% at 40 ° C show the best degree of swelling in phosphate buffered saline (pH = 7.2-7.6) - 11.6 and 13.0 g / g, respectively (Table 1). The kinetic equation of the pseudo second order shows the diffusion rate of a molecule with a mass equal to the primary mass of the polymer structure [2]. Based on this, the more equation constants are obtained, the diffusion rate is higher (Table 1).

The Fick equation constant characterizes the rate of sorption of the system at the initial stages of swelling (up to  $Q = 0.6Q_{max}$ ). Analyzing the relative rates of diffusion and relaxation of the polymer structure in terms of the power exponent, we can draw a conclusion on the type of diffusion [3].

It was shown that for the obtained hydrogel collagen-containing samples: 1) with an increase in the degree of neutralization of acrylic acid, the values of n are equal to 0.4, 0.4, 0.3, 0.3, 0.2; 2) with an increase in the synthesis temperature, the values of n are 0.3, 0.2, 0.2, 0.3, 0.3, 0.3. These values correspond to the state when the rate of solvent diffusion is much lower than the relaxation rate of the polymer chain.

#### References

- [1] Gupta N. V., Shivakumar H. G. Iranian journal of pharmaceutical research: IJPR. – 2012. – T. 11. – №. 2. – C. 481.  
 [2] Ganji F., Vasheghani F. S., Vasheghani F. E. – 2010.  
 [3] Gierszewska-Drużyńska M., Ostrowska-Czubenko J. Progress on Chemistry and Application of Chitin and its Derivatives. – 2012. – T. 17. – C. 63-70.

## BONE SUBSTITUTION MATERIALS BASED ON POLYMERS WITH CONTROLLED RELEASE OF PHYSIOLOGICALLY ACTIVE SUBSTANCES

*Luss A.L.<sup>1</sup>, Kushnerev K.S.<sup>1</sup>, Chumakova A.S.<sup>1</sup>, Vlaskina E.R.<sup>1</sup>, Seregina T.S.<sup>1,2</sup>, Zaitsev V.V.<sup>2</sup>, Dyatlov V.A.<sup>1,3</sup>*

<sup>1</sup>Mendeleev University of Chemical Technology of Russia, Moscow, Russia

<sup>2</sup>N.N. Proirova National Medical Research Center of Traumatology and Orthopedics, Moscow, Russia

<sup>3</sup>MIREA—Russian Technological University, Moscow, Russia

Young scientist

[al.luss@yandex.ru](mailto:al.luss@yandex.ru)

The practice of using tissue-substituting materials has determined the main directions for the development of methods for chemical processing of various biological tissues before using them as the basis for biological prostheses for a wide variety of purposes.

Recent studies have shown that the treatment of bone defects requires the local application of various drugs, which must be administered according to their own «program» without other substances.

The aim of this study is to create new polymeric materials suitable for the treatment of bone injuries. The main idea of multimodal production of drugs from a prosthesis is to create a polymer biocomposite material containing biologically active substances associated with the prosthesis in two different ways. The first method consists in chemically combining a polymer material with a prosthesis using a hydrolysable bond. The second is the immobilization of the drug due to the non-hydrolysable covalent bond, while the diffusion of the drug occurs during the biodegradation of the polymer carrier.

To accomplish the first task, dialdehyde polysaccharides were used, which were obtained from components of blood substitutes based on dextran and carboxymethyl cellulose using Malaprad by periodate oxidation. Water-soluble collagen, insulin, and the aminoglycoside antibiotic amikacin were chemically attached to the resulting polymers. The effect of slowing down the biodegradation of collagen was found during its chemical modification with polysaccharide residues. Thus, new biocomposite materials containing physiologically active polymers, fillers, and antibiotics were obtained.

The second problem was solved by using biodegradable polysaccharide gels consisting of hydroxyethyl starch and hydroxyethyl cellulose containing the antibiotic amikacin applied to a matrix washed from bovine bones. It was shown that the product of antibiotic immobilization on a modified polysaccharide cannot be hydrolyzed in the absence of enzymes by releasing antibiotic glycosides with antibacterial activity.

The proposed approach makes it possible to create biocomposite materials capable of releasing various substances required at stage after the surgery operation, and each substance is released at its own time and according to its own «program».

## INTRODUCTION OF PHENYLBORONIC ACIDS IN ORGANOSILICON COMPOUNDS

*Manokhina E.A.*<sup>1</sup>, *Anisimov A.A.*<sup>1</sup>, *Drozdov F.A.*<sup>2</sup>, *Peregudov A.S.*<sup>1</sup>, *Muzafarov A.M.*<sup>1,2</sup>

<sup>1</sup>Institute of Organoelement Compounds Russian Academy of Sciences, Moscow, Russia

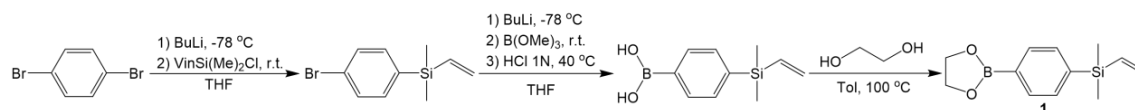
<sup>2</sup>Institute of Synthetic Polymeric Materials Russian Academy of Sciences, Moscow, Russia

Postgraduate student

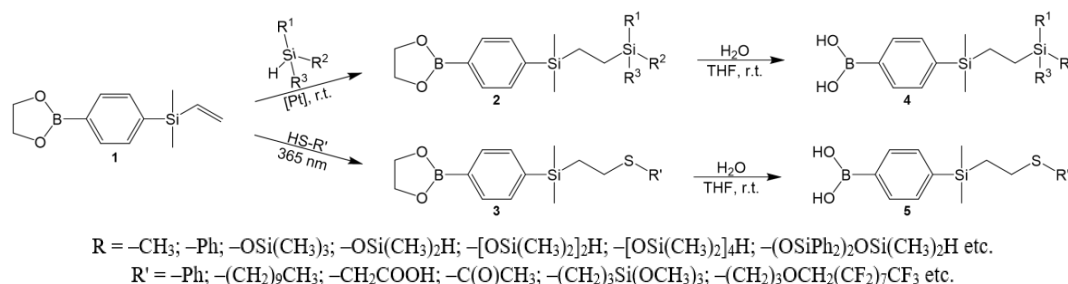
[lizaveta\\_him@mail.ru](mailto:lizaveta_him@mail.ru)

Organic derivatives of boronic acids are widely used as reagents for Suzuki-Miyaura, Petasis, Chan-Lam reactions. The use of boronic acids as building blocks allows the design of self-organizing functional materials. Polyorganosiloxanes are characterized by high flexibility of macromolecules and weak intermolecular interaction. The introduction of various boronic acids into siloxane matrices can lead to an increase in the strength properties of materials based on them due to the formation of both hydrogen and donor-acceptor bonds [1].

We have obtained compound **1** (Figure 1), on the basis of which we carried out the reactions of hydrosilylation **2** and hydrothiolation **3** with various substrates (Figure 2). In this case, the protective group is easily removed with water to form phenylboronic acid derivatives **4** и **5** (Figure 2). The resulting substances were characterized by NMR and IR spectroscopy, mass spectrometry.

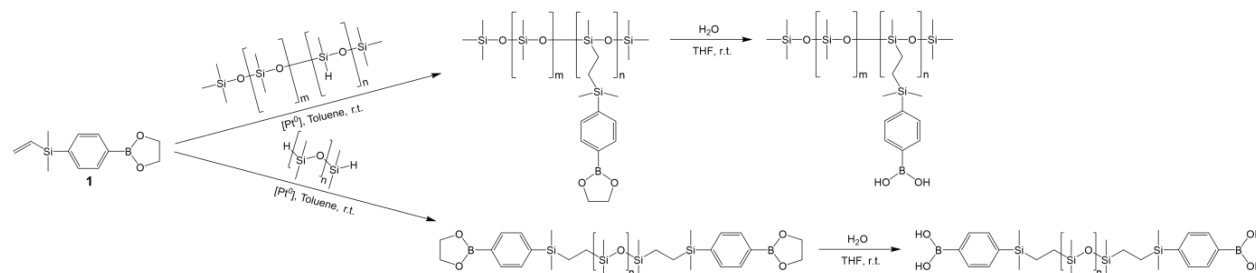


**Figure 1.** Synthesis scheme for modifier **1**.



**Figure 2.** Obtaining new organosilicon derivatives of boronic acids by hydrosilylation and hydrothiolation reactions.

The results of this work served as the basis for the further use of compound **1** for the modification of polyorganosiloxanes with a subsequent reaction of deprotection (Figure 3), which were studied by NMR spectroscopy, GPC, TGA, and DSC.



**Figure 3.** Scheme for the preparation of polyorganosiloxanes (telechelic and pendant) with phenylboronic acid fragments.

It is assumed that this approach will allow the development of new functional materials with unique rheological and self-healing properties.

### References

[1] Anisimov A. A., Drozdov F. V., Vysochinskaya Y. S. et al. *Chemistry - A European Journal* **2020**, *26*, 11404-11407

SYNTHESIS OF POLYSTYRENE TRITHIOCARBONATE AS A PRECURSOR  
FOR BLOCK-COPOLYMER SYNTHESIS BY RAFT-POLYMERIZATION

*Maratkanov A.O.<sup>1</sup>, Bykova P.N.<sup>1</sup>, Gostev A.I.<sup>2</sup>*

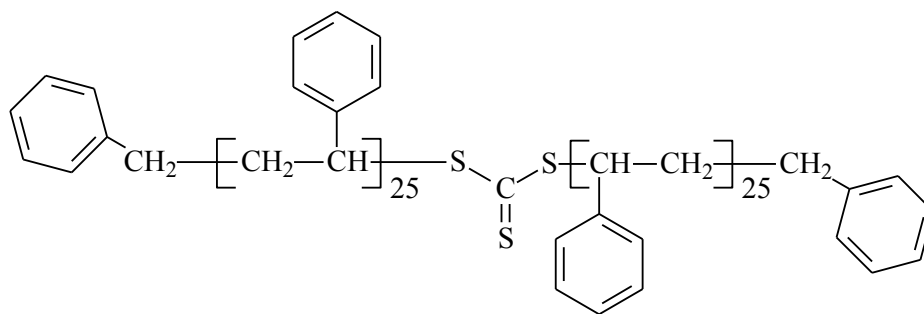
Saint Petersburg State Institute of Technology, Saint Petersburg, Russia

<sup>1</sup>Students, <sup>2</sup>researcher

[artur.maratkanov@mail.ru](mailto:artur.maratkanov@mail.ru)

Present work is the part of a set of studies to investigate influence of microstructure of copolymers on their properties. Development of methods for controlled radical polymerization let the solution possible, in particular, for polymerization with reversible addition - fragmentation chain transfer (RAFT). Further on, the results of syntheses of polystyrene-trithiocarbonate, being a precursor for obtaining block-copolymers of styrene with other monomers, in particular, acrylates, are to be presented.

For successful synthesis of block-copolymers most of the chains of the polymer-precursor need to contain a fragment corresponding to initial low molecular weight RAFT agent (in this case, bisbenzyltrithiocarbonate (BTC), i.e. to be capable for the further chain propagating. For initiation of the process, azobisisobutyronitrile (AIBN) was used. Based on expected degree of polymerization of the polystyrene block of 50 chains, the ratio [monomer]/[BTC] = 50 and, correspondingly, [monomer]/[AIBN] = 10<sup>4</sup> was chosen to minimize the proportion of «dead» chains. The structural formula of the resulting compound, subject to one-hundred percent conversion, is shown in Figure 1.



**Figure 1.** Structural formula of polystyrene-trithiocarbonate, obtained at the conversion of 100%

The results of the synthesis are shown in Table 1. It is obvious that at a given concentration of AIBN, maximum achievable conversion is too low. Based on this fact, polymer samples were obtained at concentrations 5 and 10 times higher (see Table 1). Molecular weights were determined by gel-permeation chromatography (GPC). The data given in the Table show there is good correspondence of obtained MWs to theoretical values.

The data presented in this work indicate that increase in concentration of the initiator (AIBN) above 4.8·10<sup>-3</sup> mol/L does not lead to noticeable increase in conversion, therefore, Sample 2 can be considered optimal for further syntheses.

**Table 1.** Summary table of synthesis results

Sample	[BTC]	[AIBN]	Monomer conversion, %	M <sub>n</sub> theoretical	M <sub>n</sub>	M <sub>w</sub>	M <sub>w</sub> /M <sub>n</sub>
1	0,174	8,7·10 <sup>-4</sup>	24,0	1320	1360	2000	1,5
2		4,8·10 <sup>-3</sup>	60,4	3300	2600	3600	1,4
3		8,7·10 <sup>-3</sup>	62,0	3400	2600	3600	1,4

## BORON-SUBSTITUTED CARBORANE-CARBOSILANE DENDRIMERS: SYNTHESIS AND PROPERTIES

*Minyaylo E.O.*<sup>1</sup>, *Anisimov A.A.*<sup>1</sup>, *Zaitsev A.V.*<sup>1</sup>, *Milenin S.A.*<sup>2</sup>, *Khanin D.A.*<sup>1</sup>, *Ol'shevskaya V. A.*<sup>1</sup>,  
*Nikiforova G.G.*<sup>1</sup>, *Buzin M.I.*<sup>1</sup>, *Peregudov A.S.*<sup>1</sup>, *Muzafarov A.M.*<sup>1,2</sup>

<sup>1</sup>Institute of Organoelement Compounds RAS, Moscow, Russia

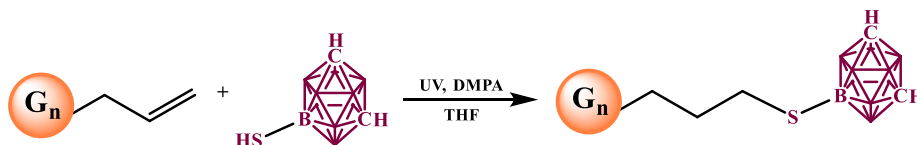
<sup>2</sup> Institute of Synthetic Polymer Materials RAS, Moscow, Russia

Postgraduate student

[ekaminaylo1995@mail.ru](mailto:ekaminaylo1995@mail.ru)

Dendrimers are highly branched regular structures, characterized by nearly-ideal monodispersity and a wide variety of possible functional groups. Currently, studies of the packing problems and of the dependence of the dendrimer properties on the generation number become increasingly important. For this reason, there is an increasing need to develop fast and well-controlled methods for the synthesis of such compounds with hybrid structure. From this point of view, carbosilane dendrimers seem to be ideal frameworks for creating new hybrid structures. One of the current directions associated with the study of this class of compounds is the synthesis of carbosilane dendrimers with various shells and the study of their properties. Dendrimers containing carborane fragments in their structure are of particular interest. This is due to the fact that carborane-containing macromolecules are characterized by unique steric and chemical properties of boron clusters [1], which is confirmed by a significant number of publications [2]. The use of boron-substituted derivatives of polyhedral carboranes can allow one not only to modify the outer layer of a dendrimer without a catalyst but also, to further functionalize -CH groups of the carborane framework.

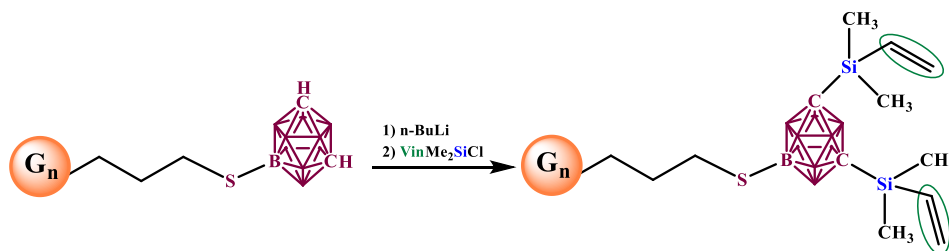
Thus, the purpose of this work was to synthesize new organoelement dendrimers of different generations based on polyallylcarbosilane dendrimers and a boron-substituted mercapto derivative of a polyhedral carborane as models of hybrid dendrimers of «flexible core – rigid shell» type. Carborane-carbosilane dendrimers of the zero ( $G_0$ -4 cages), first ( $G_1$ -8 cages), third ( $G_3$ -32 cages) and fifth ( $G_5$ -128 cages) generations were obtained by hydrothiolation of the corresponding carbosilane dendrimers with 9-mercapto-*m*-carborane (Fig. 1) initiated by UV-irradiation ( $\lambda = 365$  nm) and DMPA at room temperature in THF solution [3].



**Figure 1.** General scheme for the synthesis of carborane-carbosilane dendrimers.

The structures and purity of the compounds obtained were confirmed by using a set of physicochemical methods of analysis:  $^1\text{H}$ ,  $^{29}\text{Si}$ ,  $^{13}\text{C}$  and  $^{11}\text{B}$  NMR, IR spectroscopy, and gel permeation chromatography. Their properties were studied by DSC, TGA, TMA, DLS and viscometry in solution.

Also, within the confines of our work, we have shown the possibility of further functionalization of the carborane framework in boron-substituted carborane-carbosilane dendrimers by lithiation of -CH groups followed by blocking with dimethylvinylchlorosilane (Fig. 2).



**Figure 2.** General scheme for the functionalize -CH groups of the carborane framework.

### References

- [1] R. N. Grimes. *Carboranes*. Sec. Ed., **2011**
- [2] R. Núñez, I. Romero, F. Teixidor, C. Vinas. *Chem. Soc. Rev.* **2016**, 45, 5147–5173
- [3] E.O. Minyaylo, A.A. Anisimov, A.V. Zaitsev, S.A. Milenin, P.A. Tikhonov, O.V. Vyshivannaya, V.A. Ol'shevskaya, G.G. Nikiforova, M.I. Buzin. A.S. Peregudov, A.M. Muzafarov *React. Funct. Polymer.* **2020**, 157, 104746



Acknowledgements. The reported study was funded by RFBR according to the research project № 20-33-90249

## EFFECT OF BLEACHING CONDITIONS ON THE PROPERTIES OF HERBAL CELLULOSE

*Momzyakova K.S., Deberdeev T.R., Aleksandrov A.A., Pechenyi E.A., Nuriev N.K., Yamashev T.A., Kanarsky A.V., Deberdeev R.Ya.*

Kazan National Research Technological University, Kazan, Russia  
Student

[ksunya-fadeeva@yandex.ru](mailto:ksunya-fadeeva@yandex.ru)

One of the most promising bleaching methods is the method of delignification of plant materials with hydrogen peroxide in an acidic medium in the presence of transition metal oxoanions - delignification catalysts. Interest in this approach is due to the low temperature, pressure, and time of the bleaching process, as well as environmental safety compared to standard sulfite and sulfate methods of delignification of cellulose-containing materials [1, 2].

The influence of the conditions of bleaching cellulose from oat and alfalfa straw on their physicochemical and color characteristics was investigated. The processing of cellulose was carried out in two ways, one of which is alkaline processing of cellulose mass, followed by washing and peroxide bleaching in an alkaline medium, and the second is the processing of the pulp with a mixture of hydrogen peroxide and ammonium molybdate in an acidic medium, followed by washing and additional peroxide bleaching in alkaline environment.

Table 1. Physicochemical characteristics of alfalfa and oat cellulose

№	Raw materials	Bleaching method	$\alpha$ -cellulose content, %	Lignin content, %	Resin and fat content, %	Ash content, %	Degree of polymerization	Yield, %	Brightness	Crystallinity index, $I_{cr}$
1	Alfalfa	Unbleached cellulose	84,7	14,5	0,2	5,0	1260	45,0	81	0,77
2		Alkaline treatment+ peroxide bleaching	86,2	11,0	0,1	5,0	800	39,5	92,8	-
3		Peroxide - molybdate bleaching + peroxide bleaching	87,9	0,0	0,0	0,8	350	28,4	95,4	0,81
4	Oat	Unbleached cellulose	76,8	7,0	1,8	5,5	1020	42,0	65,0	0,65
5		Alkaline treatment+ peroxide bleaching	78,0	3,5	0,2	6,3	1080	31,5	88,6	-
6		Peroxide - molybdate bleaching + peroxide bleaching	76,5	<0,0 1	0,3	1,0	500	27,7	92,4	0,77
7	Cotton	-	98,4	-	-	-	1250	-	93,9	0,87

It is shown that both types of bleaching lead to a decrease in the content of lignin, resins and fats, ash, the degree of polymerization, as well as the yield of cellulose obtained from both oats and alfalfa, but an increase in their crystallinity index. At the same time, peroxide-molybdate bleaching of cellulose pulp from oat and alfalfa straw in an acidic medium contributes to a much more intensive extraction of non-cellulosic impurities, in comparison with only peroxide treatment in an alkaline medium, as well as the production of cellulose fibers with a high degree of brightness – 92,4 and 95,4, respectively, comparable to the brightness values for cotton cellulose – 93,9. At the same time, alfalfa cellulose has a relatively high crystallinity index – 0,81 and alpha - cellulose content – 87,9. It is shown that peroxide-molybdate bleaching in an acidic medium helps to reduce the intensity of the red and yellow shades of cellulose in the CIELAB color space.

### References

- [1] Milovidova L.A., Komarova G.V., Koroleva T.A., Pulp bleaching. **2005**, 130.  
[2] Volkova I.Yu., dissertation abstract, **2010**, 18.

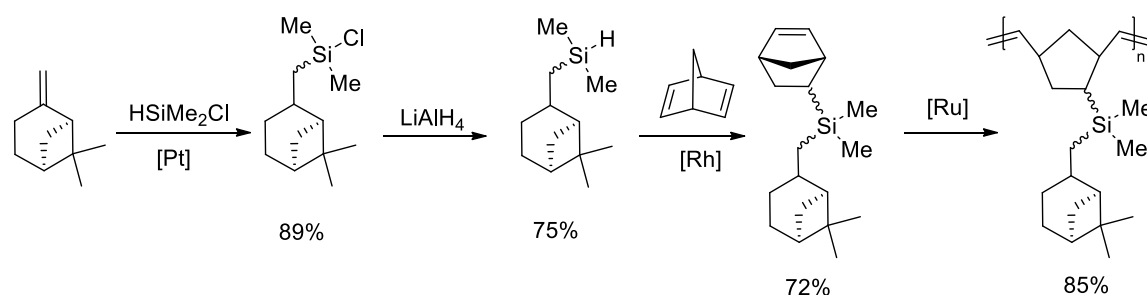
Acknowledgements. This work was supported by the Russian Foundation for Basic Research (project No 18-29-18077).

*Nazarov I.V.<sup>1</sup>, Guseva M.A.<sup>1</sup>, Alentiev D.A.<sup>1</sup>, Bermeshev M.V.<sup>1</sup>.*

<sup>1</sup>A.V. Topchiev Institute of Petrochemical Synthesis RAS, Moscow, Russia  
Ph.D Student  
[vanyanaz@ya.ru](mailto:vanyanaz@ya.ru)

At present, there are many ways to separate optically active compounds such as: HPLC with chiral stationary phase, enzymatic cleavage and others. Our goal was to study the possibility of separating optically active compounds using membranes. The separation of enantiomers using membranes is of interest as a poorly studied method at present. This method allows separating optically active compounds without the usage of organic solvents. This is an important advantage of this method at the present time [1, 2].

Silicon-substituted polynorbornenes have proven to be effective gas separation materials [3,4]. In this study, we synthesized a new optically active Si-substituted polynorbornene (Fig. 1). This type of polynorbornene contained optical pure (-)-β-pinanyl moieties which gave great opportunities for chiral resolution. We synthesized the desired polymer according to four stages with a good yield.



**Figure 1.** Synthesis of Si-substituted polynorbornene

We studied the membrane separation of various racemates such as tryptophan, phenylalanine, ibuprofen, butanol-2, butanediol 1,3 and others by polymer the synthesized. Two methods were applied for the separation of enantiomers: concentration driven permeation and pervaporation. In the case of separation of the aqua racemic solution of tryptophan, over 80% of enantiomeric excess was achieved.

#### References

- [1] Weng X., Baez J.E., et al. *Angew Chemie - Int Ed* **2015**; 54: 11214–11218.  
[2] Shen J, Okamoto Y. *Chem Rev* **2016**; 116: 1094–1138.  
[3] Alentiev D.A., Egorova E.S., et al. *Polym Eng Sci* **2019**; 59: 2502–2507.  
[4] Aoki T., Ohshima M., et al. *Polymer (Guildf)* **1997**; 38: 235–238.

Acknowledgements. This work was supported by Russian Science Foundation (grant no. 20-13-00428).

# THERMORESPONSIVE PROPERTIES OF POLYMETHACRYLATE MOLECULAR BRUSHES WITH OLIGO(ETHYLENE GLYCOL)-BLOCK-OLIGO(PROPYLENE GLYCOL) SIDE CHAINS

Simonova M.A.<sup>1</sup>, *Nepomnyashaya M.I.*<sup>2</sup>, D.M Kamorin<sup>3,4</sup>, O.A Kazantsev<sup>3,4</sup>

<sup>1</sup>Institute of Macromolecular Compounds of the Russian Academy of Sciences, Saint Petersburg, Russia  
<sup>2</sup>Saint-Petersburg state university of industrial technologies and design High School of technology and power engineering, Russia  
Student

<sup>3</sup>Nizhny Novgorod State Technical University n.a. R.E. Alekseev, Nizhny Novgorod, Russia

<sup>4</sup>Department of Organic Chemistry, Lobachevsky State University of Nizhny Novgorod, Nizhny Novgorod, Russia  
[mariasimonova1983@mail.ru](mailto:mariasimonova1983@mail.ru)

Polymer micelles formed by amphiphilic block copolymers, molecular brushes with side chains of block structure form stable monomolecular micelles of cylindrical shape which do not break up under very strong dilution. This is very important for their use in drug delivery. The aim of present work is to study new homopolymer and molecular brushes based on five novel diblock macromonomers (methoxy [oligo(ethylene glycol) e - block -oligo(propylene glycol) p ] methacrylates, OEG e OPG p MA) with different lengths of oligo(ethylene glycol) (e) and oligo(propylene glycol) (p) moieties

The synthesis of polymer molecular brushes based on novel diblock macromonomers (methoxy [oligo(ethylene glycol) e - block -oligo(propylene glycol) p ] methacrylates, OEG e OPG p MA) with different lengths of oligo(ethylene glycol) (e) and oligo(propylene glycol) (p) moieties has been studied. The solubility of polymers in organic solvents and water was investigated.

OEGeOPGpMA with the following average lengths of oligo(ethylene glycol) (e) and oligo(propylene glycol) (p) fragments: e = 7.0, p = 2.8 (E7P3), e = 7.0, p = 5.4 (E7P5), e = 7.0, p = 10.3 (E7P10), e = 10.3, p = 2.1 (E10P2), e = 10.3, p = 4.7 (E10P5), e = 0, p = 4.2 (E0P4).

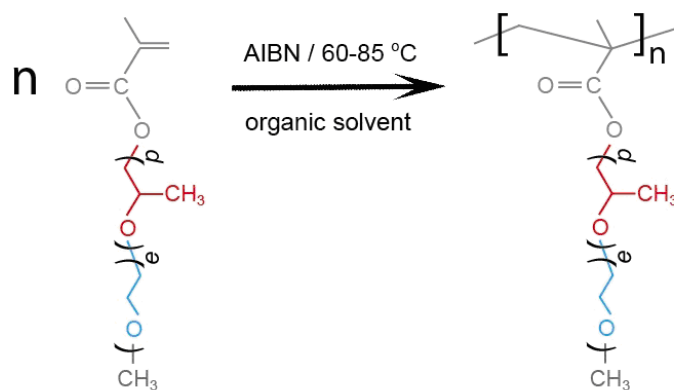


Figure 1. Scheme of synthesis.

All investigated polymers in chloroform, water, acetonytryle, TGF are dissolved differently. Sizes Under compare molecular and hydrodynamic characteristics was established that conformation of copolymers was close to coil in good solvent in TGF and acetonytryle. In other solvents was observed formation of micelle. Thermo-responsive properties have been demonstrated for OEG e OPG p MA polymers in aqueous solutions. The polymers have a critical solution temperature in the range from 34 to 71°C depending on the length of oligo(oxyalkylene) blocks of OEG e OPG p MA and polymer concentration. Thermo-responsive properties have been demonstrated for OEG e OPG p MA polymers in aqueous solutions. Phase separation temperatures of polymer brushes depend on concentration and composition.

Acknowledgements. This work was supported by the Russian Science Foundation (project No 20-13-00161).

# POLYURETHANE GEL-POLYMER ELECTROLYTES FOR LITHIUM POWER SOURCES

*Nizamov A.A.<sup>1</sup>, Yudina A.V.<sup>2</sup>, Baymuratova G.R.<sup>2</sup>, Yarmolenko O.V.<sup>2</sup>, Sazonov O.O.<sup>1</sup>, Davletbaeva I.M.<sup>1</sup>*

<sup>1</sup>Kazan National Research Technological University, Kazan, Russia

<sup>2</sup>Institute of Problems of Chemical Physics of RAS, Moscow Region, Russia

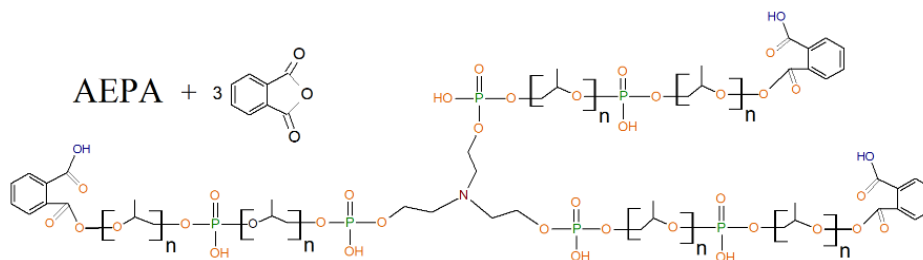
Postgraduate student, profile «Technology and processing of polymers and composites»

[nizamov564@mail.ru](mailto:nizamov564@mail.ru)

Currently, lithium-ion batteries (LIBs) are widely used in electronic devices such as mobile phones, laptops, and digital cameras due to their useful complex of characteristics, including low weight, high energy density, minimal memory effect, fast charging, low self-discharge, environmental friendliness [1]. The main component of the power source, which determines the energy consumption of the system, is the electrolyte. In LIBs, liquid electrolytes are used, which are solutions of lithium salts in aprotic organic solvents, the ionic conductivity of which at room temperature can reach values of  $10^{-3}$ - $10^{-2}$  S  $\text{cm}^{-1}$ .

One of the directions of LIB improvement is the replacement of the liquid electrolyte with a gel polymer electrolyte (GPE). Such the replacement increases LIB's safety and service life. GPEs consist a polymer matrix impregnated with a liquid electrolyte. Therefore, the important task is to create GPEs demonstrating high ionic conductivity at ambient temperature.

In this work, polyurethanes (PU) based on orthophosphoric acid aminoesters (AEPA) modified phthalic anhydride (PA) (Fig.) as a polymer matrix for GPE were synthesized and investigated. It was found that the introduction of the aromatic carboxyl-containing fragment into the branched structure of AEPA investigated in work [2] leads to increasing the ionic conductivity of AEPA-PA-PU compared with AEPA-PU by more than 3 times. High values of conductivity ( $\sim 2 \cdot 10^{-3}$  S  $\text{cm}^{-3}$ ) are observed in the region of relatively low phthalic anhydride content.



**Figure.** Scheme of interaction of AEPA with PA.

It was found that the nature of the dynamic viscosity, density, and surface tension dependences of AEPA-PA on the PA content is not additive and has two different areas of manifestation and is due to the formation of a specific supramolecular structure of AEPA-PA based on the combination of phosphate ions into clusters. The introduction of carboxylate anions into such clusters leads to corresponding changes in the size and packing of the corresponding macromolecular formations. At low PA content in AEPA-PA-PU, the formation of macromolecular centers packing occurs, which, as a result of the cooperative effect, leads to significant changes in the processes of supramolecular organization of these polymers. The peculiarities of the supramolecular structure of AEPA-PA-PU are the reason for an increase in the volume of cation-conducting channels and the mobility of  $\text{Li}^+$  ions in the polymer matrix.

## References

- [1] Li H., Xu Z., Yang J., Wang J. and Hirano S., *Sustainable Energy Fuels* **2020**, *4*, 5469-5487.
- [2] Davletbaeva I.M., Sazonov O.O., Fazlyev A.R., Davletbaev R.S., Efimov S.V. and Klochkov V.V. *RSC Adv.* **2019**, *9*, 18599-18608.

Acknowledgements. This work was supported by the Russian Science Foundation (project No 19-19-00136).

# THERMODYNAMICS OF SWELLING AND MECHANICAL CHARACTERISTICS OF HYDROGELS BASED ON POLYACRYLAMIDE COPOLYMERS WITH HYDROXYETHYL (METH)ACRYLATE

*Nokhrin K.A., Safronov A.P.*

Ural Federal University, Yekaterinburg, Russia  
Student  
[nohrin.kostia@mail.ru](mailto:nohrin.kostia@mail.ru)

Hydrogels based on polyacrylamide (PAM) are of great interest for practical use in various fields. As PAM is water soluble, non-toxic and low-cost, it is often used in medicine and bioengineering. PAM hydrogels are used in the production of contact lenses and in plastic surgery (for example, as a subcutaneous filler). They are often used as a matrix for growing cells and in the field of wound dressings. In addition, these hydrogels are widely used in many industrial areas.

However, the main shortcomings of PAM hydrogels are their rather weak mechanical strength, such as fragility, and moderate biocompatibility. To compensate these disadvantages, hydrogels based on various PAM copolymers are preferred rather than PAM itself. It is assumed that the use of hydrogels, which include PAM and a polymer with better biocompatibility, will provide better mechanical and biological properties. Therefore, it will expand the field of application of these hydrogels. In particular, hydroxyethyl methacrylate (HEMA) and hydroxyethyl acrylate (HEA) are often used as comonomers to obtain hydrogels in combination with PAM.

The objective of this work was to study thermodynamic parameters of swelling and hydration of hydrogels co-P(AAm/HEMA) and co-P(AAm/HEA) in dependence on the monomer ratio and to characterize the mechanical properties of hydrogels based on these copolymers.

Hydrogels were prepared by radical polymerization in water solution. Acrylamide (AAm) and 2-hydroxyethyl methacrylate (HEMA) in the first variant, and with 2-hydroxyethyl acrylate (HEA) in the second variant were used as the monomer mixture. Monomer mixtures were obtained with different mass ratios of components. The concentration of the monomer mixture was 1.6 M. Methylene diacrylamide (MDAA) was used as a crosslinking agent. The molar ratio of the crosslinking agent to the monomer mixture was 1: 100. The initiator of the polymerization reaction was ammonium persulfate (PSA). The synthesis was carried out at room temperature using an N, N, N', N'-tetramethyl-1,2-ethylenediamine (TEMED) catalyst. After the end of the synthesis, the hydrogels were washed with an excess of distilled water for two weeks, the water was changed every two days. Then, the equilibrium degree of swelling of the obtained hydrogels was determined.

The enthalpy of swelling of co-P(AAm/HEA) and co-P(AAm/HEMA) hydrogels were measured at using Calvet microcalorimeter. The dried samples were placed in glass ampoules, which were thermally equilibrated in the excess of water in calorimetric cell. After the equilibration the ampoule was broken and the heat effect of swelling was measured.

To study the mechanical characteristics, the Young's modulus of hydrogels was determined by the method of step-by-step uniaxial loading. For this, a cylinder with an easily moving piston was used so that the resistance of the piston could be neglected. A cylindrical gel sample was placed in the cylinder, the bases of which were normal to the height, so that the stress was the same throughout the entire length of the sample. Water was poured into the installation to maintain an equilibrium degree of swelling of the hydrogel. After that, the samples were subjected to loading and the photographs of the samples during compression were obtained using a digital microscope. The images were processed using the microscope software and the relative deformation of the hydrogels was calculated.

It was found that the swelling of individual polymers: PAM, PHEMA, and PHEA and copolymers is strongly exothermic. The negative values of the enthalpy of swelling increase in a row PHEA – PHEMA – PAM. Meanwhile, the large negative values of the enthalpy of swelling were mostly governed by the non-equilibrium contribution of the relaxation of the glassy structure of dry polymers during their plasticization by water.

It was found that the Young's modulus of hydrogels based on co-P(AAm/HEMA) significantly exceeds the Young's modulus of hydrogels based on individual polymers. The maximum increase in the Young's modulus of hydrogels for this system reached 300% compared to individual PAM hydrogel.

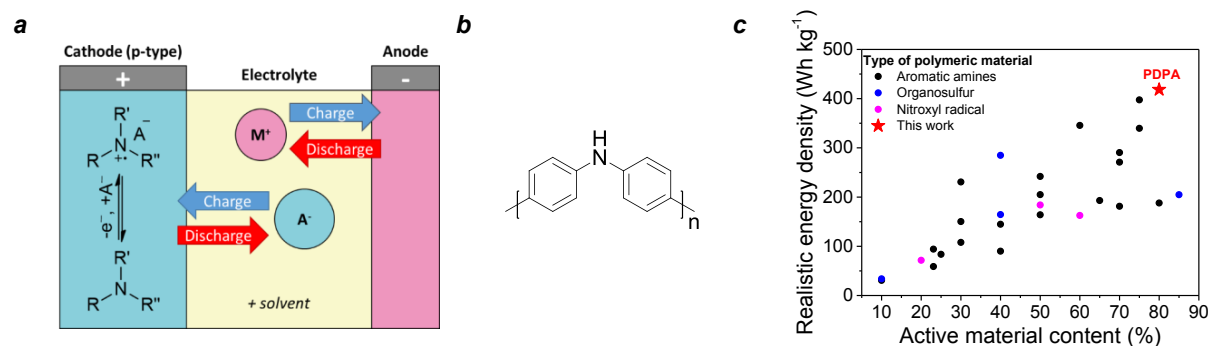
At the same time, in hydrogels based on co-P(AAm/HEA), the Young's modulus approached the values of an individual hydrogel based on PHEA. However, with the introduction of even a small amount of PHEA (10 wt. %) into the PAM hydrogel, the Young's modulus of the hydrogel increases by 230%.

Acknowledgements. This work was supported by the Russian Science Foundation (project No 20-12-00031)

The development of novel energy storage technologies constantly faces new challenges related to the rapidly growing demand for portable electronics and electric vehicles together with the increasing role of renewable energy sources. Additionally, in the recent years, there is an obvious trend for transition from traditional energy systems to sustainable smart grid ecosystems, which requires the widespread installation of stationary energy storage devices. To make it possible, there is an urgent need for development of cheap, cold-resistant and high-power batteries which are able to operate showing a good capacity retention in charge-discharge cycles and long-term storage, which is predominantly associated with the design of advanced electrode materials.

Dual-ion batteries (DIB) might be considered among the most promising post-lithium technologies for such applications due to the optimal combination of cost, environmental friendliness and performance metrics of the contained materials. This is a special type of energy storage devices, in which both ions of electrolyte salt (cations and anions) are involved in the redox processes. Due to the availability of electrode materials, dual-carbon batteries (DCB), where both electrodes are carbon-based materials received the most recognition. [1] However, DCB possess significant drawbacks such as low specific capacity from the cathode side (typically  $<110 \text{ mAh g}^{-1}$ ), [2] and high operation voltages ( $>5 \text{ V}$ ) [1,2] which results in electrolyte degradation.

As a reasonable alternative for carbon-based electrodes, a variety of organic cathode materials were recently reported in the related literature. [3]



**Figure 1.** Operational mechanism of amine-based dual-ion batteries (a), structural formula (b) and comparison with literature data (c) of cathode material PDPA.

In the present work, the synthesis and comprehensive electrochemical study of a large group of polymeric aromatic amines as active cathode materials for dual-ion batteries with high theoretical specific capacities ( $>160 \text{ mAh g}^{-1}$ ) were performed. Among the most significant results, we report the cathode materials for ultrafast lithium-based and high-energy potassium-based dual-ion batteries. In particular, the polyamine-based organic cathode PDPPD with impressive rate capabilities delivering specific capacities of up to  $84 \text{ mAh g}^{-1}$  at  $100\text{C}$  current rate in lithium batteries was developed. [4] The potassium-based dual-ion batteries were assembled and demonstrated the cathode energy densities of up to  $593 \text{ Wh kg}^{-1}$ , while previously reported for lithium batteries p-DPPZ was applied as an active electrode material. [5] Other studied phenazine-based polymers (PDPAPZ and PPTZPZ) also demonstrated a decent electrochemical performance. [6] Another significant step towards the dual-ion batteries with improved performance was made by increasing of active material content to impressive for organic cathodes 80%, while poly(diphenylamine) (PDPA) and multi-walled carbon nanotubes were applied as an active material and carbon filler, respectively. [7]

#### References

- [1] T. Placke, A. Heckmann, R. Schmich, P. Meister, K. Beltrp, M. Winter, *Joule* **2018**, 2, 2528
- [2] M. Wang, Y. Tang, *Adv. Energy Mater.* **2018**, 8, 1703320.
- [3] B. Esser, F. Dolhem, M. Becuwe, P. Poizot, A. Vlad, D. Brandell, *J. Power Sources* **2021**, 482, 228814
- [4] F. Obrezkov, A. Shestakov, V. Traven, K. Stevenson, P. Troshin, *J. Mater. Chem. A* **2019**, 7, 11430
- [5] F. Obrezkov, V. Ramezankhani, I. Zhidkov, V. Traven, E. Kurmaev, K. Stevenson, P. Troshin, *J. Phys. Chem. Lett.* **2019**, 10, 5440
- [6] F. A. Obrezkov, A. I. Somova, E. S. Fedina, S. G. Vasil'ev, K. J. Stevenson, P. A. Troshin, *Energy Technol.* **2021**, 9, 2000772.
- [7] F. A. Obrezkov, A. F. Shestakov, S. G. Vasil'ev, K. Stevenson, P. Troshin, *J. Mater. Chem. A* **2021**, 9, 2864.

**Acknowledgements.** This work was supported by the Russian Science Foundation (project no. 16-13-00111) and Russian Foundation for Basic Research (project no. 19-33-90233)



# PVA-BASED COATINGS WITH NOVEL COMPLEX BIOCIDAL ADDITIVES

*Ochenkov D.E.<sup>1,2</sup>, Mendeleev D.I.<sup>2</sup>, Kurenkov V.V.<sup>2</sup>*

<sup>1</sup> Mendeleev University of Chemical Technology, Moscow, Russia  
Student

<sup>2</sup> A.V. Topchiev Institute of Petrochemical Synthesis, Moscow, Russia  
[dmitrijocenkov@gmail.com](mailto:dmitrijocenkov@gmail.com)

**Introduction.** The development of new biocidal additives for polymeric materials is important for solving two problems: protecting polymers from biodegradation and limiting the contact transmission of pathogens. By now, a large number of different biocidal additives for various applications have been created, but a common disadvantage of most of them is their high toxicity. Devoid of this drawback are the non-toxic high molecular weight guanidine compounds, the biocidal activity of which against a wide range of microorganisms and micromycetes has been proven. The introduction of such additives directly into polymers is ineffective due to the leaching of polyguanidines from the polymer matrix and their poor dispersibility in most polymers; therefore, it has been proposed to use complex biocidal additives (CBA) – guanidine polymers immobilized on montmorillonite. The composition of CBA and their method of introduction into polymers must be adjusted depending on the properties of the polymer matrices.

The biocidal efficacy of CBA in polymer composites has been confirmed [1]. Due to the high polarity of CBA, their use is promising for water-dispersion materials and paints. A potential problem is the possibility of destabilizing the dispersion in the presence of a polyelectrolyte (guanidine polymer).

This work is devoted to the development of a method of introduction of CBA into water-dispersion paints based on aqueous dispersion of polyvinyl acetate (PVA), brand 51/10S.

**Methods.** CBA was obtained by the adsorption of biocidal polymers (polyhexamethylene guanidine hydrochloride and polyhexamethylene guanidine phosphate) on montmorillonite from an aqueous solution [1]. Dispersions without pigments as well as water-dispersion paints based on the standard paint formulation WD-VA 251, modified by addition of CBAs, were studied. The rheological properties of dispersions were measured using a Lamy Rheology RM-200 rotary viscometer. The properties of the obtained paints and coatings were characterized by conventional methods of paint and varnish industry, including ISO 2431, ISO 1524, ISO 2814, ISO 1522.

**Results.** By the standard method of adsorption from an aqueous solution [1] CBAs containing 20 and 30 wt % guanidine polymers, with guanidine polymers adsorbed partially by the ion exchange mechanism, were obtained. The adsorption mechanism and composition of CBA were confirmed by thermogravimetry and elemental X-ray fluorescence analysis. The compatibility of montmorillonite (inorganic base of CBA) with PVA has been confirmed by X-ray structural analysis.

The stability of the PVA aqueous dispersion in the presence of CBA, as well as of natural montmorillonite and free guanidine polymer, was determined by precipitation with dilution according to the method [2]. It was found that dispersions containing CBA in an amount up to 2,8 % wt. are not inferior in stability to the initial dispersion (in contrast to dispersions with a free guanidine polymer). Rheological measurements showed that the introduction of CBA (in contrast to natural montmorillonite [2]) does not cause a significant change in the rheological properties of the dispersion (the flow curves of dispersions with CBA and without CBA are close), which makes it possible to regulate the content of the biocidal additive over a wide range for ensuring the required biocidal properties of the coating.

Comparative tests showed that to ensure better dispersion of CBA in an aqueous dispersion material, it is advisable to use CBA with a reduced content of guanidine polymer – 20 % wt., since CBA with 30 % wt. of guanidine polymer forms large stable aggregates in an aqueous dispersion.

Tests of coatings have shown that the use of free guanidine polymers in the composition is inadvisable due to a sharp deterioration in the water resistance of the coatings. Coatings with CBA match the pristine coating in terms of water resistance. The pendulum hardness of coatings containing CBA, while slightly lower than the hardness of coatings without CBA (0,30 versus 0,35 by ISO 1522), is within the acceptable values for these materials.

**Conclusions.** The introduction of biocidal additives based on guanidine polymers into water-dispersion materials has been developed (on an example of PVA dispersion). The obtained materials are not inferior to the base materials in terms of sedimentation resistance and rheological properties, the characteristics of the coatings are satisfactory. The results obtained confirm the prospects for the development of new complex additives for use as part of water-dispersion materials for various purposes.

## References

- [ 1] Rus. J. of Appl. Chem. **2018** , 91, 1297–1304
- [2] Colloid J. **2017** , 79, 588-595

Acknowledgments . This work was carried out within the State Program of TIPS RAS

# NOVEL POLYETHERIMIDES BASED ON DIETHYLTOLUYLENEDIAMINE: SYNTHESIS, PHYSICOCHEMICAL AND GAS TRANSPORT PROPERTIES

*Orlova A.M.<sup>1</sup>, Tsegelskaya A.Yu.<sup>1</sup>, Alentiev A.Yu.<sup>2</sup>, Kuznetsov A.A.<sup>1</sup>*

<sup>1</sup>Enikolopov Institute of Synthetic Polymer Materials, Russian Academy of Sciences, Moscow, 117393 Russia

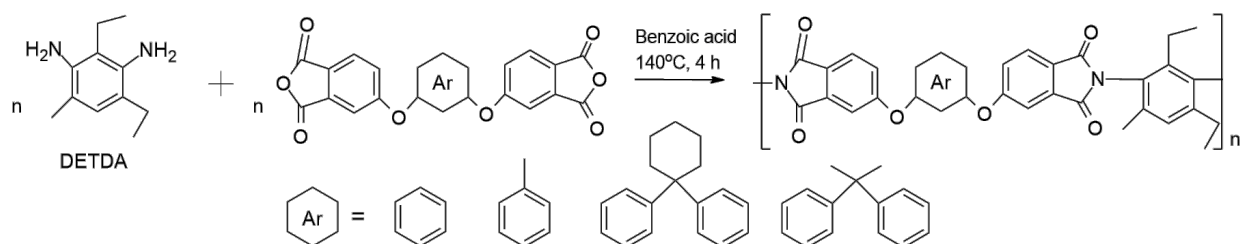
<sup>2</sup>Topchiev Institute of Petrochemical Synthesis, Russian Academy of Sciences, Moscow, 119991 Russia

Junior Researcher

[orlova\\_am@ispm.ru](mailto:orlova_am@ispm.ru)

Aromatic polyimides (PI) are an important class of polymers that are used as gas separation membranes due to their high selectivity of gas and vapor separation [1]. High selectivity results from the intrinsic behavior of imide structure and the presence of rigid aromatic moieties. However, these same factors contribute to the low permeability. Therefore, there is such an unsolved problem for membranes based on PIs as overcoming the compromise ratio between gas permeability and selectivity. One of the methods for obtaining highly permeable PIs is the use of "hard" monomers, as well as monomers with bulky substituents, the introduction of which leads to a decrease in the chain packing density and an increase in free volume due to the weakening of interchain interactions [2]. On the other hand, many works are devoted to synthesizing such PIs, which combine both the introduction of flexible bonds and bulky side substituents to achieve a balance between high permeability while maintaining good selectivity [3]. However, the low reactivity of hindered monomers can create difficulties in the preparation of high molecular weight PI by standard synthesis methods.

In this work, we synthesized a series of polyetherimides (PEI) of a new structure based on hindered diethyltoluylene diamine (DETDA) with the participation of various aromatic tetracarboxylic acid dianhydrides by one-step method of high-temperature polycondensation in benzoic acid melt (Fig.1). This method is weakly sensitive to the reaction ability of monomers [4]. The structure of the obtained PEIs was confirmed by IR- and <sup>1</sup>H NMR- spectroscopy. The synthesized polymers are soluble in a wide range of organic solvents and form strong films with a tensile strength at break up to 68 MPa and elongation at break up to 89%. PEIs demonstrate resistance to thermal-oxidative degradation up to 400°C, and have high glass transition temperatures (up to 292°C). According to the results of the study of the gas transport properties of the PEI series, it was found that a change in the bisphenol fragment in the PEI series with double-hinged fragments does not make a significant contribution to the change in the gas separation characteristics.



**Figure 1.** Scheme of polycondensation of PEI by a one-step method in benzoic acid.

## References

- [1] Ohya H., Kudryavsev V.V., Semenova S.I. Polyimide membranes: applications, fabrications and properties. CRC Press, 1997.
- [2] Kuznetsov A.A. et al. Membranes and Membrane Technologies. 2019, 1 (5), 316-322
- [3] Belov N. et al. Separation and Purification Technology. 2019, 217, 183-194
- [4] Kuznetsov A.A. High Perform Polym. 2000, 12 (3), 445-460

Acknowledgements. This work was supported by Russian Foundation for Basic Research (project No 19-03-00820).

## NOVEL PH-SENSITIVE POLYPEPTIDE NANOPARTICLES AS DRUG CARRIERS

Osipova O.M.<sup>1</sup>, Korzhihova-Vlakh E.G.<sup>1,2</sup>, Tennikova T.B.<sup>1</sup>

<sup>1</sup>Saint Petersburg State University, Saint Petersburg, Russia

<sup>2</sup>Institute of Macromolecular Compounds of Russian Academy of Sciences, Saint Petersburg, Russia

PhD student

olya\_osipova\_06\_01@mail.ru

Controlled drug delivery technology represents one of the most rapidly advancing areas of science. Synthetic drug delivery systems have attracted great interest as they are simple to prepare, rather stable and easy to modify compared to viral vectors. Unfortunately, their application has been severely limited due to the low transfection efficiency. Efforts to improve the effectiveness of nonviral delivery systems have been focused on developing of novel drug carriers by chemical synthesis and modifications. [1-2]

Cationic drug carriers are perspective in this regard since they can condense negatively charged molecules (DNA, RNA, etc.) into compact forms that are resistant to serum proteins. Moreover, positive surface charge can facilitate the cellular penetration due to interactions with negatively charged cell surface. Finally, the endosomal escape can be significantly facilitated due to the "proton-sponge effect". [1, 3]

This work is devoted to the creation of biocompatible polypeptide nanoparticles. The target copolymers were synthesized via ring-opening polymerization of N-carboxyanhydrides of  $\alpha$ -amino acid derivatives. The resulting copolymers contained positively charged and hydrophobic amino acids that allowed effective cell penetration, as well as histidine which provided pH sensitivity for the delivery system and rapid release from endosomes.

The obtained nanoparticles were characterized by nanoparticle tracking analysis and dynamic light scattering; their morphology was studied by transmission electron microscopy. Transfection and cell cytotoxicity of the particles were studied *in vitro* using several cell lines (ARPE, SIRC, and MDA-MB231). The nanoparticle stability, loading capacity and drug release were investigated. The experiment of intracellular siRNA delivery was successful.

### References

- [1] Benoit, D. et al. *Bioconjug Chem.* **2017**, 14(2):412-433.
- [2] Zhang, P. et al. *Top Curr Chem.*, **2017**, 375(2), 26-45.
- [3] George, A. et al. *Int. J. Pharm.*, **2019**, 244–264.

Acknowledgements. This work was supported by Russian Foundation for Basic Research (project No 20-33-90181.).

# INFLUENCE OF SYNTHETIC POLYELECTROLYTES ON THE STRUCTURE OF LIPID MONOLAYER

*Panaeva M.A.<sup>1</sup>, Bykov A.G.<sup>1</sup>*

<sup>1</sup>Saint Petersburg State University, Saint Petersburg, Russia

Student

[st068796@student.spbu.ru](mailto:st068796@student.spbu.ru)

Pulmonary surfactant is complex mixture of lipids and proteins. Solution of pulmonary surfactant covers the inner surface of lungs and maintains low values of surface tension in course of compression and expansion. The lack of these surfactants causes the respiratory distress syndrome, which is a leading reason of premature infant's death. Natural pulmonary surfactants extracted from animal lungs are used to prevent the respiratory system collapse of newborn children. Recently it has been shown that natural pulmonary surfactants improves medical treatment of patients with severe disease of coronavirus infection COVID-19 [1].

Proteins provide accelerations of adsorption and formation of multilayer structure in surface layer of pulmonary surfactant solutions due to their own surface activity and ability to form complexes with lipids. However, the mechanism of their action is unknown so far. Therefore, many studies are devoted to investigation of surface properties of pulmonary surfactant solutions. In this work the dynamic surface properties for spread monolayers of lipids on solutions of different polyelectrolytes was investigated. The dynamic surface elasticity of lipid monolayer was measured in broad range of surface tension using new method, which gives a possibility to investigate dynamic surface properties under near physiological conditions [2]. It was shown, that characteristic time of relaxation processes at deformation of lipid monolayers strongly depends on both electrostatic and hydrophobic interactions between lipids and polyelectrolytes. Presence of hydrophobic side chains and charged group on polyelectrolyte improve formation of complexes, especially if macromolecule is oppositely charged to lipids. Probably, the formation of multilayer structure at the surface of solution is possible only at the optimum ratio of hydrophobic and electrostatic interactions between lipids and polyelectrolytes.

## References

- [1] Veldhuizen R.A.W., Zuo Y.Y., Petersen N. O., Lewis J.F., Possmayer F. Expert review of respiratory medicine **2021**, 15, 597–608  
[2] Ravera F., Miller R., Zuo Y.Y., Noskov B.A., Bykov A.G., Kovalchuk V.I., Loglio G., Javadi A., Liggieri L. Current Opinion in Colloid & Interface Science, **2021**, 101467

Acknowledgements. This work was supported by Russian Foundation for Basic Research (project No 20-33-70056).

# AN INFLUENCE OF THE CRYSTALLIZATION EFFECT ON FEATURES OF THE STRAIN BEHAVIOR OF POLYURETHANE ELASTOMERS BASED ON OLIGOESTERS

*Perepada M.V.*

Institute of Technical Chemistry of the Ural Branch of the Russian Academy of Sciences – a branch of the Perm Federal Research Center of the Ural Branch of the Russian Academy of Sciences, Perm.

Postgraduate student

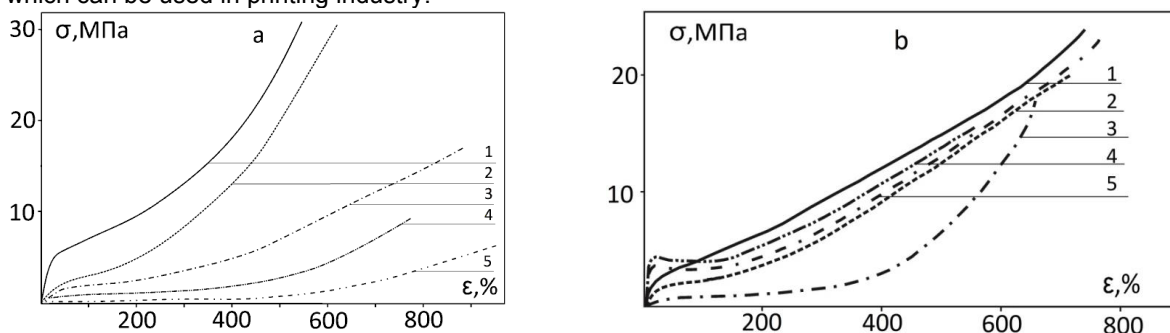
[Mari.perepada@mail.ru](mailto:Mari.perepada@mail.ru)

**Introduction:** Structural morphology largely determines the thermal, mechanical and electrical properties of polymers and, as a result, their practical application. Also, one of the problems in the manufacturing products made of polyurethane compounds is the possible crystallization after manufacture. It is known that as a result of uncontrolled crystallization of such compositions, the resulting products lose their elasticity and fail. Therefore, the study of the regularities of the crystallization of polyurethane compositions based on domestic oligoesters is an urgent task of the development of novel polymer materials science.

**Methods:** Initial components for the synthesis of polyurethane samples were 4,4-diphenylmethanediisocyanate (MDI) and oligoester P-6 (polyethylene glycol adipate,  $MN=1954 \text{ g}\cdot\text{mol}^{-1}$ ), as well as 1,4-butanediol (BD). The synthesis was carried out by a two-stage method with the preliminary production of pseudoprepolymers based on MDI and the mentioned oligoester (with the ratio of  $\text{NCO}/\text{OH}=3.8$  for the PDU series and  $\text{NCO}/\text{OH}=3$  for the PDE one). The mode of synthesis of prepolymers and elastomers corresponded to the work [2]. Curing was carried out with mixtures of polyester P-6 and butanediol in the following ratios (molar): 0/100 (for PDU-1 and PDE-1); 0.25/0.75 (for PDU-2 and PDE-2); 50/50 (for PDU-3 and PDE-3); 0.25/0.75 (for PDU-4 and PDE-4); 0/100 (for PDU-5, PDE-5). Mechanical tests of samples of the obtained materials were carried out according to Russian standards GOST 260-75, GOST 263-75.

**Results:** As can be seen from the data obtained (Fig. 1a), a consistent increase in the content of low-molecular-weight BD in the curing mixture in the series leads to an increase in the modulus due to the formation of domain of hard segments forming during the reaction of BD with isocyanate groups. These domains can play a role of reinforcing filler for elastomers.

A more complex picture can be observed for the PDE series (Fig. 1b) where the crystallization effect is clear for the PDE-4 and PDE-5 samples containing the prevailing amount of P-6 polyester in the curing mixture. The stress versus strain plots for them has the form characteristic for the strain of polymer samples with the effect of forced rubberlike elasticity. As the content of butanediol in the curing system increases, the crystallization effect disappears and the remaining samples of the PDE series show behavior similar to the samples of the PDU series, which is explained by the manifestation of difficulties for crystallization introduced into the system by hard domains. For these samples, the tensile strength also reaches a value of 18–25 MPa, which indicates the possibility of using the effect of partial crystallization to enforce the elastomers. The most interesting for practical application was the composition of PDE-3 with a Shore A hardness index of 63 units, which can be used in printing industry.



**Figure 1.** The dependence stress versus strain for samples of the PDU(a) series and PDE(b) one, where the curves 1,2,3,4,5 correspond to the compositions of PDU-1÷5 and PDE-1÷5, respectively

**Conclusions:** Generally, crystallization cannot be considered an unambiguously negative factor in polymer materials science, since it can, within a certain framework, be used as an effective method for regulating the functional properties of polymers. This study allowed us to evaluate the possibility of using one of the domestic oligoesters for the development of injection molding compositions with a hardness level of 60–70 Shore A units.[3]

## References

- [1] Bakirova I.N., Galkina N.V. Journal of Applied Chemistry, **2017**, 90, 1258–1261.
- [2] Tereshatov V.V., Slobodinyuk A.I., Makarova M.A., Pinchuk A.V., Senichev V.Yu. Russian Journal of Applied Chemistry, **2016**, 89, 943–948.
- [3] Sonnenschein M. F., Lysenko Z., Brune D.A., Wendt B.L, Schrock A.K. Polymer. **2005**, 46, 10158–10166.

**Acknowledgements.** The work was carried out using the equipment of the Central Research Center "Research of materials and Substances" of the PFIC of the Ural Branch of the Russian Academy of Sciences and budget funds, within the framework of the state task "ITH of the Ural Branch of the Russian Academy of Sciences" (State registration No. AAAA18-118022290056-8).

SYNTHESIS AND INVESTIGATION OF PROPERTIES OF TRANSPARENT (CO)POLYMERS BASED ON ACYCLIC AND ALICYCLIC DIAMINES AND DIANHYDRIDES OF AROMATIC TETRACARBOXYLIC ACIDS

*Pichugin A.M., Nakhod M.A., Dubinina A.D.*

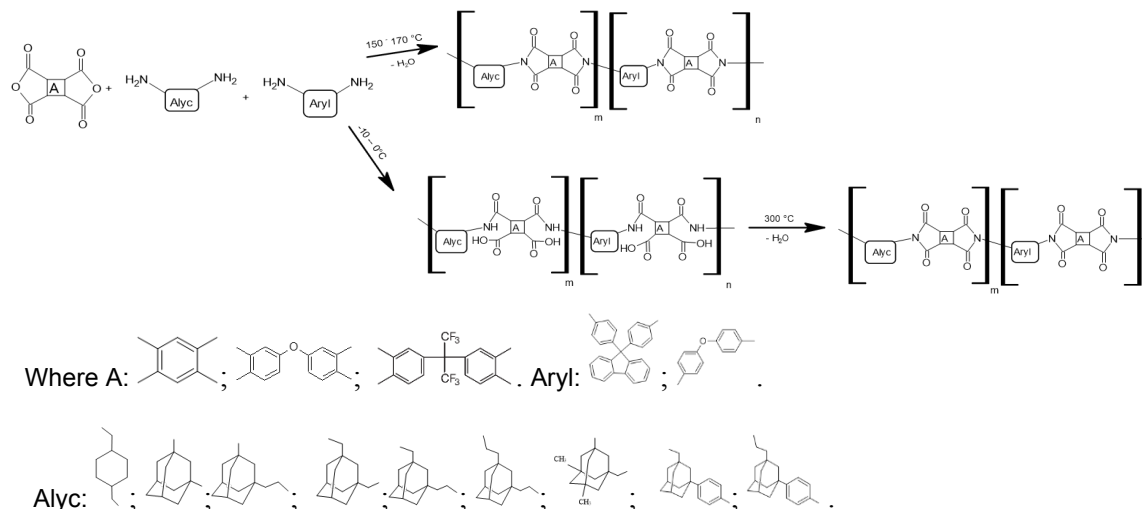
Volgograd State Technical University, Volgograd, Russia

PhD student

[alexandr.5420@yandex.ru](mailto:alexandr.5420@yandex.ru)

It is known that aromatic polyimides have a number of high performance characteristics and are widely used in the production of flexible optoelectric devices and microelectronics [1] as well as as a substrate for various biosensors [2,3].

We synthesized polyimide films based on adamantane-containing diamines and aromatic dianhydrides, showing high optical and dielectric properties.



**Figure 1.** Scheme of one-stage and two-stage synthesis of polyimides

It was found that the obtained polyimides have values of the permittivity from 2,4 to 2,7 and optical transparency  $T_{400}$  from 59 to 85 %, which correlates with quantum chemical calculations of the energy  $\Delta\varepsilon$  of the electron transition from the highest occupied molecular orbital (HOMO) to the lowest unoccupied molecular orbital (LUMO). Also, the obtained polyimides had high thermal and hydrolytic stability, which indicates their perspective use in the production of microelectronics, biosensors, etc.

### References

- [1] Kim M., Park J. *Nanoscale* **2016**, 8, 9504–9510.  
 [2] Rousche P. J., Pellinen D. S. *IEEE Transactions on Biomedical Engineering* **2001**, 48, 361–370.  
 [3] Xu M., Obodo D. *Biosensors and Bioelectronics* **2019**, 124–125, 96–114.

Acknowledgements. This work was financially supported by the Russian Foundation for Basic Research (Project No. 19-33- 90119-19).

## DEGRADATION OF POLYMER BLENDS BASED ON POLYLACTIDE

*Podzorova M.V.<sup>1,2</sup>, Tertyshnaya Yu.V.<sup>1,2</sup>, Morokov E.S.<sup>1</sup>*

<sup>1</sup> Emanuel Institute of Biochemical Physics Russian Academy of Sciences, Moscow, Russia

<sup>2</sup> Plekhanov Russian University of Economics, Moscow, Russia

Researcher

[mariapdz@mail.ru](mailto:mariapdz@mail.ru)

Bioresorbable poly(L-lactide) (PLA) and their modifications is one of the most intensively studied polymers in recent years. The main question is degradation process of PLA specimens. It is known that the degradation of PLA associated with the hydrolysis of ester bonds of polymer chains, which chemical reaction kinetics depends on many factors [1]. The hydrolysis rate results from environmental conditions and catalysts (including biological), as well as by chemical and enantiomeric composition of the polymers [2]. The molecular weight of PLA significantly affects the kinetics of its degradation, especially at the initial stages of hydrolysis.

Moreover, the reaction of photodegradation of PLA and their composites has a similar mechanism to hydrolysis. In work [3], the influence of ultraviolet radiation with a wavelength of 254 nm on the properties of PLA was described. The decrease in molecular weight and destruction of polylactide was shown after 16 hours of the experiment. Chain splitting processes cause morphological and mechanical changes.

Degradation of PLA during heat treatment is mainly caused by intramolecular transesterification reactions that result in the formation of cyclic oligomers of lactic acid and lactide. At the same time, the recombination of cyclic oligomers with linear polyesters occurs (insertion reactions); however, molecules with longer chains are preferred.

In works [4, 5] it was revealed that the microorganisms less affected PLA bioresorption than, poly(3-hydroxybutyrate) and polycaprolactone.

Here, we studied the degradation process of blends of polylactide and low-density polyethylene (LDPE) including an analog of recycled polyethylene under exposure to various aggressive environmental factors. It was found that, the blends have sorption capacity of 2-6% higher in comparison with pure PLA and LDPE. The PLA crystallinity increased due to the destruction of its amorphous phase during hydrolysis. The blends with LDPE concentration of 40 and 50 wt. % have highest rate of absorption. The value of water absorption in these polymers was about 10%. Thus, the dependence of an increase of water absorption with the growth of the concentration of aged polyethylene was found.

The strength characteristics of PLA significantly decreased after the UV irradiation during 25 h, and brittle failure of the polymer was observed after time irradiation of 50 h. Both pure LDPE and the specimens with LDPE concentration above 50 wt % have shown UV resistance under the given conditions.

It was also shown that the introduction of thermally aged LDPE as an analog of secondary raw materials affects the microstructure and properties of PLA compositions. The physicomechanical characteristics of polymer blends decreased at the LDPE concentration above 30 wt. %. The addition of this fraction influenced the rate of destruction of the polymer materials under the experiment.

### References

- [1] Trofimchuk E.S., Moskvina M.A., Nikonorova N.I., Efimov A.V., Garina E.S., Grokhovskaya T.E., Ivanova O.A., Bakirov A.V., Sedush N.G., Chvalun S.N. *European Polymer Journal*, **2020**, *139*, 110000
- [2] Podzorova M.V., Tertyshnaya Yu.V., Popov A.A. *AIP Conference Proceedings*, **2020**, *2310*, 020258
- [3] Olewnik-Kruszkowska E., Koter I., Skopinska-Wisniewskab J., Richert J. *Journal of Photochemistry and Photobiology A: Chemistry*, **2015**, *311*, 144-153
- [4] Pranamuda H., Tokiwa Y., Tanaka H. *Applied and Environmental Microbiology*, **1997**, *63*, 1637-1640
- [5] Tokiwa Y., Calabia B.P. *Journal of Polymers and the Environment*, **2007**, *15*, 259-267

Acknowledgements. This work was supported by the Russian Science Foundation (project No 21-72-10038).

## 3D-PRINTING OF HYDROGEL/TRICALCIUM PHOSPHATE COMPOSITE

*Preobrazhenskiy I.I., Putlyaev V.I.*

Moscow State University, Moscow, Russia  
PhD Student  
[preo.ilya@yandex.ru](mailto:preo.ilya@yandex.ru)

Currently, there is a growing interest in additive technologies, which are a universal technological platform for computer-aided design and rapid production of materials. In the case of biomaterials, 3D printing provides osteoconductive properties (i.e. associated macropores) and a personalized approach to patient treatment. Hydrogels based on polyethylene glycol (PEG) derivatives can be obtained by the photopolymerization reaction, which is the basis of the stereolithographic 3D printing method [1]. Hydrogels are unique materials for medicine, due to their characteristics, such as swelling and diffusion properties [2]. Hydrogels have a highly swollen three-dimensional structure similar to soft tissues and allow diffusion of nutrients and cellular waste through the elastic network. To create new biomaterials, calcium phosphates are widely used, due to their excellent biological properties [3]. It is possible to create composites based on hydrogels filled with calcium phosphates, which will increase their bioactivity and provide opportunity to control composites properties, such as swelling, degradation rate and strength. This work was aimed at obtaining of hydrogel-based composites, filled with calcium phosphate, with complex architecture through DLP 3D-printing for creating material, which can be used in bone tissue regeneration.

In this work monomers of polyethylene glycol derivatives, such as PEG-methacrylate or PEGMA ( $M_w=350$  Da) and PEG-diacrylate or PEGDA ( $M_w=575$  Da), were chosen, due to its good biological properties, ability to degrade in body environment, commercial availability, and applicable for DLP printing. These monomers are liquids at room temperature and have a good solubility in water. Pre-synthesized calcium phosphate (tricalcium phosphate ( $Ca_3(PO_4)_2$ , TCP), brushite or dicalcium phosphate dihydrate ( $CaHPO_4 \cdot 2H_2O$ , DCD), octacalcium phosphate ( $Ca_8(HPO_4)_2(PO_4)_4 \cdot 5H_2O$ , OCP)) were used for filling hydrogel. Hydrogels and filled composites were obtained by photopolymerization reaction with photoinitiator Irgacure®819. Mixing of all components was performed on a magnetic stirrer for 10 minutes, after which photopolymerization was performed under a household UV lamp and samples with the gyroid structure were obtained at DLP 3D-printer Ember (Autodesk, USA).

It was found that the usage of  $\alpha$ -TCP ceramic powder as a filler for hydrogels allowed to increase the filler fraction from 10 up to 60 wt.% in comparison with OCP and DCD without significant thickening of photosuspension for DLP printing. The possibility of TCP conversion into OCP or DCD by soaking of the composite in buffer solutions was tested. Also, the possibility to tune hydrogel properties (such as swelling, degradation rate, photopolymerization time) by using mixture of monomers and filling hydrogels was shown. It was found that the increase of methacrylate content allows obtaining composites with a higher swelling and faster biodegradation behavior, but with long photopolymerization time. Finally, the main parameters of DLP printing for biocomposites based on PEGMA/PEGDA hydrogels were found, and the macroporous biocomposite filled with 60 wt.%  $\alpha$ -TCP with gyroid structure was obtained. It was shown that the change in the radiation time of a single layer during 3D printing makes it possible to vary the porosity of the obtained biomaterials. The combination of composites unique properties makes them perspective for further biomedical evaluation as elastic bioimplants for bone tissue recovery.

### References

- [1] Preobrazhenskiy I. I., Tikhonov A. A., Evdokimov P. V., Shibaev A. V., Putlyaev V. I. *Open Ceramics* **2021**, 100115.
- [2] Преображенский И.И., Тихонов А.А., Климашина Е.С., Евдокимов П.В., Путляев В.И. *Известия АН. Серия химическая* **2020**, 8, 1601-1603.
- [3] Radwan N. H., Nasr M., Ishak R. A., Abdeltawab N. F., Awad G. A. *Carbohydrate Polymers* **2020**, 244, 116482.

This work was supported by the Russian Science Foundation (project № 19-19-00587).



# RHEOLOGICAL PROPERTIES OF COMPOSITES BASED ON POLYISOPRENE AND POLYMETHYLSILSESQUIOXANE

*Rakhmanova P.A.*<sup>1</sup>, *Mironova M.V.*<sup>2</sup>

<sup>1</sup>D.I.Mendeleev University of Chemical Technology of Russia, Moscow, Russia

<sup>2</sup>A.V.Topchiev Institute of Petrochemical Synthesis, RAS, Moscow, Russia

Student

PamPolina99@yandex.ru

Elastomer-based composites are widely used in many industries. Carbon black and silica have remained traditional rubber fillers, which significantly improve their thermal and mechanical properties, for many decades [1]. However, the interest of researchers in the search for new, more environmentally friendly and technological modifying additives remains high. One of the promising areas of research in this area is the synthesis of organosilicon polymers with a hybrid organo-inorganic architecture, in particular oligo- and polysilsesquioxanes [2]. While retaining the reinforcing silica "core" of the SiO<sub>x</sub> composition, these compounds exhibit a fairly high compatibility with carbon chain rubbers due to the organic "periphery" of the -CH<sub>3</sub> composition [3].

One of the critical issues in the use of organosilicon fillers is the assessment of their effect on the rheological properties of rubber-based suspensions. It is the study of this issue that is the purpose of this work. The rheological properties of the filled compositions were studied using the example of model systems. Low molecular weight polyisoprene grade NMPI-500 (PI) was used as a polymer matrix, and polymethylsilsesquioxane (PMSS) of general formula [CH<sub>3</sub>SiO<sub>1.5</sub>]<sub>n</sub> was used as an organosilicon filler.

The work investigated compositions with a filler content of 5–35 wt.%. To obtain a composite, rubber was mixed with a filler on a three-roll laboratory mixer (EXAKT, Otto Herrmann, Germany). The study of the rheological parameters of the prepared mixtures was carried out on a rotary rheometer "MARS" ("Thermo Haake", Germany). A plane – plane measuring cell (diameter 20 mm) was used. The flow curves of the compositions were obtained with a stepwise change in the controlled shear rate in the range from 10<sup>-4</sup> to 10 s<sup>-1</sup> and with long-term measurements at a given constant shear rate. Dynamic tests were carried out at a constant deformation amplitude of 1% in the frequency range from 0.01 to 100 Hz. The morphology of the filled systems was studied using a laboratory optical microscope "Biomed 6 PO" (Biomed-service, Russia).

The rotational rheometry method was used to obtain the dependence of the viscosity on the shear stress and the frequency dependence of the dynamic modules. Particular attention was paid to the deformation curves of the compositions, obtained as a result of a long experiment, with an estimate of the viscosity under the conditions of the transient process (change in the shear rate from low to high). This characteristic reflects the strength of the initial structure of the filled system, and for systems with PMSS there is a noticeable change in the structure of the polymer mixture under the influence of deformation. Compositions with low filling, like the initial polyisoprene, exhibit newtonian behavior. In highly filled systems, starting from 25 wt.% at various applied stresses, a disproportionate change in the slope of the deformation development curves and, consequently, in the shear rate is observed. This indicates the manifestation of viscosity anomaly. This pattern manifests itself both in the area of moderate strain rates and significantly higher ones. Dynamic tests of composites showed that with an increase in the filler content from 5 to 20 wt.%, the modulus values gradually increase, but the nature of the frequency dependences remains unchanged, i.e. for all systems  $G' \sim \omega^{1.4}$  and  $G'' \sim \omega^{0.9}$ . As the concentration of the filler increases, the "crossover point" shifts to the left, i.e. the elastic component begins to exceed the viscous one at lower frequency values. The addition of 30 wt.% filler significantly affects not only the absolute values, but also the nature of the change in dynamic modules with frequency. For a highly filled system with 35 wt.% PMSS, already in the entire frequency range, the accumulation modulus  $G'$  exceeds the loss modulus  $G''$ .

## References

- [1] J.E. Mark, B. Erman, F.R. Eirich (Eds.). *Science and Technology of Rubber*, Academic Press, Elsevier, **2005**
- [2] Meshkov I.B., Kalinina A.A., Kazakova V.V., Demchenko A.I. *INEOS OPEN*, **2020**, 3 (4), 118–132
- [3] Migulin D., Tatarinova E., Meshkov I. Cherkhaev G., Vasilenko N., Buzin M., Muzafarov A. *Polymer International*, **2016**, 65 (1), 72-83

Acknowledgements. This work was supported by Russian Foundation for Basic Research (project No 17-79-30108).

# REMARKABLE IMPROVEMENTS OF TRANSPORT PROPERTIES OF POLYETHERIMIDE MEMBRANES USING PEROVSKITES

*Rostovtseva V.A.<sup>1</sup>, Polotskaya G.A.<sup>1,2</sup>, Pulyalina A. Yu.<sup>1</sup>*

<sup>1</sup>Saint Petersburg State University, Saint Petersburg, Russia

<sup>2</sup>Institute of Macromolecular Compounds RAS, Saint Petersburg, Russia

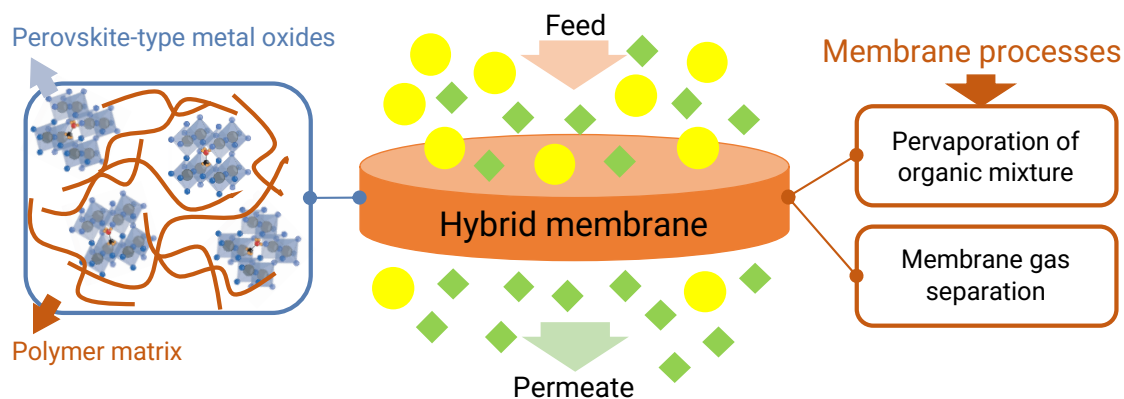
PhD Student

[v.rostovtseva@spbu.ru](mailto:v.rostovtseva@spbu.ru)

Polymers have attracted a lot of attention in the field of membrane separation processes because of their high stability and low cost. Taking into account the advantages of polymer membranes, the inclusion of inorganic nanoparticles in a polymer matrix can be a promising approach for the development of materials with improved operational and transport properties. Layered perovskites seem to be promising modifiers due to a combination of two factors: 1) the possibility of creating selective transport channels through the interlayer space of the perovskite structure; 2) the possibility of increasing the free volume in the membrane, which should increase the membrane permeability due to solid crystalline particles, which will contribute to loosening the packing of polymer chains.

This research aimed to examine the influence of perovskite addition on the structure, physicochemical and transport properties of the polyetherimide/perovskite composites. Special attention was paid to the study of the structure of hybrid membranes by SEM and element analysis, which revealed different compositions of the upper and lower surfaces of perovskite-containing membranes. The influence of inorganic modifiers on thermal properties, surface hydrophilicity and film density was estimated.

Transport behavior and separation properties were investigated during membrane processes of gas and liquid mixtures' separation. Among the processes of membrane separation, pervaporation is an effective method for separating liquid mixtures, especially in the case of near-boiling and azeotropic mixtures, since it allows to reduce the need for energy and additional components. Membrane gas separation method allows continuous, reagentless and harmless separation of gases or obtaining a mixture enriched with one component using available compact equipment. The inclusion of perovskites in the polyetherimide matrix provided membrane with high selectivity and increased permeability.



**Figure 1.** Scheme of hybrid membrane based on the polyetherimide/perovskite composites.

**Acknowledgements.** This work was supported by Russian Foundation for Basic Research (project No 19-33-90048) and grant of the President RF [project No MK-1280.2020.3]. Equipment of Resource Centers of St. Petersburg State University, namely, the Interdisciplinary Resource Center “Nanotechnologies”, “Thermogravimetric and calorimetric methods of investigation”, “Centre for X-ray Diffraction Studies”, “Cryogenic Department”, and the Education Resource Centre in the direction of chemistry were used for membrane investigations.

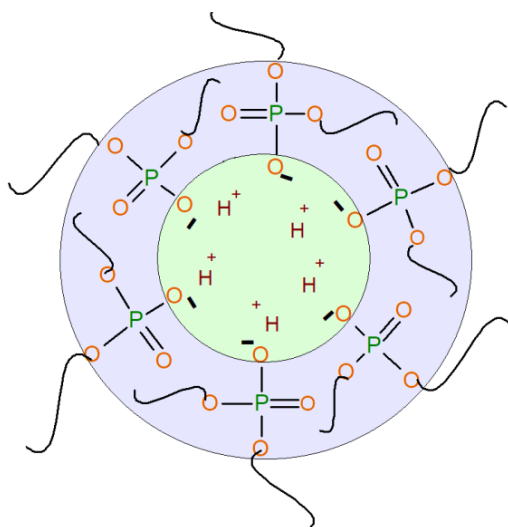
# SYNTHESIS AND STUDY OF ORGANOPHOSPHORUS POLYURETHANE IONOMERS

*Sazonov O.O., Zakirov I.N., Latul A.V., Davletbaeva I.M.*

Kazan National Research Technological University, Kazan, Russia  
Postgraduate student, profile «Technology and processing of polymers and composites»  
[sazonov.oleg2010@gmail.com](mailto:sazonov.oleg2010@gmail.com)

Polyurethanes are a wide range of materials with different physical and mechanical properties, making them useful for a variety of applications such as elastomers or biomaterials. The addition of ionic groups to the polyurethane backbone opens the way for new applications where ionic groups can act as crosslinking agents that significantly alter the mechanical and thermal properties of materials [1].

The etherification of *ortho*-phosphoric acid with triethanolamine and polyoxypropylene glycol is studied. The reaction process is accompanied by the formation of branched amino ethers of *ortho*-phosphoric acid terminated by hydroxyl groups. A specific feature of the chemical structure of the compounds obtained is the existence of ion pairs in their structure separated in space [2]. The reaction of the etherification of *ortho*-phosphoric acid with glycols becomes possible with tertiary amines. The amino ethers of *ortho*-phosphoric acid are investigated as a polyol component for the synthesis of polyurethanes with high adhesion characteristics and strength properties. The experimental results presented allow us to relate polyurethanes obtained based on *ortho*-phosphoric acid amino ethers to polymers of ionomeric nature. It was found that, depending on the reaction conditions and the nature of the isocyanates used, AEPA-PU can be used as protective coatings, pervaporation and vapor-permeable membranes, and also as a substrate for lithium-conducting gel electrolytes [3-4]. It is shown that the processes of mass transfer are caused by the formation of ionic clusters in the composition of AEPA-PU according to the given scheme (Figure).



**Figure.** Scheme of the formation of ionic clusters in the composition of AEPA-PU

## References

- [1] Jaudouin O., Robin J.-J., Lopez-Cuesta J.-M., Perrin D., Imbert C. *Polymer Int.* **2012**, *61*, 495–510
- [2] Davletbaeva I.M., Sazonov O.O., Fazlyev A.R., Davletbaev R.S., Efimov S.V., Klochkov V.V., *RSC Advances* **2019**, *9*, 18599-18608
- [3] Davletbaeva I.M., Sazonov O.O., Fazlyev A.R., Zakirov I.N., Davletbaev R.S., Efimov S.V., Klochkov V.V. *Polymer Science. Series A.* **2020**, *62*, 337–349
- [4] Davletbaeva I.M., Sazonov O.O., Zakirov I.N., Gumerov, A.M., Klinov A.V., Fazlyev A.R., Malygin A.V. *Polymers* **2021**, *13*, 1442.

Acknowledgements. This work was supported by the Russian Science Foundation (grant no. 19-19-00136)

ELECTROCHEMICAL BIOSENSOR BASED ON NANOSIZED POLYMER-ENZYME FILMS  
COMPOSED OF P(NIPAM-co-DMAPMA) MICROGEL AND GLUCOSE OXIDASE

*Shalybkova A.A., Sharifullin T.Z., Sigolaeva L.V., Pergushov D.V.*

Department of Chemistry, M.V. Lomonosov Moscow State University, Moscow, Russia  
Student  
[annyshal@mail.ru](mailto:annyshal@mail.ru)

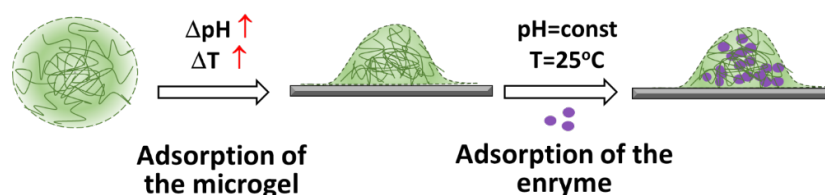
The efficient coupling of biomolecules, in particular enzymes to surface of electrodes within man-made devices is a crucial aspect when engineering (bio)analytical sensors. Generally, efficiency of enzyme immobilization determines the quality of an analytical device, its sensitivity, and eventually its market competitiveness. Among the wide variety of known methods of enzyme immobilization, the modification of the sensor surface by “smart” polymer microgels [1], which are able to significantly quickly and reversibly change their properties when environmental conditions vary, is very promising.

In particular, pH- and thermosensitive copolymer microgels poly(*N*-isopropylacrylamide-co-*N*-[3-(dimethylamino) propyl]methacrylamide), P(NIPAM-co-DMAPMA), are of particular interest, being composed of thermosensitive PNIPAM (major component) and incorporating pH-sensitive (chargeable) tertiary amino groups of DMAPMA as a comonomer [2-5]. In a deprotonated (uncharged) and collapsed state such microgels possess high adhesion to hydrophobic surfaces, while in a swollen and protonated (charged) state, even being adsorbed they are able to bind considerable amounts of oppositely charged enzymes, and at the same time, provide a favorable water-rich microenvironment for the bound biomolecules.

This work examines the adsorption of P(NIPAM-co-DMAPMA) onto solid hydrophobic surfaces, the subsequent capacious loading of the adsorbed microgel with glucose oxidase (GO), and the stability of the surface-bound microgel-enzyme complex under various pH- and salt conditions, which could trigger a release of GO from the adsorbed P(NIPAM-co-DMAPMA) microgel.

The stimuli-responsive properties of the P(NIPAM-co-DMAPMA) microgel in aqueous solutions were characterized by potentiometric titration, dynamic light scattering, and laser microelectrophoresis. The peculiarities of the adsorptive behavior of the microgel and its electrostatic interaction with the GO were revealed by quartz crystal microbalance with dissipation monitoring upon the subsequent deposition of the components onto surface of gold-coated quartz crystals.

The revealed optimal conditions were further applied for the two-stage fabrication of P(NIPAM-co-DMAPMA)/GO films on the surface of planar graphite electrodes (preliminarily modified with manganese dioxide nanoparticles to impart them sensitivity to hydrogen peroxide) (figure 1). The analytical performance of the fabricated constructs as amperometric biosensors for quantification of glucose was examined and the analytical characteristics (sensitivity, linear range, limit of detection) for glucose assay as well as the operational stability of the developed electrochemical biosensors were determined.



**Figure 8.** Two-stage fabrication of P(NIPAM-co-DMAPMA)/GO films on the surface of planar graphite electrodes.

#### References

- [1] F.A. Plamper, W. Richtering *Acc. Chem. Res.* **2017**, *50*(2), 131-140.
- [2] L.V. Sigolaeva, S.Yu. Gladyr, A.P.H. Gelissen, O. Mergel, D.V. Pergusov, I. N. Kurochkin, F. A. Plamper, W. Richtering *Biomacromolecules.* **2014**, *15*(10), 3735.
- [3] L.V. Sigolaeva, O. Mergel, E.G. Evtushenko, S.Yu. Gladyr, A.P.H. Gelissen, D.V. Pergusov, I. N. Kurochkin, F. A. Plamper, W. Richtering *Langmuir.* **2015**, *31*(47), 13029.
- [4] L.V. Sigolaeva, S.Yu. Gladyr, O. Mergel, A.P.H. Gelissen, M. Noyong, U. Simon, D.V. Pergushov, I. N. Kurochkin, F. A. Plamper, W. Richtering *Analytical Chemistry.* **2017**, *89*(11), 6091.
- [5] L.V. Sigolaeva, D.V. Pergushov, M. Oelmann, S. Schwarz, M. Brugnioni, I.N. Kurochkin, F. A. Plamper, A. Fery, W. Richtering. *Polymers.* **2018**, *10*(7), 791.

Acknowledgements. This work was supported by the Russian Foundation for Basic Research (project No 19-08-00483-a).

## BIOMIMETIC POLYMER COATINGS FOR BIOACTIVE ION RELEASE

*Shchurkina M.A.<sup>1</sup>, Mikhailova M.A.<sup>1</sup>, Kolchanov D.S.<sup>1</sup>, Kuchur O.A.<sup>1</sup>,  
Morozova S.M.<sup>2</sup>, Chrishtop V.V.<sup>1</sup>, Morozov M.I.<sup>1</sup>*

<sup>1</sup>ITMO University, SCAMT International Science Center, Saint Petersburg, Russia

<sup>2</sup>Bauman Moscow State Technical University, Moscow, Russia

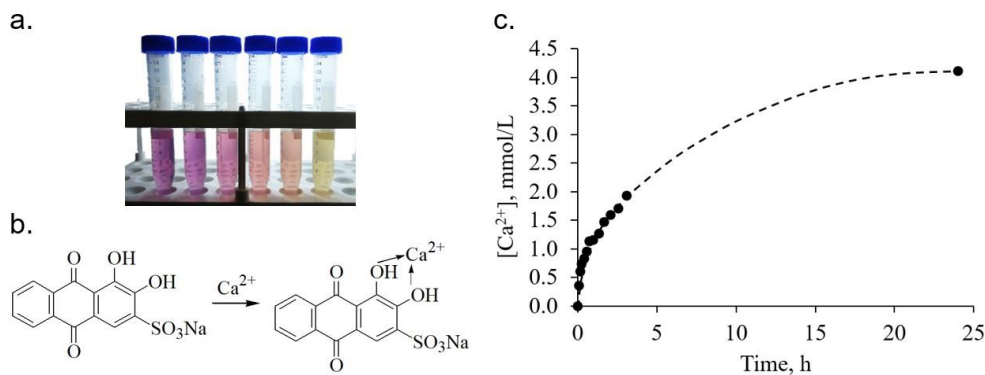
Student

[shchurkina@scamt-itmo.ru](mailto:shchurkina@scamt-itmo.ru)

Calcium ions ( $\text{Ca}^{2+}$ ) are important in biological processes, especially at the level of intracellular and intercellular communications. They control a variety of processes important for injury repair and many other life essential processes. The mechanisms of intercellular communication have not yet been studied enough [1-3]. A thorough understanding of these mechanisms is essential for effective wound healing [1].

In this study, functional composites based on calcium modified sodium alginate and polyacrylic acid were synthesized and investigated as a source of bioactive calcium ions. The composite thin films were synthesized and deposited on a conducting FTO glass by spin-coating. The primary characterization of the films included scanning and atomic force microscopy (SEM and AFM), EDX analysis, and MTT cytotoxicity assay. The films based on sodium alginate showed a flat surface and a relatively low thickness (70 nm), while the ones based on polyacrylic acid were thicker (~200 nm) with a surface roughness. The calcium loading capacity of up to 3.31 for sodium alginate and 5.6 wt.% for polyacrylic acid was evaluated by EDX analysis. Both composites have shown a relatively low cytotoxicity, with the survival rate of dermal fibroblast cells above 80% (MTT assay).

The release of calcium ions was experimentally evaluated as illustrated in Figure 1. Depending on time, temperature, and applied external electric field, the migration of calcium ions from the film to the adjacent aqueous solution was determined by spectrophotometry. An apparent colorimetric manifestation (Fig. 1a) was achieved using alizarin red S as an indicator on  $\text{Ca}^{2+}$  (Fig 1b). A composite film based on calcium modified sodium alginate with thickness 70 nm and surface area 3.14  $\text{cm}^2$  has demonstrated the saturation limit of free calcium release in 6 ml of aqueous media reaching the concentration of 4.11 mmol/L within 24 hours (Fig. 1c). This value is comparable with the normal calcium concentration in widely used basal media for supporting the growth of many cells, such as DMEM.



**Figure 1.** (a) solutions of calcium alizarinate for standard curve; (b) scheme of calcium ion capture by alizarin red S; (c) diffusion of calcium ions from the composite film based on calcium modified sodium alginate in aqueous media.

Thus, the functional properties, such as thin and flat morphology, in combination with a low toxicity and an appropriate capacity for calcium loading and release make the spin-coated films based on sodium alginate prospective for developing compact biomimetic devices with the controllable calcium release.

### References

- [1] Ghilardi S.J., O'Reilly B.M., Sgro A.E. *WIREs Syst Biol Med.* **2020**, 12(3), 1–26
- [2] Janssen L.J., Mukherjee S., Ask K. *Am. J. Respir. Cell Mol. Biol.* **2015**, 53, 135–148
- [3] Smedler E., Uhlén P. *Biochim. Biophys. Acta - Gen. Subj.* **2014**, 1840, 964–969

Acknowledgements. This work was supported by the Russian Science Foundation (project No 19-19-00433).

# BIOFUNCTIONAL AND BIODEGRADABLE INORGANIC-ORGANIC COMPOSITES FOR THE TREATMENT OF BONE CANCER AND BONE REGENERATION

*Shikhova A.M.*<sup>1</sup>, *Averianov I.V.*<sup>2</sup>, *Dobrodumov A.V.*<sup>2</sup>, *Gofman I.V.*<sup>2</sup>, *Voinova V.V.*<sup>3</sup>, *Zhdanov A.P.*<sup>3</sup>,  
*Korzhikova-Vlakh E.G.*<sup>2,4</sup>, *Stepanova M.A.*<sup>2</sup>

<sup>1</sup>Saint Petersburg State Institute of Technology, Saint Petersburg, Russia

<sup>2</sup>Institute of Macromolecular Compounds of the Russian Academy of Sciences, Saint Petersburg, Russia

<sup>3</sup>Kurnakov Institute of General and Inorganic Chemistry of the Russian Academy of Sciences, Moscow, Russia

<sup>4</sup>Institute of Chemistry, Saint Petersburg State University, Saint Petersburg, Russia

Student

shkh\_asya@mail.ru

Today, the main direction of treatment for bone tissue malignant diseases is the surgical excision of the tumor. However, it is very difficult to achieve their complete removal in practice, which can lead to relapses and the appearance of metastasis. In addition, it is important to reduce the volume of surgical intervention and ensure the bone defect restoration, thereby increasing the patient's standard of living [1]. Thus, the production of biodegradable scaffolds for bone tissue regeneration, containing anticancer drugs, is a challenge for modern medicine.

Boron-neutron capture therapy (BNCT) is of great interest in the fight against cancer. This method is based on the use of compounds containing the <sup>10</sup>B isotope capable of absorbing a neutron with the subsequent decay of the formed <sup>11</sup>B isotope with the release of a large amount of energy, which leads to the destruction of the cell [2].

The aim of this work is to develop an approach for the production of biodegradable materials based on polylactide (PLA) and polycaprolactone (PCL) containing *closo*-borates as potential BNCT agents. Compounds of this type are promising because they contain 10 or 12 boron atoms in 1 molecule and they can be modified by introducing various substituents, thereby ensuring the selectivity of their accumulation in tumor cells. Two approaches for obtaining such materials were tested during the study. The first consists in the preparation of PLA and PCL films, their modification by the formation of carboxyl (partial hydrolysis) and amino groups (introduction into the polymer mass and covalent bonding of different amine-containing compounds) on the films surface and further adsorption on them of *closo*-borates with different substituents. The second involves the formation of PLA and PCL films doped with *closo*-borates in various concentrations (1, 3, 5 wt%). The processes of non-covalent interactions of the modified and unmodified PLA/PCL and various substituted *closo*-deca- and *closo*-dodecaborate anions, the morphology of the materials obtained (optical and scanning electron microscopy), their mechanical properties, the kinetics of materials degradation and the release of boron cluster anions in simulating physiological conditions solution were studied. The formation of a *closo*-borates layers on the materials surface was confirmed by IR spectroscopy, and the adsorption and release processes using <sup>1</sup>H and <sup>11</sup>B NMR spectroscopy were monitored.

All prepared materials were characterized by acceptable for bone tissue engineering mechanical properties. The best results for use in BNCT were obtained for PLA and PCL materials containing 5% *closo*-borates in their mass. Both types of materials were characterized by a burst release of *closo*-borate on the first day of about 75% for PLA and 55% for PCL, followed by its gradual release for a further 2 months. Slower degradation and release were observed in the case of materials based on PCL. Thus, materials with different mechanical properties, suitable for both BNCT at different points in time and bone regeneration were developed.

## References

- [1] Cojocaru F.D., Balan V., Popa I.M. et al. *Medicina* **2019**, *55*, 153  
[2] Hirose K., Konno A., Hiratsuka Ju. et al. *Radiother. Oncol.* **2021**, *155*, 182-187

Acknowledgements. This work was supported by the Russian Foundation for Basic Research (project No 20-33-70217). The Interdisciplinary Center for Nanotechnology of the SPbU Research Park is acknowledged for scanning electron microscopy.

## DETERMINATION OF BOLTORN-BASED BLOCK COPOLYMERS STRUCTURE BY NMR METHODS

*Shpotya V.A.*<sup>1</sup>, *Perepukhov A.M.*<sup>1</sup>, *Maksimych A.V.*<sup>1</sup>, *Gomzyak V.I.*<sup>2</sup>, *Chvalun S.N.*<sup>2</sup>

<sup>1</sup>Moscow Institute of Physics and Technology (National Research University), Moscow, Russia

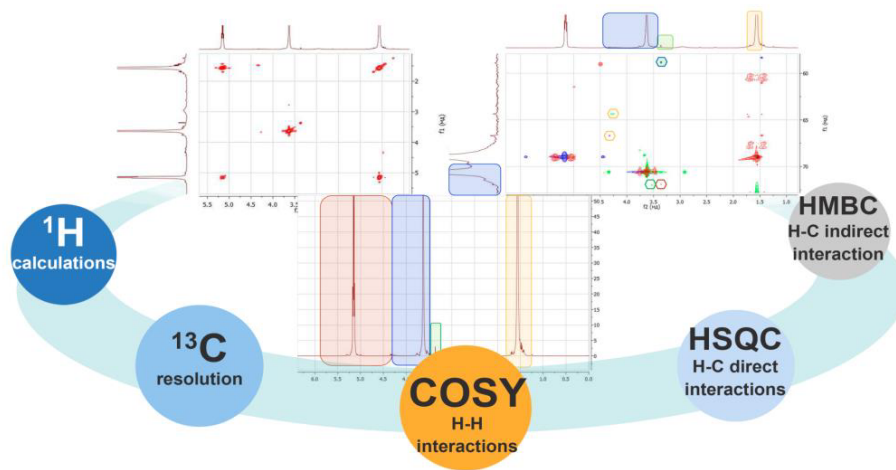
<sup>2</sup>MIREA - Russian Technological University, Moscow, Russia

PhD student

[valeriya.shpotya@phystech.edu](mailto:valeriya.shpotya@phystech.edu)

Personalized medicine, and particularly targeted drug delivery, is one of the most rapidly evolving fields today. Nanocarriers for delivery enhance bioactive component solubility and prevent them from premature release. The use of such carriers results in lower medication intake and, as a result, lower toxicity. The usage of biodegradable and biocompatible block copolymers ensures the safety of nanocontainers [1-2]. Block copolymers of hyperbranched polyester 2,2-dimethylol propionic acid (BOLTORN) with polylactide were investigated in this work.

The irregular structure of the base hyperbranched polyester, the ability to modify the lengths of polylactide chains, and the great contrast of the signal intensity of the internal and connecting units distinguish the studied block copolymers. All of these properties may be observed using NMR spectroscopy techniques, however such systems need a unique set of experiments to offer an accurate and trustworthy description of the block copolymer structure. The DOSY diffusion experiment was used to determine the number of components in samples of block copolymers with varying lengths of polylactide chains. They were then investigated using one-dimensional (<sup>1</sup>H and <sup>13</sup>C) experiments, homonuclear two-dimensional experiments (COSY/TOCSY), and heteronuclear two-dimensional experiments (HSQC, HMBC) (Fig. 1). The use of such a series of experiments allowed the one-dimensional spectra to be unambiguously interpreted and used for numerical estimates of the average length of polylactide chains and the ratio of BOLTORN vacancies to the number of polylactide chains.



**Figure 1.** Sequence of NMR spectroscopy experiments for block copolymer structure determination

The analysis produced numerical values for the properties of block copolymers in nanocontainers for targeted drug delivery, as well as the optimal sequence of NMR spectroscopy tests for the characterization of such molecules. It is planned to broaden the usage of the gained technology to block copolymers of varied compositions in the future, as well as to enhance the processing procedures of some of the tests.

### References

- [1] Du F., Hönzke S., Neumann F., Keilitz J., Chen W., Ma N., et al. *J. Control Release* **2016**, *242*, 42–49
- [2] Torchilin V.P. *Pharm Res.* **2007**, *24(1)*, 1–16



## PROLONGED DRUG DELIVERY SYSTEM BASED ON POLYVINYL ALCOHOL

*Shurshina A.S., Chernova V.V., Kulish E.I.*

Bashkir State University, Ufa, Russia  
[anzhela\\_murzagil@mail.ru](mailto:anzhela_murzagil@mail.ru)

Today, most dosage forms are made using excipients. These include polymers that act as prolongers of the action of drugs. The use of prolonged dosage forms makes it possible to avoid the negative phenomena that arise during the rapid elimination of drugs from the body. These include a sharp fluctuation in the concentration of drugs in the body, the appearance of forms of microorganisms resistant to these substances, toxicity, allergic reactions, irritation, etc.

One of the promising polymers for use as prolongers is polyvinyl alcohol. The prolonging effect of polyvinyl alcohol is due, firstly, to the high viscosity of polymer solutions, which in turn should ensure slow diffusion of the drug. Secondly, the ability of functional groups of the polymer to form complex compounds with drugs through hydrogen bonds. It is assumed that if in dilute solutions polyvinyl alcohol is capable of interacting with drugs, then this fact will provide a high level of prolongation in the transition from liquid to soft dosage forms. However, an increase in the concentration of the polymer in solution is accompanied not only by an increase in viscosity, which could contribute to prolongation, but also by the structuring of the polymer taking place. In turn, structure formation is accompanied by a decrease in the availability of polymer units for interaction with the drug, which makes the prolongation effect not so obvious.

In this regard, the purpose of this work was to assess the ability to prolong the action of polyvinyl alcohol in relation to the drug release when going from dilute to more concentrated solutions. The drug was lidocaine.

The interaction of the polyvinyl spiral with the drug was studied by UV spectroscopy. Analysis of the data showed that a complex of medium stability is formed, which, in principle, is capable of providing a certain level of prolongation due to the fixation of the drug on the polymer chain.

It was found that an increase in the viscosity of the polymer in solution caused by an increase in its concentration leads to a significant decrease in the amount of the drug firmly fixed on the polymer matrix. Since it is the adduct of the polyvinyl alcohol-drug interaction that provides the slow release of the drug from the polymer solution, a decrease in its amount leads to the fact that an increase in the prolonging action is not observed with an increase in the concentration of polyvinyl alcohol in the solution.

It is argued that in the transition from solutions to polymer films, the rate of drug release is determined not only by the amount of the drug firmly attached to the polymer matrix, but also by the structure of the polymer matrix. The lower the density of the polymer film, the greater the diffusion coefficient of the release of the drug from the film.

Thus, in the course of assessing the ability to prolong the action of polyvinyl alcohol, it was shown that using some prolongation techniques, it is possible to achieve a targeted regulation of the rate of release of drugs from polymer dosage forms.

# APPLICATION OF ALUMINUM DIKETONATES IN POLYMERIZATION CATALYSIS $\epsilon$ -CAPROLACTONE

*Solovyova Y.V.*<sup>1</sup> *Puzyrev I.S.*<sup>2</sup> *Pestov A.V.*<sup>2</sup>

<sup>1</sup>Ural Federal University, Yekaterinburg, Russia

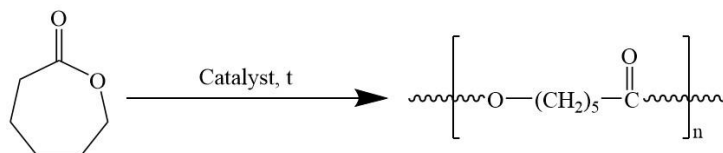
<sup>2</sup>Postovsky Institute of Organic Synthesis, Ural Branch of Russian Academy of Sciences, Yekaterinburg, Russia  
Student

[yana-soloveva-1998@mail.ru](mailto:yana-soloveva-1998@mail.ru)

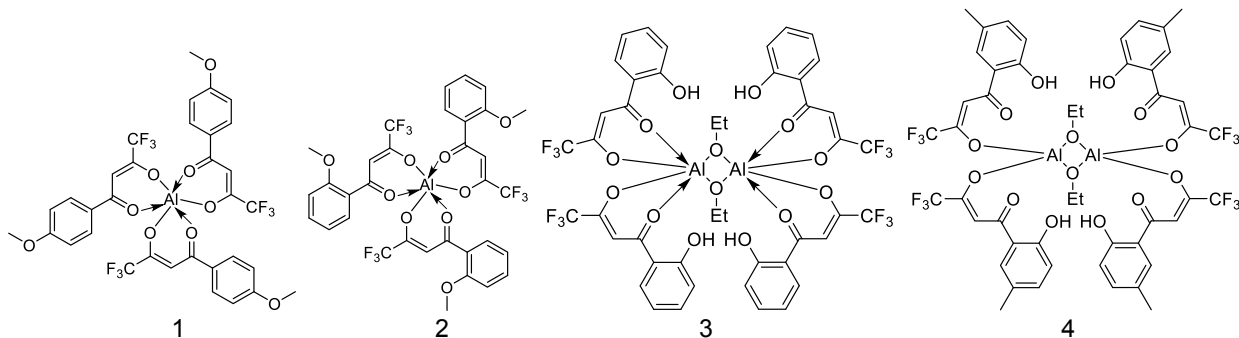
Currently, biodegradable polymers are widely used as a medical material [1]. Another significant application of biodegradable polymers is the possibility of their use as packaging materials [2].

Poly( $\epsilon$ -caprolactone) is a biodegradable and biocompatible semi-crystalline polyester that is FDA approved for biomedical applications. In addition to bio-characteristics, the polymer has high processability, low cost, heat resistance, excellent moisture resistance, chemical and oil resistance [3]. The main method for preparing poly( $\epsilon$ -caprolactone) is ring-opening polymerization of the corresponding monomer. The search and development of effective catalytic systems for this process is an important stage in the creation of a material with controlled characteristics and a wide range of applications.

In the present work, we studied the catalytic activity of new complex compounds of aluminum with fluorinated aromatic  $\beta$ -diketonates in the polymerization of  $\epsilon$ -caprolactone. Dodecyl alcohol was the initiator of the process. The resulting samples were analyzed by <sup>1</sup>H NMR and GPC.



**Figure 1.** Scheme of polymerization of  $\epsilon$ -caprolactone



**Figure 2.** Structures of complex aluminum compounds

The studied complex aluminum compounds are effective catalysts for bulk polymerization. The process is controlled and changing the monomer / initiator ratio allows proportional changes in the degree of polymerization of the product. It was found that mononuclear aluminum complexes catalyze polymerization more efficiently than binuclear ones.

## References

- [1] Espinoza S. M., Patil H.I., Martinez E. S. M., Pimentel R. C. *Polym. Mat. Polym. Biomat.* **2019**, 69, 85–126
- [2] Zhonga Y., Godwinb P., Jina Y., Xiaob H. *Ad. Ind. Engin. Polym.* **2020**, 3, 27–35
- [3] Sangroniz A., Zhu J.-B., Tang X., Etxeberria A., Chen E.-Y., Sardon H. *Nature Communications* **2019**, 10, Article number: 3559.

# PYRIDYLPHENYLENE DENDRONS AS EFFICIENT PALLADIUM LIGANDS FOR C-C CROSS-COUPLING REACTIONS

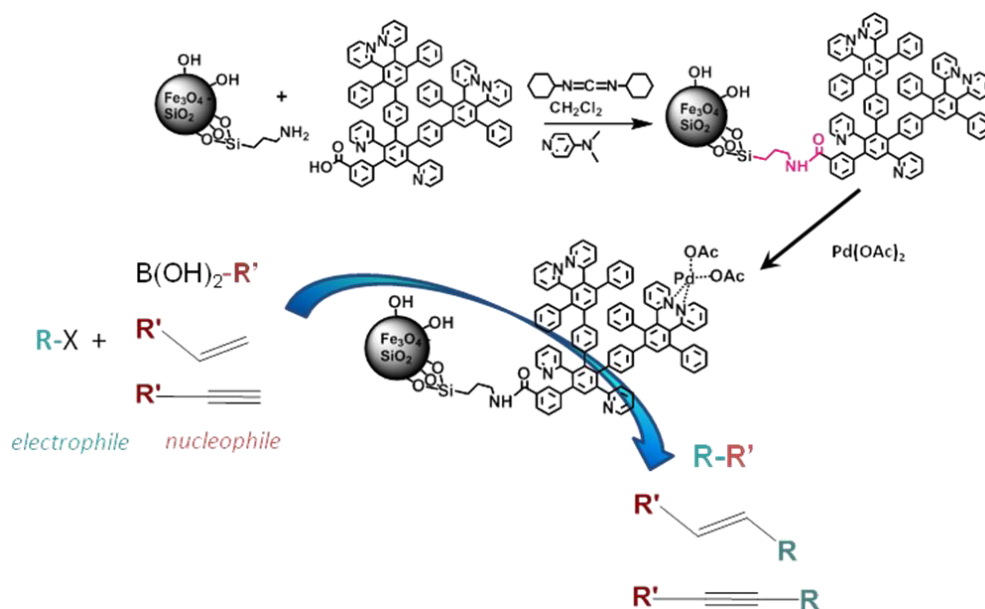
*Sorokina S.A.<sup>1</sup>, Kuchkina N.V.<sup>1</sup>, Shifrina Z.B.<sup>1</sup>.*

<sup>1</sup>A.N. Nesmeyanov Institute of Organoelement Compounds of RAS, Moscow, Russia  
sorokinas@ineos.ac.ru

Carbon-carbon cross-coupling reactions are among the most useful synthetic tools for construction of new molecules. The three most important processes, the Heck reaction, the Suzuki-Miyaura coupling, and the Sonogashira reaction catalyzed by palladium have been abundantly used in the synthesis of pharmaceuticals and bioactive compounds. However, the absence of universal reaction conditions for each catalytic system and the drawbacks of industrial catalysts determine the search for novel catalytic systems. Modern catalysts should provide high activity and selectivity, be reusable, air stable, and avoid the contamination of the final product with a catalytically active metal.

We have developed the design of affordable and effective organic-inorganic hybrid systems. Their construction is based on the idea of a nanocomposite catalyst consisting of a mesoporous support containing magnetic nanoparticles, covalently bound to an organic dendritic block, and complexes of transition metals or metal nanoparticles stabilized by dendritic ligands. In this case, metal complexes or nanoparticles are responsible for the catalytic properties of the composite, while the magnetic component provides a quick and economical separation of the catalyst for repeated use.

The developed systems showed high activity and selectivity in C-C addition reactions (Sonogashira, Suzuki, Heck) due to the use of a specific ligand environment (pyridylphenylene dendrons) for the coordination of metals. The pyridyl groups of the dendron coordinate  $\text{Pd}(\text{CH}_3\text{COO})_2$ , providing the formation of catalytically active compounds  $\text{Pd}^{2+}$ ,  $\text{Pd}^0$ , as well as Pd nanoparticles [1, 2]. At the same time, the open structure of the dendrons enables easy access for the substrate molecules to the catalytic centers, while the rigid and bulky architecture prevents metal leaching and ensures high stability and activity of the catalyst after magnetic separation. The magnetic separation and reuse of the catalyst aid to reduce the price of target products, reduce energy and material costs, and diminish the residual contamination of molecules by the catalyst.



**Figure 1.** Depiction of cross-coupling reaction catalyzed by hybrid organo-inorganic palladium catalysts with dendritic ligands

## References

- [1] Kuchkina N.V., Haskell A., Sorokina S.A., Torozova A.S., Nikoshvili L.Zh, Sulman E.M., Stein B.D., Morgan D.Gene, Bronstein L.M., Shifrina Z.B.. *React Funct Polym*, **2020**. 151, 104582
- [2] Sorokina S.A., Kuchkina N.V., Lawson B.P., Krasnova I.Yu, Nemygina N.A., Nikoshvili L.Zh, Talanova V.N., Morgan D.G., Sulman E.M., Bronstein L.M., Shifrina Z.B. *Appl Surf Sci*, **2019**. 488, 865–873

Acknowledgements. This work was supported by the Russian Science Foundation (project No 18-13-00332).

# GRADIENT REFRACTIVE INDEX IN IONIC POLYMERS BASED ON MODIFIED DIMETHYL DIALLYL AMMONIUM CHLORIDE

*Statsenko T.G.*<sup>1,2</sup>, *Ermolaev G.A.*<sup>3</sup>, *Gets D.S.*<sup>2</sup>, *Eliseev I.E.*<sup>4</sup>, *Volkov V.S.*<sup>3</sup> and *Morozova S. M.*<sup>1,2</sup>

<sup>1</sup>Bauman Moscow State Technical University, Moscow, Russia

<sup>2</sup>ITMO University, Megafacultet of nanophotonics and metamaterials, Saint Petersburg, Russia

<sup>3</sup>Center for Photonics and 2D Materials, Moscow Institute of Physics and Technology, Moscow, Russia

<sup>4</sup>Laboratory of Renewable Energy Sources, Alferov University, Saint Petersburg, Russia

PhD Student

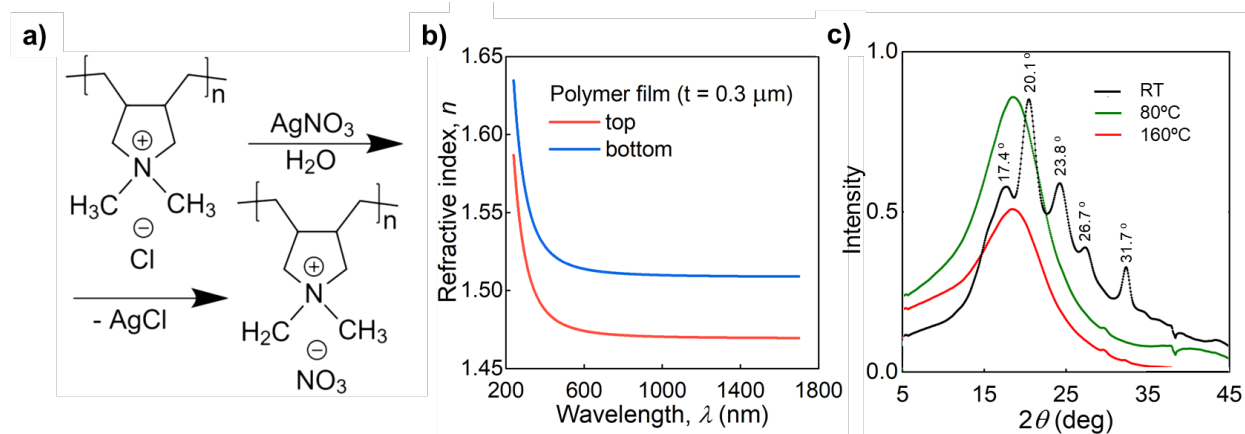
[tatianastatsenko@yandex.ru](mailto:tatianastatsenko@yandex.ru)

In contrast to constant refractive index, Gradient Refractive Index (GRIN) provides greater control over the path of light rays by changing the refractive index throughout the entire volume of the device. Increasing the refractive index by shaping the refractive index of a gradient is a strategy inspired by nature [1]. Indeed, animal's eyes have a relatively small refractive index in the range of 1.33 - 1.52, while astounding image quality. The creation of materials with a gradient refractive index is a promising task in the development and minimization of optical objects: microlenses, waveguides [1,2].

Previously, we found that poly(ionic liquid)s could possess a gradient refractive index in thin films. Among series of polymers based on poly(dimethyl diallyl diammonium) cation with different counteranions, only PIL-NO<sub>3</sub> possess a GRIN effect (Fig. 1a.). For 300 nm thin film prepared by spin-coating it was shown by ellipsometry that the refractive index of the bottom of the film is higher than the top (Fig. 1b). We suppose that the gradient is related to the crystallinity of PIL-NO<sub>3</sub>.

Melting temperature of this polymer is 58°C according to differential scanning calorimetry, which was also confirmed by X-ray study at different temperature (Fig. 1c). Sample PIL-NO<sub>3</sub> stored at room temperature have crystallinity 44%. Other samples, which were heated above crystallization temperature (at 80°C and 160°C), then immediately cooled by liquid nitrogen, was amorphous.

To further study of the effect of crystallinity of PIL-NO<sub>3</sub> on its RI films with a thickness of 300 nm to 2 μm were obtained on a silicon substrate covered by 10 nm Cr then 20 nm of Au. The films were studied by X-ray reflectometry and ellipsometry at temperatures above and below polymer crystallization.



**Figure 1.** Investigation of structure and properties PILs film and microlenses based on PIL-NO<sub>3</sub>: a - synthesis scheme; b - the distribution of the gradient of the refractive index in the film; c - 2D X-ray diffraction images;

Thus, a comparison of the data of X-ray diffraction reflectometry and ellipsometry of thin polymer films on contrast substrates showed that the gradient of the refractive index depends on the degree of crystallinity of the polymer.

## References

[2] Jang, Wontae, et al. *Science advances*. **2020**, 6.28, eabb5320

Acknowledgements. This work was supported by the Russian Science Foundation (project No. 21-79-20113) and Ministry of Science and Higher Education of the Russian Federation (project No. MK-5116.2021.4). This work was in part carried out using equipment of the SPbU Resource Centre for X-ray Diffraction Studies and Chemical Analysis and Materials Research Centre.

# REVERSIBLE ADDITION-FRAGMENTATION CHAIN TRANSFER POLYMERIZATION OF POLYMETHACRYLIC ACID FOR THE DRUG DELIVERY

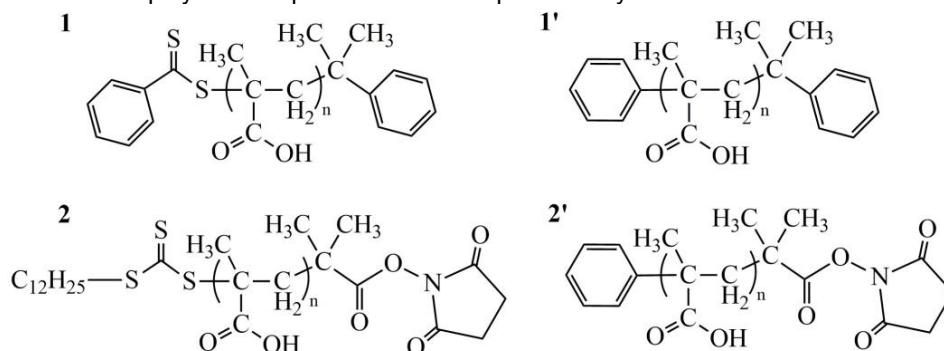
*Tarankova K.A.<sup>1</sup>, Grigoreva A.O.<sup>1</sup>, Zaitsev S.D.<sup>1</sup>*

<sup>1</sup>Lobachevsky State University, Nizhnij Novgorod, Russia  
Student  
[csenia7@gmail.com](mailto:csenia7@gmail.com)

Polymeric drug delivery systems are actively used in pharmacy. They increase the circulation time and improve the process of drug uptake by tumor cells due to polymer's high values of molecular weight (MW) [1]. In turn, poly(meth)acrylic acids have antitumor and antiviral properties due to their MW characteristics.

Reversible addition-fragmentation chain transfer (RAFT) polymerization allow to control process of polymer synthesis. Among the methods of controlled living radical polymerization RAFT process is more available, effective, versatile and also has successfully used to prepare a wide range of polymers [2-3].

In this work we synthesized polymers of methacrylic acid by RAFT polymerization. Polymerization was carried out in the presence of 2-phenylpropan-2-yl Benzodithioate and 2-(Dodecylthiocarbonothioylthio)-2-methylpropionic acid N-hydroxysuccinimide ester as RAFT agents. Polymerization was characterized by the linear increase of number-average molar mass with the rise of conversion in both cases. Obtained polymers have low polydispersity index. Two models of polymethacrylic acids were investigated: containing the terminal group of the RAFT agent and without it for further investigation of the effect of the polymer chain structure on cytotoxicity (Fig.1). The samples were heated with excess of Benzoyl Peroxide (PB) to remove the agent's groups. To determine the polymer composition <sup>1</sup>H NMR spectrometry were used.



**Figure 1.** Polymethacrylic acid synthesized in the presence of 2-phenylpropan-2-yl Benzodithioate (1) and 2- (Dodecylthiocarbonothioylthio)-2-methylpropionic acid N-hydroxysuccinimide ester (2) as RAFT agents before and after heating with excess of PB (1' and 2' respectively)

## References

- [1] Shayne Cox Gad. New Jersey: J.Wiley & Sons **2008**, 1370
- [2] Barner Kowolik C. *New York: Wiley Interscience* **2008**
- [3] Moad G., Rizzardo E., Thang S.H. *Polymer* **2008**, 49, 1079

# HYALURONIC ACID-graft-POLY(L-LYSINE) COPOLYMERS: SYNTHESIS AND TESTING AS siRNA DELIVERY SYSTEMS

Teterina P.S.<sup>1</sup>, Osipova O.M.<sup>1</sup>, Korzhihova-Vlakh E.G.<sup>1,2</sup>, Korzhihkov-Vlakh V.A.<sup>1</sup>

<sup>1</sup>Saint Petersburg State University, Saint Petersburg, Russia

<sup>2</sup>Institute of Macromolecular Compounds RAS, Saint Petersburg, Russia

Student

[teterinapolina@gmail.com](mailto:teterinapolina@gmail.com)

Therapeutic targets of small molecules make up only 2-5% of the human genome [1]. Therefore, there is a need to create alternative classes of therapeutic agents. At the same time, the improved understanding of the "genetic reasons" of different diseases and completion of the human genome project has led to the discovery of new therapeutic agents that can specifically alter the expression of disease-associated genes. Thus, it is necessary to develop new efficient delivery systems of such gene expression blocking agents as small interfering RNAs (siRNAs). For effective transfection, it is necessary to balance between extracellular protection of nucleic acids (NA), effective penetration into cells and effective intracellular release of NA. An approach based on the formation of interpolyelectrolyte complexes (IPECs) of NA with polycations (chitosan and poly(L-lysine)) in the presence of a competing polyanions, such as heparin and hyaluronic acid, was recently developed in the Laboratory of Biomedical Chemistry [2]. This approach promotes easier release of NA and reduce the toxicity of delivery systems. At the same time, the efficiency of transfection was sufficiently high.

Current study was devoted to the preparation of a hyaluronic acid-graft-poly(L-lysine) graft copolymer and study of its ability to act as a delivery system for nucleic acids, namely siRNAs. Thus, an attempt was made to combine the polycation and polyanion into a single molecule, which is promising from the point of view of increasing the efficiency of the release of delivered nucleic acids into the cytoplasm, as well as from the point of view of reducing the toxicity of delivery systems.

In the presented work an original method for the synthesis of a graft copolymer hyaluronic acid-graft-poly(L-lysine) was developed. The structure of obtained copolymer was proved and its properties were investigated. For the synthesis of the target copolymer, the "grafting on" strategy was chosen, using the strategy of strain promoted azide-alkyne cycloaddition. The efficiency of siRNA binding with the obtained graft copolymer and the release of a model oligonucleotide were investigated. It was found that the obtained graft copolymers are less cytotoxic than poly(L-lysine) and can penetrate into cells. The resulting delivery systems have shown efficacy in gene knockdown experiments.

## References

[1] Rask-Andersen M. *Annual Review of Pharmacology and Toxicology*. **2014**, 54(1), 9-26.

[2] Pilipenko I. et al. *Pharmaceutics*. **2019**, 11(7), 317.

Acknowledgements. This work was supported by the Russian Science Foundation (project No 19-73-10045). Authors are grateful to Molecular and Cell Technologies and Magnetic Resonance Research Centers of research park of SPbU.

# DRIED "ARQUAD 2HT-75" AS A POLYETHYLENE-SMECTITE COMPATIBILIZER

*Tikhomirov V.A.<sup>1,2</sup>, Gerasin V.A.<sup>1,2</sup>*

<sup>1</sup>Mendeleev University of Chemical Technology of Russia, Moscow, Russia

<sup>2</sup>A.V.Topchiev Institute of Petrochemical Synthesis, Moscow, Russia

Post-graduate

[hasn200@mail.ru](mailto:hasn200@mail.ru)

Hydrophobic polymers have very little tendency to interact with mineral surfaces of hydrophilic clay, so there is no driving force for unmodified clay dispersion in polymer matrix. The 'organoclay strategy' consists in making the clay mineral compatible with the polymer, by introducing hydrophobic surfactants (e.g. quaternary ammonium salts). The opposite approach can also be adopted, making the polymer compatible with the clay mineral, e.g. grafting hydrophilic groups on polymer chains. Thus, polar moieties such as maleic anhydride, acrylic acid or linear alcohol chains might be introduced into polystyrene (PS) [1], allowing for the preparation of the corresponding polymer-clay nanocomposite (PCN) by melt processing.

Maleic anhydride (MA) has long been considered a particularly suitable compatibilizer for modification of major non-polar polymers, specifically polyolefins [2], and even some polar ones such as cellulose acetate [3]. The modification might be carried out either as a separate preceding stage, or via adding MA into mixture directly during extrusion. Though, modern polymer technology is a searching of new substances for material properties improvement.

Dried quaternary ammonium salt, "Arquad 2HT-75" was proposed as a compatibilizer. New composite materials, based on LDPE, biocide-modified smectite-class clay (polyhexamethyleneguanidine modified montmorillonite, PHMG-MMT) and Arquad, with different concentration of compatibilizer were prepared. Its mechanical properties were studied, results are shown in table 1. The composite was more elastic, than that based on MA-modified LDPE. Structure of new composite films was examined by WAXD.

Table 1. Mechanical properties of composite materials compatibilized with dried "ARQUAD 2HT-75"

№	PHMG-MMT (5%); 0,2% Arquad	PHMG-MMT (5%); 0,5% Arquad	PHMG-MMT (5%); 1,5% Arquad	PHMG-MMT (5%); 3% Arquad	PHMG-MMT (5%); 5% Arquad
Thickness, mm	0,15 ± 0,02	0,12 ± 0,03	0,14 ± 0,03	0,15 ± 0,03	0,12 ± 0,02
Young modulus, MPa	81 ± 16	94 ± 34	95 ± 23	115 ± 33	116 ± 28
Yield stress, MPa	9,3 ± 0,95	7,8 ± 1,4	7,6 ± 0,8	8,1 ± 0,6	7,8 ± 1,0
Yield deformation %	85 ± 15	100 ± 70	55 ± 15	35 ± 15	90 ± 45
Strength, MPa	9,8 ± 1,8	8,5 ± 2,0	7,3 ± 1,1	7,7 ± 0,8	8,0 ± 1,1
Elongation at break, %	300 ± 170	220 ± 95	80 ± 15	110 ± 50	160 ± 60

Film samples containing 0,5% Arquad, were naturally aged in tropical environment in different exposure conditions (direct sunlight, outdoor and soil-shielded) for a half-year duration, then studied by FTIR, WAXD and tensile testing. Arquad-containing samples were less durable than their MA-containing counterparts, but retained most of the biocide — except direct sunlight exposure, where oxidative polyethylene destruction prevailed for all types of composites, irrelevant of compatibilizers, its' crystallinity had risen, and the biocide had decomposed fully.

## References

- [1] Manias et al., 2001. Chem. Mater. 13, 3516–3523.
- [2] Ganguly, A., Bhowmick, A.K., 2009. J. Mater. Sci. 44, 903–918.
- [3] Park et al., 2004. Macromolecules 37, 9076–9082.



# APPLICATION OF THE SPIN PROBE METHOD TO THE STUDY OF A LOW DENSITY POLYETHYLENE BLENDS WITH NATURAL RUBBER

*Varyan I.A.<sup>1,2</sup>, Karpova S.G.<sup>1</sup>, Kolesnikova N.N.<sup>1</sup>, Popov A.A.<sup>1,2</sup>*

<sup>1</sup>Emanuel Institute of Biochemical Physics, Russian Academy of Sciences, Moscow, Russia

<sup>2</sup>Plekhanov Russian University of Economics, Moscow, Russia

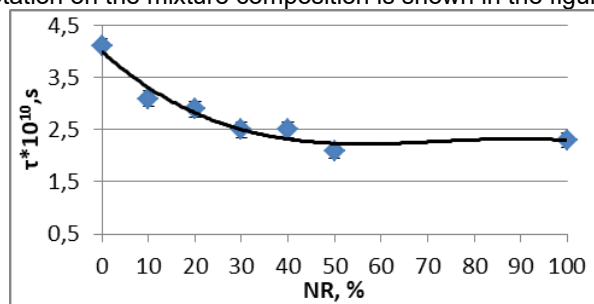
ivetta.varyan@yandex.ru

Considerable attention is currently being paid to the study of potentially biodegradable environmental compositions of synthetic polymers with natural additives. It was interesting to study the mixtures based on low density polyethylene (LDPE) as the most popular in the production of packaging and agricultural film materials with additives of natural rubber (NR), a product of plant origin that is easily biodegradable. The method of EPR spectroscopy of spin probes was used to study the molecular mobility in mixtures of PE with NR of different compositions.

Segmental mobility of macrochains was investigated using the stable nitroxyl radical of 2,2,6,6-tetra methylpiperidine-1-oxyl by EPR spectroscopy. A spin probe was introduced into films of vapors at a temperature of 40°C for the period of 1 hour. The EPR spectrums have the same characteristics typical for triplets. The values of the correlation time of probe rotation  $\tau$  were found from the EPR spectrums according to the formula:

$$\tau = \Delta H^+ \cdot [I^+/I^-]^{0.5} - 1] \cdot 6.65 \cdot 10^{-10},$$

where  $\Delta H^+$  is the width of the spectrum component located in a weak field;  $I^+ / I^-$  is the ratio of component intensities in weak and strong fields respectively. The measurement error  $\tau$  was  $\pm 5\%$ . The dependence of the correlation time  $\tau$  of probe rotation on the mixture composition is shown in the figure 1.



**Figure 1.** The dependence of the correlation time  $\tau$  of probe rotation on the mixture composition

The results of the study show that LDPE is characterized by a lower molecular mobility ( $4.1 \times 10^{-10}$  s) compared with NR ( $2.3 \times 10^{-10}$  s), which is associated with a higher rigidity of LDPE macromolecules. As for the compositions, there is a decrease of correlation time with the increase of rubber in comparison with both PE and the additive values of this parameter.

Partial combination of the mixture components leads to the formation of an interfacial layer with a reduced density compared to the densities of pure components [1]. Localization of the main part of the probes in rubber and in the interfacial layers leads to higher molecular mobility in the mixtures.

The materials under investigation were studied with the equipment of the common use centers at the Emanuel Institute of Biochemical Physics of the Russian Academy of Sciences and the Plekhanov Russian University of Economics.

## References

[1] V.N. Kuleznev. Polymer Blends and Alloys (Lecture Notes), Scientific Foundations and Technologies, Saint-Petersburg, 2013, 216 p.

# SYNTHESIS AND INVESTIGATION OF PH-SWITCHABLE RAFT AGENT IN POLYMERIZATION OF VINYL MONOMERS

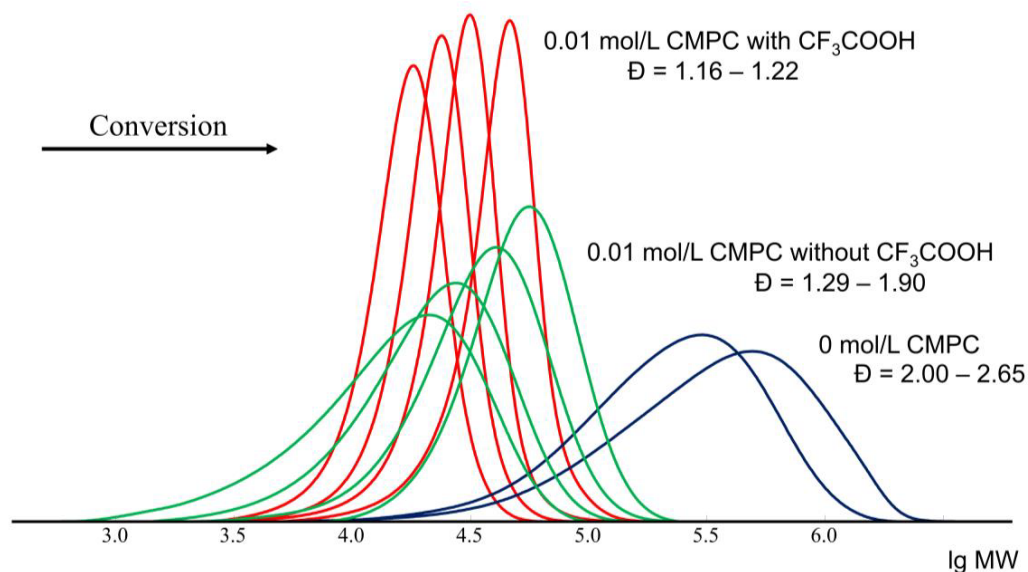
*Vlasov A.M.<sup>1</sup>, Grigoreva A.O.<sup>1</sup>, Zaitsev S.D.<sup>1</sup>*

<sup>1</sup>Lobachevsky State University of Nizhny Novgorod, Nizhny Novgorod, Russia  
Student  
eviliys5702@gmail.com

An urgent question of modern polymer science is how to synthesize polymer with certain physical, chemical, mechanical and other properties through macromolecular architecture and precise control of polymerization mechanism and polymer molar mass. For last 70 years there were made big steps in this area, in particular, were discovered and deeply investigated living ionic polymerization and living free-radical polymerization. These methods allow to synthesize polymers with significantly narrow molar mass distribution and wide range of different copolymers [1]. Among living free-radical polymerization methods, such as Stable Free-Radical Polymerization (SFRP), Atom Transfer Radical Polymerization (ATRP) and Reversible Addition-Fragmentation chain-Transfer (RAFT), which show good result in molecular characteristics control, the last one stands out for high tolerance to functional monomers and opens great opportunities for macromolecular architecture [2].

In recent years, new direction of researches has emerged in the context of RAFT polymerization. Considering the fact that, in general, more activated monomers (MAM) and less activated monomers (LAM) require agents with different structures to support chain transfer mechanism of reaction, there were attempts to synthesize more versatile RAFT agents, which can be used in polymerization of both types of monomers and their copolymerization. pH-switchable RAFT agents can exist in neutral and protonated forms and show different activity in MAMs and LAMs polymerization [3].

pH-switchable RAFT agent 1-cyano-1-methylethyl (phenyl)(pyridin-4-yl)-carbamodithioate (CMPC) was synthesized and reversible addition-fragmentation chain-transfer (RAFT) polymerization of styrene, vinyl acetate and methyl methacrylate was carried out. It was shown that presence of CMPC affects molar mass distribution and kinetic features and realizes supposed mechanism of RAFT polymerization. Different effect of CMPC on polymerization in presence of protic acids was investigated.



**Figure 1.** SEC curves normalized by the unit area for polymerization of styrene in presence of CMPC

## References

- [1] Chernikova E. V., Sivtsov E. V. *Polymer Science, Series B* **2017**, 59, 117–146.
- [2] Barner-Kowollik C., *Handbook of RAFT Polymerization*, WILEY-VCH, Weinheim, **2008**.
- [3] Keddie D. J., Guerrero-Sanchez C., Moad G., Mulder R. J., Rizzardo E., Thang S. H. *Macromolecules* **2012**, 45, 4205-4215.

Acknowledgements. This work was supported by the Russian Foundation for Basic Research (Project № 19-03-00843).

# APPLICATION OF ADDITIVE 3D PRINTING TECHNOLOGY IN THE FORMATION OF COMPOSITE CHITOSAN-CONTAINING HYDROGEL SCAFFOLDS FOR TISSUE ENGINEERING

*Zakharova V.A.<sup>1</sup>, Kildeeva N.R.<sup>1</sup>, Gordeev V.V.<sup>2</sup>*

<sup>1</sup>A.N.Kosygin Russian State University, Moscow, Russia

<sup>2</sup>PharmPrint, Moscow, Russia

phD student

[vasilinaqss@gmail.com](mailto:vasilinaqss@gmail.com)<sup>1</sup>, [ceo@pharmprinter.com](http://ceo@pharmprinter.com)<sup>2</sup>

The development of biomimetic scaffolds for the targeted restoration of damaged or lost tissues and organs, using cell technologies and new biomaterials, is a key area in tissue engineering [1]. Recently, the additive technology of 3D printing has attracted considerable interest for the creation of tissue-engineered structures due to the ability to form three-dimensional complex structures of almost any shape from a digital model, with high speed and resolution [2].

Today, an urgent problem is the design of a manipulative individual high-performance printing installation and the creation of hydrogel inks based on environmentally friendly biopolymers of natural origin, intended for 3D printing technologies. Particular attention is paid to the development of chitosan-containing composite hydrogel printing inks. The prospect of using chitosan is due to its unique physical, chemical, and biological properties, the absence of toxic effects on a living organism. Composite hydrogels based on it provide the structural integrity of the formed structures, control the delivery of drugs and enzymes, and maintain the adhesion and functional activity of cell cultures [3].

The aim of this work is to obtain biodegradable polymer 3D-printed frameworks with a programmable shape and controlled surface structure, based on composite materials with flexible and organized meshes, based on chitosan and its compositions with other polymers, with pronounced biological properties and anti-inflammatory activity.

Together with PharmPrint, a custom manipulative injection 3D printer design was developed for printing with hydrogel materials with adjustable speed and resolution. The main directions and conditions for obtaining chitosan-containing printed hydrogel ink are determined. It has been established that the methods and conditions for the formation of scaffolds based on composite chitosan-containing materials determine the matrix structure, thickness and orientation of molecular layers, surface morphology, and other parameters affecting the expansion of the possibilities of its use as an object of tissue engineering [4].

## References

- [1] Ambekar R.S., Kandasubramanian B. *Ind. Eng. Chem. Res.* **2019**, 58 (16), 6163–6194.
- [2] Hassan M., Dave K., Chandrawati R., Dehghani F., Gomes V.G. *European Polymer Journal* **2019**, 121, 109340.
- [3] Zakharova V.A., Kildeeva N.R. *Polysaccharides* **2021**, 2 (1), 154–167.
- [4] Vasilenko I., Kil'deeva N., Metelin V., Sazhnev N., Zakharova V., Shikhina N. *Proc. SPIE* 11076, 110761R, **2019**.

Acknowledgements. This work was supported the Russian Science Foundation (grant № 18-29-17059).

ORGANOPHOSPHATE POLYURETHANE MEMBRANES  
WITH THERMOSENSITIVE VAPOR PERMEABILITY

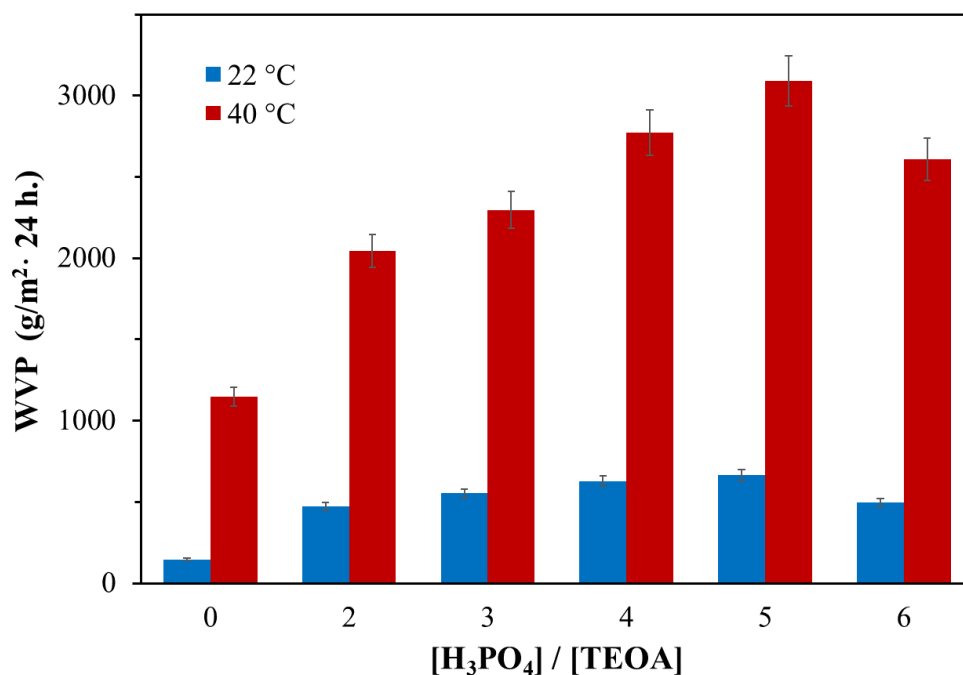
*Zakirov I.N., Sazonov O.O., Faizulina Z.Z., Saifieva A.R., Melnikov N.A., Davletbaeva I.M.*

Kazan national research technological university, Kazan, Russia  
Postgraduate student, profile «Technology and processing of polymers and composites»  
zakirovilyas1996@gmail.com

Polyurethane membranes with thermosensitive vapor permeability are multifunctional materials that have the ability to change their diffusion properties depending on the ambient temperature. This type of material is widely used as: packaging for food products, a vapor-permeable layer in clothes, a selective layer in the processes of separation of liquids and gases [1-3].

In works [4], amino ethers of *ortho*-phosphoric acid (AEPA) based on triethanolamine (TEOA),  $H_3PO_4$  and polyoxyethylene glycol (MW=400) were synthesized and investigated. The ionomeric nature of polyurethanes obtained based on AEPA (AEPA-PU) was the reason for their study as vapor-permeable membrane materials.

Polyurethane thin-film materials were obtained based on AEPA and an aromatic polyisocyanate from the melt of the urethane-forming system, without the use of solvents. It was found that the obtained polyurethanes have a thermosensitive vapor permeability, and the vapor permeability coefficient is significantly influenced by the content of ionogenic groups in the composition of AEPA-PU (Fig.)



**Figure.** Water vapor permeability coefficients for AEPA-PU, obtained at solute content = 100 wt.% on molar ratio  $[H_3PO_4]/[TEOA]$

#### References

- [1] Turan D. Food Eng. Rev. **2019**
- [2] Lomax G.R. J. Mat. Chem. **2007**, 17, 2775-2784
- [3] Hu M. J. Chem. Technol. Biotechnol. **2015**, 90, 2195–2207
- [4] Davletbaeva I.M. MDPI Polymers **2021**, 13, 1442

Acknowledgements. This work was supported by Russian Foundation for Basic Research (project No 19-19-00136).

NOVEL ULTRAFILTRATION MEMBRANES BASED ON POLYACRYLONITRILE  
MODIFIED BY TITANIUM DIOXIDE

*Zolotarev A.A.<sup>1</sup>, Kuzminova A.I.<sup>1</sup>, Plisko T.V.<sup>2</sup>, Penkova A.V.<sup>1</sup>*

<sup>1</sup>Saint Petersburg State University, Saint Petersburg, Russia

<sup>2</sup>Institute of Physical Organic Chemistry, National Academy of Sciences of Belarus, Minsk, Belarus

Researcher

andrey.zolotarev@spbu.ru

Polyacrylonitrile (PAN) is one of the most commonly used polymers for ultrafiltration (UF) membranes. Advantages of PAN include stability in non-polar and low-polar organic solvents, such as hydrocarbons, alcohols, esters, relatively high chemical and thermal stability, in particular, resistance to active chlorine, and low cost. UF membranes from PAN have found industrial application in biotechnology, medicine, textile industry, wastewater treatment. One of the main problems for PAN membranes is fouling in the filtration process and its loss of performance. To prevent contamination of ultrafiltration membranes, PAN-based photocatalytic membranes modified with titanium oxide have been developed.

Titanium dioxide (TiO<sub>2</sub>) is the most commonly used semiconductor for photocatalytic membranes, due to its chemical and thermal stability, low cost, high reusability, and excellent yield in the degradation of organic pollutants. In the present work the novel membranes based on polyacrylonitrile (PAN) modified by titanium dioxide TiO<sub>2</sub>. The improvement of the transport properties of polymer membranes occurs due to the properties of TiO<sub>2</sub>. Several types of modification of ultrafiltration membranes have been developed: (1) the solid-phase method of modification of the polymer with nano-sized and micro-sized TiO<sub>2</sub>, (2) the solution method of modification of the polymer with TiO<sub>2</sub>, (3) dynamic deposition of micro-sized TiO<sub>2</sub>. The developed PAN/TiO<sub>2</sub> membranes were studied using scanning electron microscopy, atomic force microscopy, contact angle and porosity. The transport properties of the developed membranes were studied by ultrafiltration separation of the bovine serum albumin (BSA) and cutting fluid. The introduction of TiO<sub>2</sub> into the polymer matrix leads to significant changes in properties of membranes based on polyacrylonitrile (PAN).

**Acknowledgements.** The reported study was funded by RFBR, Sirius University of Science and Technology, JSC Russian Railways and Educational Fund "Talent and success", project number 20-38-51022. The experimental work of this study was facilitated by the equipment from the Resource Centre of Geomodel, Chemical Analysis and Materials Research Centre, Centre for X-ray Diffraction Methods, Magnetic Resonance Research Centre, Centre for Innovative Technologies of Composite Nanomaterials, Nanophotonics Centre, Cryogenic department, Thermogravimetric and Calorimetric Research Centre and the Interdisciplinary Resource Centre for Nanotechnology at the St. Petersburg State University.

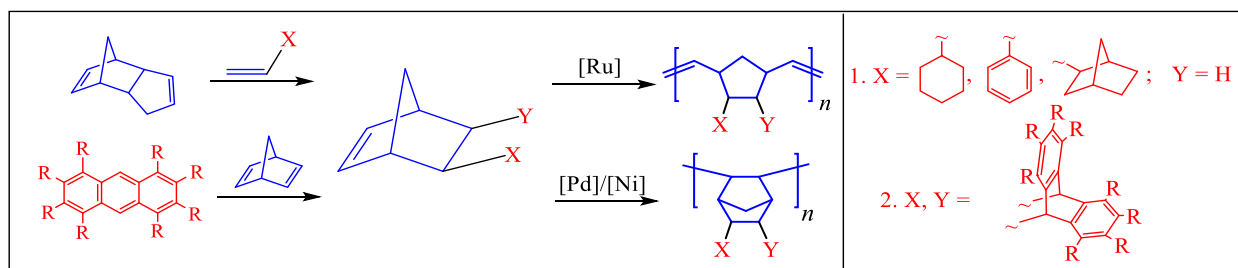
## POLYNORBORNENES WITH CARBOCYCLIC SUBSTITUENTS

Zotkin M.A., Alentiev D.A., Bermesheva E.V., Borisov I.L., Volkov A.V., Finkelstein E. Sh., Bermeshev M.V.

A.V. Topchiev Institute of Petrochemical Synthesis, Moscow, Russia  
 PhD Student  
[zotkin@ips.ac.ru](mailto:zotkin@ips.ac.ru)

Norbornenes are unique monomers for the preparation of polymers for different purposes. Facile synthesis of norbornenes with various substituents, along with their ability to be polymerized via various mechanisms, make norbornene-based polymers convenient objects for studying important structure-property relationships [1]. The introduction of bulky and rigid substituents into the side chain of polynorbornenes increases the free volume and, as a consequence, leads to an increase in porosity and gas permeability. It was previously shown that addition polynorbornenes containing rigid and bulky trimethylsilyl groups in the side chains are characterized by high gas permeability [1]. For other classes of polymers (in particular, polyacetylenes [2]), it was found that the introduction of carbocyclic substituents also leads to an increase in porosity and gas permeability. However, polynorbornenes containing carbocyclic side chain substituents have not yet been fully studied.

In our work, the synthesis of cycloalkyl-substituted norbornenes was carried out through one stage by Diels-Alder reaction, using commercially available or easy-to-synthesize compounds: dicyclopentadiene, norbornadiene, vinylcyclohexane, anthracene-derivatives, etc. Then the resulting monomers were involved into metathesis and addition polymerization (Fig. 1).



**Figure 1.** Synthesis and polymerization of cycloalkyl-substituted norbornenes.

Since the highest pore characteristics and gas permeability are found for addition polynorbornenes (due to the formation of a more rigid structure), their preparation and investigation are of the highest priority for us. Considering that addition polymerization is more sensitive to the presence and the nature of substituents as compared to metathesis polymerization, the presence of bulky carbocyclic substituents significantly complicates the search for effective catalysts. In most cases, the addition polymerization proceeded successfully in the presence of the classical catalytic system based on palladium ( $\text{Pd}(\text{OAc})_2/\text{NaBARF}/\text{PCy}_3$ ); some monomers were polymerized to form soluble polymers only using the nickel complex  $(\text{PhMe})\text{Ni}(\text{C}_6\text{F}_5)_2$ . Catalytic systems based on N-heterocyclic carbene Pd-complexes, for example,  $\text{SiMesPd}(\text{cinn})\text{Cl}$ , exhibited very high polymerization activity and tolerance to the presence of cycloalkyl substituents. The study of the gas transport properties of the obtained polynorbornenes showed that the introduction of carbocycles into the side chain led to an increase in gas permeability of a polymer. The study of polymers by low-temperature nitrogen adsorption-desorption demonstrated that the introduced substituents contributed to the formation of a microporous structure with a large specific surface area.

### References

[1] Finkelshtein E.S., Bermeshev M.V., Gringolts M.L., Starannikova L.E., Yampolskii Yu.P. *Russ. Chem. Rev.* **2011**, *80*, 341–361.

[2] Hu Y., Shiotsuki M. et al. *Macromolecules*. **2008**. – Vol. 41 (22). P. 8525-8532.

Acknowledgements. This work was supported by the Russian Foundation for Basic Research (project No 21-73-20246).

VVM PUBLISHING LLC  
Order 1537  
St. Petersburg, Shvetsova str., 41